

**FineAdjust  
Applicator**

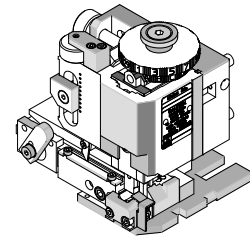

**Application Tooling  
Specification Sheet**



**Order No. 63860-5100**

**FEATURES**

- Quick punch removal with the push of a button for fast and easy tooling change
- Applicator designed to industry standard mounting and shut height 135.80mm (5.346")
- Quick set-up time; plus the crimp height, track and feed adjustments can be set without removing the applicator from the press
- Fine adjustment allows users to achieve target with little effort by adjusting in increments of .015mm (.0006") for conductor crimp height and .063mm (.0025") for insulation height
- Independent adjustment rings allow users to quickly adjust the conductor or insulation crimp height without affecting each other
- Directly adapts to most automatic wire processing machines

**SCOPE**

Products: 2.50mm (.098") Pitch Crimp Terminals, 22-28 AWG.

Terminal Series No.	Terminal Order No.		Wire Size		Insulation Diameter				Strip Length	
					IPC/WHMA-A60 (1)		Terminal (2)			
					AWG	mm <sup>2</sup>	mm	In.		
35074	35074-8001	35074-9002	22-28	0.35-0.08	1.20-1.65	.047-.065	1.15-1.80	(.045-.071)	2.30-2.80	.091-.110
50351	50351-8000		22-28	0.35-0.08	1.20-1.65	.047-.065	1.15-1.80	(.045-.071)	2.30-2.80	.091-.110
57915	57915-8001	57915-9002	22-28	0.35-0.08	1.20-1.65	.047-.065	1.15-1.80	(.045-.071)	2.30-2.80	.091-.110

(1) To achieve optimum IPC-A620 Class 2 insulation crimps, use this insulation OD.  
 (2) Overall insulation OD specification for terminal.

**DEFINITION OF TERMS**

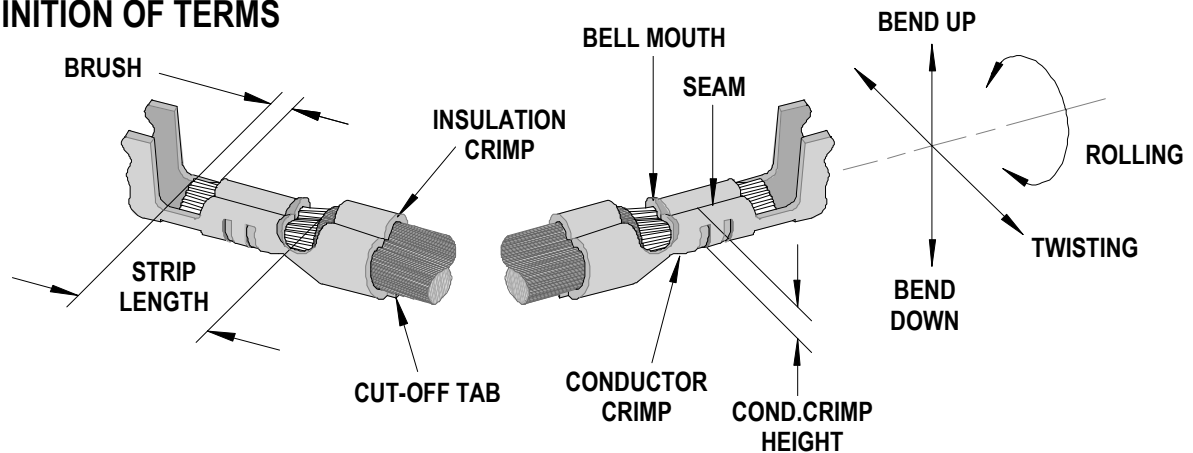

The above terminal drawing is a generic terminal representation. It is not an image of any terminal listed in the scope.

## CRIMP SPECIFICATION

Terminal Series No.	Bell mouth		Cut-off Tab Maximum		Conductor Brush	
	mm	In.	mm	In.	mm	In.
35074	0.05-0.40	.002-.016	0.20	.008	0.00-0.80	.000-.032
50351	0.05-0.40	.002-.016	0.20	.008	0.00-0.80	.000-.032
57915	0.05-0.40	.002-.016	0.20	.008	0.00-0.80	.000-.032

Terminal Series No.	Bend up	Bend down	Twist	Roll	Punch Width (Ref)				Seam Seam shall not be open and no wire allowed out of the crimping area
					Conductor		Insulation		
	Degree		Degree		mm	In	mm	In	
35074	3	3	3	6	1.20	.047	1.80	.071	
50351	3	3	3	6	1.20	.047	1.80	.071	
57915	3	3	3	6	1.20	.047	1.80	.071	

After crimping, the crimp profiles should measure the following:

Terminal Series No.	Wire Size		Conductor				Insulation				Pull Force Minimum	
			Crimp Height		Crimp Width (Ref)		Crimp Height (Ref)		Crimp Width (Ref)			
	AWG	mm <sup>2</sup>	mm	In.	mm	In.	mm	In.	mm	In.	N	Lb.
35074	22	0.35	0.84-0.89	.033-.035	1.20	.047	1.70	.067	1.80	.071	39.2	8.8
	24	0.20	0.76-0.81	.030-.032	1.20	.047	1.70	.067	1.80	.071	29.4	6.6
	26	0.12	0.71-0.76	.028-.030	1.20	.047	1.70	.067	1.80	.071	19.6	4.4
	28	0.08	0.67-0.72	.026-.028	1.20	.047	1.70	.067	1.80	.071	9.8	2.2
50351	22	0.35	0.84-0.89	.033-.035	1.20	.047	1.70	.067	1.80	.071	39.2	8.8
	24	0.20	0.76-0.81	.030-.032	1.20	.047	1.70	.067	1.80	.071	29.4	6.6
	26	0.12	0.71-0.76	.028-.030	1.20	.047	1.70	.067	1.80	.071	19.6	4.4
	28	0.08	0.67-0.72	.026-.028	1.20	.047	1.70	.067	1.80	.071	9.8	2.2
57915	22	0.35	0.84-0.89	.033-.035	1.20	.047	1.70	.067	1.80	.071	39.2	8.8
	24	0.20	0.76-0.81	.030-.032	1.20	.047	1.70	.067	1.80	.071	29.4	6.6
	26	0.12	0.71-0.76	.028-.030	1.20	.047	1.70	.067	1.80	.071	19.6	4.4
	28	0.08	0.67-0.72	.026-.028	1.20	.047	1.70	.067	1.80	.071	9.8	2.2

**T** Tool Qualification Notes:

1. Pull Force should be measured with no influence from the insulation crimp.
2. The above specifications are guidelines to an optimum crimp.

## PARTS LIST

FineAdjust Applicator 63860-5100				
Item	Order No	Engineering No.	Description	Quantity
<b>Perishable Tooling</b>				
	63860-5170	63860-5170	Tool Kit (All "Y" Items)	REF
1	63444-1210	63444-1210	Conductor Punch	1 Y
2	63445-1220	63445-1220	Conductor Anvil	1 Y
3	63446-1816	63446-1816	Insulation Punch	1 Y
4	63445-1819	63445-1819	Insulation Anvil	1 Y
5	63443-0002	63443-0002	Cut-Off Plunger Front	1 Y
6	63443-0012	63443-0012	Plunger Retainer Front	1 Y
<b>Other Components</b>				
7	11-18-4083	60707-8	Feed Guide	1
8	11-24-1067	4996-4	Cut-Off Plunger Spring	1
9	11-40-4039	8302-5	Plunger Striker	1
10	63443-0009	63443-0009	Front Scrap Chute	1
11	63443-0021	63443-0021	Key	1
12	63443-2405	63443-2405	Anvil Mount	1
13	63443-4005	63443-4005	Wire Stop	1
14	63443-6003	63443-6003	Rear Cover	1
<b>Frame</b>				
15	63800-4901	63800-4901	Top	1
16	63801-3281	63801-3281	Base	1
17	63801-4650	63801-4650	Track	1
<b>Hardware</b>				
18	N/A	N/A	M3 by 6 Long SHCS	2**
19	N/A	N/A	M4 by 6 Long SHCS	1**
20	N/A	N/A	M4 by 10 Long BHCS	2**
21	N/A	N/A	M4 by 16 Long BHCS	1**
22	N/A	N/A	M4 by 20 Long SHCS	1**
23	N/A	N/A	M4 by 50 Long SHCS	2**
24	N/A	N/A	3mm by 6 Long Roll Pin	1**
25	N/A	N/A	#10-32 by 1/4" Long BHCS	1**
** Available from an industrial supply company such as MSC (1-800-645-7270).				

### Assembly Drawing

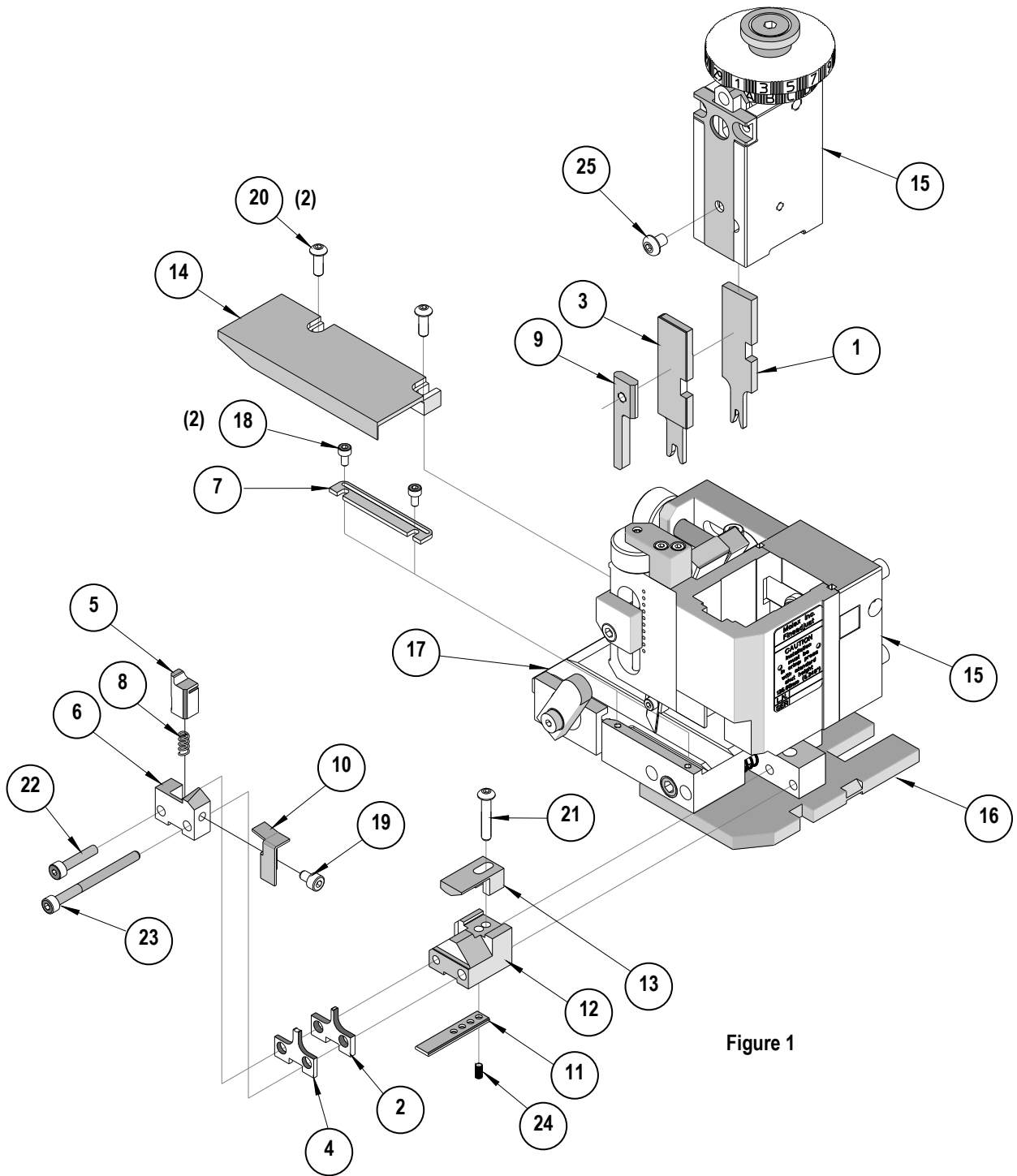

## NOTES

1. Molex recommends an extra perishable tooling kit be maintained at your facility.
2. Verify tooling alignment by manually cycling the press and Applicator before crimping under power. Check that all screws are tight.
3. Slugs, Terminals, Dirt and Oil should be kept clear of work area.
4. Wear safety glasses at all times.
5. For recommended maintenance refer to the FineAdjust Manual.

**CAUTION:** This applicator should only be used in a press with a shut height of 135.80 mm (5.346"). Tooling damage could result at a lower setting.

**CAUTION:** To prevent injury never operate this Applicator without the guards supplied with the press or wire-processing machine in place. Reference the press or wire processing manufacturer's instruction manual.

**CAUTION:** Molex crimp specifications are valid only when used with Molex terminals, applicators and tooling.

<http://www.molex.com>



Компания «ЭлектроПласт» предлагает заключение долгосрочных отношений при поставках импортных электронных компонентов на взаимовыгодных условиях!

Наши преимущества:

- Оперативные поставки широкого спектра электронных компонентов отечественного и импортного производства напрямую от производителей и с крупнейших мировых складов;
- Поставка более 17-ти миллионов наименований электронных компонентов;
- Поставка сложных, дефицитных, либо снятых с производства позиций;
- Оперативные сроки поставки под заказ (от 5 рабочих дней);
- Экспресс доставка в любую точку России;
- Техническая поддержка проекта, помощь в подборе аналогов, поставка прототипов;
- Система менеджмента качества сертифицирована по Международному стандарту ISO 9001;
- Лицензия ФСБ на осуществление работ с использованием сведений, составляющих государственную тайну;
- Поставка специализированных компонентов (Xilinx, Altera, Analog Devices, Intersil, Interpoint, Microsemi, Aeroflex, Peregrine, Syfer, Eurofarad, Texas Instrument, Miteq, Cobham, E2V, MA-COM, Hittite, Mini-Circuits, General Dynamics и др.);

Помимо этого, одним из направлений компании «ЭлектроПласт» является направление «Источники питания». Мы предлагаем Вам помощь Конструкторского отдела:

- Подбор оптимального решения, техническое обоснование при выборе компонента;
- Подбор аналогов;
- Консультации по применению компонента;
- Поставка образцов и прототипов;
- Техническая поддержка проекта;
- Защита от снятия компонента с производства.



#### Как с нами связаться

**Телефон:** 8 (812) 309 58 32 (многоканальный)

**Факс:** 8 (812) 320-02-42

**Электронная почта:** [org@eplast1.ru](mailto:org@eplast1.ru)

**Адрес:** 198099, г. Санкт-Петербург, ул. Калинина, дом 2, корпус 4, литера А.