



Features

- Multi-stage protection
- Balanced TRIGARD®
- Quick response to surges
- High energy handling
- Reliability is improved by elimination of the air Back-Up-Gap (BUG)
- Meets test requirements of Telcordia GR 974, GR1361, SR 5165 and RUS PE-80
- Telcordia Analysis report DA-1843
- High-speed network compatible
- Binding post or optional Insulation Displacement Connectors (IDC)
-  UL Listed per UL 497 (File: E53117)

2377-45 Series Digi.Guard – MSP® Maximum Duty Station Protector

Bourns® Model 455HS Multi-Stage Protector (MSP®) is a new generation telecommunications station protector designed to be the best all around choice for protecting copper pair voice-band and high-speed data circuits. Combining the strengths of Gas Discharge Tube (GDT) and solid state overvoltage protection, the Model 455HS MSP® integrates three advanced technologies: our proprietary advanced GDT, precision matched metal oxide varistors (MOV), and a patented Switch-Grade Fail-Short mechanism. The 2377 series offer superior service life, far exceeding Telcordia standards.

Bourns® 2377-45 can be used universally for POTS and high speed data, e.g. ISDN, ADSL, ADSL2+, VDSL, VDSL2, other xDSL protocols and high speed Ethernet. Bourns® MSP® technology provides unparalleled overvoltage protection with low loss on paired copper communications circuits. The Model 455 is the most economical, reliable and effective choice to protect paired copper communications circuits. The IDC version, with environmental sealant, provides additional ease of installation and protection against corrosion.

Characteristics

Tested per IEEE C62.31, UL 497, CSA C22.2, Telcordia GR-1361 and applicable sections of Telcordia GR 974.

DC Breakdown	300-400 V
AC Breakdown	60 Hz 300-400 V
Impulse Breakdown.....	100 V/μs 600 V
	1000 V/μs 650 V
Insulation Resistance	100 Vdc > 1 GΩ
Insertion Loss	100 MHz < 0.4 dB (Category 5)
Return Loss	100 MHz > 14 dB (Category 5)
Capacitance Line to Line - Binding Post.....	1 MHz..... 12 pF typical
Capacitance Line to Line - IDC	1 MHz 14 pF typical
Capacitance Line to Ground - Binding Post	1 MHz 24 pF typical
Capacitance Line to Ground - IDC.....	1 MHz..... 28 pF typical
Impulse Reset ¹	52 V, 260 mA < 10 ms ³
	135 V, 200 mA < 10 ms ³
	150 V, 200 mA < 150 ms
Impulse Life Characteristics (Per-Side, Simultaneously)	100 A, 10/1000 μs > 3000 operations ²
	300 A, 10/1000 μs > 1000 operations ²
	500 A, 10/1000 μs > 1000 operations ⁴
	2,000 A, 10/250 μs > 100 operations ²
	5,000 A, 20/100 μs > 10 operations ²
	20,000 A, 8/20 μs > 10 operations ⁴
AC Life Characteristics.....	0.5 A rms continuous > 30 seconds
	1 A rms, 1 second, 600 ft. cable > 60 operations
	1 A rms, 1 second, 1 mile cable..... > 60 operations
	10 A rms, 1 second > 20 operations
	200 A rms, 11 cycles..... 1 operation ⁵
	120 A rms, 0.1 second 1 operation
Life Test Criteria	
Insulation Resistance Throughout the Life Test	100 MΩ
Life Test Failures.....	0.0 %
Failures During Environmental Cycling w/ surges	0.0 %
Fail-Short (vented or non-vented gas tube)	> 30 Arms, simultaneously
Operating Temperature	-55 to +85 °C

Notes:

¹ Network Applied

² Exceeds Telcordia (Bellcore) GR 1361

³ Surpasses Telcordia GR 974

⁴ RUS (REA) PE-80

⁵ Protector may short to ground

Line to Line voltage is approximately 1.8 to 2 times the stated Line to Ground breakdown voltage.

Specifications are subject to change without notice.

The device characteristics and parameters in this data sheet can and do vary in different applications and actual device performance may vary over time. Users should verify actual device performance in their specific applications.

2377-45 Series Digi.Guard – MSP® Maximum Duty Station Protector

BOURNS®

Product Dimensions

2377-45-HS, 2377-45-BC

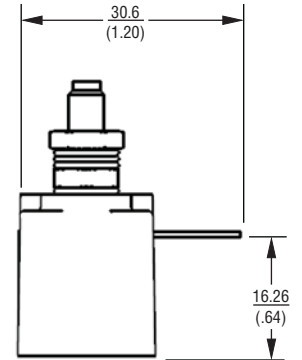
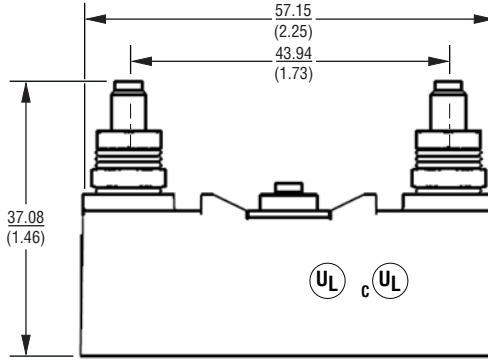
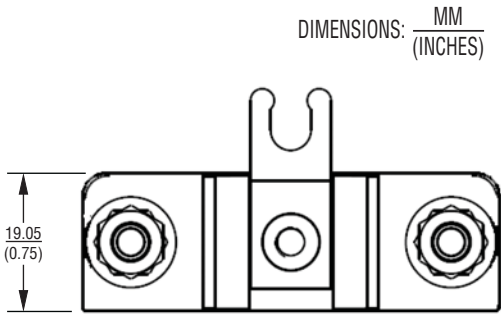

2377-45-HS-IDC, 2377-45-BC-IDC

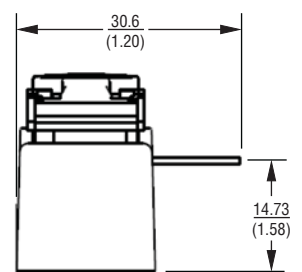
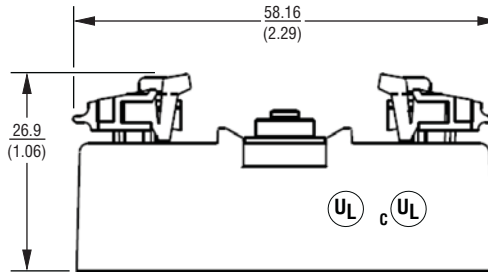
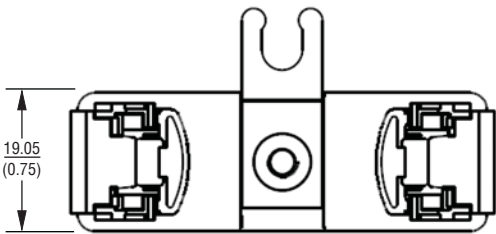

2372-02 Ground Mounting Stud (order separately)

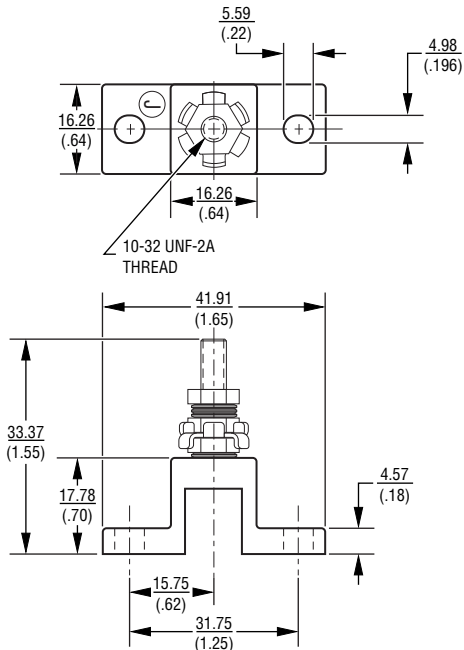

How To Order

- 2377-45-HS Binding Post Connectors
- 2377-45-BC* Balanced Capacitance, Binding Post Connectors
- 2377-45-HS-IDC Insulation Displacement Connectors
- 2377-45-BC-IDC* Balanced Capacitance, Insulation Displacement Connectors

* BC versions for xDSL systems that require Tip-to-Ground and Ring-to-Ground capacitive balance of ≤ 1 pF.

Related Products

-  80052 Test Clip for IDC
-  80053 Insulation Tool for IDC

REV. N 03/15

Specifications are subject to change without notice. The device characteristics and parameters in this data sheet can and do vary in different applications and actual device performance may vary over time. Users should verify actual device performance in their specific applications.



Компания «ЭлектроПласт» предлагает заключение долгосрочных отношений при поставках импортных электронных компонентов на взаимовыгодных условиях!

Наши преимущества:

- Оперативные поставки широкого спектра электронных компонентов отечественного и импортного производства напрямую от производителей и с крупнейших мировых складов;
- Поставка более 17-ти миллионов наименований электронных компонентов;
- Поставка сложных, дефицитных, либо снятых с производства позиций;
- Оперативные сроки поставки под заказ (от 5 рабочих дней);
- Экспресс доставка в любую точку России;
- Техническая поддержка проекта, помощь в подборе аналогов, поставка прототипов;
- Система менеджмента качества сертифицирована по Международному стандарту ISO 9001;
- Лицензия ФСБ на осуществление работ с использованием сведений, составляющих государственную тайну;
- Поставка специализированных компонентов (Xilinx, Altera, Analog Devices, Intersil, Interpoint, Microsemi, Aeroflex, Peregrine, Syfer, Eurofarad, Texas Instrument, Miteq, Cobham, E2V, MA-COM, Hittite, Mini-Circuits, General Dynamics и др.);

Помимо этого, одним из направлений компании «ЭлектроПласт» является направление «Источники питания». Мы предлагаем Вам помощь Конструкторского отдела:

- Подбор оптимального решения, техническое обоснование при выборе компонента;
- Подбор аналогов;
- Консультации по применению компонента;
- Поставка образцов и прототипов;
- Техническая поддержка проекта;
- Защита от снятия компонента с производства.



Как с нами связаться

Телефон: 8 (812) 309 58 32 (многоканальный)

Факс: 8 (812) 320-02-42

Электронная почта: org@eplast1.ru

Адрес: 198099, г. Санкт-Петербург, ул. Калинина, дом 2, корпус 4, литера А.