

PLEASE CHECK WWW.MOLEX.COM FOR LATEST PART INFORMATION

Part Number: [5024262230](#)
Status: **Active**
Overview: [SlimStack™](#)
Description: 0.40mm (.016") Pitch SlimStack™ Board-to-Board Receptacle, SMT, Dual Row, Vertical, 1.00mm (.039") Stacking Height, With Solder Tabs, with Vacuum Tape, 22 Circuits

Documents:

[3D Model](#) [Product Specification PS-502426-001 \(PDF\)](#)
[Drawing \(PDF\)](#) [RoHS Certificate of Compliance \(PDF\)](#)

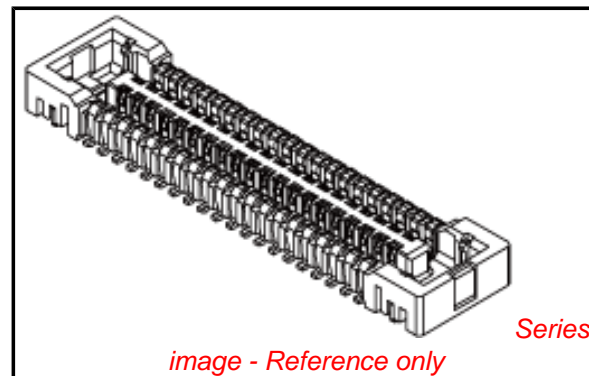

General

Product Family	PCB Receptacles
Series	502426
Application	Board-to-Board
Overview	SlimStack&#153
Product Name	SlimStack™

Physical

Circuits (Loaded)	22
Color - Resin	Black
Durability (mating cycles max)	30
Glow-Wire Compliant	No
Lock to Mating Part	Yes
Mated Height (in)	0.039 In
Mated Height (mm)	1.00 mm
Material - Metal	Phosphor Bronze
Material - Plating Mating	Gold
Material - Plating Termination	Gold
Number of Rows	2
Orientation	Vertical
PCB Locator	No
PCB Retention	Yes
Packaging Type	Embossed Tape on Reel
Pitch - Mating Interface (in)	0.016 In
Pitch - Mating Interface (mm)	0.40 mm
Polarized to Mating Part	No
Polarized to PCB	No
Stackable	No
Temperature Range - Operating	-25°C to +85°C
Termination Interface: Style	Surface Mount

Electrical

Current - Maximum per Contact	0.3A
Voltage - Maximum	50V AC/DC

Material Info

Reference - Drawing Numbers

Application Specification	AS-502426-001
Product Specification	PS-502426-001, RPS-502426-011, RPS-502426-013, RPS-502426-014, RPS-502426-015, RPS-502426-017, RPS-502426-019
Sales Drawing	SD-502426-003, SD-502426-004

EU RoHS

ELV and RoHS Compliant

REACH SVHC

Not Reviewed

Halogen-Free

Status

Not Reviewed

Need more information on product environmental compliance?

Email productcompliance@molex.com
 For a multiple part number RoHS Certificate of Compliance, [click here](#)

Please visit the [Contact Us](#) section for any non-product compliance questions.

China RoHS



Search Parts in this Series

[502426Series](#)

Mates With

[502430 PCB Header](#)

This document was generated on 05/18/2010

PLEASE CHECK WWW.MOLEX.COM FOR LATEST PART INFORMATION

10 9 8 7 6 5 4 3 2 1

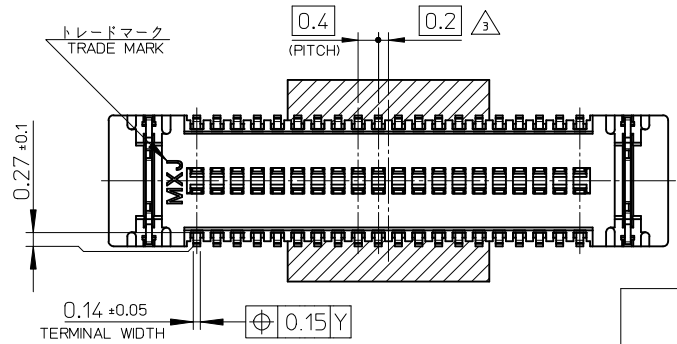
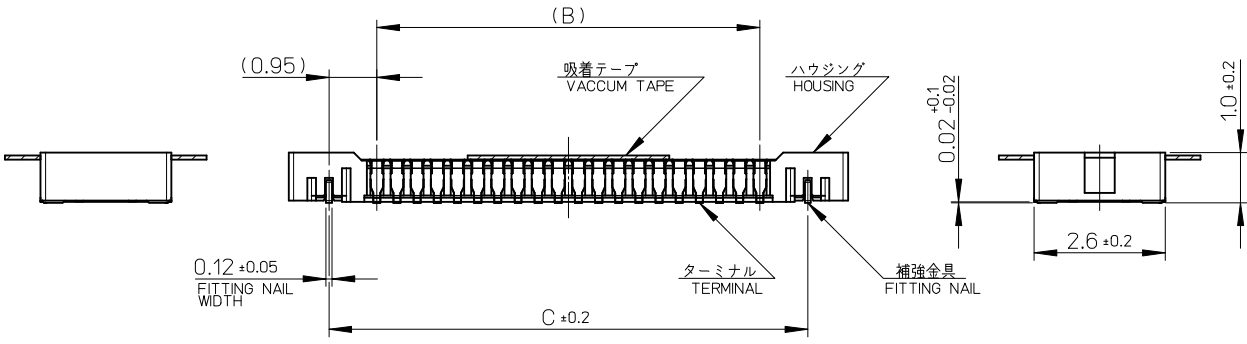
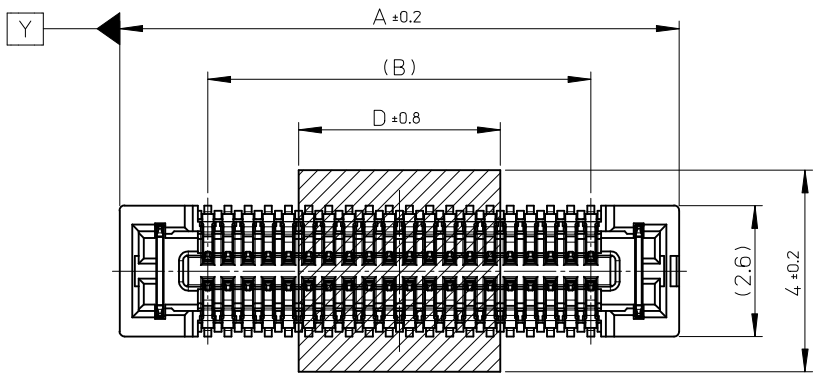

10.0	19.5	17.6	21.1	502426-9030	90
	17.5	15.6	19.1	502426-8030	80
	15.5	13.6	17.1	502426-7030	70
7.0	13.5	11.6	15.1	502426-6030	60
	11.5	9.6	13.1	502426-5030	50
4.0	9.5	7.6	11.1	502426-4030	40
	7.9	6.0	9.5	502426-3230	32
3.4	6.7	4.8	8.3	502426-2630	26
	6.3	4.4	7.9	502426-2430	24
	5.9	4.0	7.5	502426-2230	22
2.4	5.5	3.6	7.1	502426-2030	20
D	4.3	2.4	5.9	502426-1430	14
				EMBOSSED TAPE PACKAGE	CKT.
				ORDER No.	

CONNECTOR SERIES No. : 502426-**39

REVISED EC NO: J2009-0889 DRWN: YA0YAGI 2009/06/15 CHKD: THARUYAMA 2009/06/15 APPR: NUKITA 2009/06/15	GENERAL TOLERANCES (UNLESS SPECIFIED)		DIMENSION STYLE MM ONLY		SCALE 10:1	DESIGN UNITS METRIC	THIRD ANGLE PROJECTION		
	10 UNDER ± ---	10 OVER 30 UNDER ± ---	30 OVER ± ---	DRAWN BY RTAKEUCHI	DATE 2007/12/26	TITLE 0.4 B-TO-B CONN. HGT=1.0 W=2.6 REC ASSY WITH TAPE			
	ANGULAR ± --- °			CHECKED BY MSASAO	DATE 2007/12/26	MOLEX INCORPORATED			
	DRAFT WHERE APPLICABLE MUST REMAIN WITHIN DIMENSIONS			APPROVED BY MSASAO	DATE 2007/12/26	MATERIAL NO. SEE TABLE	DOCUMENT NO. SD-502426-003	SHEET NO. 1 OF 2	
				SIZE A3	THIS DRAWING CONTAINS INFORMATION THAT IS PROPRIETARY TO MOLEX INCORPORATED AND SHOULD NOT BE USED WITHOUT WRITTEN PERMISSION				

注記 NOTES

1. 使用材料 MATERIAL

ハウジング：液晶ポリマー（LCP） ガラス充填 UL94V-0（黒）
 HOUSING: LIQUID CRYSTAL POLYMER (GLASS FILLED) UL94V-0 (COLOR: BLACK)
 ターミナル：りん青銅 (t=0.1)
 TERMINAL : PHOSPHOR BRONZE (t=0.1)
 金具：りん青銅 (t=0.12)
 FITTING NAIL : PHOSPHOR BRONZE (t=0.12)
 吸着テープ：ポリイミド
 VACUUM TAPE : POLYIMIDE

2. メッキ仕様 PLATING

ターミナル TERMINAL
 金メッキ 0.1 マイクロメートル以上
 GOLD 0.1MICROMETER MINIMUM
 下地メッキ：ニッケルメッキ 1.0 マイクロメートル以上
 UNDER PLATING : NICKEL 1.0MICROMETER MINIMUM
 ※コンタクト部とテール部はニッケルメッキによって分断されている金メッキです。
 DIVIDE INTO PARTS THE GOLD PLATING OF THE CONTACT AND THE TAIL PART BY THE NICKEL PLATING.
 ※封孔処理品

金具 FITTING NAIL

フラッシュ金メッキ
 FLASH Au PLATING
 下地メッキ：ニッケルメッキ 1.0 マイクロメートル以上
 UNDER PLATING : NICKEL 1.0MICROMETER MINIMUM

③ (全極数 / 2) = 偶数の場合に適用。
 APPLY FOR (CIRCUIT/2)=EVEN.

4. 嵌合相手： 502430 シリーズ
 MATE WITH : 502430 SERIES.

5. テール平坦度は、0.08 以下

テール及び金具の平坦度は、0.1 以下
 TAIL COPLANARITY TO BE 0.08MAXIMUM.
 TAIL AND FITTING NAIL COPLANARITY TO BE 0.1MAXIMUM.

6. ELV 及び RoHS 適合品
 ELV AND RoHS COMPLIANT.

⑦ 斜線部はパターン書込み禁止範囲と半田禁止範囲を示す。

ただし、斜線部に補強金具と同一配線を配置する場合はレジストを施し、この部分に半田は無きこと。
 NO PATTERN CIRCUIT AND NO SOLDER ALLOWED IN THE SHADED AREA.
 HOWEVER, IF NEEDED TO ADD A TRACE OF THE SAME CIRCUIT, PUT THE SOLDER-RESIST, YET NO SOLDER ALLOWED IN THE AREA.

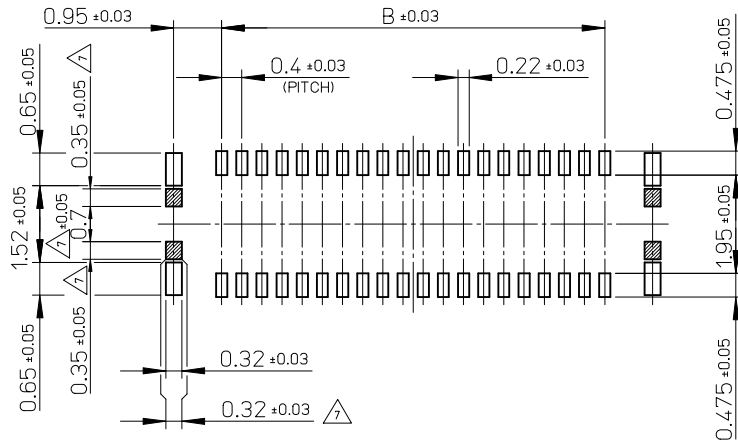

P.C. BOARD PATTERN LAYOUT
 (REFERENCE)

REVISED EC NO: J2009-0889 DRWN: YA0YAGI 2009/06/15 CHKD: THARUYAMA 2009/06/15 APPR: NUKITA 2009/06/15	GENERAL TOLERANCES (UNLESS SPECIFIED)		DIMENSION STYLE MM ONLY	SCALE 10:1	DESIGN UNITS METRIC	THIRD ANGLE PROJECTION
	10 UNDER	±---	DRAWN BY RTAKEUCHI	DATE 2007/12/26	TITLE 0.4 B-TO-B CONN. HGT=1.0 W=2.6 REC ASSY WITH TAPE	
	10 OVER 30 UNDER	±---	CHECKED BY MSASAO	DATE 2007/12/26	MOLEX INCORPORATED	
	30 OVER	±---	APPROVED BY MSASAO	DATE 2007/12/26		
ANGULAR	±---°	MATERIAL NO. SEE SHEET 1	DOCUMENT NO. SD-502426-003		SHEET NO. 2 OF 2	
DRAFT WHERE APPLICABLE MUST REMAIN WITHIN DIMENSIONS		SIZE A3	THIS DRAWING CONTAINS INFORMATION THAT IS PROPRIETARY TO MOLEX INCORPORATED AND SHOULD NOT BE USED WITHOUT WRITTEN PERMISSION			

注記 NOTES

- 製品詳細寸法については製品単体図面を参照下さい。
RE DETAILED DIMENSION, SEE PRODUCT DRAWING.
- 梱包数量: 3000 個/リール
NUMBER OF CONNECTORS: 3000PCS/REEL
- リードテープ長さ LEAD TAPE LENGTH

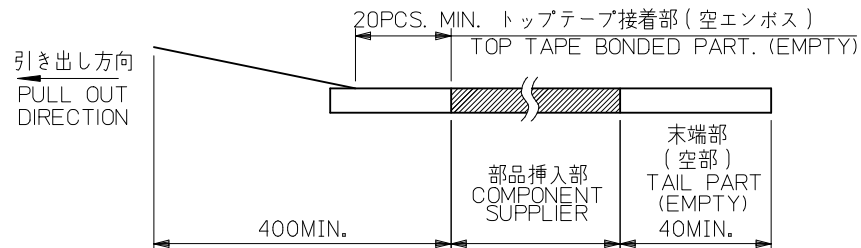
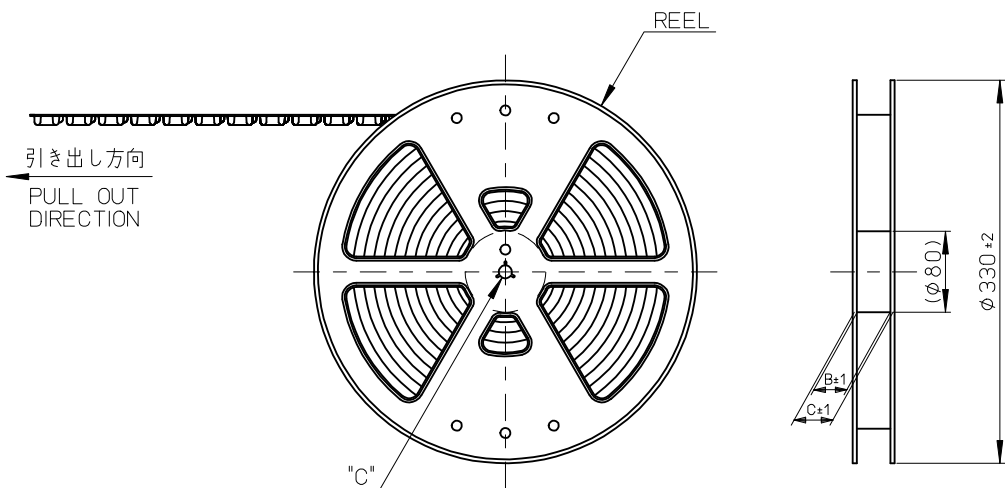

- 材料 MATERIAL
 キャリアテープ (CARRIER TAPE): ポリスチレン (POLYSTYRENE)
 トップテープ (TOP TAPE): PET, PE, PEF
 リール (REEL): ポリスチレン (PS) <リサイクル材を含む>
 POLYSTYRENE (PS) <RECYCLE MATERIAL CONTAINED>
- ELV 及び RoHS適合品
 ELV AND RoHS COMPLIANT

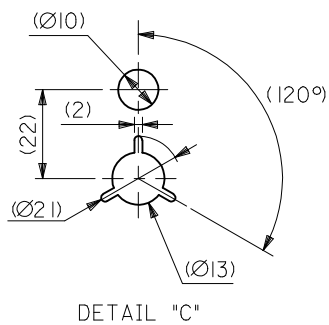

REVISED EC NO: J2009-0889 DRWN: YA0YAGI 2009/06/15 CHKD: THARUYAMA 2009/06/15 APPR: NUKITA 2009/06/15	GENERAL TOLERANCES (UNLESS SPECIFIED)		DIMENSION STYLE MM ONLY	SCALE ---	MODEL NO. 502426-***30
	10 UNDER ± ---		DRAWN BY RTAKEUCHI	DATE 2007/12/26	DESIGN UNITS METRIC
	10 OVER 30 UNDER ± ---		CHECKED BY MSASAO	DATE 2007/12/26	
	30 OVER ± ---		APPROVED BY MSASAO	DATE 2007/12/26	MATERIAL NO. SEE TABLE
ANGULAR ± --- °		DRAWN BY RTAKEUCHI		DATE 2007/12/26	
DRAFT WHERE APPLICABLE MUST REMAIN WITHIN DIMENSIONS		MATERIAL NO. SEE TABLE		DOCUMENT NO. SD-502426-004	MATERIAL NO. SEE TABLE
		SIZE A3		THIS DRAWING CONTAINS INFORMATION THAT IS PROPRIETARY TO MOLEX INCORPORATED AND SHOULD NOT BE USED WITHOUT WRITTEN PERMISSION	

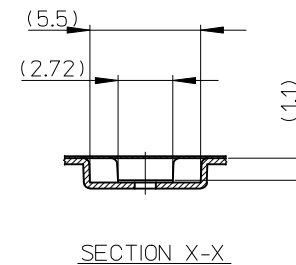
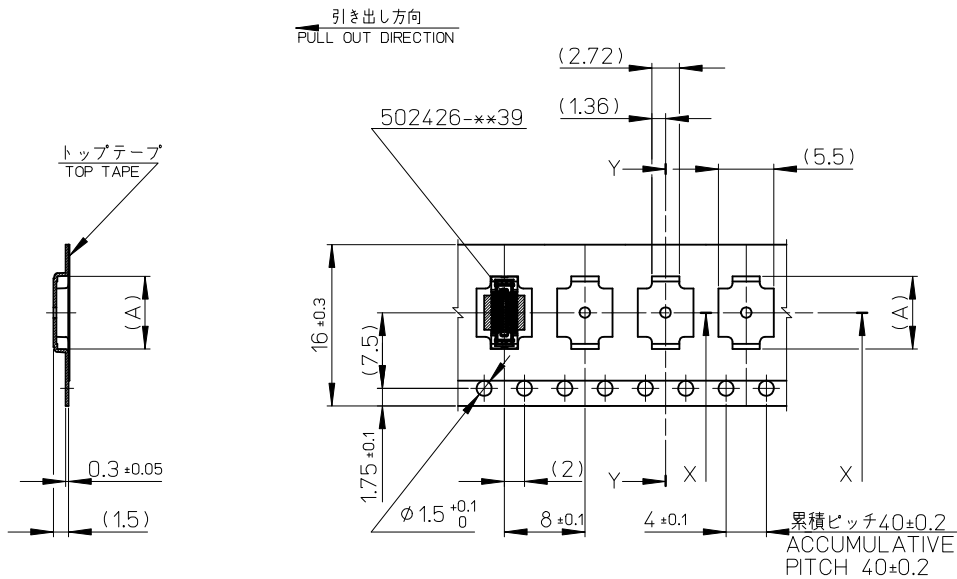

SECTION Y-Y

16mm 幅キャリアテープ
16mm WIDTH CARRIER TAPE

16	21.4	17.4	8.42	502426-2630	26
			8.02	502426-2430	24
			7.62	502426-2230	22
			7.22	502426-2030	20
			6.02	502426-1430	14
キャリアテープ幅 CARRIER TAPE WIDTH			C	B	(A)
			MATERIAL No.		CKT.
			MODEL No.		502426-***30

REVISED EC NO: J2009-0889 DRWN: YA0YAGI 2009/06/15 CHKD: THARUYAMA 2009/06/15 APPR: NUKITA 2009/06/15	DESCRIPTION REV	GENERAL TOLERANCES (UNLESS SPECIFIED)		DIMENSION STYLE MM ONLY		SCALE ---	DESIGN UNITS METRIC	THIRD ANGLE PROJECTION	
		10 UNDER	±---	DRAWN BY RTAKEUCHI	DATE 2007/12/26	TITLE 0.4 B-TO-B CONN. HGT=1.0 REC ASSY WITH TAPE EMBSTP PKG			
		10 OVER 30 UNDER	±---	CHECKED BY MSASAO	DATE 2007/12/26	MOLEX INCORPORATED			
		30 OVER	±---	APPROVED BY MSASAO	DATE 2007/12/26	DOCUMENT NO. SD-502426-004			
ANGULAR ±---°		DRAFT WHERE APPLICABLE MUST REMAIN WITHIN DIMENSIONS		MATERIAL NO. SEE TABLE		SHEET NO. 2 OF 4		THIS DRAWING CONTAINS INFORMATION THAT IS PROPRIETARY TO MOLEX INCORPORATED AND SHOULD NOT BE USED WITHOUT WRITTEN PERMISSION	

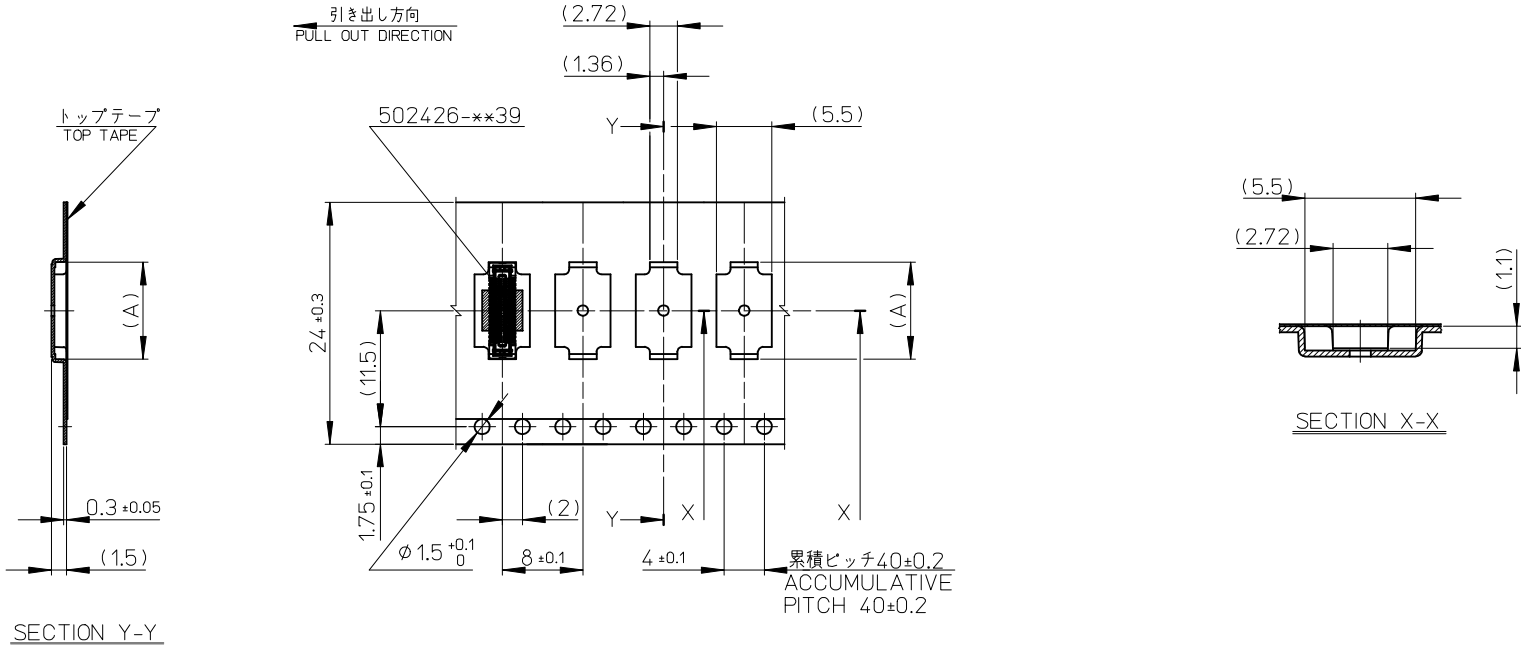

24mm 幅キャリアテープ
24mm WIDTH CARRIER TAPE

24	29.4	25.4	15.22	502426-6030	60
			13.22	502426-5030	50
			11.22	502426-4030	40
			9.62	502426-3230	32
キャリアテープ幅 CARRIER TAPE WIDTH			(A)	MATERIAL No.	CKT.
			MODEL No.	502426-**-30	

REVISED EC NO: J2009-0889 DRWN: YA0YAGI 2009/06/15 CHK'D: THARUYAMA 2009/06/15 APPR: NUKITA 2009/06/15	DESCRIPTION REV	GENERAL TOLERANCES (UNLESS SPECIFIED)		DIMENSION STYLE MM ONLY		SCALE ---	DESIGN UNITS METRIC	THIRD ANGLE PROJECTION		
		10 UNDER	±---	DRAWN BY RTAKEUCHI	DATE 2007/12/26	TITLE 0.4 B-TO-B CONN. HGT=1.0 REC ASSY WITH TAPE EMBSTP PKG				
		10 OVER 30 UNDER	±---	CHECKED BY MSASAO	DATE 2007/12/26	MOLEX INCORPORATED				
		30 OVER	±---	APPROVED BY MSASAO	DATE 2007/12/26	DOCUMENT NO. SD-502426-004				
		ANGULAR	±---°	MATERIAL NO. SEE TABLE		SHEET NO. 3 OF 4				
DRAFT WHERE APPLICABLE MUST REMAIN WITHIN DIMENSIONS		THIS DRAWING CONTAINS INFORMATION THAT IS PROPRIETARY TO MOLEX INCORPORATED AND SHOULD NOT BE USED WITHOUT WRITTEN PERMISSION								

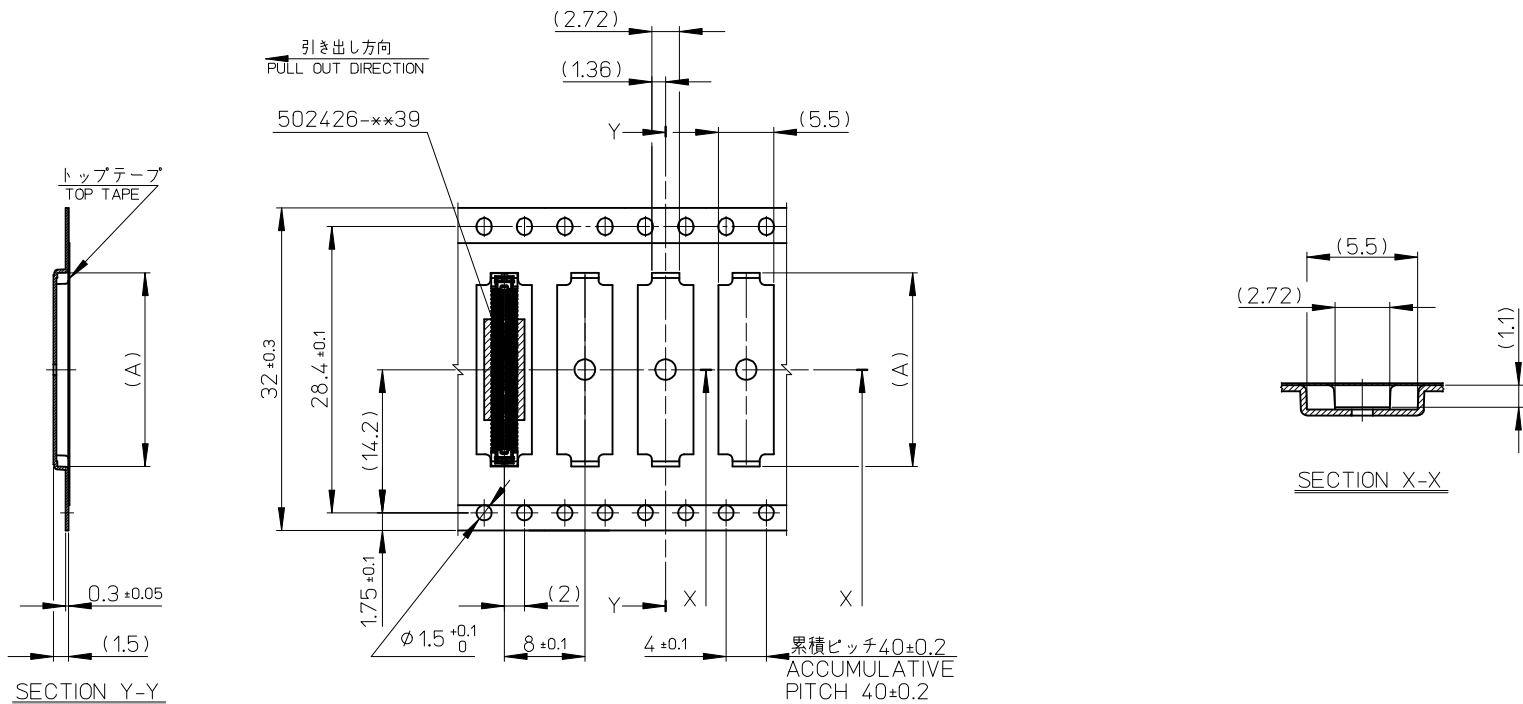

32mm 幅キャリアテープ
32mm WIDTH CARRIER TAPE

32	37.4	33.5	21.22	502426-9030	90
			19.22	502426-8030	80
			17.22	502426-7030	70
キャリアテープ幅 CARRIER TAPE WIDTH			C	B	(A)
			MATERIAL No.		CKT.
			MODEL No.		502426-**30

REVISED EC NO: J2009-0889 DRWN: YAOYAGI 2009/06/15 CHKD: THARUYAMA 2009/06/15 APPR: NUKITA 2009/06/15	DESCRIPTION REV	GENERAL TOLERANCES (UNLESS SPECIFIED)		DIMENSION STYLE MM ONLY		SCALE ---	DESIGN UNITS METRIC	THIRD ANGLE PROJECTION		
		10 UNDER	±---	DRAWN BY RTAKEUCHI	DATE 2007/12/26	TITLE 0.4 B-TO-B CONN. HGT=1.0 REC ASSY WITH TAPE EMBSTP PKG				
		10 OVER 30 UNDER	±---	CHECKED BY MSASAO	DATE 2007/12/26	MOLEX INCORPORATED				
		30 OVER	±---	APPROVED BY MSASAO	DATE 2007/12/26	DOCUMENT NO. SD-502426-004				
ANGULAR ±---° DRAFT WHERE APPLICABLE MUST REMAIN WITHIN DIMENSIONS		MATERIAL NO. SEE TABLE		SIZE A3		SHEET NO. 4 OF 4				



Компания «ЭлектроПласт» предлагает заключение долгосрочных отношений при поставках импортных электронных компонентов на взаимовыгодных условиях!

Наши преимущества:

- Оперативные поставки широкого спектра электронных компонентов отечественного и импортного производства напрямую от производителей и с крупнейших мировых складов;
- Поставка более 17-ти миллионов наименований электронных компонентов;
- Поставка сложных, дефицитных, либо снятых с производства позиций;
- Оперативные сроки поставки под заказ (от 5 рабочих дней);
- Экспресс доставка в любую точку России;
- Техническая поддержка проекта, помощь в подборе аналогов, поставка прототипов;
- Система менеджмента качества сертифицирована по Международному стандарту ISO 9001;
- Лицензия ФСБ на осуществление работ с использованием сведений, составляющих государственную тайну;
- Поставка специализированных компонентов (Xilinx, Altera, Analog Devices, Intersil, Interpoint, Microsemi, Aeroflex, Peregrine, Syfer, Eurofarad, Texas Instrument, Miteq, Cobham, E2V, MA-COM, Hittite, Mini-Circuits, General Dynamics и др.);

Помимо этого, одним из направлений компании «ЭлектроПласт» является направление «Источники питания». Мы предлагаем Вам помощь Конструкторского отдела:

- Подбор оптимального решения, техническое обоснование при выборе компонента;
- Подбор аналогов;
- Консультации по применению компонента;
- Поставка образцов и прототипов;
- Техническая поддержка проекта;
- Защита от снятия компонента с производства.



Как с нами связаться

Телефон: 8 (812) 309 58 32 (многоканальный)

Факс: 8 (812) 320-02-42

Электронная почта: org@eplast1.ru

Адрес: 198099, г. Санкт-Петербург, ул. Калинина, дом 2, корпус 4, литера А.