



MICROCHIP

**EVB-LAN9252-ADD-ON
for Beckhoff EL9800
User's Guide**

Note the following details of the code protection feature on Microchip devices:

- Microchip products meet the specification contained in their particular Microchip Data Sheet.
- Microchip believes that its family of products is one of the most secure families of its kind on the market today, when used in the intended manner and under normal conditions.
- There are dishonest and possibly illegal methods used to breach the code protection feature. All of these methods, to our knowledge, require using the Microchip products in a manner outside the operating specifications contained in Microchip's Data Sheets. Most likely, the person doing so is engaged in theft of intellectual property.
- Microchip is willing to work with the customer who is concerned about the integrity of their code.
- Neither Microchip nor any other semiconductor manufacturer can guarantee the security of their code. Code protection does not mean that we are guaranteeing the product as "unbreakable."

Code protection is constantly evolving. We at Microchip are committed to continuously improving the code protection features of our products. Attempts to break Microchip's code protection feature may be a violation of the Digital Millennium Copyright Act. If such acts allow unauthorized access to your software or other copyrighted work, you may have a right to sue for relief under that Act.

Information contained in this publication regarding device applications and the like is provided only for your convenience and may be superseded by updates. It is your responsibility to ensure that your application meets with your specifications. MICROCHIP MAKES NO REPRESENTATIONS OR WARRANTIES OF ANY KIND WHETHER EXPRESS OR IMPLIED, WRITTEN OR ORAL, STATUTORY OR OTHERWISE, RELATED TO THE INFORMATION, INCLUDING BUT NOT LIMITED TO ITS CONDITION, QUALITY, PERFORMANCE, MERCHANTABILITY OR FITNESS FOR PURPOSE. Microchip disclaims all liability arising from this information and its use. Use of Microchip devices in life support and/or safety applications is entirely at the buyer's risk, and the buyer agrees to defend, indemnify and hold harmless Microchip from any and all damages, claims, suits, or expenses resulting from such use. No licenses are conveyed, implicitly or otherwise, under any Microchip intellectual property rights unless otherwise stated.

Trademarks

The Microchip name and logo, the Microchip logo, dsPIC, FlashFlex, flexPWR, JukeBlox, KEELOQ, KEELOQ logo, Kleer, LANCheck, MediaLB, MOST, MOST logo, MPLAB, OptoLyzer, PIC, PICSTART, PIC³² logo, RightTouch, SpyNIC, SST, SST Logo, SuperFlash and UNI/O are registered trademarks of Microchip Technology Incorporated in the U.S.A. and other countries.

The Embedded Control Solutions Company and mTouch are registered trademarks of Microchip Technology Incorporated in the U.S.A.

Analog-for-the-Digital Age, BodyCom, chipKIT, chipKIT logo, CodeGuard, dsPICDEM, dsPICDEM.net, ECAN, In-Circuit Serial Programming, ICSP, Inter-Chip Connectivity, KleerNet, KleerNet logo, MiWi, motorBench, MPASM, MPF, MPLAB Certified logo, MPLIB, MPLINK, MultiTRAK, NetDetach, Omniscient Code Generation, PICDEM, PICDEM.net, PICkit, PICtail, RightTouch logo, REAL ICE, SQI, Serial Quad I/O, Total Endurance, TSHARC, USBCheck, VariSense, ViewSpan, WiperLock, Wireless DNA, and ZENA are trademarks of Microchip Technology Incorporated in the U.S.A. and other countries.

SQTP is a service mark of Microchip Technology Incorporated in the U.S.A.

Silicon Storage Technology is a registered trademark of Microchip Technology Inc. in other countries.

GestIC is a registered trademark of Microchip Technology Germany II GmbH & Co. KG, a subsidiary of Microchip Technology Inc., in other countries.

All other trademarks mentioned herein are property of their respective companies.

© 2015, Microchip Technology Incorporated, Printed in the U.S.A., All Rights Reserved.

ISBN: 978-1-63277-871-0

**QUALITY MANAGEMENT SYSTEM
CERTIFIED BY DNV
= ISO/TS 16949 =**

Microchip received ISO/TS-16949:2009 certification for its worldwide headquarters, design and wafer fabrication facilities in Chandler and Tempe, Arizona; Gresham, Oregon and design centers in California and India. The Company's quality system processes and procedures are for its PIC® MCUs and dsPIC® DSCs, KEELOQ® code hopping devices, Serial EEPROMs, microperipherals, nonvolatile memory and analog products. In addition, Microchip's quality system for the design and manufacture of development systems is ISO 9001:2000 certified.

Object of Declaration: EVB-LAN9252-ADD-ON for Beckhoff EL9800

EU Declaration of Conformity

Manufacturer: Microchip Technology Inc.
2355 W. Chandler Blvd.
Chandler, Arizona, 85224-6199
USA

This declaration of conformity is issued by the manufacturer.

The development/evaluation tool is designed to be used for research and development in a laboratory environment. This development/evaluation tool is not a Finished Appliance, nor is it intended for incorporation into Finished Appliances that are made commercially available as single functional units to end users under EU EMC Directive 2004/108/EC and as supported by the European Commission's Guide for the EMC Directive 2004/108/EC (8th February 2010).

This development/evaluation tool complies with EU RoHS2 Directive 2011/65/EU.

This development/evaluation tool, when incorporating wireless and radio-telecom functionality, is in compliance with the essential requirement and other relevant provisions of the R&TTE Directive 1999/5/EC and the FCC rules as stated in the declaration of conformity provided in the module datasheet and the module product page available at www.microchip.com.

For information regarding the exclusive, limited warranties applicable to Microchip products, please see Microchip's standard terms and conditions of sale, which are printed on our sales documentation and available at www.microchip.com.

Signed for and on behalf of Microchip Technology Inc. at Chandler, Arizona, USA

Derek Carlson
VP Development Tools

12-Sep-14
Date

NOTES:

Table of Contents

Preface	6
Introduction.....	6
Document Layout	6
Conventions Used in this Guide	7
The Microchip Web Site	8
Development Systems Customer Change Notification Service	8
Customer Support	9
Document Revision History	9
Chapter 1. Overview	
1.1 Introduction	11
1.2 References	12
1.3 Terms and Abbreviations	12
Chapter 2. Board Details & Configuration	
2.1 Power	13
2.2 Board-to-Board Connector Pinout	13
2.3 Clock	14
2.4 Configuration	14
2.5 Strap Options	15
2.5.1 Chip Mode	15
2.5.2 EEPROM Size Configuration	15
2.6 Process Data Interfaces	15
2.6.1 PDI Configuration on the EVB-LAN9252-ADD-ON	16
2.6.2 Configuring PDI Selection on the Beckhoff EL9800	21
2.7 Mechanicals	22
Appendix A. Evaluation Board Photo	
A.1 Introduction	23
Appendix B. Evaluation Board Schematics	
B.1 Introduction	25
Appendix C. Bill of Materials (BOM)	
C.1 Introduction	29
Worldwide Sales and Service	32

Preface

NOTICE TO CUSTOMERS

All documentation becomes dated, and this manual is no exception. Microchip tools and documentation are constantly evolving to meet customer needs, so some actual dialogs and/or tool descriptions may differ from those in this document. Please refer to our web site (www.microchip.com) to obtain the latest documentation available.

Documents are identified with a “DS” number. This number is located on the bottom of each page, in front of the page number. The numbering convention for the DS number is “DSXXXXA”, where “XXXX” is the document number and “A” is the revision level of the document.

For the most up-to-date information on development tools, see the MPLAB® IDE online help. Select the Help menu, and then Topics to open a list of available online help files.

INTRODUCTION

This chapter contains general information that will be useful to know before using the EVB-LAN9252-ADD-ON. Items discussed in this chapter include:

- [Document Layout](#)
- [Conventions Used in this Guide](#)
- [The Microchip Web Site](#)
- [Development Systems Customer Change Notification Service](#)
- [Customer Support](#)
- [Document Revision History](#)

DOCUMENT LAYOUT

This document describes how to use the EVB-LAN9252-ADD-ON as a development tool for the Microchip LAN9252 EtherCAT® slave controller. The manual layout is as follows:

- **Chapter 1. “Overview”** – Provides a brief description of the EVB-LAN9252-ADD-ON.
- **Chapter 2. “Board Details & Configuration”** – Includes details and instructions for using the EVB-LAN9252-ADD-ON.
- **Appendix A. “Evaluation Board Photo”** – This appendix shows the EVB-LAN9252-ADD-ON.
- **Appendix B. “Evaluation Board Schematics”** – This appendix shows the EVB-LAN9252-ADD-ON schematics.
- **Appendix C. “Bill of Materials (BOM)”** – This appendix includes the EVB-LAN9252-ADD-ON Bill of Materials (BOM).

CONVENTIONS USED IN THIS GUIDE

This manual uses the following documentation conventions:

DOCUMENTATION CONVENTIONS

Description	Represents	Examples
Arial font:		
Italic characters	Referenced books	<i>MPLAB[®] IDE User's Guide</i>
	Emphasized text	...is the <i>only</i> compiler...
Initial caps	A window	the Output window
	A dialog	the Settings dialog
	A menu selection	select Enable Programmer
Quotes	A field name in a window or dialog	"Save project before build"
Underlined, italic text with right angle bracket	A menu path	<u><i>File>Save</i></u>
Bold characters	A dialog button	Click OK
	A tab	Click the Power tab
N'Rnnnn	A number in verilog format, where N is the total number of digits, R is the radix and n is a digit.	4'b0010, 2'hF1
Text in angle brackets < >	A key on the keyboard	Press <Enter>, <F1>
Courier New font:		
Plain Courier New	Sample source code	#define START
	Filenames	autoexec.bat
	File paths	c:\mcc18\h
	Keywords	_asm, _endasm, static
	Command-line options	-Opa+, -Opa-
	Bit values	0, 1
	Constants	0xFF, 'A'
Italic Courier New	A variable argument	<i>file.o</i> , where <i>file</i> can be any valid filename
Square brackets []	Optional arguments	mcc18 [options] <i>file</i> [options]
Curly brackets and pipe character: { }	Choice of mutually exclusive arguments; an OR selection	errorlevel {0 1}
Ellipses...	Replaces repeated text	var_name [, var_name...]
	Represents code supplied by user	void main (void) { ... }

THE MICROCHIP WEB SITE

Microchip provides online support via our web site at www.microchip.com. This web site is used as a means to make files and information easily available to customers. Accessible by using your favorite Internet browser, the web site contains the following information:

- **Product Support** – Data sheets and errata, application notes and sample programs, design resources, user's guides and hardware support documents, latest software releases and archived software
- **General Technical Support** – Frequently Asked Questions (FAQs), technical support requests, online discussion groups, Microchip consultant program member listing
- **Business of Microchip** – Product selector and ordering guides, latest Microchip press releases, listing of seminars and events, listings of Microchip sales offices, distributors and factory representatives

DEVELOPMENT SYSTEMS CUSTOMER CHANGE NOTIFICATION SERVICE

Microchip's customer notification service helps keep customers current on Microchip products. Subscribers will receive e-mail notification whenever there are changes, updates, revisions or errata related to a specified product family or development tool of interest.

To register, access the Microchip web site at www.microchip.com, click on Customer Change Notification and follow the registration instructions.

The Development Systems product group categories are:

- **Compilers** – The latest information on Microchip C compilers, assemblers, linkers and other language tools. These include all MPLAB C compilers; all MPLAB assemblers (including MPASM assembler); all MPLAB linkers (including MPLINK object linker); and all MPLAB librarians (including MPLIB object librarian).
- **Emulators** – The latest information on Microchip in-circuit emulators. This includes the MPLAB REAL ICE and MPLAB ICE 2000 in-circuit emulators.
- **In-Circuit Debuggers** – The latest information on the Microchip in-circuit debuggers. This includes MPLAB ICD 3 in-circuit debuggers and PICkit 3 debug express.
- **MPLAB IDE** – The latest information on Microchip MPLAB IDE, the Windows Integrated Development Environment for development systems tools. This list is focused on the MPLAB IDE, MPLAB IDE Project Manager, MPLAB Editor and MPLAB SIM simulator, as well as general editing and debugging features.
- **Programmers** – The latest information on Microchip programmers. These include production programmers such as MPLAB REAL ICE in-circuit emulator, MPLAB ICD 3 in-circuit debugger and MPLAB PM3 device programmers. Also included are nonproduction development programmers such as PICSTART Plus and PIC-kit 2 and 3.

CUSTOMER SUPPORT

Users of Microchip products can receive assistance through several channels:

- Distributor or Representative
- Local Sales Office
- Field Application Engineer (FAE)
- Technical Support

Customers should contact their distributor, representative or field application engineer (FAE) for support. Local sales offices are also available to help customers. A listing of sales offices and locations is included in the back of this document.

Technical support is available through the web site at:

<http://www.microchip.com/support>

DOCUMENT REVISION HISTORY

Revision	Section/Figure/Entry	Correction
DS50002356A (03-19-15)	Initial Release of document.	
DS50002356B (10-08-15)	(Throughout document.)	Updated EVB-LAN9252-BECKHOFF-ADD-ON to EVB-LAN9252-ADD-ON.
	Section 1.1 “Introduction”	Updated/replaced entire introduction.
	Figure 1-1	Updated image.
	Section 1.3 “Terms and Abbreviations”	Updated definition of EVB. Added definition for DIGIO.
	Section 2.1 “Power”	Updated/replaced entire paragraph.
	Section 2.2 “Board-to-Board Connector Pinout”	Updated/replaced entire paragraph.
	Table 2-1	Updated title, fixed arrangement of Pin Numbers.
	Section 2.4 “Resets”	Removed entirely; numbering of succeeding sections updated as a result.
	Section 2.4 “Configuration”	Updated first paragraph to include REV B.
	Figure 2-1	Updated image.
	Figure 2-2	Updated image.
	Section 2.5.1 “Chip Mode”	Updated title. Updated/replaced entire paragraph.
	Section 2.6 “Process Data Interfaces”	Updated first paragraph, second bullet point and note.
	Section 2.6.1.1.1 “SPI Mode”	Updated/replaced entire SPI Mode section including tables.
	Section 2.6.1.1.2 “DIGIO Mode”	Updated/replaced entire DIGIO Mode section including tables.
	Section 2.6.1.2 “EVB-LAN9252-ADD-ON Software Configuration”	Updated step 1 to add definition for ESI.
	Figure 2-6	Updated image.
	Figure 2-7	Updated image.
	Figure 2-8	Updated image.
	Section 2.6.2 “Configuring PDI Selection on the Beckhoff EL9800”	Added note.
	Figure B-1	Updated schematic.
	Figure B-2	Updated schematic.

Revision	Section/Figure/Entry	Correction
	Figure B-3	Updated schematic.
	Table C-1	Updated BOM.
	Table C-2	Updated BOM - DNP Components.

Chapter 1. Overview

1.1 INTRODUCTION

The LAN9252 is a 2-port EtherCAT[®] Slave Controller (ESC) with dual-integrated Ethernet PHYs which each contain a full-duplex 100BASE-TX transceiver and support 100Mbps (100BASE-TX) operation. 100BASE-FX is supported via an external fiber transceiver.

The EtherCAT module implements a 3 port EtherCAT slave controller with 4K bytes of Dual Port memory (DPRAM), 4 SyncManagers, 3 Fieldbus Memory Management Units (FMMUs) and a 64-bit Distributed Clock.

This document details the various sections of the EVB-LAN9252-ADD-ON, which is designed to be used as an add-on board (ESC board) with the Beckhoff EL9800 EtherCAT Evaluation Board.

This board supports the SPI and DIGIO PDI modes of the LAN9252 board, combining a LAN9252 EtherCAT Slave Controller, two RJ45 1x1 Tab-DOWN with LEDs, 8-pin integrated magnetics connector (ICM), and a PDI-Connector on a printed circuit board.

A simplified block diagram of the EVB-LAN9252-ADD-ON is displayed in [Figure 1-1](#).

FIGURE 1-1: EVB-LAN9252-ADD-ON BLOCK DIAGRAM

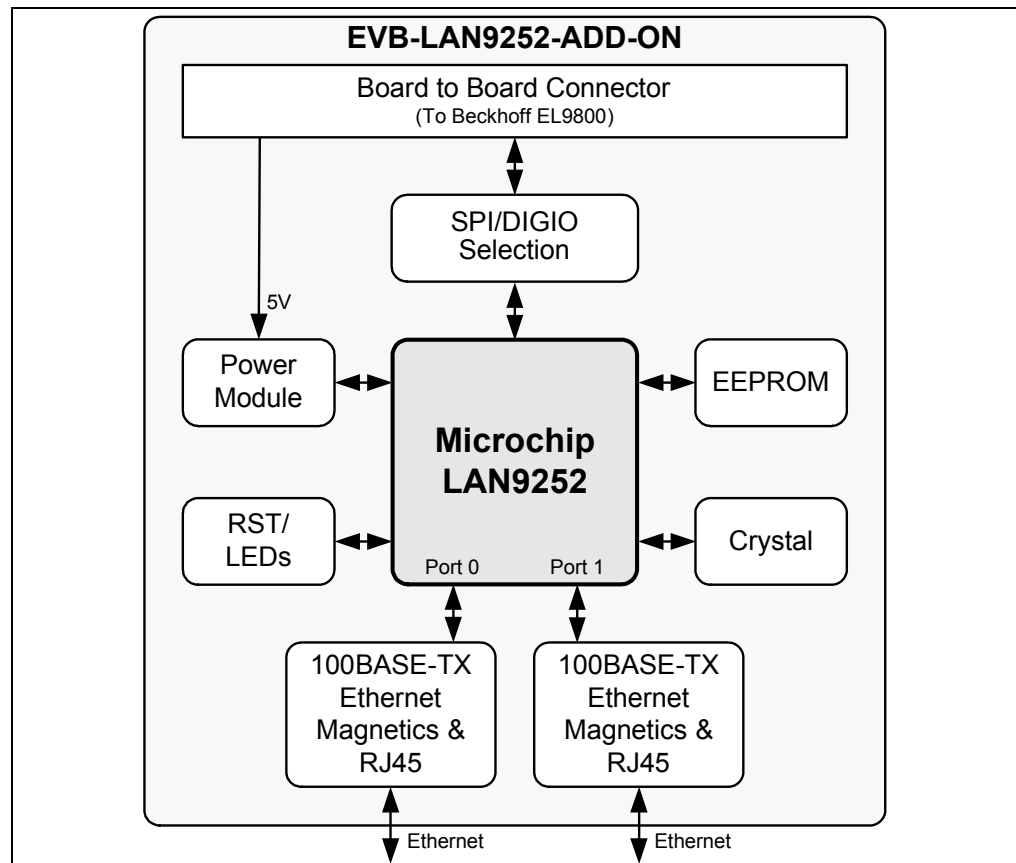

1.2 REFERENCES

Concepts and material available in the following documents may be helpful when reading this document. Visit www.microchip.com for the latest documentation.

- LAN9252 Data Sheet
- Beckhoff EL9800 EtherCAT Base Board Datasheet
- AN 8.13 Suggested Magnetics
- EVB-LAN9252-ADD-ON Schematics

1.3 TERMS AND ABBREVIATIONS

ESC - EtherCAT[®] Slave Controller

EVB - Evaluation Board

HAL - Hardware Abstraction Layer

HBI - Host Bus Interface

IDE - Integrated Development Environment

PDI - Process Data Interface

SPI - Serial Protocol Interface

SSC - Slave Stack Code

DIGIO - Digital Input/Output

Chapter 2. Board Details & Configuration

This chapter includes sub-sections on the following EVB-LAN9252-ADD-ON details:

- Power
- Board-to-Board Connector Pinout
- Clock
- Configuration
- Strap Options
- Process Data Interfaces
- Mechanicals

2.1 POWER

Power is supplied as +5V to the EVB-LAN9252-ADD-ON via the board-to-board connector. +3.3V is generated internally via an LDO. Assertion of the D2 green LED indicates +3.3V o/p. The LAN9252 includes an internal +1.2V regulator which supplies power to the internal core logic.

2.2 BOARD-TO-BOARD CONNECTOR PINOUT

[Table 2-1](#) details the pinout of connector J202 of the EVB-LAN9252 ADD ON board-to-board connector, which connects to the Beckhoff EL9800 J202 connector.

TABLE 2-1: EVB-LAN9252 CONNECTOR J202 PIN OUT

Pin Number	Signal	Pin Number	Signal
1	DIGIO 0	20	GND
2	GND	21	SCS#
3	DIGIO 2	22	NC
4	DIGIO 1	23	NC
5	DIGIO 4	24	NC
6	DIGIO 3	25	NC
7	DIGIO 6	26	NC
8	DIGIO 5	27	GND
9	GND	28	NC
10	DIGIO 7	29	NC
11	DIGIO 9	30	SO
12	DIGIO 8	31	NC
13	DIGIO 11	32	SI
14	DIGIO 10	33	NC
15	DIGIO 13	34	NC
16	DIGIO 12	35	NC
17	DIGIO 15	36	NC
18	DIGIO 14	37	WD_TRIG/SPI_CLK
19	NC	38	GND

TABLE 2-1: EVB-LAN9252 CONNECTOR J202 PIN OUT (CONTINUED)

Pin Number	Signal	Pin Number	Signal
39	SOF	46	OE_EXT
40	OUTVALID	47	NC
41	SYNC/LATCH0	48	VCC_5V_IN
42	NC	49	3V3
43	LATCH_IN	50	VCC_5V_IN
44	SYNC/LATCH1	51	TP3
45	GND	52	TP2

Note: Pins 53-56 are NC.

2.3 CLOCK

LAN9252 requires a fixed-frequency 25MHz clock source for use by the internal clock oscillator and PLL. This is typically provided by attaching a 25MHz crystal to the OSC1 and OSC0 pins.

2.4 CONFIGURATION

The following sub-sections describe the various board features and configuration settings. A top view of the EVB-LAN9252-ADD-ON REV-B is displayed in [Figure 2-1](#).

FIGURE 2-1: EVB-LAN9252-ADD-ON TOP VIEW WITH CALLOUTS

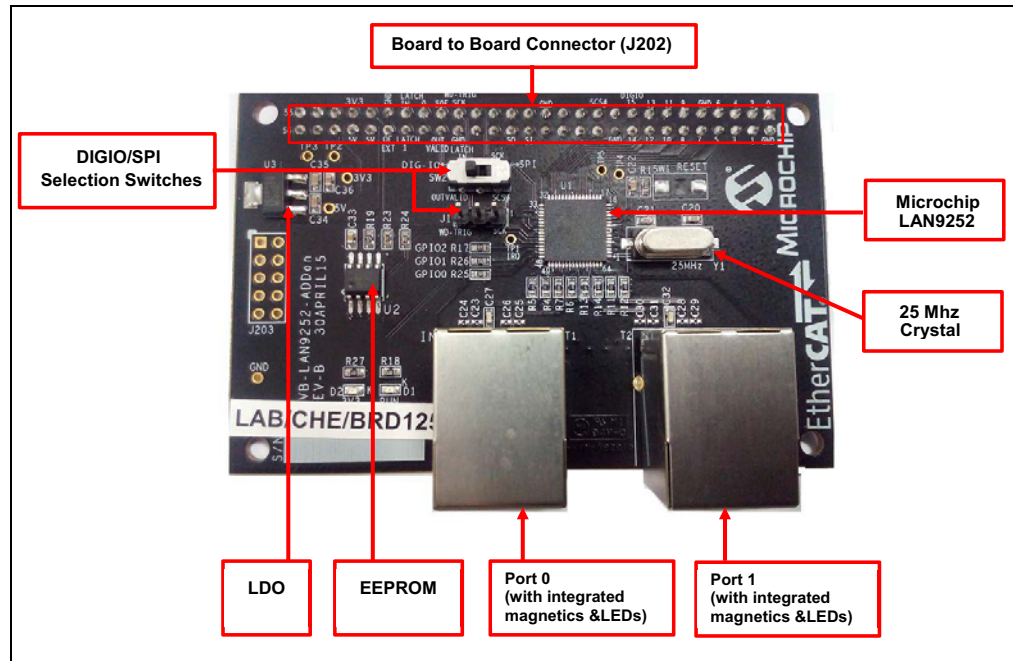

The EVB-LAN9252-ADD-ON connects with the Beckhoff EL9800 EtherCAT Base Board as depicted in [Figure 2-2](#).

FIGURE 2-2: BECKHOFF EL9800

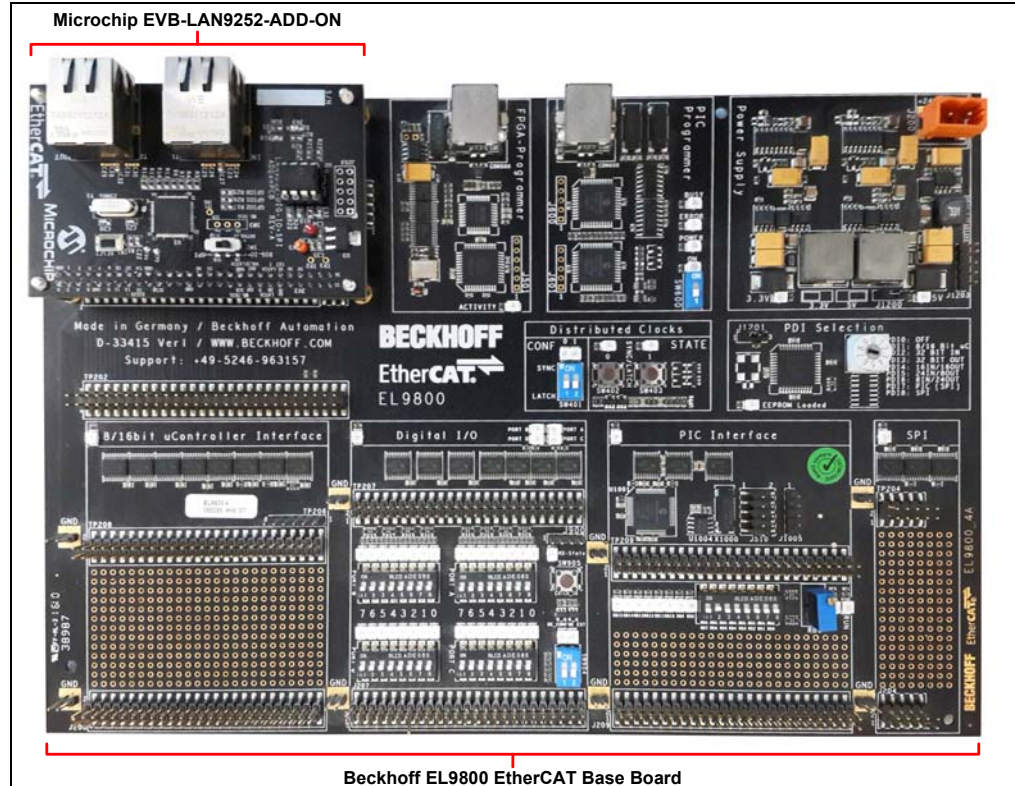

2.5 STRAP OPTIONS

2.5.1 Chip Mode

The chip mode straps determine the number of active ports and port types. EVB-LAN9252 by default, supports only the 2 port mode (CHIP_MODE0 and CHIP_MODE1 signals pulled down).

2.5.2 EEPROM Size Configuration

The EEPROM size configuration strap (LAN9252 E2PSIZE signal) determines the supported EEPROM size range. A low selects 1Kbits (128 x 8) through 16Kbits (2K x 8). A high selects 32Kbits (4K x 8) through 512Kbits (64K x 8) or 4Mbits (512K x 8). On this EVB, E2PSIZE is pulled high to select 512k EEPROM.

2.6 PROCESS DATA INTERFACES

The Process Data Interface is used to communicate with external SoC. The EVB-LAN9252-ADD-ON supports two different PDI configurations:

- SPI
- DIGIO (Default Configuration)

The following section details the hardware and software configurations required for the EVB-LAN9252-ADD-ON and the Beckhoff EL9800 for both PDI configuration options.

Note: Pins 1-2 of J1201 must be shorted on the Beckhoff EL9800 board (under PDI selection area). For DIGIO Switch SW904 must be move to ON position on the Beckhoff EL9800 board (under Digital I/O selection area).

2.6.1 PDI Configuration on the EVB-LAN9252-ADD-ON

2.6.1.1 EVB-LAN9252-ADD-ON BOARD LEVEL CONFIGURATION

2.6.1.1.1 SPI Mode

The SPI Slave module provides a low pin count synchronous slave interface that facilitates communication between the LAN9252 and a host system. The SPI/Slave allows access to the System CSRs, internal FIFOs and registers. It supports single and multiple register read and write commands with incrementing, decrementing and static addressing. Single-bit lane is supported in SPI mode.

The jumper detailed in [Table 2-2](#) and switch detailed in [Table 2-3](#) should be configured as shown in order to use SPI Mode.

TABLE 2-2: SPI MODE JUMPER CONFIGURATION

Jumper	Short Pins
J1	1,2

TABLE 2-3: SPI MODE SWITCH CONFIGURATION

Switch	Short Pins	Knob Position
SW2	1-2, 4-5	Right Side

2.6.1.1.2 DIGIO Mode

For simple modules without microcontrollers, the LAN9252 can operate in Digital IO mode where 16 digital signals can be controlled or monitored by the EtherCAT master. Six control signals are also provided.

The jumper detailed in [Table 2-4](#) and switch detailed in [Table 2-5](#) should be configured as shown in order to use DIGIO Mode.

TABLE 2-4: DIGIO MODE JUMPER CONFIGURATION

Jumper	Short Pins
J1	2,3

TABLE 2-5: DIGIO MODE SWITCH CONFIGURATION

Switch	Short Pins	Knob Position
SW2	2-3, 5-6	Left Side

2.6.1.2 EVB-LAN9252-ADD-ON SOFTWARE CONFIGURATION

To configure the LAN9252 in SPI/DIGIO mode, the appropriate binary files (ESI files) must be programmed into the LAN9252 configuration EEPROM.

The LAN9252 configures itself to the desired mode by reading the strap settings located in EEPROM. The LAN9252 EEPROM is programmed and validated via the TwinCAT master tool. The programming procedure is as follows:

- Note 1:** This example utilizes the TwinCAT tool. Procedures may differ when using other EtherCAT master tools.
- 2:** Ensure the system network properties are configured properly for the EtherCAT frames, Ethernet cable linking your system, and EtherCAT slave board.

Board Details & Configuration

1. Load the corresponding EtherCAT Slave Information (ESI) file in the directory path “C:\TwinCAT\Io\EtherCAT” and select the appropriate ESI file. For this demo, the ESI file for the SPI Mode is used.
2. If TwinCAT installed successfully, a TwinCAT icon will be displayed in the bottom right corner of the desktop. After clicking the icon, a pop-up list will display. Select “System Manager,” as displayed in [Figure 2-3](#).

FIGURE 2-3: TWINCAT SYSTEM MANAGER

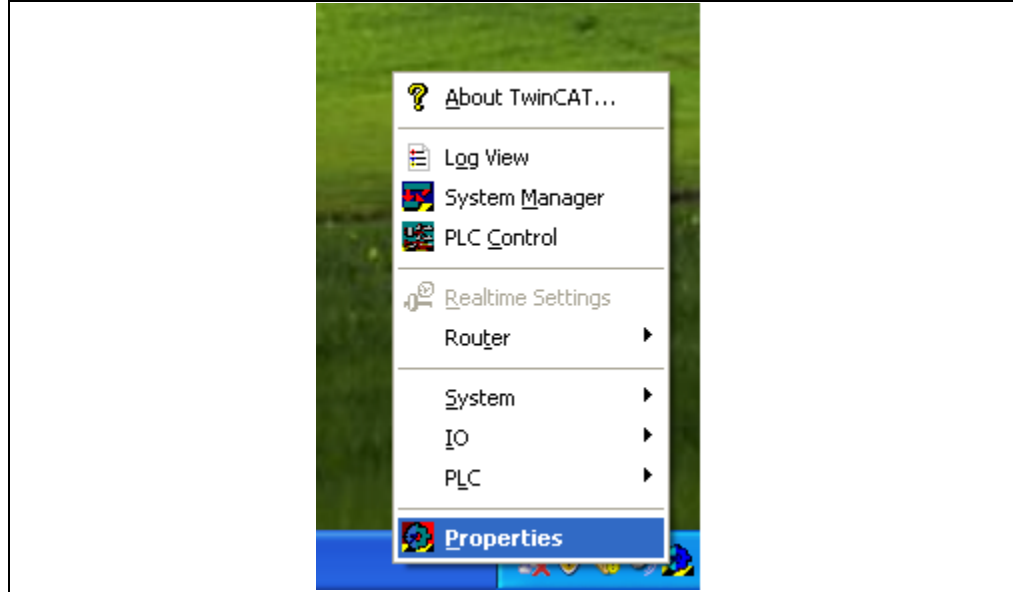

3. If any devices are present, delete them accordingly by clicking the device and selecting “Delete Device”, as displayed in [Figure 2-4](#).

FIGURE 2-4: TWINCAT DELETE DEVICE

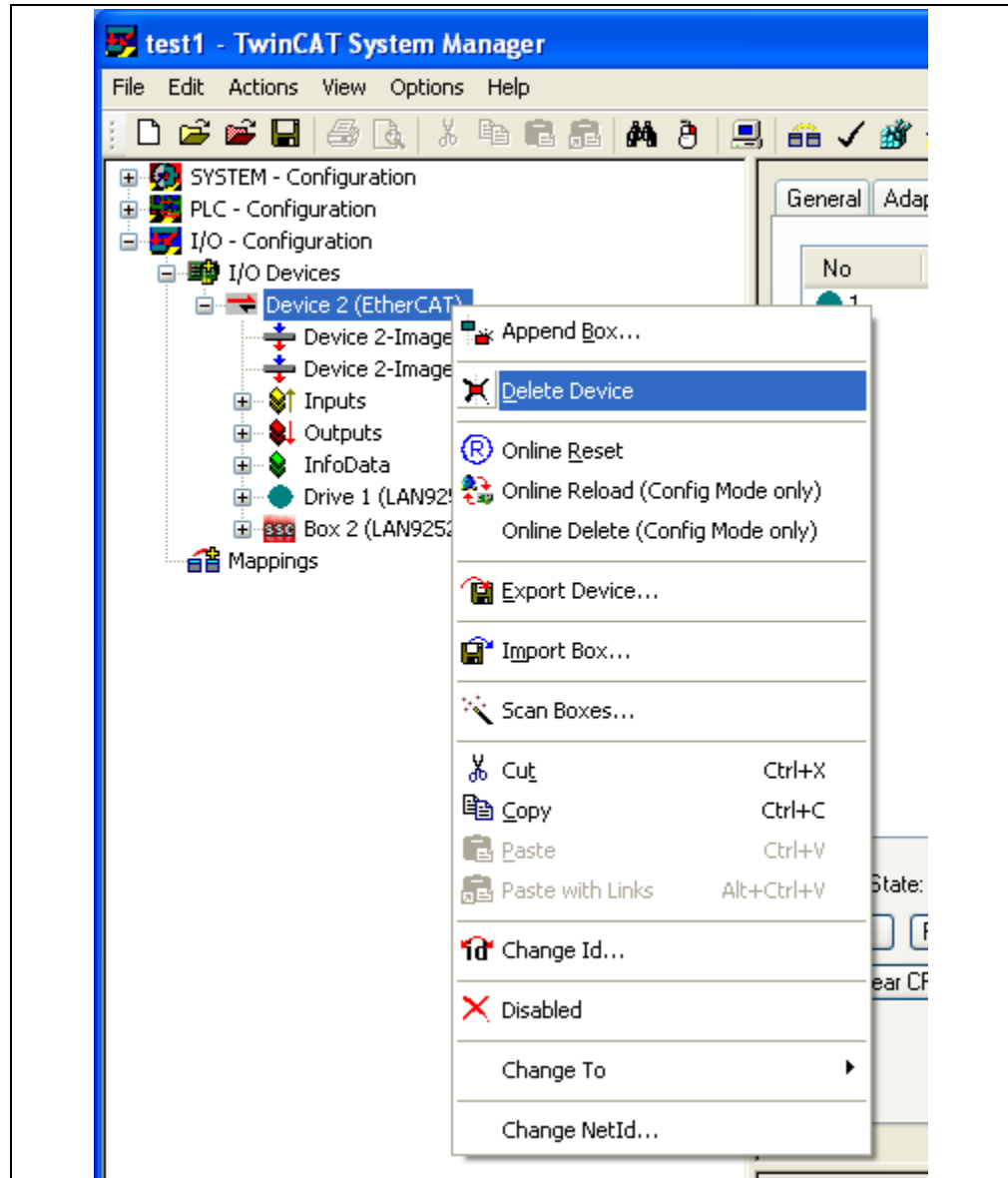

4. Scan for EtherCAT slave devices by clicking "I/O devices" and selecting "Scan Devices", as displayed in [Figure 2-5](#).

FIGURE 2-5: TWINCAT SCAN DEVICES

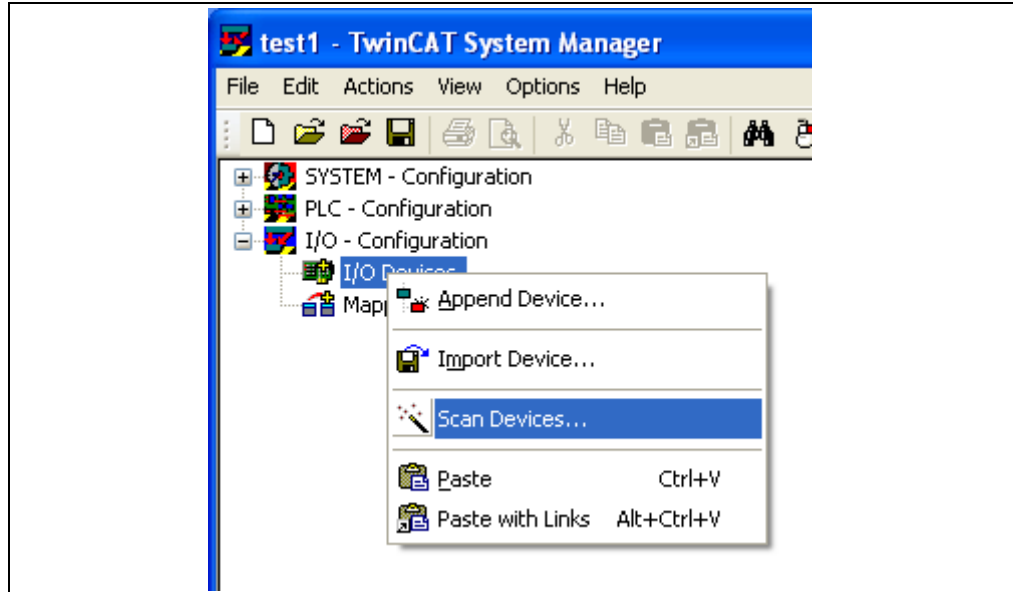

5. After scanning is complete, the right panel of the TwinCAT window will appear as displayed in [Figure 2-6](#).

FIGURE 2-6: TWINCAT DEVICE LIST

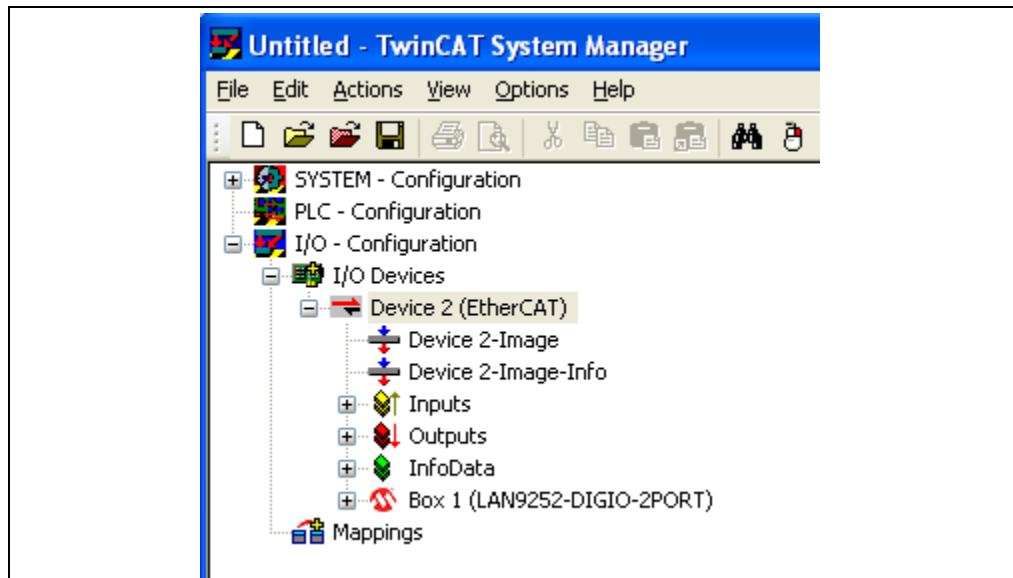

6. After a successful scan, click the “Device 2 (EtherCAT)” drop-down bar on the left panel of the TwinCAT tool (as highlighted in [Figure 2-5](#)). Then click the “Online” tab on the right-side panel of the TwinCAT tool, as displayed in [Figure 2-6](#). Right-click the LAN9252 listing and select “EEPROM Update” from the contextual menu as displayed in [Figure 2-7](#).

FIGURE 2-7: TWINCAT EEPROM UPDATE

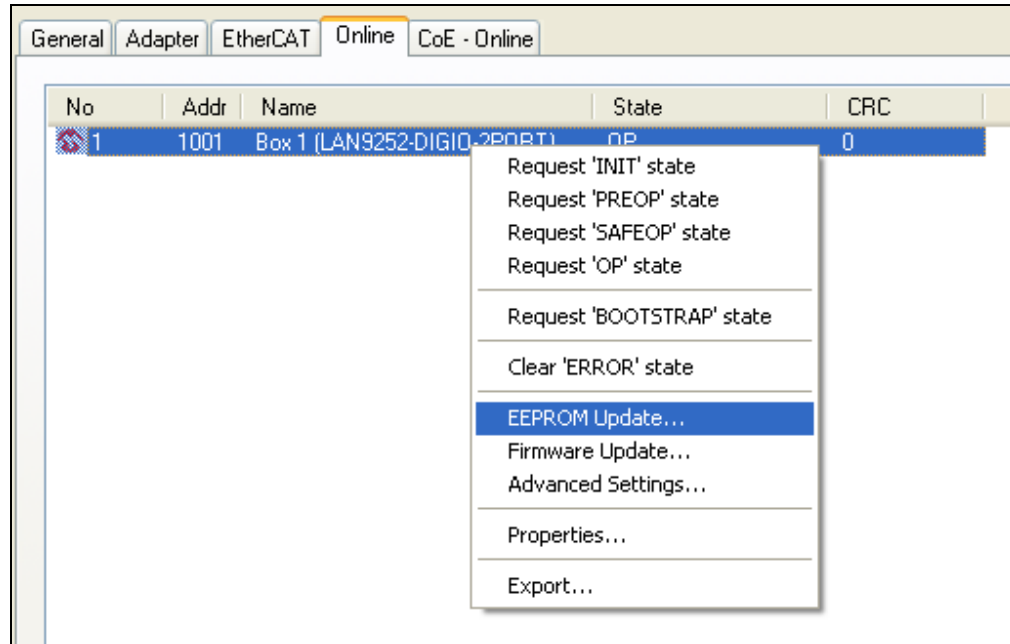

7. Upon selecting “EEPROM Update”, the Write EEPROM window will open. Click the “OK” button to initiate EEPROM programming as displayed in [Figure 2-8](#).

FIGURE 2-8: TWINCAT WRITE EEPROM

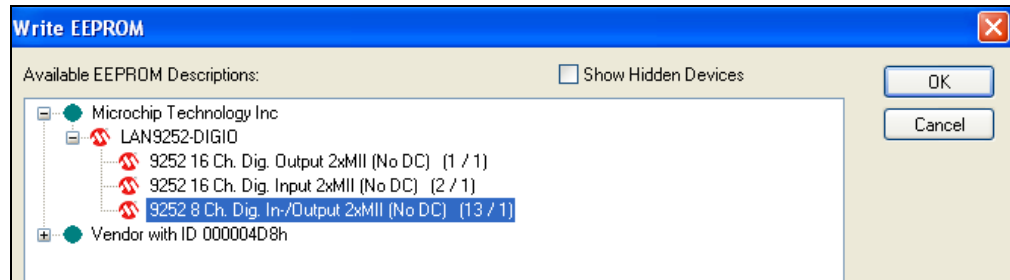

Board Details & Configuration

2.6.2 Configuring PDI Selection on the Beckhoff EL9800

Selection of the different PDIs on the EL9800 takes place using a rotary selector in the PDI-Selection Area. Based on the four physical PDIs, eight logical PDIs are selectable over the PDI-Selector. The selector positions listed in [Table 2-6](#) activate the corresponding PDI.

TABLE 2-6: BECKHOFF EL9800 SELECTOR POSITIONS

Position	Process Data Interface
0	OFF
1	8/16 Bit Microcontroller Interface
2	32-Bit Digital interface - 32 Inputs
3	32-Bit Digital interface - 32 Outputs
4	32-Bit Digital interface - 16 Inputs / 16 Outputs
5	32-Bit Digital interface - 24 Inputs / 8 Outputs
6	32-Bit Digital interface - 8 Inputs / 24 Outputs
7	PIC (SPI)
8	SPI

Note: The Selector Position must be changed to Position 6 to select DIGIO -8 Ch.Dig IN-/OUT Test by Default.

FIGURE 2-9: PDI SELECTOR HEX SWITCH ON THE BECKHOFF EL9800

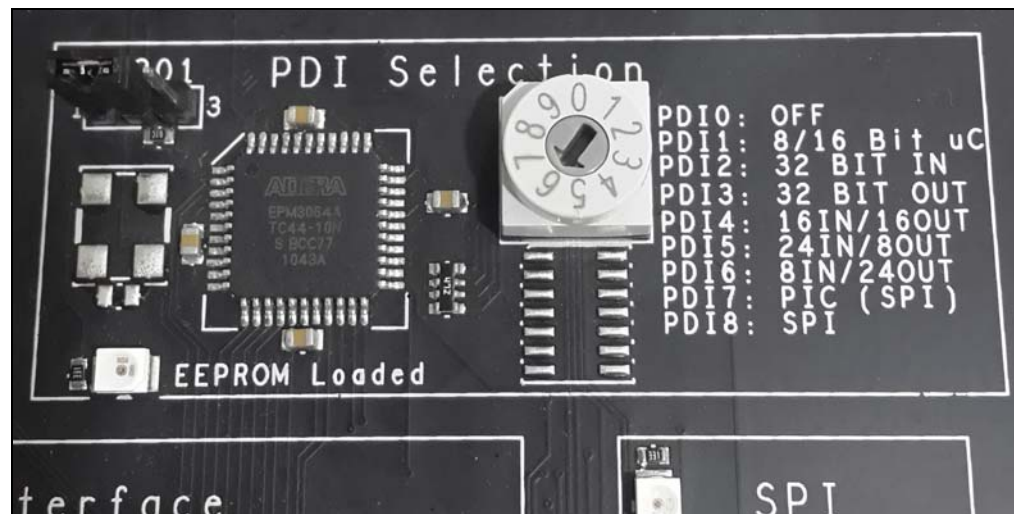

2.7 MECHANICALS

FIGURE 2-10: EVB-LAN9252-ADD-ON MECHANICAL DIMENSIONS

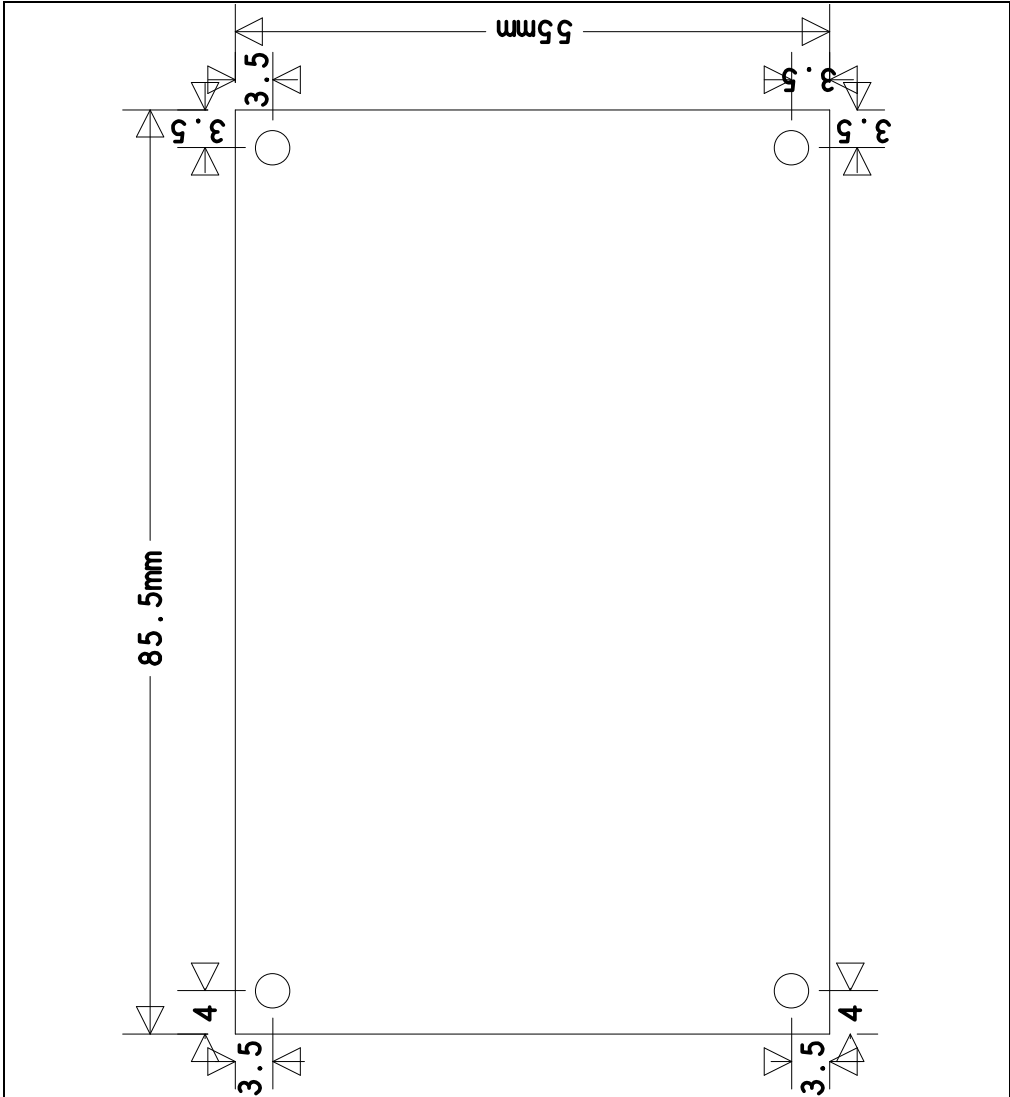

Appendix A. Evaluation Board Photo

A.1 INTRODUCTION

This appendix shows the EVB-LAN9252-ADD-ON Evaluation Board.

FIGURE A-1: EVB-LAN9252-ADD-ON EVALUATION BOARD

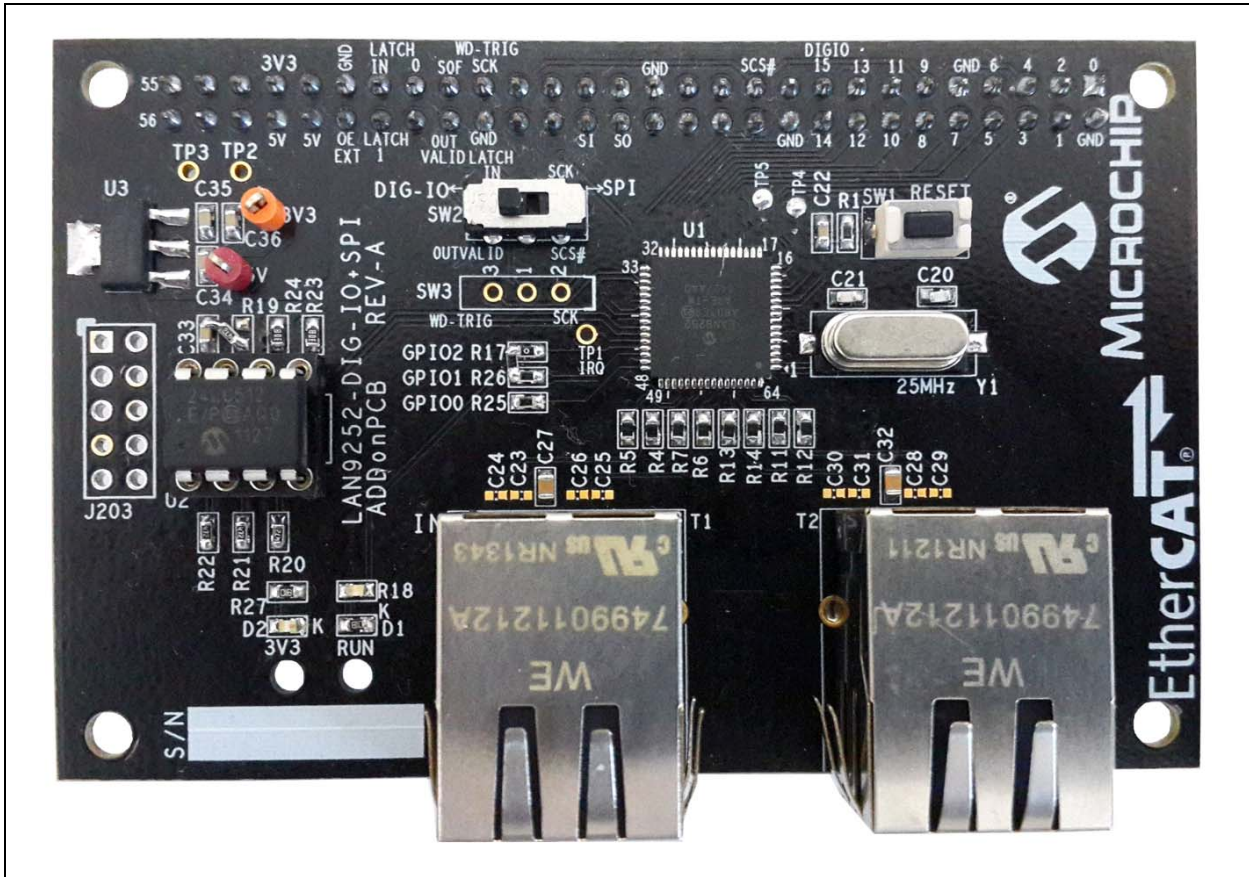

NOTES:



Appendix B. Evaluation Board Schematics

B.1 INTRODUCTION

This appendix shows the EVB-LAN9252-ADD-ON Evaluation Board Schematics.

FIGURE B-1: EVB-LAN9252-ADD-ON SCHEMATIC LAN9252

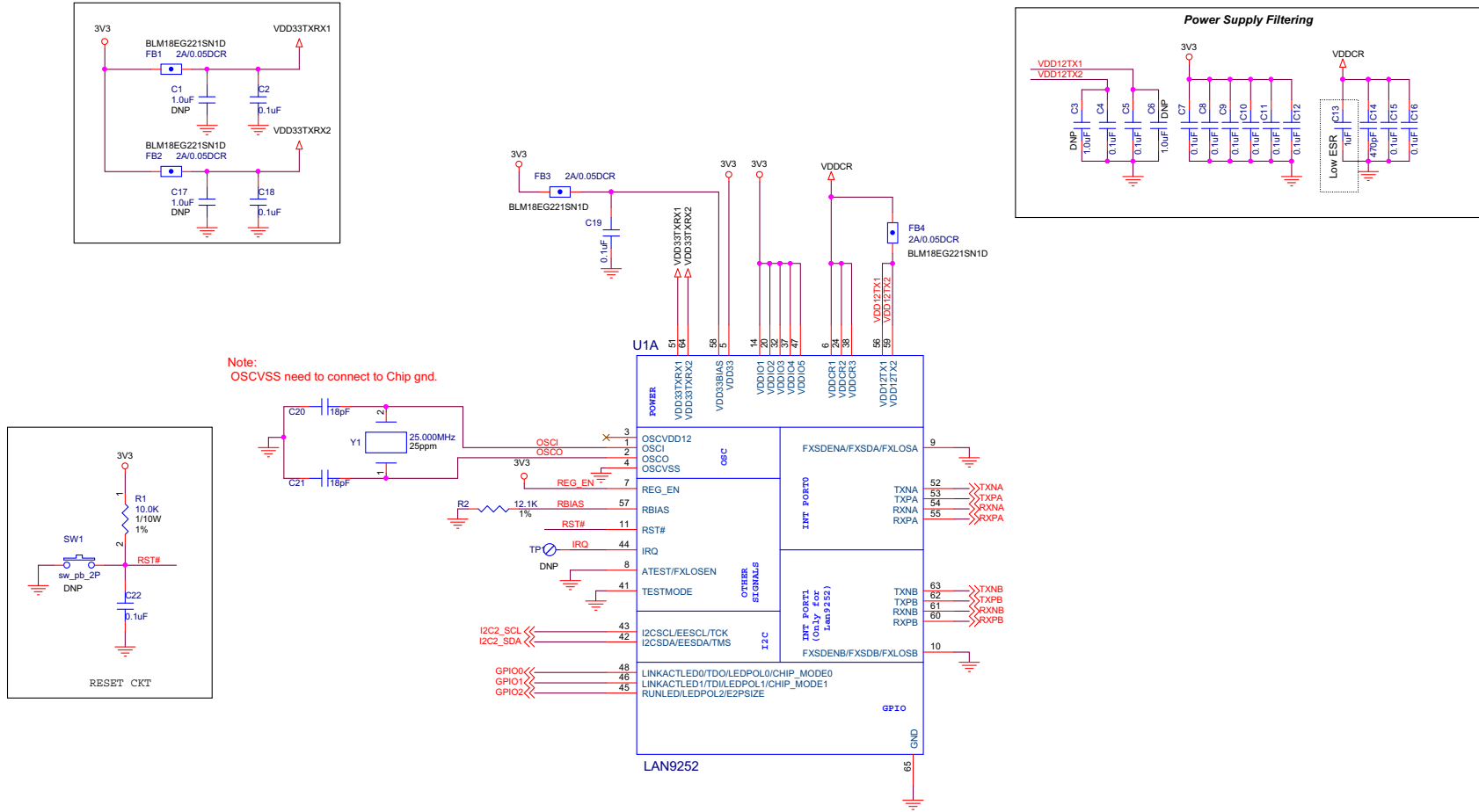

FIGURE B-2: EVB-LAN9252-ADD-ON SCHEMATIC COPPER MODE INTERFACE

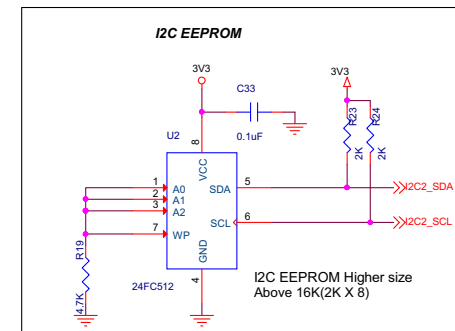
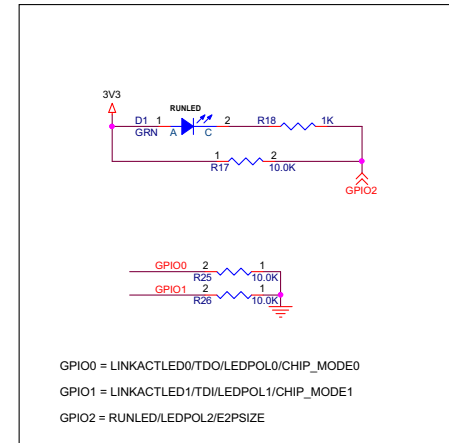
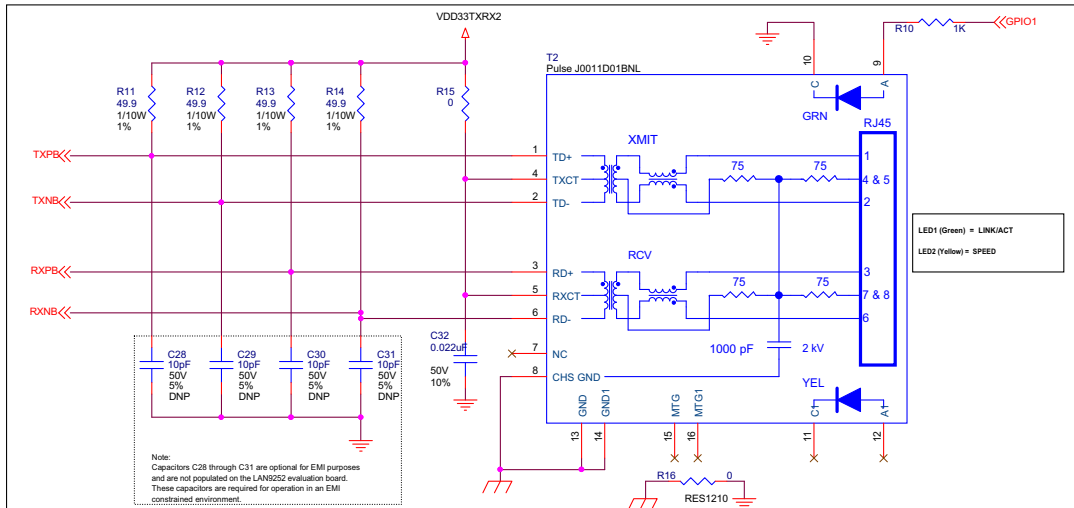
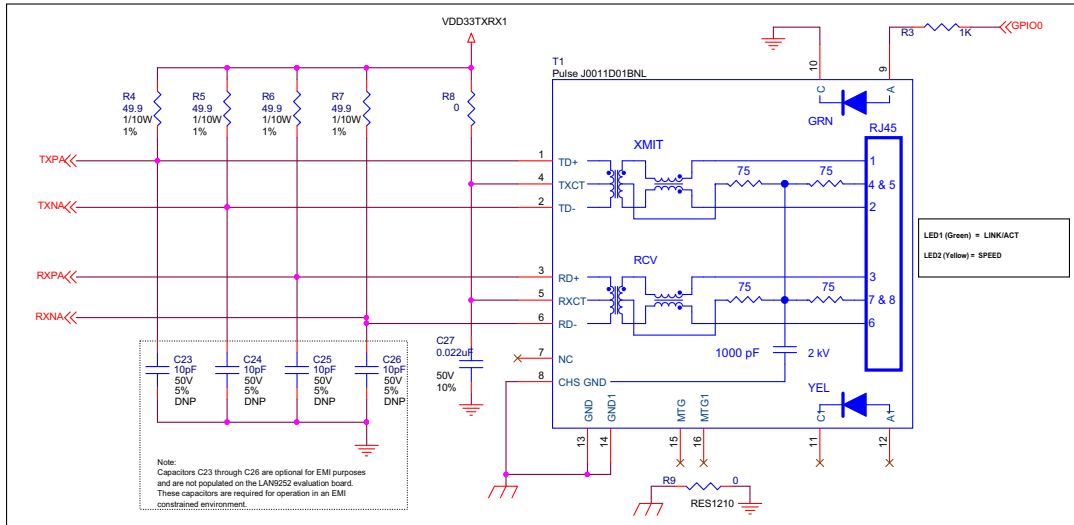
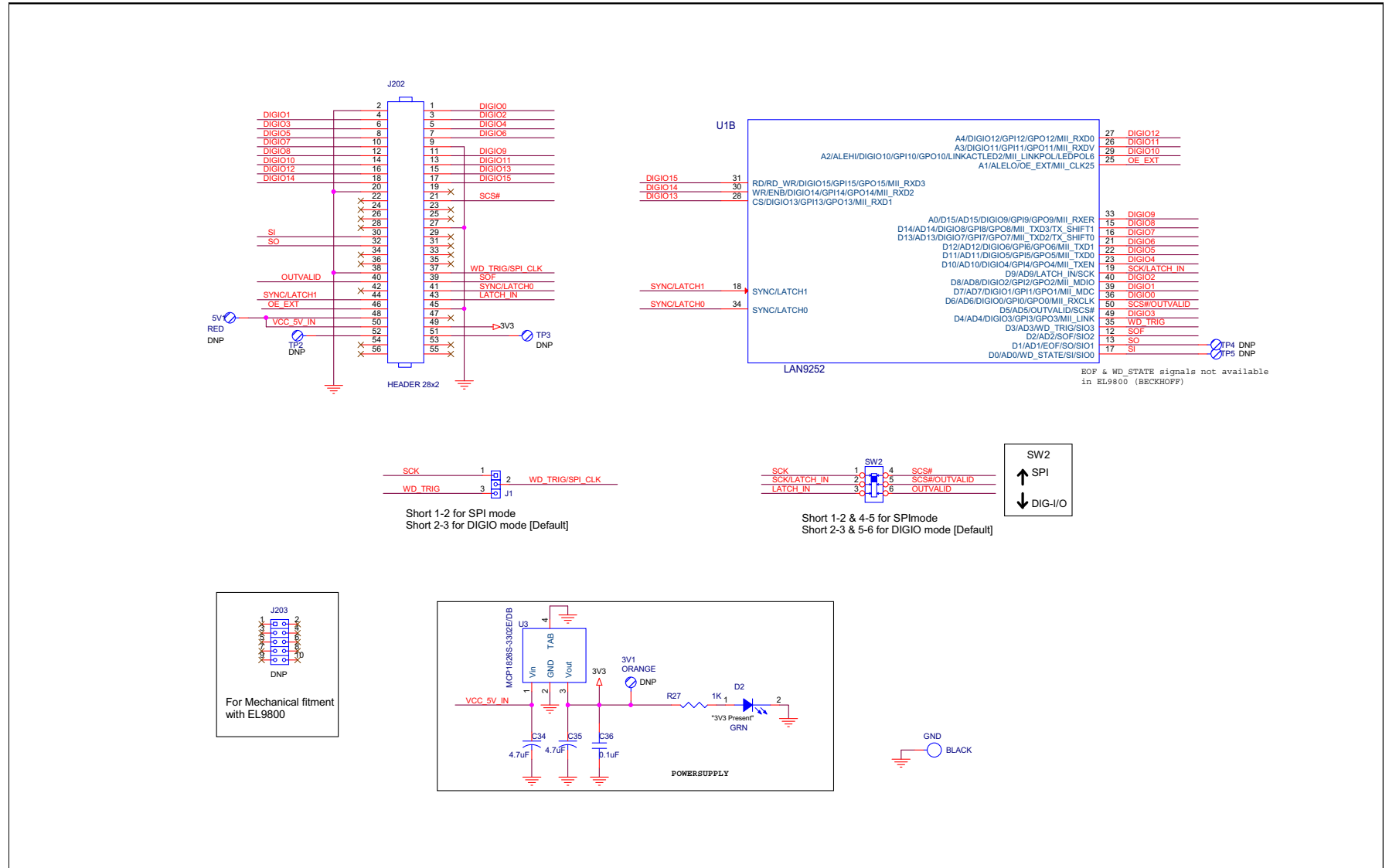

FIGURE B-3: EVB-LAN9252-ADD-ON SCHEMATIC BOARD-TO-BOARD INTERFACE





Appendix C. Bill of Materials (BOM)

C.1 INTRODUCTION

This appendix includes the EVB-LAN9252-ADD-ON Evaluation Board Bill of Materials (BOM).

TABLE C-1: EVB-LAN9292 ADD ON-BOM-REV-B BILL OF MATERIALS (BOM)

Item	Qty	Reference	Part	PCB Footprint	Vendor	Vendor P/N
2	16	C2,C4,C5,C7,C8,C9,C10,C11,C12,C15,C16,C18,C19,C22,C33,C36	0.1uF	CAP0603	Murata	GRM188R71E104KA01D
3	1	C13	1uF	CAP0603	Murata	GRM188R61C105KA93D
4	1	C14	470pF	CAP0603	Murata	GRM188R61C105KA93D
5	2	C20,C21	18pF	CAP0603	Murata	GRM033R71E471KA01D
7	2	C27,C32	0.022uF	CAP0603	Murata	GRM1885C1H180JA01D
8	2	C34,C35	4.7uF	CAP0603	Kemet	C0603C223K5RACTU
9	2	D1,D2	GRN	LED0603	Murata	GRM188R60J475KE19D
10	4	FB1,FB2,FB3,FB4	2A/0.05DCR	RES0603	Würth electronics	150 060 GS7 500 0
12	1	J1	HDR_1x3	TH_CONN_1X3P	Murata	BLM18EG221SN1D
13	1	J202	HEADER 28x2	th_conn_2x28p_F	Sullins Connector Solutions	PPTC282LFBN-RC
15	4	R1,R17,R25,R26	10.0K	RES0603	Panasonic	ERJ-3EKF1002V
16	1	R2	12.1K	RES0603	Rohm	MCR03ERTF1212
17	4	R3,R10,R18,R27	1K	RES0603	Panasonic	ERJ-3GEYJ102V
18	8	R4,R5,R6,R7,R11,R12,R13,R14	49.9	RES0603	Yageo	RC0603FR-0749R9L
19	2	R8,R15	0	RES0603	Panasonic	ERJ-3GEY0R00V
20	2	R9,R16	0	RES1210	Vishay	CRCW12100000Z0EA
21	1	R19	4.7K	RES0603	Panasonic	ERJ-3EKF4701V
22	2	R23,R24	2K	RES0603	Panasonic	ERJ-3GEYJ202V
24	1	SW2	JS202011CQN	TH_SW_DPD2_6P	Panasonic	JS202011CQN
26	2	T1,T2	Pulse - J0011D01BNL	th_conn_pulse_rj45_j0026	Pulse Electronics	J0011D01BNL
27	1	U1	LAN9252	IC_QFN64	Microchip	LAN5252
28	1	U2	24FC512	IC_SO8	Microchip	25FC512-I/SN
29	1	U3	MCP1826S-3302E/DB	SOT223	Microchip	MCP1826S-3302E/DB
30	1	Y1	25.000MHz	XTAL_HCM49	Cardinal Components Inc.	CSM1Z-A5B2C5-40-25.0D18-F

TABLE C-2: EVB-LAN9292 ADD ON-BOM-REV-B DO NOT POPULATE (DNP) COMPONENTS

Item	Qty	Reference	Part	PCB Footprint
1	4	C1,C3,C6,C17	1.0uF	CAP0603
6	8	C23,C24,C25,C26,C28,C29,C30,C31	10pF	CAP0402
11	1	GND	BLACK	TH_TP_60D40
14	1	J203	2x5	TH_CONN_2X5P
23	1	SW1	EVQ-PJU04K	sw_pb_2P
25	5	TP1,TP2,TP3,TP4,TP5	BergStick	TH_TP_60D40
31	1	3V1	ORANGE	TH_TP_60D40
32	1	5V1	RED	TH_TP_60D40



MICROCHIP

Worldwide Sales and Service

AMERICAS

Corporate Office
2355 West Chandler Blvd.
Chandler, AZ 85224-6199
Tel: 480-792-7200
Fax: 480-792-7277
Technical Support:
<http://www.microchip.com/support>
Web Address:
www.microchip.com

Atlanta
Duluth, GA
Tel: 678-957-9614
Fax: 678-957-1455

Austin, TX
Tel: 512-257-3370

Boston
Westborough, MA
Tel: 774-760-0087
Fax: 774-760-0088

Chicago
Itasca, IL
Tel: 630-285-0071
Fax: 630-285-0075

Cleveland
Independence, OH
Tel: 216-447-0464
Fax: 216-447-0643

Dallas
Addison, TX
Tel: 972-818-7423
Fax: 972-818-2924

Detroit
Novi, MI
Tel: 248-848-4000

Houston, TX
Tel: 281-894-5983

Indianapolis
Noblesville, IN
Tel: 317-773-8323
Fax: 317-773-5453

Los Angeles
Mission Viejo, CA
Tel: 949-462-9523
Fax: 949-462-9608

New York, NY
Tel: 631-435-6000

San Jose, CA
Tel: 408-735-9110

Canada - Toronto
Tel: 905-673-0699
Fax: 905-673-6509

ASIA/PACIFIC

Asia Pacific Office
Suites 3707-14, 37th Floor
Tower 6, The Gateway
Harbour City, Kowloon

Hong Kong
Tel: 852-2943-5100
Fax: 852-2401-3431

Australia - Sydney
Tel: 61-2-9868-6733
Fax: 61-2-9868-6755

China - Beijing
Tel: 86-10-8569-7000
Fax: 86-10-8528-2104

China - Chengdu
Tel: 86-28-8665-5511
Fax: 86-28-8665-7889

China - Chongqing
Tel: 86-23-8980-9588
Fax: 86-23-8980-9500

China - Dongguan
Tel: 86-769-8702-9880

China - Hangzhou
Tel: 86-571-8792-8115
Fax: 86-571-8792-8116

China - Hong Kong SAR
Tel: 852-2943-5100
Fax: 852-2401-3431

China - Nanjing
Tel: 86-25-8473-2460
Fax: 86-25-8473-2470

China - Qingdao
Tel: 86-532-8502-7355
Fax: 86-532-8502-7205

China - Shanghai
Tel: 86-21-5407-5533
Fax: 86-21-5407-5066

China - Shenyang
Tel: 86-24-2334-2829
Fax: 86-24-2334-2393

China - Shenzhen
Tel: 86-755-8864-2200
Fax: 86-755-8203-1760

China - Wuhan
Tel: 86-27-5980-5300
Fax: 86-27-5980-5118

China - Xian
Tel: 86-29-8833-7252
Fax: 86-29-8833-7256

ASIA/PACIFIC

China - Xiamen
Tel: 86-592-2388138
Fax: 86-592-2388130

China - Zhuhai
Tel: 86-756-3210040
Fax: 86-756-3210049

India - Bangalore
Tel: 91-80-3090-4444
Fax: 91-80-3090-4123

India - New Delhi
Tel: 91-11-4160-8631
Fax: 91-11-4160-8632

India - Pune
Tel: 91-20-3019-1500

Japan - Osaka
Tel: 81-6-6152-7160
Fax: 81-6-6152-9310

Japan - Tokyo
Tel: 81-3-6880-3770
Fax: 81-3-6880-3771

Korea - Daegu
Tel: 82-53-744-4301
Fax: 82-53-744-4302

Korea - Seoul
Tel: 82-2-554-7200
Fax: 82-2-558-5932 or
82-2-558-5934

Malaysia - Kuala Lumpur
Tel: 60-3-6201-9857
Fax: 60-3-6201-9859

Malaysia - Penang
Tel: 60-4-227-8870
Fax: 60-4-227-4068

Philippines - Manila
Tel: 63-2-634-9065
Fax: 63-2-634-9069

Singapore
Tel: 65-6334-8870
Fax: 65-6334-8850

Taiwan - Hsin Chu
Tel: 886-3-5778-366
Fax: 886-3-5770-955

Taiwan - Kaohsiung
Tel: 886-7-213-7828

Taiwan - Taipei
Tel: 886-2-2508-8600
Fax: 886-2-2508-0102

Thailand - Bangkok
Tel: 66-2-694-1351
Fax: 66-2-694-1350

EUROPE

Austria - Wels
Tel: 43-7242-2244-39
Fax: 43-7242-2244-393

Denmark - Copenhagen
Tel: 45-4450-2828
Fax: 45-4485-2829

France - Paris
Tel: 33-1-69-53-63-20
Fax: 33-1-69-30-90-79

Germany - Dusseldorf
Tel: 49-2129-3766400

Germany - Karlsruhe
Tel: 49-721-625370

Germany - Munich
Tel: 49-89-627-144-0
Fax: 49-89-627-144-44

Italy - Milan
Tel: 39-0331-742611
Fax: 39-0331-466781

Italy - Venice
Tel: 39-049-7625286

Netherlands - Drunen
Tel: 31-416-690399
Fax: 31-416-690340

Poland - Warsaw
Tel: 48-22-3325737

Spain - Madrid
Tel: 34-91-708-08-90
Fax: 34-91-708-08-91

Sweden - Stockholm
Tel: 46-8-5090-4654

UK - Wokingham
Tel: 44-118-921-5800
Fax: 44-118-921-5820

07/14/15

Mouser Electronics

Authorized Distributor

Click to View Pricing, Inventory, Delivery & Lifecycle Information:

[Microchip:](#)

[EVB-LAN9252-ADD-ON](#)



Компания «ЭлектроПласт» предлагает заключение долгосрочных отношений при поставках импортных электронных компонентов на взаимовыгодных условиях!

Наши преимущества:

- Оперативные поставки широкого спектра электронных компонентов отечественного и импортного производства напрямую от производителей и с крупнейших мировых складов;
- Поставка более 17-ти миллионов наименований электронных компонентов;
- Поставка сложных, дефицитных, либо снятых с производства позиций;
- Оперативные сроки поставки под заказ (от 5 рабочих дней);
- Экспресс доставка в любую точку России;
- Техническая поддержка проекта, помощь в подборе аналогов, поставка прототипов;
- Система менеджмента качества сертифицирована по Международному стандарту ISO 9001;
- Лицензия ФСБ на осуществление работ с использованием сведений, составляющих государственную тайну;
- Поставка специализированных компонентов (Xilinx, Altera, Analog Devices, Intersil, Interpoint, Microsemi, Aeroflex, Peregrine, Syfer, Eurofarad, Texas Instrument, Miteq, Cobham, E2V, MA-COM, Hittite, Mini-Circuits, General Dynamics и др.);

Помимо этого, одним из направлений компании «ЭлектроПласт» является направление «Источники питания». Мы предлагаем Вам помощь Конструкторского отдела:

- Подбор оптимального решения, техническое обоснование при выборе компонента;
- Подбор аналогов;
- Консультации по применению компонента;
- Поставка образцов и прототипов;
- Техническая поддержка проекта;
- Защита от снятия компонента с производства.



Как с нами связаться

Телефон: 8 (812) 309 58 32 (многоканальный)

Факс: 8 (812) 320-02-42

Электронная почта: org@eplast1.ru

Адрес: 198099, г. Санкт-Петербург, ул. Калинина, дом 2, корпус 4, литера А.