

Trailing edge phase control rotary wall dimmer based on the STF17N62K3 power MOSFET

Data brief



Features

- Operation for 2-wire wall dimmer
- Trailing-edge control only (compatible with all lamps commonly found on the market)
- Operation on 110 V or 230 V rms line voltage ($\pm 10\%$) and 50 Hz or 60 Hz line frequency;
- Dimmable power range (without heatsinks mounted on MOSFETs)
 - 40 W to 300 W for 230 V rms line
 - 15 W to 90 W for 110 V rms line
- Maximum operating ambient temperature: 50 °C
- Power efficiency @ Max power - 230 V > 95%
- Power factor @ Max power > 0.98
- Control and regulation interface with a switched type single linear rotary potentiometer
- Compliance with EMC standards:
 - IEC 61000-4-5: criteria A for 2 kV surge
 - Compliant with EN55015 with 300 W - 230 V halogen lamp
- Flicker-free dimming performance

- Smooth dimming operation and silent dimming control with no buzzing or audible noise
- Acceptable levels of EMI noise without the need for LC filters to reduce conducted emission disturbances
- Low inrush current generation
- RoHS compliant

Description

The STEVAL-ILD005V1 evaluation board implements a simple and cost-effective MOS-based reverse phase cut dimming solution for analog wall dimmers using a pair of STF17N62K3 power MOSFETs controlled by a triple 3-input NOR gate to effectively dim either resistive or capacitive lighting loads (i.e. halogen lamps, electronic low voltage transformers and various dimmable CFL/LED lamps). The AC analog control dimming technique employed allows for both on/off power switching and up/down dimming functions through a single linear rotary potentiometer equipped with a mechanical switch which opens the circuit at minimum setting. Control of the board is achieved using a triple 3-input NOR gate (pin-to-pin compatible with a ST's HCF4025BE 14-lead dual in-line CMOS gate logic device in plastic SO-14 micropackage) which acts as a gate driving voltage signal source, performs zero crossing detection and timing through the use of a few other passive components and diodes.

1 Schematic diagram

Figure 1: STEVAL-ILD005V1 circuit schematic

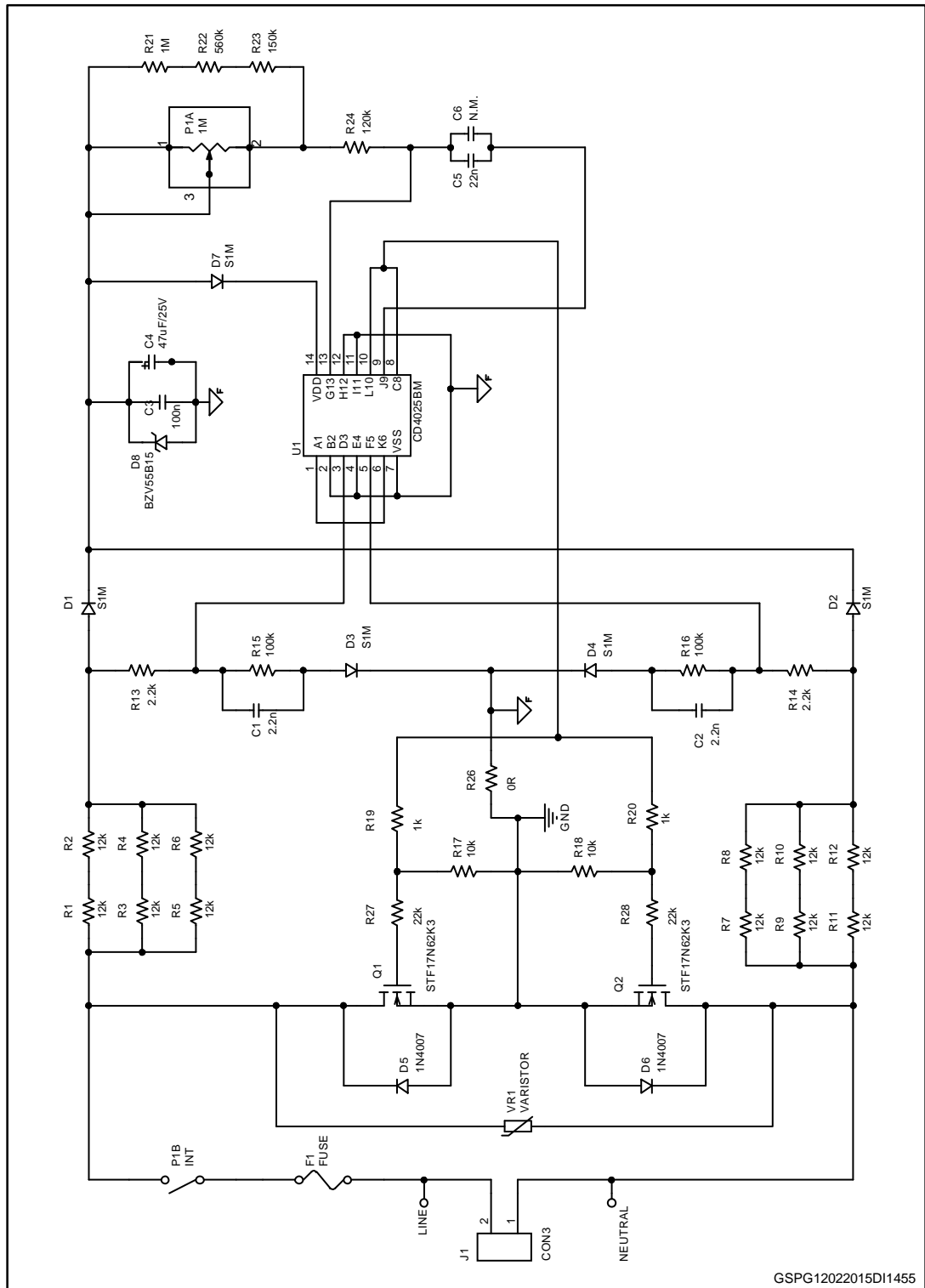

GSPG12022015DI1455

2 Revision history

Table 1: Document revision history

Date	Rev	Changes
12-Feb-2015	1	First release.
18-Feb-2015	2	Minor text change to improve readability
23-Apr-2015	3	Updated: Features

IMPORTANT NOTICE – PLEASE READ CAREFULLY

STMicroelectronics NV and its subsidiaries ("ST") reserve the right to make changes, corrections, enhancements, modifications, and improvements to ST products and/or to this document at any time without notice. Purchasers should obtain the latest relevant information on ST products before placing orders. ST products are sold pursuant to ST's terms and conditions of sale in place at the time of order acknowledgement.

Purchasers are solely responsible for the choice, selection, and use of ST products and ST assumes no liability for application assistance or the design of Purchasers' products.

No license, express or implied, to any intellectual property right is granted by ST herein.

Resale of ST products with provisions different from the information set forth herein shall void any warranty granted by ST for such product.

ST and the ST logo are trademarks of ST. All other product or service names are the property of their respective owners.

Information in this document supersedes and replaces information previously supplied in any prior versions of this document.

© 2015 STMicroelectronics – All rights reserved



Компания «ЭлектроПласт» предлагает заключение долгосрочных отношений при поставках импортных электронных компонентов на взаимовыгодных условиях!

Наши преимущества:

- Оперативные поставки широкого спектра электронных компонентов отечественного и импортного производства напрямую от производителей и с крупнейших мировых складов;
- Поставка более 17-ти миллионов наименований электронных компонентов;
- Поставка сложных, дефицитных, либо снятых с производства позиций;
- Оперативные сроки поставки под заказ (от 5 рабочих дней);
- Экспресс доставка в любую точку России;
- Техническая поддержка проекта, помощь в подборе аналогов, поставка прототипов;
- Система менеджмента качества сертифицирована по Международному стандарту ISO 9001;
- Лицензия ФСБ на осуществление работ с использованием сведений, составляющих государственную тайну;
- Поставка специализированных компонентов (Xilinx, Altera, Analog Devices, Intersil, Interpoint, Microsemi, Aeroflex, Peregrine, Syfer, Eurofarad, Texas Instrument, Miteq, Cobham, E2V, MA-COM, Hittite, Mini-Circuits, General Dynamics и др.);

Помимо этого, одним из направлений компании «ЭлектроПласт» является направление «Источники питания». Мы предлагаем Вам помощь Конструкторского отдела:

- Подбор оптимального решения, техническое обоснование при выборе компонента;
- Подбор аналогов;
- Консультации по применению компонента;
- Поставка образцов и прототипов;
- Техническая поддержка проекта;
- Защита от снятия компонента с производства.



Как с нами связаться

Телефон: 8 (812) 309 58 32 (многоканальный)

Факс: 8 (812) 320-02-42

Электронная почта: org@eplast1.ru

Адрес: 198099, г. Санкт-Петербург, ул. Калинина, дом 2, корпус 4, литера А.