

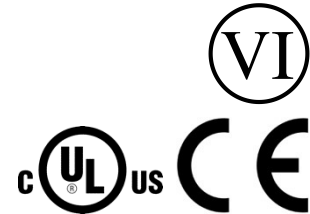

30W, IEEE802.3at Single Port PoE Active Injectors



X

Features

- IEEE802.3at Complaint
- DOE VI Efficiency
- EU CoC Version 5 Tier 2 Efficiency
- Compact Size
- Limited Power Source
- Three Wire Input Models
- Full Over-Voltage and Over-Current Protection
- Non-Vented Case
- 1 Year Warranty

Applications

- IP Telephones
- Wireless Access Points
- Bluetooth® Access Points
- Security Cameras
- IP Print Servers
- WiMAX® Access Points

Safety Approvals

- cUL/UL (62368-1)
- CB (IEC62368-1)
- CE
- UL,cUL, CB 60950-X

Mechanical Characteristics

- Length: 126mm (4.96in.)
- Width: 45.5mm (1.79in.)
- Height: 30mm (1.18in.)
- Weight: 0.16kg (5.64oz)

Output Specifications

Model	Data Speed	DC Output Voltage	Load		Regulation ¹	
			Min.	Max.	Line	Load
POEA30U-1AT-R ²	1G	56V	10mA	536mA	54-57V	
POEA30U-1ATE-R	1G	56V	10mA	536mA	54-57V	
POEA30U-1AT-2-R	2.5G	56V	10mA	536mA	54-57V	
POEA30U-1AT-5-R	5G	56V	10mA	536mA	54-57V	
POEA30U-1AT-X-R	10G	56V	10mA	536mA	54-57V	

Notes:

1. Voltage measured within 2" of the output RJ45 connector on data pairs 3,6(+) and 1,2(-)
2. Unshielded RJ45 jacks

Phihong is not responsible for any error, and reserves the right to make changes without notice. Please visit our website at www.phihong.com for the most up-to-date specifications and contact information.

INPUT:**AC Input Voltage Range**

90 to 264VAC

AC Input Current

0.8A (RMS) max

AC Input Frequency

47Hz to 63Hz

Leakage Current

3.5mA max @254V, 50Hz

Max In-rush Current60A max at 240VAC and max load
(Cold Start at ambient 25°C)**OUTPUT:****Output Power**

30W, de-rated up to 15W at 50°C

Hold up Time

10mSec min at max load at 120VAC, 60Hz

Efficiency

Minimum 85% @max load

ENVIRONMENTAL**Temperature**

Operating -10°C to +40°C

Non-operating -20°C to +70°C

Relative Humidity 5 to 90%

EMI

EN55032 Class B, FCC part 15 Class B

EMC

ESD: IEC61000-4-2 , Level 3

RS: IEC61000-4-3, Level 3

EFT/Burst: IEC61000-4-4, Level 2

Surge: IEC61000-4-5, Level 3

CS: IEC61000-4-6 , Level 3

Voltage Dips: IEC61000-4-11, Class 3

Harmonic: IEC61000-3-2, Class A

Isolation (HI-POT)

4242VDC for 1 minute, 10mA

Insulation Resistance

Primary to secondary:>10M Ohm 500VDC

FEATURES:**Over Voltage Protection**

Non-Latching auto recovery

Over Current Protection

<750mA Non-latch

Short Circuit Protection

Non-Latching auto recovery. Output can be shorted permanently without damage.

LED Indicators

Green LED Slow Blinking – No connection

Green LED Fast Blinking – No Load

Green Solid – Power Good

Green/Yellow Fast Blink – Fault Detected

Yellow Solid with Green Blink – Over/Short Current Detected

AC Input Connector

IEC320 C14 -

Output Connection

56VDC RJ45 Pins 3&6

56VRTN RJ45 Pins 1&2

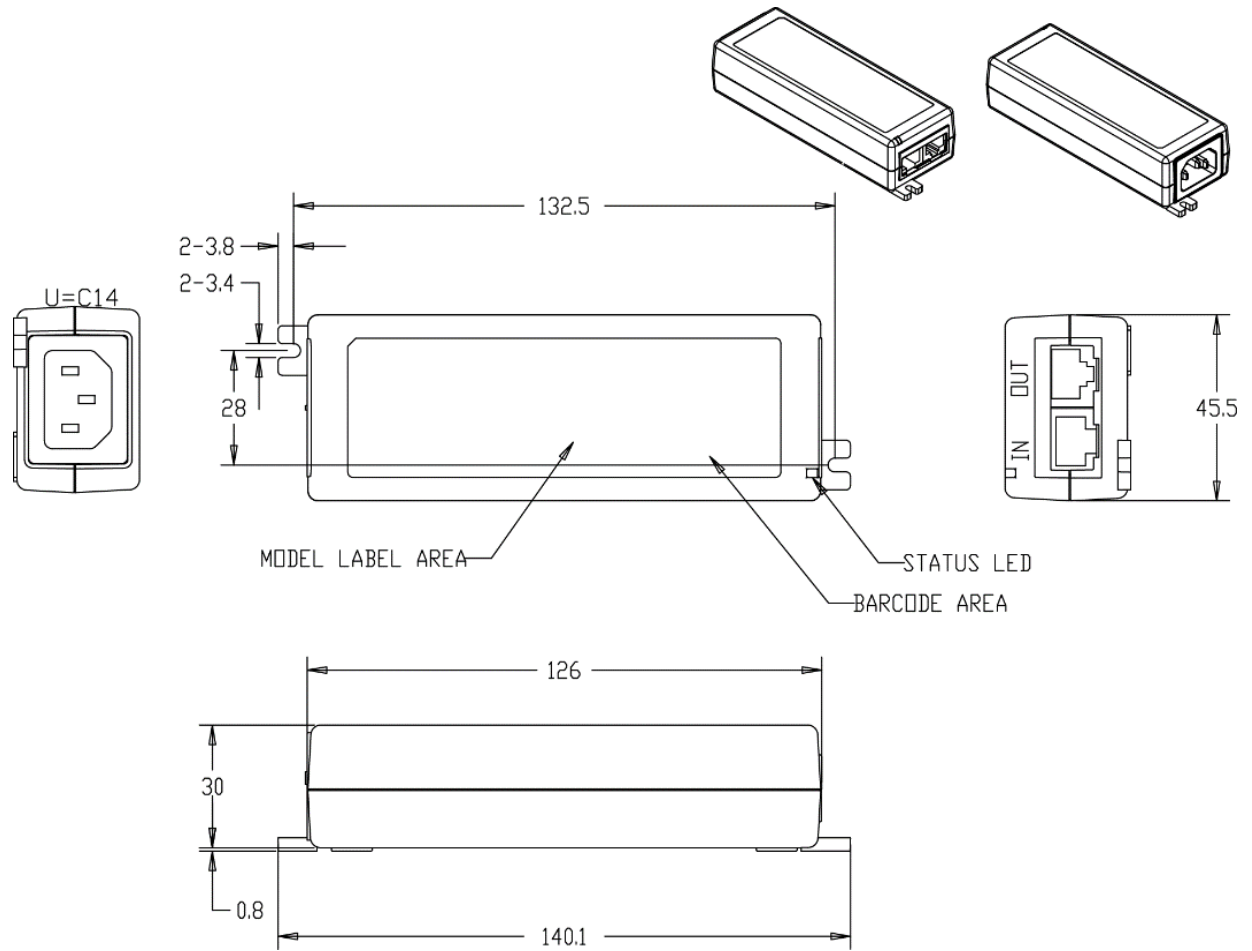

Supplier's Declaration of Conformity
47 CFR § 2.1077 Compliance Information

Phihong USA Corporation
47800 Fremont Boulevard
Fremont, CA 94538
Telephone: (510) 445-0100
www.phihong.com

NOTE: This model has/The models in this products series have been tested and found to comply with the limits for a Class B digital device, pursuant to part 15 of the FCC Rules. These limits are designed to provide reasonable protection against harmful interference in a residential installation. This equipment generates, uses and can radiate radio frequency energy and, if not installed and used in accordance with the instructions, may cause harmful interference to radio communications. However, there is no guarantee that interference will not occur in a particular installation. If this equipment does cause harmful interference to radio or television reception, which can be determined by turning the equipment off and on, the user is encouraged to try to correct the interference by one or more of the following measures:

- Reorient or relocate the receiving antenna.
- Increase the separation between the equipment and receiver.
- Connect the equipment into an outlet on a circuit different from that to which the receiver is connected.
- Consult the dealer or an experienced radio/TV technician for help.

Changes or modifications to equipment not expressly approved by PHIHONG could void the user's authority to operate the equipment.



Компания «ЭлектроПласт» предлагает заключение долгосрочных отношений при поставках импортных электронных компонентов на взаимовыгодных условиях!

Наши преимущества:

- Оперативные поставки широкого спектра электронных компонентов отечественного и импортного производства напрямую от производителей и с крупнейших мировых складов;
- Поставка более 17-ти миллионов наименований электронных компонентов;
- Поставка сложных, дефицитных, либо снятых с производства позиций;
- Оперативные сроки поставки под заказ (от 5 рабочих дней);
- Экспресс доставка в любую точку России;
- Техническая поддержка проекта, помощь в подборе аналогов, поставка прототипов;
- Система менеджмента качества сертифицирована по Международному стандарту ISO 9001;
- Лицензия ФСБ на осуществление работ с использованием сведений, составляющих государственную тайну;
- Поставка специализированных компонентов (Xilinx, Altera, Analog Devices, Intersil, Interpoint, Microsemi, Aeroflex, Peregrine, Syfer, Eurofarad, Texas Instrument, Miteq, Cobham, E2V, MA-COM, Hittite, Mini-Circuits, General Dynamics и др.);

Помимо этого, одним из направлений компании «ЭлектроПласт» является направление «Источники питания». Мы предлагаем Вам помощь Конструкторского отдела:

- Подбор оптимального решения, техническое обоснование при выборе компонента;
- Подбор аналогов;
- Консультации по применению компонента;
- Поставка образцов и прототипов;
- Техническая поддержка проекта;
- Защита от снятия компонента с производства.



Как с нами связаться

Телефон: 8 (812) 309 58 32 (многоканальный)

Факс: 8 (812) 320-02-42

Электронная почта: org@eplast1.ru

Адрес: 198099, г. Санкт-Петербург, ул. Калинина, дом 2, корпус 4, литера А.