



Dura-Con™

Dura-Con™ Hermetic Connectors

Standard Connectors With
High Performance Hermetic Seals Catalog



belfuse.com/cinch

Cinch Dura-Con™ Hermetic Connectors offers a high performance hermetic seal designed into our standard Dura-Con™ Connector

Features

- Both Plug and Socket available in 9, 15, 21, 25, 31, 37 and 51 positions
- Aluminium shell provides extra strength and EMI/RFI shielding capability
- Rugged twist-pin contacts resistant to shock and vibration make metal shell Dura-Con™ an excellent choice for harsh environments
- Hermetic seal achieved through Cinch Hermetic compound
- Tested to Mil-DTL-83513
- Pigtail and Solder Cup variations only

Electrical

- Current Rating: 3 Amps maximum
- Withstanding Voltage: 600 VAC RMS @ sea level
- Contact Resistance: 8 milliohms maximum

Materials

- Insulator: UL94V-0 rated glass-filled polyester or diallyl phthalate
- Contacts: Pins - Copper alloy, sockets - Copper alloy (machined)
- Contact Plating: 1.27 micron gold as per Mil-G-4204
- Shell: Aluminium alloy
- Shell Plating: Electroless nickel and cadmium
- Hermetic Seal: Cinch Hermetic compound
- Sealing: Fluoro Silicone 'O' ring seal

Environmental

- Operating Temperature: -55°C to +125°C
- Hermetic Seal: 1 x 10⁻⁸cc/sec @ 1 Atmosphere Helium

Mechanical

- Individual Contact: 6 oz. (170.40g) maximum insertion force 0.5 oz. (14.20g) minimum withdrawal

Connector Performance Specifications

Property	Requirement	Test Method
Current Rating	3 Amp maximum	
Dielectric Withstanding Voltage Sea level	900 VAC	Mil-STD-1344, Method 3001
Contact Resistance	8 milliohms maximum	Mil-STD-202, Method 307
Low Level Contact resistance	32 milliohms maximum	Mil-STD-1344, Method 3002
Insulation Resistance	5000 megohms minimum	Mil-STD-1344, Method 3003
Magnetic Permeability	2.0 μmaximum	ASTM A342
Mating Force	(10 ounces max.) x (# of contacts)	Mil-DTL-83513
Unmating Force	0.5 ounces min.) x (# of contacts)	Mil-DTL-83513
Contact Retention	5 pounds minimum	Mil-STD-1344, Method 2007
Operating Temperature	-55°C. to 125°C.	
Durability	500 mating cycles minimum	Mil-DTL-83515, Para 4.5.16
Salt Spray (corrosion)	48 hours	Mil-DTL-1344, Method 2004, Condition E
Crimp Tensile Strength		Mil-DTL-83513, Para 4.5.20
Wire Type M22759/11	5 pounds minimum	
Wire Type M22759/33	10 pounds minimum	
Shock	50 G's	Mil-STD-1344, Method 2004, Condition E
Vibration	20 G's	Mil-STD-1344, Method 2005, Condition IV
Minimum Hermetic Leakage Rate	1 x 10 ⁻⁸ mbar 1/s	
Moisture Permeation	0.5% in 168 hrs	

Mating Unmating Force

No. of Contacts	9	15	21	25	31	37	51	100
Maximum Mating Force	5.63 lbs	9.38 lbs	13.13 lbs	15.63 lbs	19.38 lbs	23.13 lbs	31.88 lbs	62.50 lbs
	2.56 kg	4.26 kg	5.96 kg	7.10 kg	8.80 kg	10.50 kg	14.47 kg	28.38 kg
Minimum Unmating Force	0.28 lbs	0.47 lbs	0.66 lbs	0.78 lbs	0.97 lbs	1.16 lbs	1.59 lbs	3.13 lbs
	0.13 kg	0.21 kg	0.30 kg	0.35 kg	0.44 kg	0.53 kg	0.72 kg	1.42 kg

DURA-CON™ METAL SHELL

Connector Dimensions - Mating view of pin insert. (Use reverse order for socket side)

Dura-Con™

Plug Arrangement

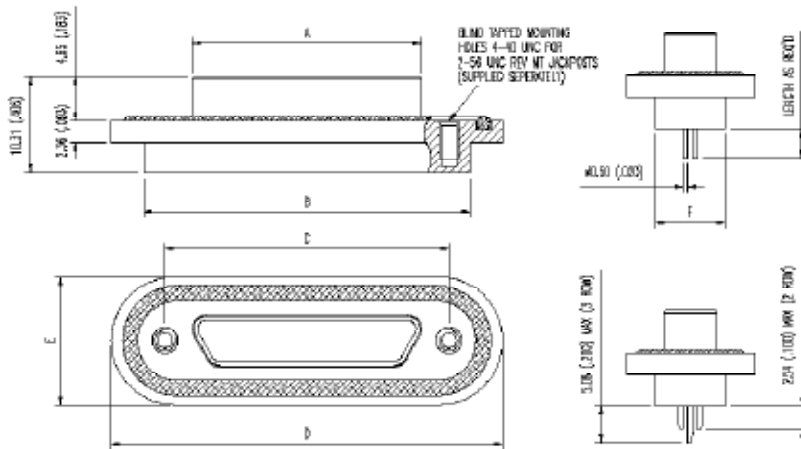

Socket Arrangement

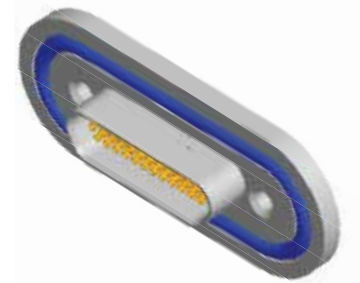
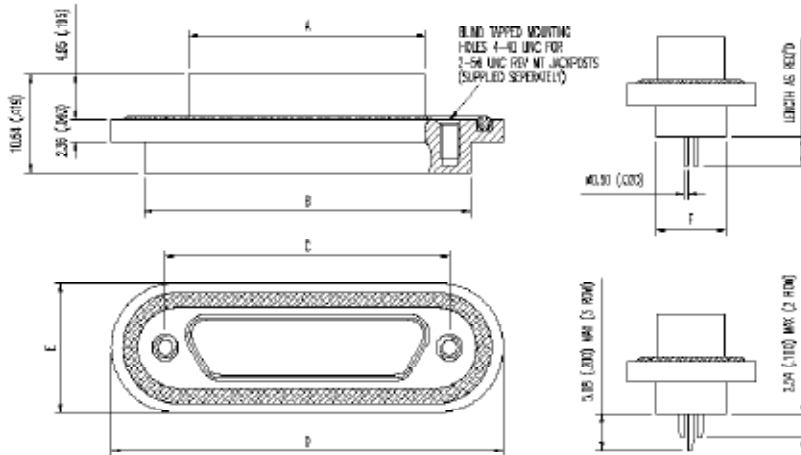

No. of Contacts	A Max.		± 0.25 (0.010")		± 0.127 (0.005")		± 0.20 (0.008")		± 0.20 (0.008")		± 0.20 (0.008")	
	mm	inches	mm	inches	mm	inches	mm	inches	mm	inches	mm	inches
9 Plug	8.4	0.333	19.65	0.774	14.35	0.565	31.68	1.247	17.00	0.670	7.50	0.295
9 Socket	10.06	0.396	19.65	0.774	14.35	0.565	31.68	1.247	17.00	0.670	7.50	0.295
15 Plug	12.27	0.483	23.45	0.923	18.16	0.715	34.16	1.345	17.00	0.670	7.50	0.295
15 Socket	13.87	0.546	23.45	0.923	18.16	0.715	34.16	1.345	17.00	0.670	7.50	0.295
21 Plug	16.08	0.633	27.25	1.073	21.97	0.865	39.15	1.541	17.00	0.670	7.50	0.295
21 Socket	17.68	0.696	27.25	1.073	21.97	0.865	39.15	1.541	17.00	0.670	7.50	0.295
25 Plug	18.62	0.733	29.85	1.175	24.51	0.965	41.66	1.640	17.00	0.670	7.50	0.295
25 Socket	20.22	0.796	29.85	1.175	24.51	0.965	41.66	1.640	17.00	0.670	7.50	0.295
31 Plug	21.16	0.883	33.65	1.325	28.32	1.115	44.13	1.737	17.00	0.670	7.50	0.295
31 Socket	24.03	0.946	33.65	1.325	28.32	1.115	44.13	1.737	17.00	0.670	7.50	0.295
37 Plug	26.24	1.033	37.45	1.474	32.13	1.265	49.12	1.934	17.00	0.670	7.50	0.295
37 Socket	27.84	1.096	37.45	1.474	32.13	1.265	49.12	1.934	17.00	0.670	7.50	0.295
51 Plug	24.97	0.983	36.15	1.423	30.86	1.215	48.50	1.909	18.10	0.713	8.60	0.339
51 Socket	26.57	1.046	36.15	1.423	30.86	1.215	48.50	1.909	18.10	0.713	8.60	0.339
100 Plug	Consult Cinch Connectors Ltd											
100 Socket	Consult Cinch Connectors Ltd											

DURA-CON™ MOUNTING HARDWARE

Mating view of pin insert. (Use reverse order for socket side) - 9 to 51 Way only

Dura-Con™

Recommended Torque Tightening

For tightening jackpost (4-40 UNC) into connector, 0.45 Nm / 0.55 Nm (4/5 in. lb)

Recommended torque for tightening jackscrew of mating connector (2-56 UNC) into jackpost, 0.23 Nm / 0.28 Nm (2/2.5 in. lb)

Jackpost Part Number	Panel Thickness		A		B	
	mm	inches	mm	inches	mm	inches
DN00008 08	0.8	0.031	0.65/0.60	0.026/0.024	4.6	0.181
DN00008 12	1.2	0.047	1.05/1.00	0.041/0.039	5.0	0.197
DN00008 16	1.6	0.063	1.45/1.40	0.057/0.055	5.4	0.213
DN00008 24	2.4	0.094	2.25/2.20	0.089/0.087	6.2	0.244

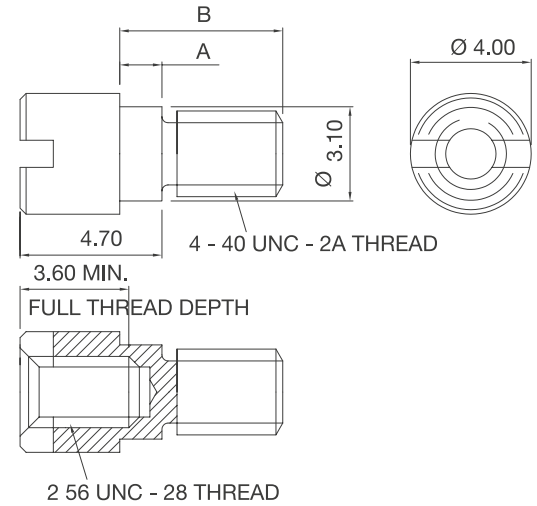

Panel Mounting Details

Jackpost Part Number	Panel Thickness. ±0.05 (.002)	
	mm	inches
DN00008 08	0.7	0.028
DN00008 12	1.1	0.043
DN00008 16	1.5	0.059
DN00008 24	2.3	0.091

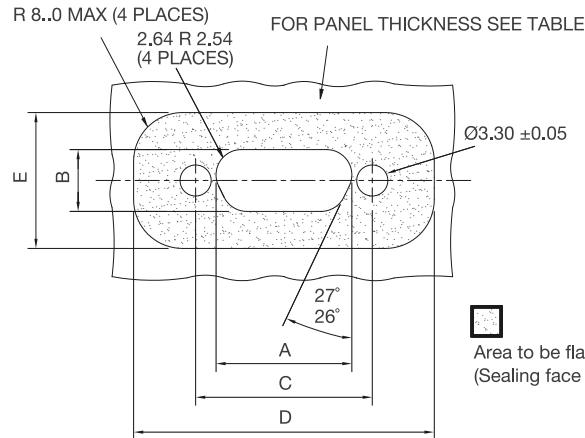

Area to be flat, smooth and free from tool marks, blemishes etc. (Sealing face for 'O' ring)

No. Ways	A + .10 (.004)		B + .10 (.004)		C ± 0.05 (.002)		D (MIN)		E (MIN)	
	mm	inches	mm	inches	mm	inches	mm	inches	mm	inches
9	10.11	0.398	6.32	0.249	14.35	0.565	35.0	1.378	20.0	0.787
15	13.92	0.548	6.32	0.249	18.16	0.715	37.0	1.457	20.0	0.787
21	17.73	0.698	6.32	0.249	21.97	0.865	42.0	1.654	20.0	0.787
25	20.27	0.798	6.32	0.249	24.51	0.965	45.0	1.772	20.0	0.787
31	24.08	0.948	6.32	0.249	28.34	1.116	47.0	1.850	20.0	0.787
37	27.89	1.098	6.32	0.249	32.13	1.265	52.0	2.047	20.0	0.787
51	26.62	1.048	7.42	0.292	30.86	1.215	52.0	2.047	22.0	0.866
100	Consult Cinch Connectors Ltd									

HOW TO ORDER

Mating view of pin insert. (Use reverse order for socket side)



Contact Arrangements

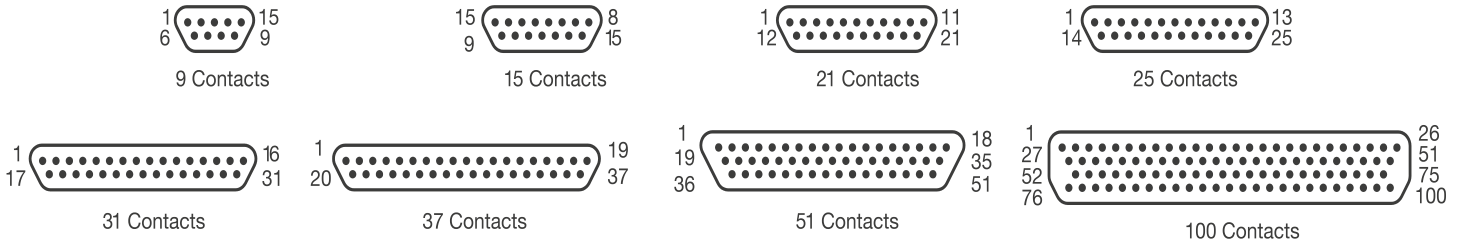

Ordering Information

DC D H 37 P 4 C 4-0.5 B N

Cinch Dura-Con D connector

Insulator type

D = Thermoplastic glass-reinforced

Mounting type

H = Hermetic

No. of contacts

9, 15, 21, 25, 31, 37, 51

Contact type

P = Pin (plug)

S = Socket (receptacle)

Wire size in AWG

4 = 24 AWG solid copper

S = Solder cup (skip to mounting hardware)

Wire type

C = Solid copper (uninsulated)

Shell plating

N = Electroless nickel

Mounting hardware**

B = No hardware

F = Float mount

R = Reverse float mount

K = Jackscrew (standard)

L = Jackscrew (low profile)

P = Jackpost, size 9 through 51

MIL-C-83513/5-07 size 100

MIL-C-83513/5-17

Lead length in inches***

00.5 Solid copper wire only

01.0 Solid copper wire only

02.0 Solid copper wire only

Insulation colour or wire finish

3 = Tin-plated

4 = Gold-plated (solid wire)

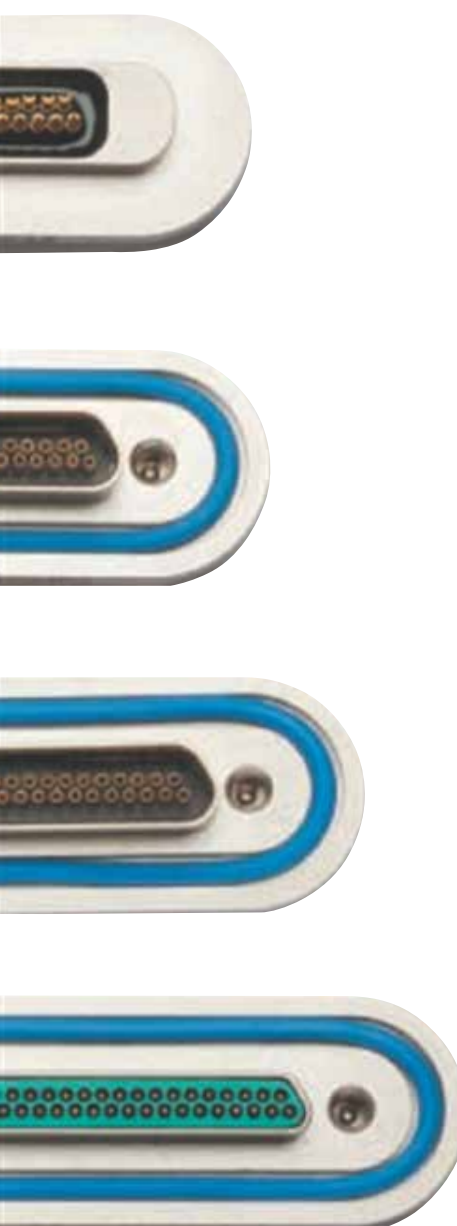

SECTOR

- Sea
- Aerospace
- Sub-Terrain
- Ground Support
- Armoured Vehicle
- Rail
- Space
- Radar
- Avionics
- Munitions / Missile

ENVIRONMENT

- Dust
- Moisture Resistant
- Full Water Immersion
- Chemical Compatibility RoHS
- Low Smoke / Zero Halogen
- Extreme Temperature
- Tolerance
- Flame Retardant

SPECIFICATION

- Operating Temperature
- Range
- Mating Cycles
- Electrical
- Voltage Rating
- Current Rating
- Filtration Rating
- Materials / Finish
- Contact Plating
- Housing Plating

CONNECTOR STYLE

- Rectangular
- Circular
- Z Axis Compression
- Power & Signal
- Hermetic
- IPC Rated
- Filtered
- Edge Connector
- Multipole
- High Speed
- Rugged Enclosure

MARKET SEGMENT

- Oil Petroleum Gas (OPG)
- Renewable Energy
- Military & Defence
- Commercial
- Computer
- Industrial
- Telecommunications
- Medical

WIRE TYPE

- Stranded
- Solid
- Twisted pairs
- Co-Axial
- Colour Code Single / Multi
- Multi Core
- Shielded
- Wire AWG
- Custom Cable

CONSTRUCTION

- Male
- Female
- Crimp
- Solder
- PC Tail
- 90°
- 180°
- RF Signals
- Number Contact Points
- Contact Pitch
- Housing Material
- Plastic
- Metal

CUSTOM INTERCONNECT

- Single Ended
- Double Ended
- Multi Limb Cable Assembly
- Strain Relief Backshell
- Environmental Backshell / Boot
- 3600 Screened Backshell
- Moulded Strain Relief
- Woven
- Flexible Circuit



Компания «ЭлектроПласт» предлагает заключение долгосрочных отношений при поставках импортных электронных компонентов на взаимовыгодных условиях!

Наши преимущества:

- Оперативные поставки широкого спектра электронных компонентов отечественного и импортного производства напрямую от производителей и с крупнейших мировых складов;
- Поставка более 17-ти миллионов наименований электронных компонентов;
- Поставка сложных, дефицитных, либо снятых с производства позиций;
- Оперативные сроки поставки под заказ (от 5 рабочих дней);
- Экспресс доставка в любую точку России;
- Техническая поддержка проекта, помощь в подборе аналогов, поставка прототипов;
- Система менеджмента качества сертифицирована по Международному стандарту ISO 9001;
- Лицензия ФСБ на осуществление работ с использованием сведений, составляющих государственную тайну;
- Поставка специализированных компонентов (Xilinx, Altera, Analog Devices, Intersil, Interpoint, Microsemi, Aeroflex, Peregrine, Syfer, Eurofarad, Texas Instrument, Miteq, Cobham, E2V, MA-COM, Hittite, Mini-Circuits, General Dynamics и др.);

Помимо этого, одним из направлений компании «ЭлектроПласт» является направление «Источники питания». Мы предлагаем Вам помощь Конструкторского отдела:

- Подбор оптимального решения, техническое обоснование при выборе компонента;
- Подбор аналогов;
- Консультации по применению компонента;
- Поставка образцов и прототипов;
- Техническая поддержка проекта;
- Защита от снятия компонента с производства.



Как с нами связаться

Телефон: 8 (812) 309 58 32 (многоканальный)

Факс: 8 (812) 320-02-42

Электронная почта: org@eplast1.ru

Адрес: 198099, г. Санкт-Петербург, ул. Калинина, дом 2, корпус 4, литера А.