

39-Bit Battery Backup Multi-Turn Absolute Encoder

Data Sheet



Introduction

The AS37-H39B series encoder is a high-resolution optical absolute encoder produced by Broadcom®, which offers 23-bit single-turn and 16-bit multi-turn counts, hence a combined 39-bit high resolution. The AS37-H39B series encoder is a house encoder consisting of a patterned disk, a light source, and photosensitive elements to translate the mechanical motion into electrical signal.

The AS37-H39B series encoder has a built-in communication protocol that is supported by a full-duplex or half-duplex line transmissions drive, offering good noise immunity for more robust transmission of data up to 10 Mb/s in harsh industrial application. Because the product is intended for industrial application, ESD protection circuitry has been designed in to achieve Class 3 ESD immunity per IEC -61000-4-2 standard. The AS37-H39B series is also compliant with IP40 per IEC 60529 standard.

The key advantage of the AS37-H39B series is multi-turn tracking employs battery backup technology. It is gearless multi-turn counting that eliminates the gear wear-out or acoustics noise issue that is encountered in conventional geared multi-turn encoder.

Operating Theory

Structures-wise, the encoder contains two main functional blocks: the single-turn optical engine block and the battery backup multi-turn counter block. The single-turn engine comprises the Broadcom developed high-performance optical detector ASIC, which is accompanied by high-precision amplifiers circuitry, coupled with a special multi-track code disk that rotates between the LED emitter and detector IC.

On the multi-turn side, the multi-turn counting is enabled utilizing battery backup counter technology. During battery mode (encoder operates in main power OFF state), the battery backup circuitry periodically powers up the LED emitter and enables the photo sensor to scan the code disk multi-turn tracks for detection of shaft rotation. In order to prolong the battery life, extra effort has been put in the design of the ASIC

to ensure minimum current consumption during battery mode operation. Therefore, no miscounts occur even in the absence of external power supply.

Features

- 39-bit resolution: 16-bit battery backup multi-turn and 23-bit optical single-turn
- Built-in communication protocol (option): BiSS C mode, SSI mode and RS-485 half-duplex
- Overall encoder outer diameter Ø37 mm and typical mounting height 28 mm
- Supporting standard hollow taper shaft, short hollow taper shaft and ¼ inch, 6-mm and 8-mm diameter of the hollow blind shaft options.

Benefits

- High resolution with higher measurement accuracy and better speed ripple control.
- Immediate position detection upon power up without the need of system homing.
- Hollow taper shaft design for China Servo motor market.
- Short hollow taper shaft option for low height application.
- Small OD and low height for ease of integration to small size motor.

Applications

- Robotics
- Factory automation
- CNC machine tool

NOTE Broadcom encoders are not recommended for use in safety critical applications, e.g., ABS braking systems, power steering, life support systems, and critical care medical equipment. Contact a sales representative if more clarification is needed.

Product Specifications

Electrical Specifications

Parameter	Conditions	Min.	Typ.	Max.	Unit
Current Consumption	Without load, Tamb = 25°C	—	115	—	mA
Supply Voltage	—	4.5	5	5.5	V
Electrically Permissible Speed	—	—	—	6,000	min ⁻¹
Electrically Permissible Acceleration	Normal mode	—	—	8.0 x 10 ⁴	rad/s ²
	Battery mode	—	—	4.0 x 10 ⁴	
External Battery Supply Voltage	—	—	3.6	4.5	V
Battery Mode Current Consumption	Tamb = 25°C	—	95	—	µA

Note:

Normal mode: Encoder operates on encoder main power supply.

Battery mode: Encoder operates in "OFF" State, while multi-turn data is tracked by battery circuitry

Mechanical Specifications

Parameter	Conditions	Min.	Typ.	Max.	Unit
System Accuracy	With electrical correction, Tamb = 25°C	—	±80	—	Arc-sec
Mechanical Permissible Speed	—	—	—	6,000	min ⁻¹
Shaft Radial Play	—	—	—	±0.05	mm
Shaft Axial Play	—	—	—	±0.1	mm
Starting Torque	Tamb = 25°C	—	—	9.8 x 10 ⁻³	N.m

Environmental Specifications

Parameter	Conditions	Min.	Typ.	Max.	Unit
Storage Temperature	—	-20	—	105	°C
Operating Temperature	—	-20	—	105	°C
Relative Air Humidity (Non-Condensing)	Tamb = 40°C	—	90	—	RH%
Protection	—	—	IP40	—	
Vibration	Per IEC 60068-2-6	—	—	10G; 10~2000 Hz	
Shock	Per IEC 60068-2-27	—	—	6ms; Half Sine; 200G	

Encoder Specifications

Parameter	Remarks
Resolution	Single-turn 23-bit (8388607 counts) and Multi-turn 16-bit (65535 counts).
Counting Direction	Increase with Counter Clockwise (CCW) shaft rotation, view from coupling end (Figure 1).
Initialization Time	500 ms.

Figure 1 Shaft Rotation

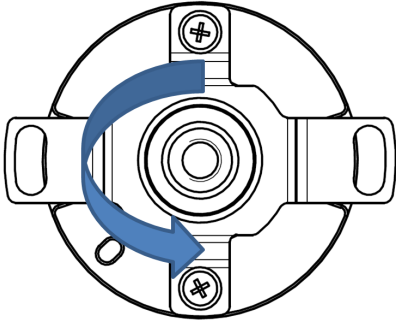

NOTE Exposure to absolute maximum rating conditions for extended periods might affect reliability.

Interface Diagram

The following are examples of the circuit diagram of full-duplex and half-duplex transceiver.

Full-Duplex Transceiver (BiSS C Mode/SSI Mode Protocol)

Figure 2 Circuit Diagram of Full-Duplex Transceiver

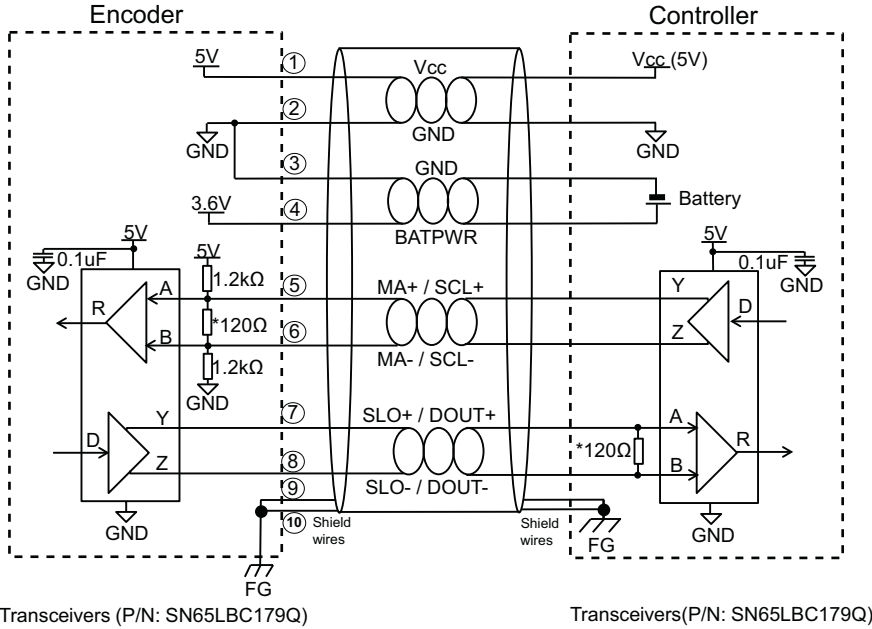

Half-Duplex Transceiver (RS-485 Half-Duplex Protocol)

Figure 3 Circuit Diagram of Half-Duplex Transceiver

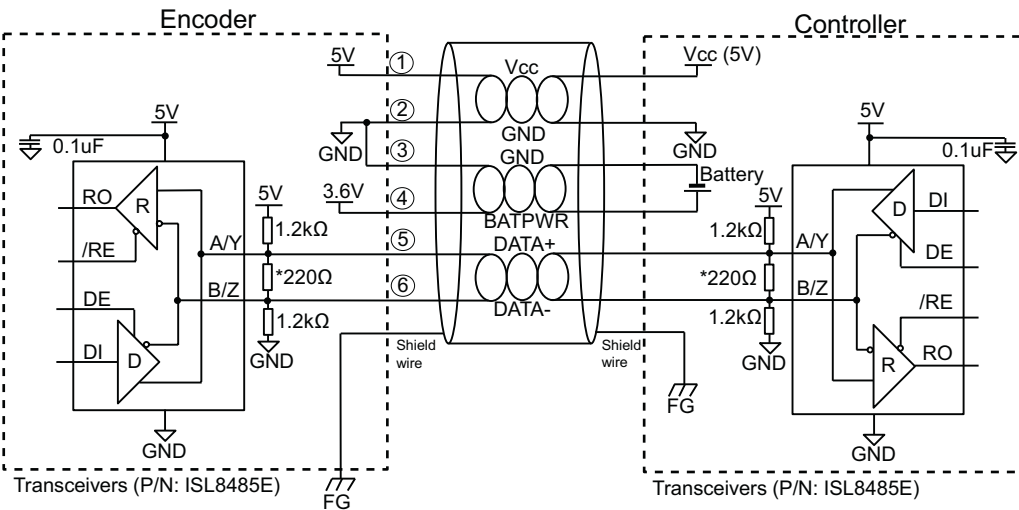

* Termination resistor, 120Ω and 220Ω are recommended but may depend on the characteristic impedance of cable used.

NOTE Connect encoder chassis and cable shield to frame ground (FG) in application for enhanced noise immunity in harsh operating conditions.

Connector Output Assignment

Pin	AS37-H39B-Bxxx (BiSS-C) (Output: 10-Pin Connector)	AS37-H39B-Sxxx (SSI) (Output: 10-Pin Connector)	AS37-H39B-Kxxx (RS-485 Half-Duplex) (Output: 7-Pin Connector)
1	Vcc, Encoder Supply	Vcc, Encoder Supply	Vcc, Encoder Supply
2	GND, Ground	GND, Ground	GND, Ground
3	GND (External Battery)	GND (External Battery)	GND (External Battery)
4	BATPWR (External Battery)	BATPWR (External Battery)	BATPWR (External Battery)
5	MA+	SCL+	DATA+
6	MA-	SCL-	DATA-
7	SLO+	DOU+	Cable Shield, Connect to Chassis
8	SLO-	DOU-	N/A
9	Cable Shield, Connect to Chassis	Cable Shield, Connect to Chassis	N/A
10	Cable Shield, Connect to Chassis	Cable Shield, Connect to Chassis	N/A

Figure 4 7-Pin Connector Pin Assignment

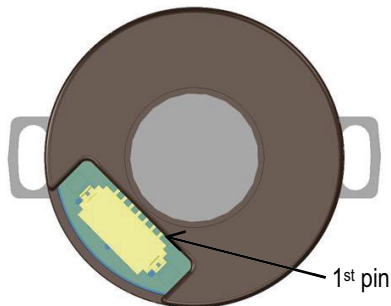
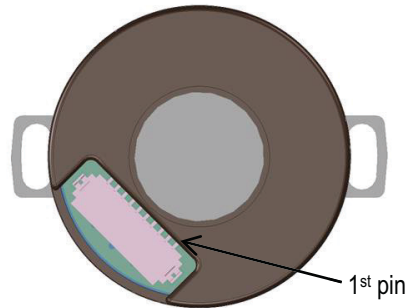

Figure 5 10-Pin Connector Pin Assignment



NOTE Recommended mating connector:

Hirose Part No: DF13-7S-1.25C for 7-pin connector and DF13-10S-1.25C for 10-pin connector (CL No.536-0006-8).

Hirose (Terminal Pin for Wire 26~30AWG): DF13-2630SCF (CL No.536-0300-5).

Mechanical Outline

Standard Hollow Taper Shaft Option ($\Phi 9$ to $\Phi 7.5$ mm; 1:10)

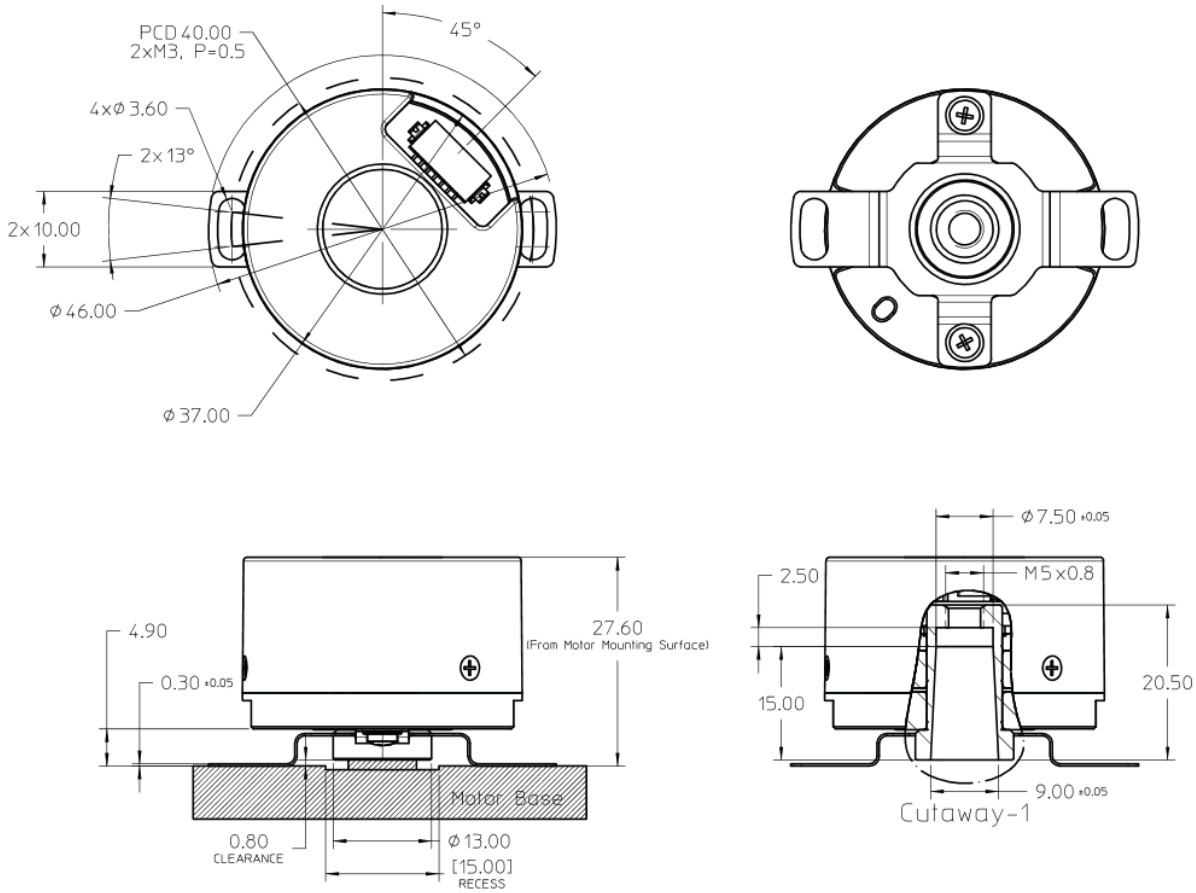

Recommended Shaft and Mounting Requirement

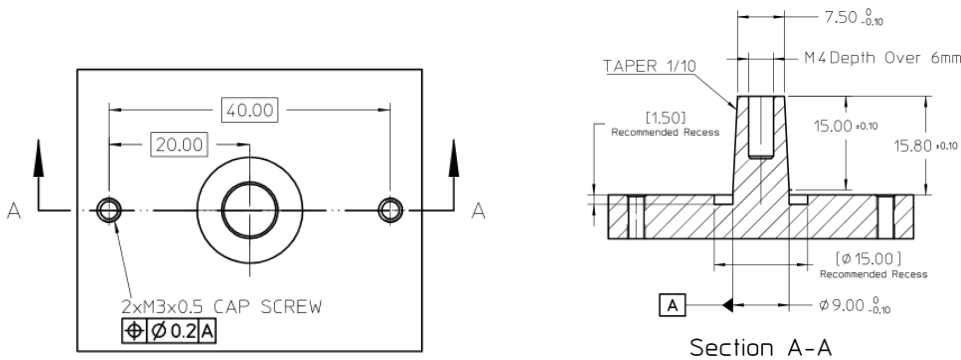

Notes:

Dimensions are in millimeters.

3rd angle projection.

Unless otherwise specified, all tolerances are within ± 0.5 mm.

Recommended to have a recess on motor mounting surface to prevent encoder shaft interference with motor base.

Short Hollow Taper Shaft Option ($\Phi 9$ to $\Phi 7.65$ mm; 1:10)

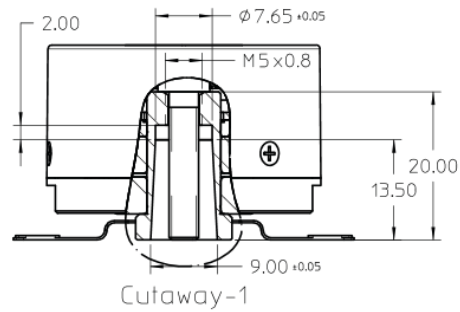
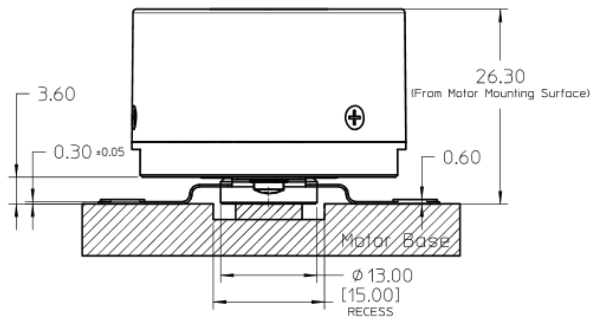
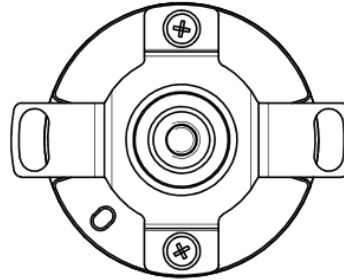
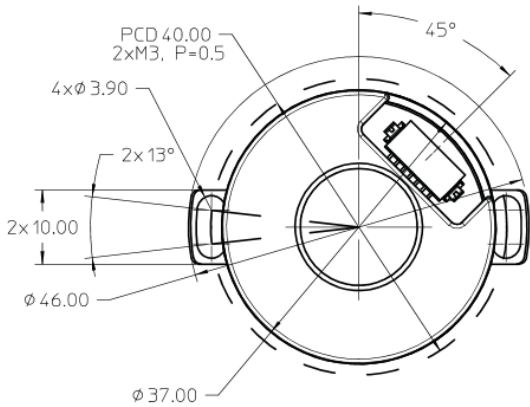

Recommended Shaft and Mounting Requirement

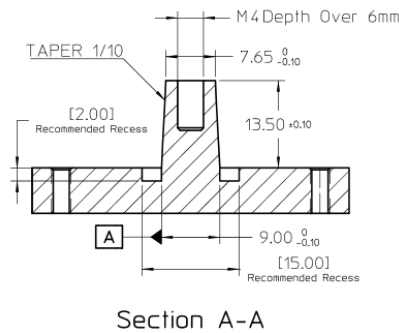
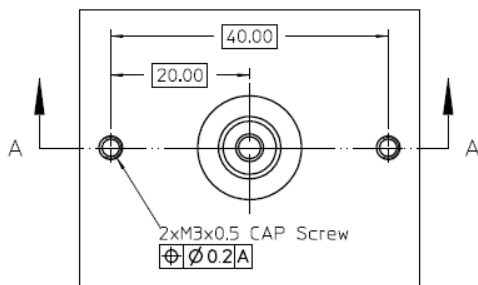

Notes:

Dimensions are in millimeters.

3rd angle projection.

Unless otherwise specified, all tolerances are within ± 0.5 mm.

Recommended to have a recess on motor mounting surface to prevent encoder shaft interference with motor base.

Hollow Blind Shaft Option (Φ8 mm)

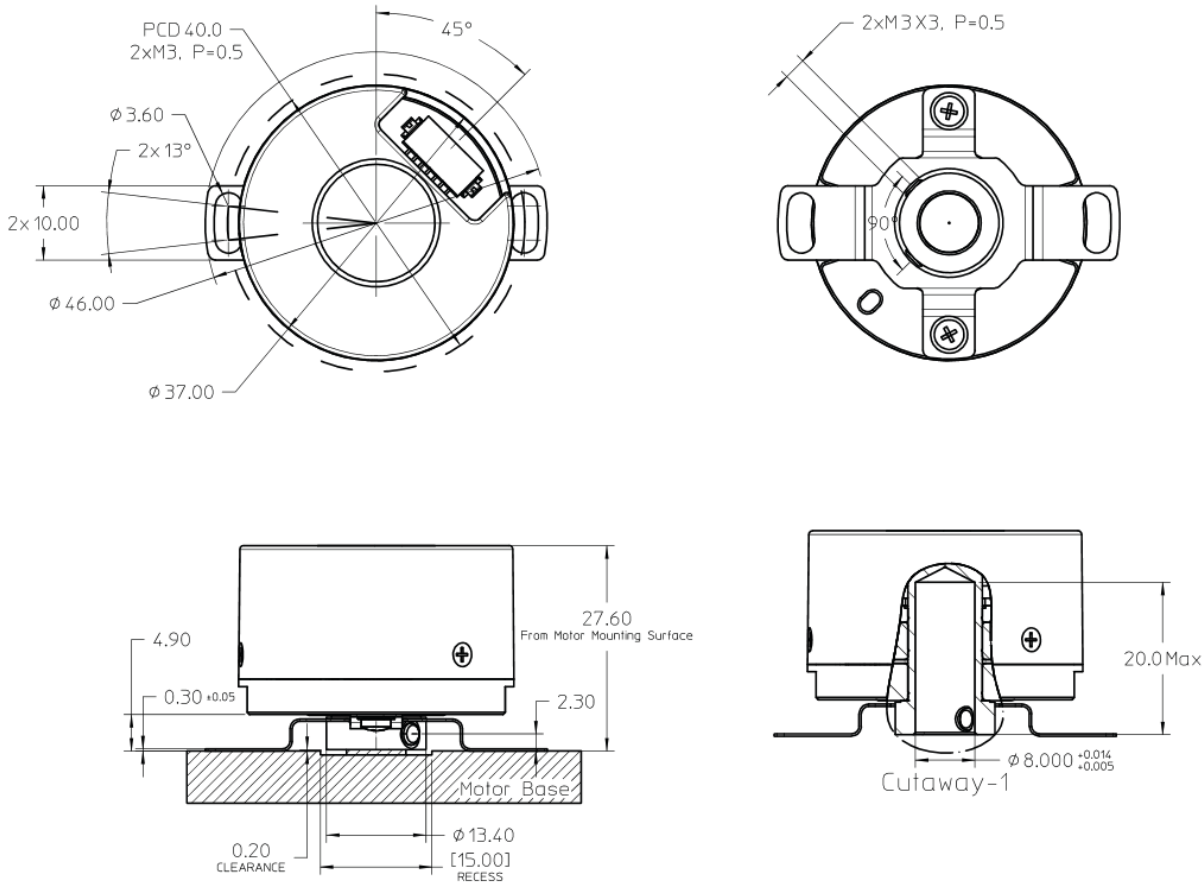

Recommended Shaft and Mounting Requirement

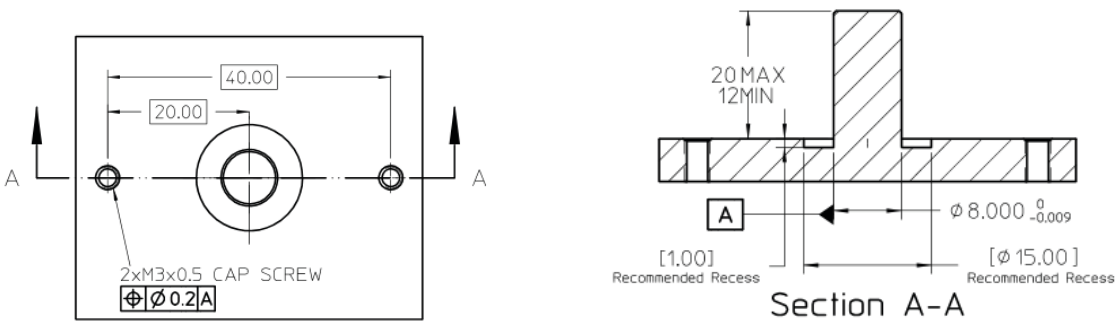

- Notes:
- Dimensions are in millimeters.
 - 3rd angle projection.
 - Unless otherwise specified, all tolerances are within ± 0.5 mm.
 - Recommended to have a recess on motor mounting surface to prevent encoder shaft interference with motor base.

Ordering Information

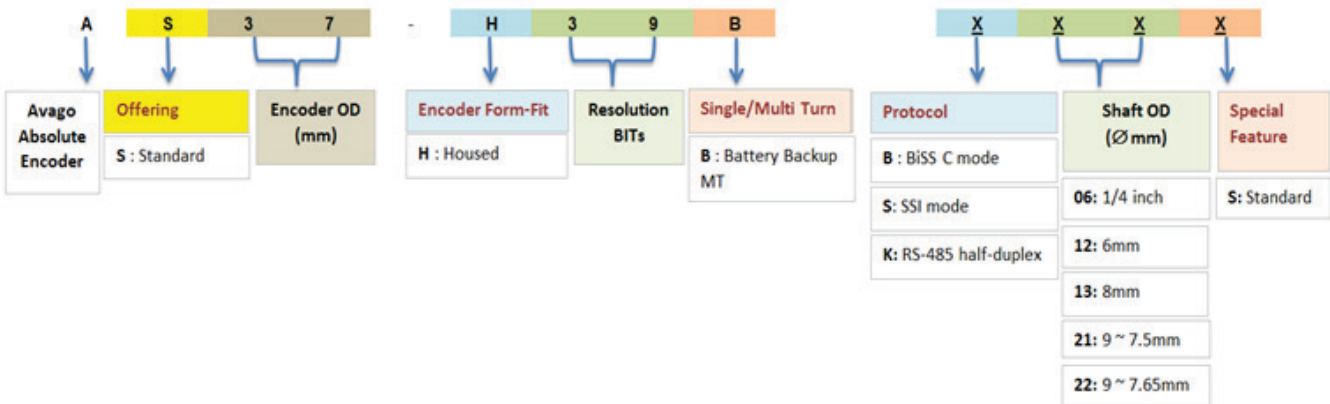

NOTE Refer to the factory for sample order and lead time.

For product information and a complete list of distributors, please go to our web site: www.broadcom.com.

Broadcom, the pulse logo, Connecting everything, Avago Technologies, Avago, and the A logo are among the trademarks of Broadcom in the United States, certain other countries and/or the EU.

Copyright © 2017 Broadcom. All Rights Reserved.

The term "Broadcom" refers to Broadcom Limited and/or its subsidiaries. For more information, please visit www.broadcom.com.

Broadcom reserves the right to make changes without further notice to any products or data herein to improve reliability, function, or design.

Information furnished by Broadcom is believed to be accurate and reliable. However, Broadcom does not assume any liability arising out of the application or use of this information, nor the application or use of any product or circuit described herein, neither does it convey any license under its patent rights nor the rights of others.

AS37-H39B-DS100 – March 31, 2017





Компания «ЭлектроПласт» предлагает заключение долгосрочных отношений при поставках импортных электронных компонентов на взаимовыгодных условиях!

Наши преимущества:

- Оперативные поставки широкого спектра электронных компонентов отечественного и импортного производства напрямую от производителей и с крупнейших мировых складов;
- Поставка более 17-ти миллионов наименований электронных компонентов;
- Поставка сложных, дефицитных, либо снятых с производства позиций;
- Оперативные сроки поставки под заказ (от 5 рабочих дней);
- Экспресс доставка в любую точку России;
- Техническая поддержка проекта, помощь в подборе аналогов, поставка прототипов;
- Система менеджмента качества сертифицирована по Международному стандарту ISO 9001;
- Лицензия ФСБ на осуществление работ с использованием сведений, составляющих государственную тайну;
- Поставка специализированных компонентов (Xilinx, Altera, Analog Devices, Intersil, Interpoint, Microsemi, Aeroflex, Peregrine, Syfer, Eurofarad, Texas Instrument, Miteq, Cobham, E2V, MA-COM, Hittite, Mini-Circuits, General Dynamics и др.);

Помимо этого, одним из направлений компании «ЭлектроПласт» является направление «Источники питания». Мы предлагаем Вам помощь Конструкторского отдела:

- Подбор оптимального решения, техническое обоснование при выборе компонента;
- Подбор аналогов;
- Консультации по применению компонента;
- Поставка образцов и прототипов;
- Техническая поддержка проекта;
- Защита от снятия компонента с производства.



Как с нами связаться

Телефон: 8 (812) 309 58 32 (многоканальный)

Факс: 8 (812) 320-02-42

Электронная почта: org@eplast1.ru

Адрес: 198099, г. Санкт-Петербург, ул. Калинина, дом 2, корпус 4, литера А.