

**Signal Contacts**

**Type III+, Crimp, Snap-In**

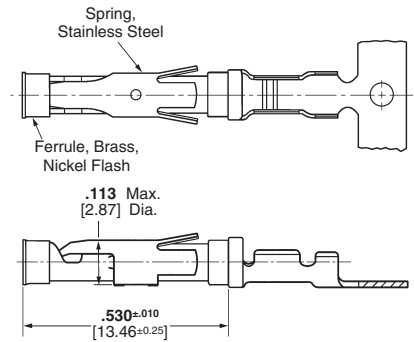
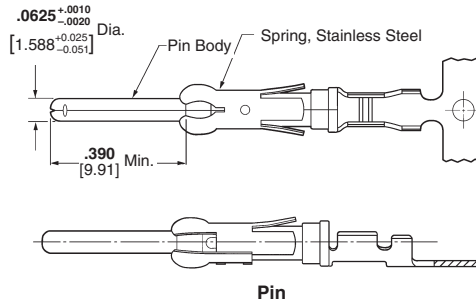
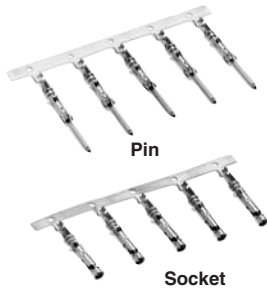

**Material and Finish** — See chart.  
**Contact Body**—Brass or phosphor bronze  
**Retention Spring**—Stainless steel

**Application Tooling**—Page 29  
**Technical Documents**  
 114-10004 Application Specification  
 108-10042 Product Specification

**Contact Size 16—Pin Diameter .062 [1.57] (Test Current, 13 Ampere)†**

†Single contact, free-air test current is not to be construed as contact rating current. Use only for testing. Refer to contact current carrying capability information on page 8.

| AWG   | Wire Size Range<br>mm <sup>2</sup> | Ins. Dia. Range                     | Contact Finish                | Strip Form Contact No. |                        | Loose Piece Contact No. |           | Tooling Part No.**                                 |   |
|-------|------------------------------------|-------------------------------------|-------------------------------|------------------------|------------------------|-------------------------|-----------|--|---|
|       |                                    |                                     |                               | Pin                    | Socket                 | Pin                     | Socket    | Loose Piece Hand Tool                              | Strip Form Applicators                          |
| 30-28 | 0.05-0.09                          | .015-.030<br>0.38-0.76              | Gold/Nickel <sup>2</sup>      | 788085-3               | 788088-2               | —                       | —         | 90716-1  | 567867-1***<br>or 567947-1***<br>or 680602-□*** |
|       |                                    |                                     | Sel. Gold/Nickel <sup>3</sup> | 788085-1               | 788088-1               | 788085-4                | 788088-3  |  |   |
| 30-26 | 0.05-0.15                          | .040-.060 <sup>1</sup><br>1.02-1.52 | Bright Tin                    | 1-66425-2              | 1-66424-1              | —                       | —         | 91515-1 <sup>6</sup>                               | 466598-□***                                     |
|       |                                    |                                     | Gold/Nickel <sup>2</sup>      | 66425-7                | 66424-7                | 66429-3                 | 66428-3   |  |   |
|       |                                    |                                     | Sel. Gold/Nickel <sup>3</sup> | 66425-8                | 66424-8                | 66429-4                 | 66428-4   |  |   |
|       |                                    |                                     | Gold/Nickel <sup>2</sup>      | 66393-7                | 66394-7                | —                       | —         |  |   |
| 26-24 | 0.12-0.2                           | .035-.055 <sup>1</sup><br>0.89-1.40 | Sel. Gold/Nickel <sup>3</sup> | 66393-8                | 66394-8                | 66406-4                 | 66405-4   | 90225-2 <sup>6</sup>                               | 466585-3***                                     |
|       |                                    |                                     | Bright Tin                    | 1-66106-5              | 1-66108-5              | 1-66107-1               | 1-66109-7 |  |   |
|       |                                    |                                     | Gold/Nickel <sup>2</sup>      | 66106-7                | 66108-7                | 66107-3                 | 66109-3   |  |   |
|       |                                    |                                     | Sel. Gold/Nickel <sup>3</sup> | 66106-8                | 66108-8                | 66107-4                 | 66109-4   |  |   |
| 24-20 | 0.2-0.6                            | .040-.080 <sup>1</sup><br>1.02-2.03 | Sel. Gold/Nickel <sup>4</sup> | —                      | 66108-1                | —                       | 66109-1   | 91515-1 <sup>6</sup><br>or<br>58495-1*             | 466321-□***<br>or<br>466908-2***                |
|       |                                    |                                     | Bright Tin                    | 2-66102-5              | 3-66104-0              | 1-66103-8               | 1-66105-9 |  |   |
|       |                                    |                                     | Gold/Nickel <sup>2</sup>      | 66102-8                | 66104-8                | 66103-3                 | 66105-3   |  |   |
|       |                                    |                                     | Sel. Gold/Nickel <sup>3</sup> | 66102-9                | 66104-9                | 66103-4                 | 66105-4   |  |   |
|       |                                    |                                     | Sel. Gold/Nickel <sup>4</sup> | 2-66102-2 <sup>7</sup> | 2-66104-3 <sup>7</sup> | —                       | —         |  |   |
|       |                                    |                                     | Sel. Gold/Nickel <sup>4</sup> | —                      | 66104-1                | —                       | 66105-1   |  |   |
| 18-16 | 0.8-1.4                            | .080-.100 <sup>1</sup><br>2.03-2.54 | Bright Tin                    | 1-66564-2              | 1-66563-1              | 66566-7                 | 66565-7   | 91542-1 <sup>6</sup>                               | 466383-4***<br>or 466979-1***<br>or 567363-□*** |
|       |                                    |                                     | Sel. Gold/Nickel <sup>3</sup> | 66564-8                | 66563-8                | 66566-4                 | 66565-4   |  |   |
|       |                                    |                                     | Bright Tin                    | 1-66332-4              | 1-66331-4              | 1-66400-0               | 1-66399-0 |  |   |
|       |                                    |                                     | Gold/Nickel <sup>2</sup>      | 66332-7                | 66331-7                | 66400-3                 | 66399-3   |  |   |
| 18-14 | 0.8-2.0                            | .080-.100 <sup>1</sup><br>2.03-2.54 | Sel. Gold/Nickel <sup>3</sup> | 66332-8                | 66331-8                | 66400-4                 | 66399-4   | 91523-1 <sup>6</sup><br>or<br>90225-2 <sup>6</sup> | 466324-□***<br>or<br>466942-1***                |
|       |                                    |                                     | Sel. Gold/Nickel <sup>4</sup> | —                      | 66331-2                | —                       | 66399-2   |  |   |
|       |                                    |                                     | Bright Tin                    | 1-66098-9 <sup>5</sup> | 1-66100-9              | 1-66099-5               | 1-66101-9 |  |   |
|       |                                    |                                     | Gold/Nickel <sup>2</sup>      | 66098-8                | 66100-8                | 66099-3                 | 66101-3   |  |   |
| 18-14 | 0.8-2.0                            | .080-.100 <sup>1</sup><br>2.03-2.54 | Sel. Gold/Nickel <sup>3</sup> | 66098-9                | 66100-9                | 66099-4                 | 66101-4   | 91519-1 <sup>6</sup>                               | 466326-□***<br>or<br>466923-2***                |
|       |                                    |                                     | Sel. Gold/Nickel <sup>4</sup> | 66098-6                | —                      | 66099-1                 | —         |  |   |
|       |                                    |                                     | Bright Tin                    | 1-66359-4              | 1-66358-6              | 1-66361-2               | 1-66360-2 |  |   |
|       |                                    |                                     | Phos Bronze                   | 1-66359-5              | 1-66358-8              | 1-66359-5               | 1-66358-8 |  |   |
|       |                                    |                                     | Gold/Nickel <sup>2</sup>      | 66359-9                | 66358-9                | 66361-3                 | 66360-3   |  |   |
|       |                                    |                                     | Sel. Gold/Nickel <sup>3</sup> | 1-66359-0              | 1-66358-0              | 66361-4                 | 66360-4   |  |   |
| 18-14 | 0.8-2.0                            | .110-.150 <sup>5</sup><br>2.79-3.81 | Sel. Gold/Nickel <sup>4</sup> | 1-66359-2              | 1-66358-3              | 66361-8                 | 66360-8   | 91521-1 <sup>6</sup>                               | 466958-1***<br>or<br>567364-□***                |
|       |                                    |                                     | Sel. Gold/Nickel <sup>4</sup> | —                      | 66358-1                | —                       | 66360-1   |  |   |
|       |                                    |                                     | Bright Tin                    | 66597-8                | 1-66598-0              | 66602-8                 | 66601-9   |  |   |
|       |                                    |                                     | Sel. Gold/Nickel <sup>3</sup> | 66597-2                | 66598-2                | 66602-2                 | 66601-2   |  |   |

<sup>1</sup>Overall insulation crimp diameter, including crimp barrel, must not exceed .125 [3.18].  
<sup>2</sup>.000015 [0.00038] gold in the mating area over .000050 [0.00127] min. nickel.  
<sup>3</sup>.000030 [0.00076] gold in the mating area, with gold flash on remainder, over .000050 [0.00127] min. nickel.  
<sup>4</sup>.000030 [0.00076] gold in the mating area, with gold gradient on remainder, over .000050 [0.00127] min. nickel.

<sup>5</sup>Contacts can ONLY be used in: Metrimate; CPC Series 1 (Arr. 23-24), Series 4 (Arr. 23-13M, 23-16M, 23-22M), and VDE connectors.  
<sup>6</sup>To use with the 626 Pneumatic Tool: remove crimping head from Straight Action Hand Tool (SAHT), order SAHT Adapter Part No. 217201-1, Adapter Holder Part No. 356304-1 (with ratchet) or 189928-1 (without), and Power Unit Part No. 189721-1 (hand actuated) or 189722-1 (foot actuated).  
<sup>7</sup>Phosphor Bronze

<sup>8</sup>Standard reeling of strip form contacts.  
<sup>\*</sup>Commercial PRO-CRIMPER II hand tool for field repair only. Note: Die Set can be adapted for use with 626 Pneumatic Tool System. Insertion Tool Part No. 91002-1 (for insulation diameters .070 [1.78] or less), No. 200893-2 (for insulation diameters .090 [2.29] max.). Extraction Tool Part No. 305183. (Instruction Sheet 408-1216)  
<sup>\*\*</sup>There are power options available for these tools/dies. See Battery Powered Crimp tool Kit and SDE Electric Terminator on page 30.  
<sup>\*\*\*</sup>Call Technical Support for Machine Applicator Part Numbers.

**Note:** All part numbers are RoHS compliant.

**Signal Contacts** (Continued)

**Type III+, Crimp, Snap-In**

**Contact Size**—16  
**Pin Diameter**—.062 [1.57]

**Material and Finish**  
**Contact Body**—Copper alloy, plated tin or gold  
**Spring**—Stainless steel

**Grounding Pin**  
 (make first - break last)

**Related Product Data**  
**Application Tooling**—Pages 29, 30  
**Technical Documents**—Page 4

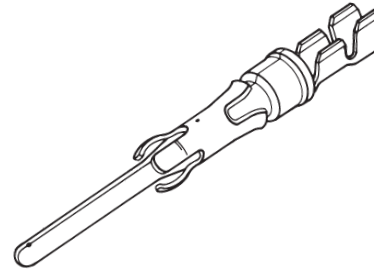

| Wire Size Range    |       | Ins. Dia. Range <sup>1</sup> | Contact Finish                | Grounding Pin Part No. |             | Strip Form Applicator Part No. | Loose Piece Hand Tool** Part No.                         |
|--------------------|-------|------------------------------|-------------------------------|------------------------|-------------|--------------------------------|--|
| [mm <sup>2</sup> ] | AWG   |                              |                               | Strip Form             | Loose Piece |                                |  |
| 0.12-0.2           | 26-24 | .035-.055<br>0.89-1.4        | Tin                           | 164159-3               | 164162-1    | —                              | 91515-1 <sup>3</sup> or 58495-1*                         |
|                    |       |                              | Sel. Gold/Nickel <sup>2</sup> | 164159-4               | 164162-2    |                                |  |
| 0.2-0.6            | 24-20 | .045-.070<br>1.14-1.78       | Tin                           | 164160-3               | 164163-1    | 466323-□ <sup>3</sup>          | 91515-1 <sup>3</sup> or 91505-1 <sup>3</sup> or 58495-1* |
|                    |       |                              | Sel. Gold/Nickel <sup>2</sup> | 164160-4               | 164163-2    | 466907-2 <sup>3</sup>          |  |
| 0.8-1.4            | 18-16 | .078-.098<br>1.98-2.49       | Tin                           | 164161-3               | 164164-1    | 466741-□ <sup>3</sup>          | 91523-1 <sup>3</sup> or 91505-1 <sup>3</sup> or 58495-1* |
|                    |       |                              | Sel. Gold/Nickel <sup>2</sup> | 164161-4               | 164164-2    | 680114-3 <sup>3</sup>          |  |

<sup>1</sup>Overall insulation crimp diameter, including crimp barrel, must not exceed .125 [3.18].  
<sup>2</sup>Gold flash over .000030 [0.00076] min. nickel on entire contact, with .000030 [0.00076] gold in contact area.  
<sup>3</sup>To use with the 626 Pneumatic Tool System: remove the crimping head from the Straight Action Hand Tool (SAHT) Assembly, order SAHT Adapter **Part No. (Call Technical Support at 800-522-6752)**, Adapter Holder **Part No. 356304-1** (with ratchet) or **189928-1** (without), and Power Unit **Part No. 189721-1** (hand actuated) or **189722-1** (foot actuated).

\*Commercial PRO-CRIMPER II hand tool for field repair only. **Note:** Die Set can be adapted for use with the 626 Pneumatic Tool System.  
 \*\*There are power options available for these tools/dies. See Battery Powered Crimp tool Kit and SDE Electric Terminator on page 30.  
 \*\*\*Call Technical Support at 1-800-522-6752 for Automatic Machine Applicator Part Numbers.

**Extraction Tool Part No. 725840-1**

**Note:** All part numbers are RoHS compliant.

**Type III+, Solder Versions**

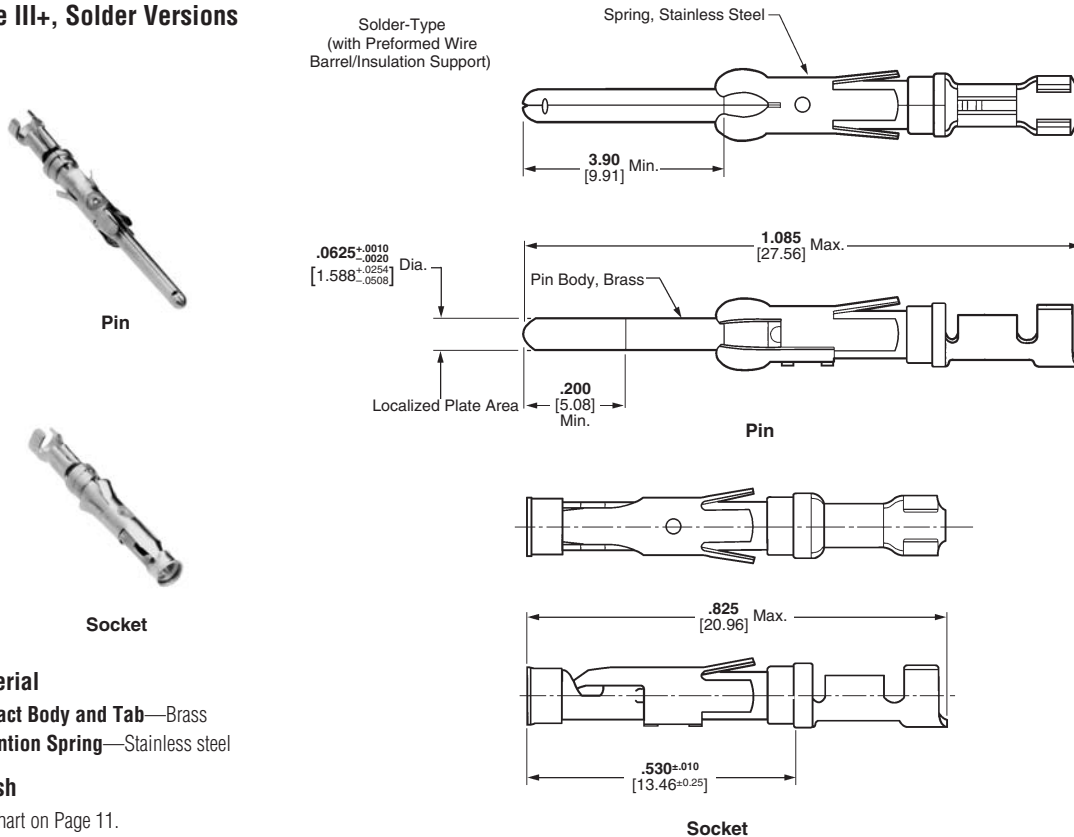

**Material**  
**Contact Body and Tab**—Brass  
**Retention Spring**—Stainless steel

**Finish**  
 See chart on Page 11.

**Signal Contacts** (Continued)

**Type III+, Solder Versions**  
(Continued)



Pin



Socket

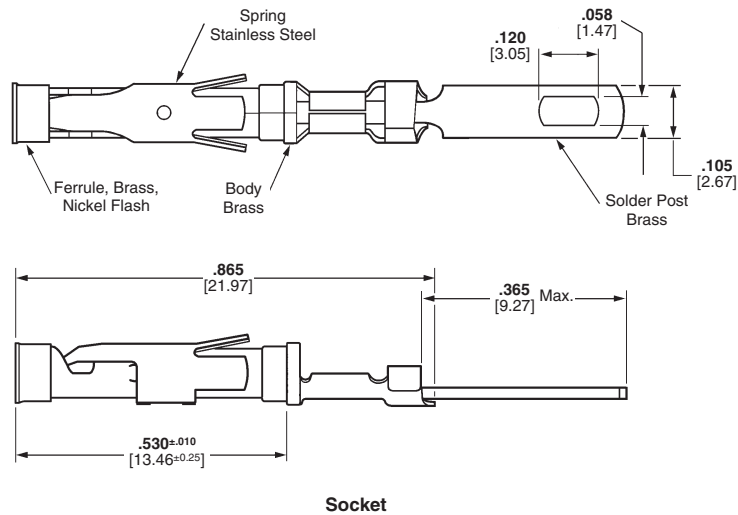
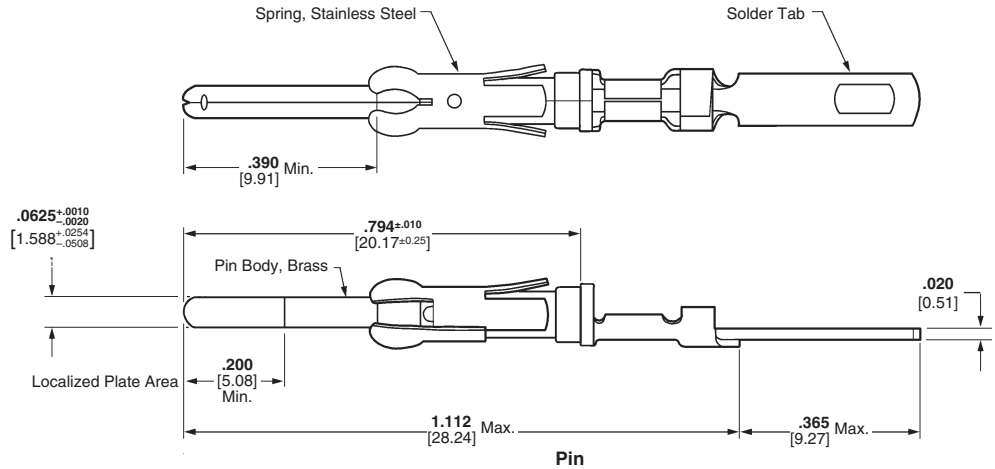

**Material**

**Contact Body and Tab**—Brass

**Retention Spring**—Stainless steel

**Finish**

See chart.

**Contact Size 16—Pin Diameter .062 [1.57] (Test Current, 13 Ampere)‡**

| Wire Size Range |                    | Contact Finish           | Loose Piece Contact No. |           |
|-----------------|--------------------|--------------------------|-------------------------|-----------|
| AWG             | [mm <sup>2</sup> ] |                          | Pin                     | Socket    |
| 26-20           | 0.12-0.6           | Gold/Nickel <sup>1</sup> | 66182-1♦                | 66183-1♦  |
| 18-16           | 0.8-1.4            | Gold/Nickel <sup>1</sup> | 66180-1♦                | 66181-1♦  |
| Solder Tab      |                    | Duplex <sup>2</sup>      | 202236-7♦               | 202237-7♦ |
|                 |                    | Bright Tin               | 202236-5♦               | 202237-5♦ |

<sup>1</sup>0.00030 [0.00076] gold in mating area over .000050 [0.00127] nickel.

<sup>2</sup>Duplex plated .000030 [0.00076] gold in mating area over .000050 [0.00127] nickel on contact body; bright tin-lead on solder tab.

<sup>3</sup>Bright tin on entire contact.

**Note:** These contacts can be used in Multimate contact cavities of all connector housings.

‡Single contact, free-air test current is not to be construed as contact rating current. Use only for testing.

Refer to contact current carrying capability information on page 3.

Extraction Tool **Part No. 305183** (Instruction Sheet 408-1216)

**Note:** All part numbers are RoHS compliant except: ♦ Indicates non-RoHS compliant.

**Signal Contacts** (Continued)

**Type III+, Posted**  
(Replacement Contacts,  
See Note Below)



Pin



Socket

**Material**

**Contact Body and Post**—Brass

**Retention Spring**—Stainless steel

**Finish**

See chart.

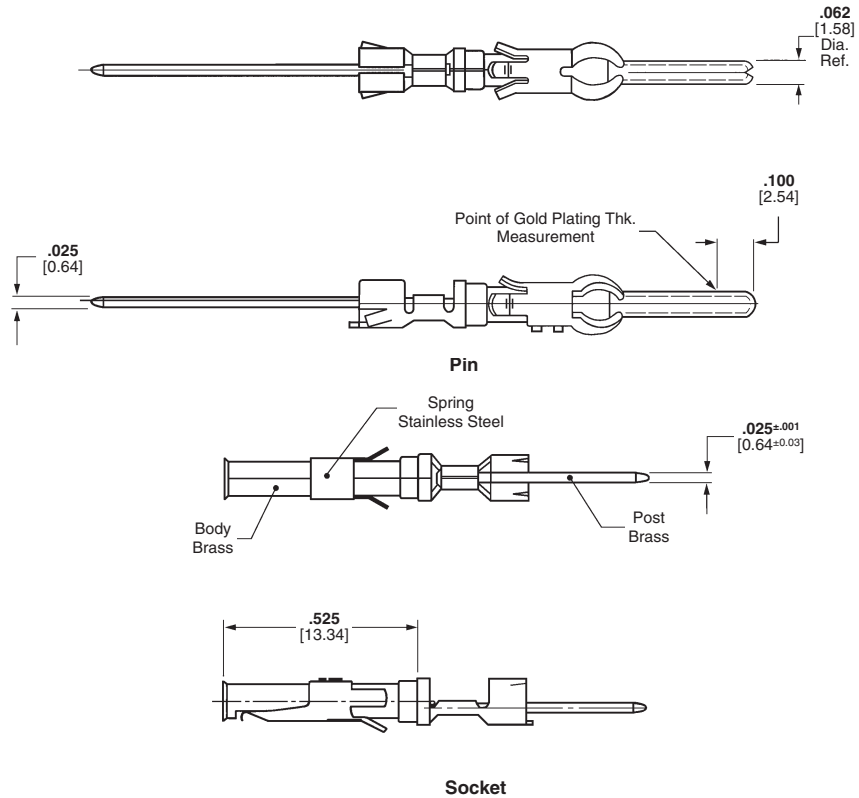

**Contact Size 16—Pin Diameter .062 [1.57] (Test Current, 13 Ampere)‡**

| Termination Method  | Post Configuration         | Contact Finish                | Loose Piece Contact No. |           |                         |           |                         |           |
|---------------------|----------------------------|-------------------------------|-------------------------|-----------|-------------------------|-----------|-------------------------|-----------|
|                     |                            |                               | 3 Termination High Post |           | 2 Termination High Post |           | 1 Termination High Post |           |
|                     |                            |                               | Pin                     | Socket    | Pin                     | Socket    | Pin                     | Socket    |
| Wrap-Type           | .025 x .025<br>0.64 x 0.64 | Sel. Gold/Nickel <sup>1</sup> | 6-66460-4               | 6-66461-3 | 6-66460-3               | 6-66461-2 | 6-66460-2               | 5-66461-5 |
|                     |                            | Bright Tin                    | 6-66460-6               | 5-66461-9 | 6-66460-7               | 5-66461-8 | 6-66460-5               | 5-66461-4 |
|                     | .045 x .045<br>1.14 x 1.14 | Sel. Gold/Nickel <sup>1</sup> | 1-66471-5               | 2-66473-0 | —                       | —         | 1-66471-8               | 1-66473-9 |
|                     |                            | Bright Tin                    | 1-66471-7               | 1-66473-8 | —                       | —         | 1-66471-6               | 1-66473-7 |
| TERMI-POINT<br>Clip | .031 x .062<br>0.79 x 1.57 | Sel. Gold/Nickel <sup>1</sup> | 1-66470-1               | —         | —                       | —         | 1-66470-0               | —         |
|                     |                            | Sel. Gold/Nickel <sup>1</sup> | 1-66468-3               | 1-66459-0 | —                       | —         | —                       | —         |

<sup>1</sup>Gold flash over .000050 [0.00127] nickel on entire contact, with .000030 [0.00076] gold to a distance of .200 [5.08] from mating end. Gold thickness controlled on socket O.D.

Posts plated tin-lead over copper.

Extraction Tool **Part No. 305183** (Instruction Sheet 408-1216)

Insertion Tool **Part No. 200893-2**

**Note:** These contacts are used as replacement contacts for all posted connectors.

‡Single contact, free-air test current is not to be construed as contact rating current. Use only for testing. Refer to contact current carrying capability information on page 3.

**Note:** All part numbers are RoHS compliant.

**Signal Contacts** (Continued)

**Enhanced High Current Type III+, Crimp, Snap-In**

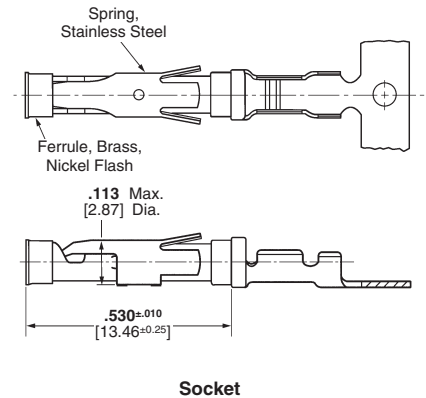
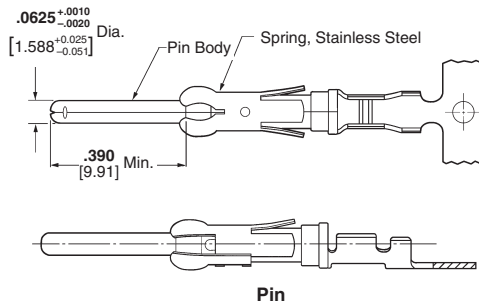
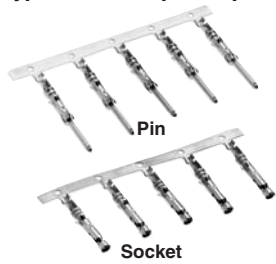

**Material and Finish** — See chart.  
**Contact Body**—Copper Nickel Alloy  
**Retention Spring**—Stainless steel

**Related Product Data**

**Application Tooling** — Pages 75-78

**Technical Documents**

114-10004 Application Specification  
 108-10024-2 Product Specification

**Contact Size 16—Pin Diameter .062 [1.57]**

| Wire Size Range |                 | Ins. Dia. Range                     | Contact Finish | Strip Form Contact No. |           | Loose Piece Contact No. |           | Tooling Part No.**    |                                  |
|-----------------|-----------------|-------------------------------------|----------------|------------------------|-----------|-------------------------|-----------|-----------------------|----------------------------------|
| AWG             | mm <sup>2</sup> |                                     |                | Pin                    | Socket    | Pin                     | Socket    | Loose Piece Hand Tool | Strip Form Applicators           |
| 18-14           | 0.8-2.0         | .080-.100 <sup>1</sup><br>2.03-2.54 | Gold           | 1-66359-6              | 1-66358-9 | 1-66361-4               | 1-66360-4 | 91519-1 <sup>3</sup>  | 466326-□***<br>or<br>466923-2*** |
|                 |                 |                                     | Tin            | 1-66359-9              | 2-66358-1 | 1-66361-6               | 1-66360-6 |                       | 466958-1***<br>or<br>567364-□*** |
|                 |                 | .110-.150 <sup>2</sup><br>2.79-3.81 | Gold           | 1-66597-0              | 1-66598-1 | 66602-9                 | 1-66601-0 | 91521-1 <sup>3</sup>  | 466958-1***<br>or<br>567364-□*** |
|                 |                 |                                     | Tin            | 1-66597-1              | 1-66598-2 | 1-66602-0               | 1-66601-2 |                       |                                  |

<sup>1</sup> Overall insulation crimp diameter, including crimp barrel, must not exceed .125 [3.18].  
<sup>2</sup> Contacts can ONLY be used in CPC, Series 1 (Arr. 23-24), Series 4 (Arr. 23-13M, 23-16M, 23-22M), and VDE connectors.  
<sup>3</sup> To use with the 626 Pneumatic Tool System: remove the crimping head from the Straight Action Hand Tool (SAHT) Assembly, order SAHT Adapter **Part No. 217201-1**, Adapter Holder **Part No. 356304-1** (with ratchet) or **189928-1** (without), and Power Unit **Part No. 189721-1** (hand actuated) or **189722-1** (foot actuated).  
 \*\*There are power options available for these tools/dies. See Battery Powered Crimp tool Kit and SDE Electric Terminator on page 30.  
 \*\*\*Call Technical Support for Automatic Machine Applicator Part Numbers.

**Note:** All part numbers are RoHS compliant.

**Ratings Voltage:** 250 Volts AC/DC  
 600 Volts AC/DC, Series I, VDE tested and select loaded only  
**Base Current:** Type III+ contacts: 17 amperes, 30°C temperature rise with single contact on 14 AWG wire  
**Enhanced High Current Type III+ contacts: 25 amperes**, 30°C temperature rise with single contact on 14 AWG wire  
**Temperature:** -55°C to +105°C  
**VDE 0627:** XA/630/4KV/2 - Series I, VDE tested only

**Multiplication Rating Factor (F)**

**Type III+ Contacts (Note: 1 = 17 amperes)**

| Shell Size | Percent Connector Loading |        |           |        |           |        |
|------------|---------------------------|--------|-----------|--------|-----------|--------|
|            | Single Circuit            |        | ≈ 50%     |        | 100%      |        |
|            | Wire Size                 |        | Wire Size |        | Wire Size |        |
|            | 30 AWG                    | 14 AWG | 30 AWG    | 14 AWG | 30 AWG    | 14 AWG |
| 11-4       | .291                      | 1      | .212      | .905   | .140      | .684   |
| 13-9       | .278                      | .995   | .175      | .750   | .134      | .567   |
| 17-16      | .270                      | .990   | .146      | .625   | .127      | .472   |
| 23-24      | .281                      | .985   | .138      | .550   | .120      | .416   |
| 23-37      | .275                      | .985   | .131      | .497   | .114      | .376   |

**Enhanced High Current Type III+ Contacts (14 AWG wire only - Note: 1 = 25 amperes)**

| Shell Size | Percent Connector Loading |        |        |
|------------|---------------------------|--------|--------|
|            | Single Circuit            | ≈ 50%  | 100%   |
|            | 14 AWG                    | 14 AWG | 14 AWG |
| 11-4       | .880                      | .840   | .640   |
| 13-9       | .880                      | .640   | .480   |
| 17-16      | .880                      | .520   | .400   |
| 23-24      | .880                      | .520   | .400   |
| 23-37      | .880                      | .440   | .320   |

**Enhanced High Current Contacts & M Series Connectors:**

**(Note: 1 = 24 amperes)**

| Single Circuit | ≈ 50%  | ≈ 100% |
|----------------|--------|--------|
| 14 AWG         | 14 AWG | 14 AWG |
| 1              | .292   | .250   |

**Enhanced High Current Contacts & Metrimate Connectors:**

**(Note: 1 = 24 amperes)**

| Single Circuit | ≈ 50%  | ≈ 100% |
|----------------|--------|--------|
| 14 AWG         | 14 AWG | 14 AWG |
| 1              | .458   | .375   |

**Signal Contacts** (Continued)

**Type II, Screw Machined, Crimp**

**Material**

**Contact Body**—Brass

**Retention Spring**—Stainless steel

**Finish**

**Contact Body**—.000030 [0.00076] gold over .000050 [0.00127] nickel. Gold thickness controlled on socket O.D.

**Retention Spring**—Stainless steel

**Related Product Data**

**Application Tooling**—Pages 75-78



Pin

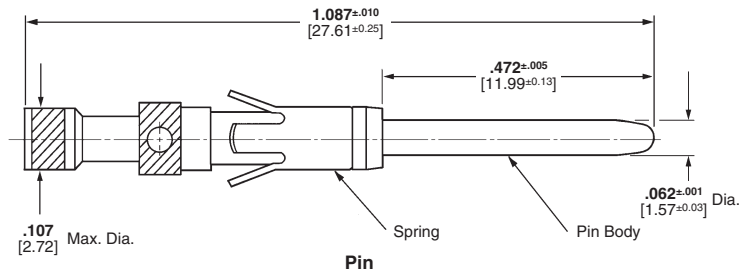

Socket

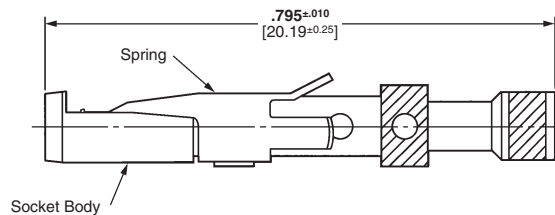

Socket

**Contact Size 16—Pin Diameter .062 [1.57] (Test Current, 13 Ampere)†**

| Wire Size Range | Ins. Dia. Range <sup>1</sup> | Tape Mounted Contact No. <sup>2</sup> |                       | Loose Piece Contact No. |                           | Contact Color Code    | Tooling Part No. <sup>**</sup>                     |   |                      |                                       |
|-----------------|------------------------------|---------------------------------------|-----------------------|-------------------------|---------------------------|-----------------------|--|---|----------------------|---------------------------------------|
|                 |                              | Pin                                   | Socket                | Pin                     | Socket                    |                       | Tape Mounted Dies for AMP-TAPETRONIC Machine 69875 | Loose Piece Die Set for 626 Pneumatic Tool System | Hand Tool            |                                       |
| 28-24           | 0.08-0.20                    | .035-.055<br>0.89-1.40                | 201611-4              | —                       | 201611-1 <sup>4</sup>     | 201613-1 <sup>5</sup> | Red/Red  | 90249-2   | 90230-1 <sup>7</sup> | 91538-1<br>or 601967-1                |
|                 |                              | .048-.065<br>1.22-1.65                | —                     | —                       | 201334-1 <sup>4</sup>     | 201332-1 <sup>5</sup> | Red/Red  |   | —                    | —                                     |
|                 |                              | .095-.110<br>2.41-2.79                | —                     | —                       | 202410-1 <sup>4</sup>     | 202411-1 <sup>5</sup> | Green  | —   | —                    | 601967-1                              |
| 24-20           | 0.2-0.6                      | .040-.062<br>1.02-1.57                | 201578-4              | —                       | 201578-1 <sup>4</sup>     | 201580-1 <sup>5</sup> | Yellow/Red   | 90249-2   | 90230-1 <sup>7</sup> | 91538-1<br>or 58541-1*<br>or 601967-1 |
|                 |                              | .055-.088<br>1.40-2.16                | 201330-6              | 201328-9                | 201330-1 <sup>4</sup>     | 201328-1 <sup>5</sup> | Yellow/Red   |   | —                    | —                                     |
| 18<br>(Two)     | 0.9-0.9<br>(Two)             | No. Ins. Support                      | —                     | —                       | 202725-1 <sup>4</sup>     | 202726-1 <sup>4</sup> | Blue   | —   | 90231-2 <sup>7</sup> | 91539-1<br>or 601967-1                |
| 18-16           | 0.8-1.4                      | .080-.105<br>2.03-2.67                | —                     | —                       | 202507-1 <sup>4</sup>     | 202508-1 <sup>5</sup> | —  | —   | —                    | 90136-1<br>or 601967-1                |
|                 |                              | No Ins. Support                       | 200336-6              | 200333-8                | 200336-1 <sup>4</sup>     | 200333-1 <sup>4</sup> | Blue/Blue  | 90250-1   | 90231-2 <sup>7</sup> | 91539-1<br>58541-1*<br>or 601967-1    |
| 14              | 2                            | No Ins. Support                       | 212618-2 <sup>3</sup> | —                       | 212618-1 <sup>3,6,†</sup> | —                     | Violet/Blue  | 90250-1   | 90231-2 <sup>7</sup> | 91539-1<br>58541-1*<br>or 601967-1    |
|                 |                              | No Ins. Support                       | 201570-2              | 201568-3                | 201570-1 <sup>4</sup>     | 201568-1 <sup>5</sup> | Violet/Blue  | —   | —                    | —                                     |

<sup>1</sup>Overall insulation crimp diameter, including crimp barrel, must not exceed .125 [3.18].

<sup>2</sup>For AMP-TAPETRONIC Machine No. 69875, order contacts by Tape Mounted Contact No., plus packaging code "IM REEL" (5000 parts per reel).

<sup>3</sup>Grounding pin is used to provide a make-first/break-last condition when mating and unmating connector halves.

<sup>4</sup>Use turret TH502 (1-601967-6) with hand tool 601967-1.

<sup>5</sup>Use turret TH501 (1-601967-5) with hand tool 601967-1.

<sup>6</sup>Pin length is .630±.005 [16.002±.127] on these two pins.

<sup>7</sup>Die Set requires "C" Head Adapter Part No. 318161-1; Adapter Holder Part No. 356304-1 (with ratchet) or 189928-1 (without); and Power Unit Part No. 189721-2 (hand actuated) or 189722-2 (foot actuated).

\*Commercial PRO-CRIMPER II Hand Tool for field repair use only. **Note:** Die Set can be adapted for use with the 626 Pneumatic Tool System.

\*\*There are power options available for these tools/dies. See Battery Powered Crimp tool Kit and SDE Electric Terminator on page 30.

†Does not use Hand Tool 91539-1 or 601967-1.

‡Single contact, free-air test current is not to be construed as contact rating current. Use only for testing. Refer to contact current carrying capability information on page 8.

**Insertion Tool Part No. 200893-2** (for insulation diameters .070 [1.78] or less).

**Extraction Tool Part No. 305183.**

**Note:** All part numbers are RoHS compliant.



**Signal Contacts** (Continued)

**Size 20 DF, Crimp, Snap-In**

**Contact Size**—20  
**Pin Diameter**—.040 [1.02]  
**\*See Product Spec 108-40005**



Pin



Socket

**Material**

**Pin Body**—Brass  
**Socket**—Phosphor bronze

**Contact Finish**

- A**—Select gold flash over nickel on entire contact, with additional .000030 [0.00076] gold on mating end
  - B**—Duplex plated .000030 [0.00076] gold on mating end, tin on termination end, with entire contact nickel underplated
  - C**—Gold flash over nickel on entire contact
  - D**—Duplex plated gold flash on mating end, tin on termination end, with entire contact nickel underplated
- Insertion/Extraction Tool **Part No. 91285-1**  
 Instruction Sheet—408-9404  
 This tool includes interchangeable tips to Insert/Extract:  
 Size 22, 28-22 AWG [0.08-0.03mm<sup>2</sup>] Crimp Contacts  
 Size 20, 28-20 AWG [0.08-0.6mm<sup>2</sup>] Crimp and Solder Cup Contacts  
 Size 20, Posted Contacts

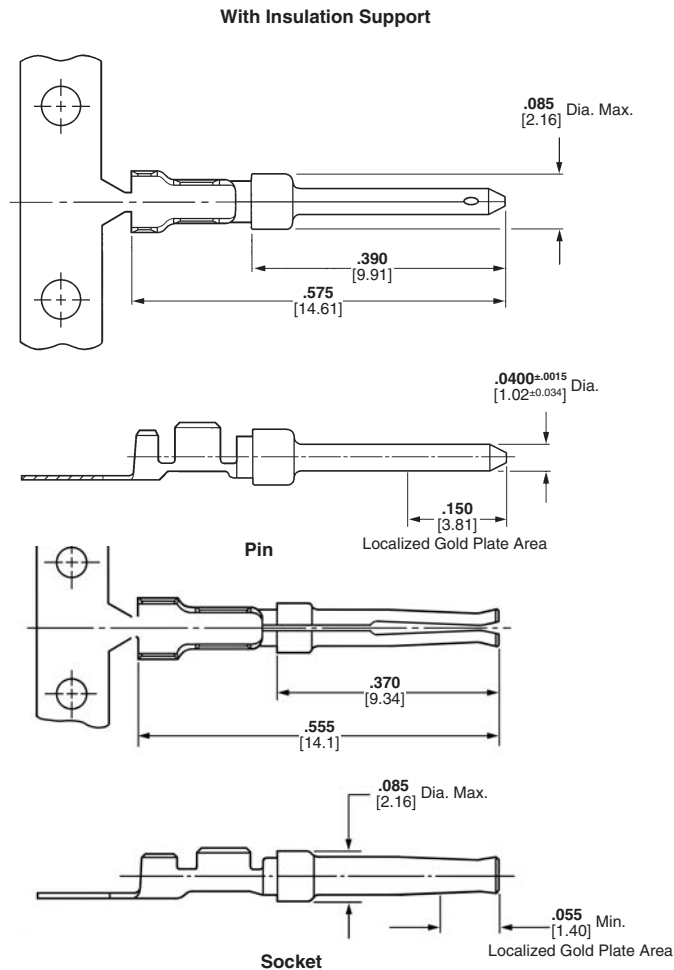

| Wire Size Range                       | Ins. Dia. Max. | Contact Finish Code | Contact Part Nos. |             |              |             | Tooling**  |           | Color Code (Loose Piece) |
|---------------------------------------|----------------|---------------------|-------------------|-------------|--------------|-------------|--|-----------|--------------------------|
|                                       |                |                     | Pin               |             | Socket       |             | Strip Form Applicator††  | Hand Tool |                          |
|                                       |                |                     | Strip Form        | Loose Piece | Strip Form   | Loose Piece |  |           |                          |
| 28-24 AWG [0.08-0.2 mm <sup>2</sup> ] | .040           | A                   | 66507-3◆          | 66507-9◆    | 66505-3◆     | 66505-9◆    | 466423-□††◆<br>or 466901-1††◆<br>or 1016015-1††◆                   | 91503-1†◆ | Blue Dot                 |
|                                       |                | B                   | 1658540-1◆        | 1658540-5◆  | 1658538-2◆   | —           |  |           |                          |
|                                       |                | C                   | 66507-4◆          | 1-66507-0◆  | 66505-4◆     | 1-66505-0◆  |  |           |                          |
|                                       |                | D                   | 1658540-5◆        | 1658540-2◆  | 1658538-3◆   | 1658538-1◆  |  |           |                          |
| 26-22 AWG [0.12-0.4 mm <sup>2</sup> ] | .060           | A                   | 66682-2◆          | 66682-4◆    | 66683-2◆     | 66683-4◆    | 466758-2††◆<br>or 466963-1††◆<br>or 567804-1††◆                    | 91549-1†◆ | Black Dot                |
|                                       |                | B                   | 5066682-9◆        | —           | 1-5066683-0◆ | —           |  |           |                          |
|                                       |                | C                   | —                 | —           | —            | —           |  |           |                          |
|                                       |                | D                   | 5066682-6◆        | —           | 5066683-7◆   | —           |  |           |                          |
| 24-20 AWG [0.2-0.6 mm <sup>2</sup> ]  | .050           | A                   | 745254-2◆         | 745254-6◆   | 745253-2◆    | 745253-6◆   | 466968-1††◆<br>or 567036-□††◆<br>or 567849-1††◆                    | 91525-1†◆ | Yellow Dot               |
|                                       |                | B                   | 1658544-2◆        | 1658544-1◆  | 1658543-2◆   | 1658543-1◆  |  |           |                          |
|                                       |                | C                   | 745254-3◆         | 745254-7◆   | 745253-3◆    | 745253-7◆   |  |           |                          |
|                                       |                | D                   | 1658544-3◆        | —           | 1658543-3◆   | —           |  |           |                          |
| 24-20 AWG [0.2-0.6 mm <sup>2</sup> ]  | .060           | A                   | 66506-3◆          | 66506-9◆    | 66504-3◆     | 66504-9◆    | 466422-□††◆<br>or 466900-1††◆<br>or 567801-1††◆<br>or 1016002-1††◆ | 91503-1†◆ | Red Dot                  |
|                                       |                | B                   | 1658539-1◆        | 1658539-3◆  | 1658537-3◆   | 1658537-4◆  |  |           |                          |
|                                       |                | C                   | 66506-4◆          | 1-66506-0◆  | 66504-4◆     | 1-66504-0◆  |  |           |                          |
|                                       |                | D                   | 1658539-2◆        | 1658539-4◆  | 1658537-1◆   | 1658537-2◆  |  |           |                          |

†To use with the 626 Pneumatic Tool System: remove the crimping head from the Straight Action Hand Tool (SAHT) Assembly, order SAHT Adapter **Part No. (Call Technical Support at 800-522-6752)**, Adapter Holder **Part No. 356304-1** (with ratchet) or **189928-1** (without), and Power Unit **Part No. 189721-1** (hand actuated) or **189722-1** (foot actuated).

††For complete information on AMP Strip Form Applicators for fully automatic and semiautomatic machines, contact Technical Support: 1-800-522-6752.

**Note:** Commercial PRO-CRIMPER II Maintenance and Repair Hand Tool for Wire Size 28-24 AWG [0.08-0.2mm<sup>2</sup>] (Ins. Dia. Max. .040 [1.02]), and Wire Size 24-20 AWG [0.2-0.6mm<sup>2</sup>] (Ins. Dia. Max. .060 [1.52])—**Part No. 58448-2**.

**Note:** Die Set **Part No. 58448-3** can be adapted for use with the 626 Pneumatic Tool System.

\*\*There are power options available for these tools/dies. See Battery Powered Crimp tool Kit and SDE Electric Terminator on page 30.

**Note:** All part numbers are RoHS compliant except: ◆ Indicates non-RoHS compliant.

**Signal Contacts** (Continued)

**Size 20 DF, Crimp, Snap-In**  
(Continued)

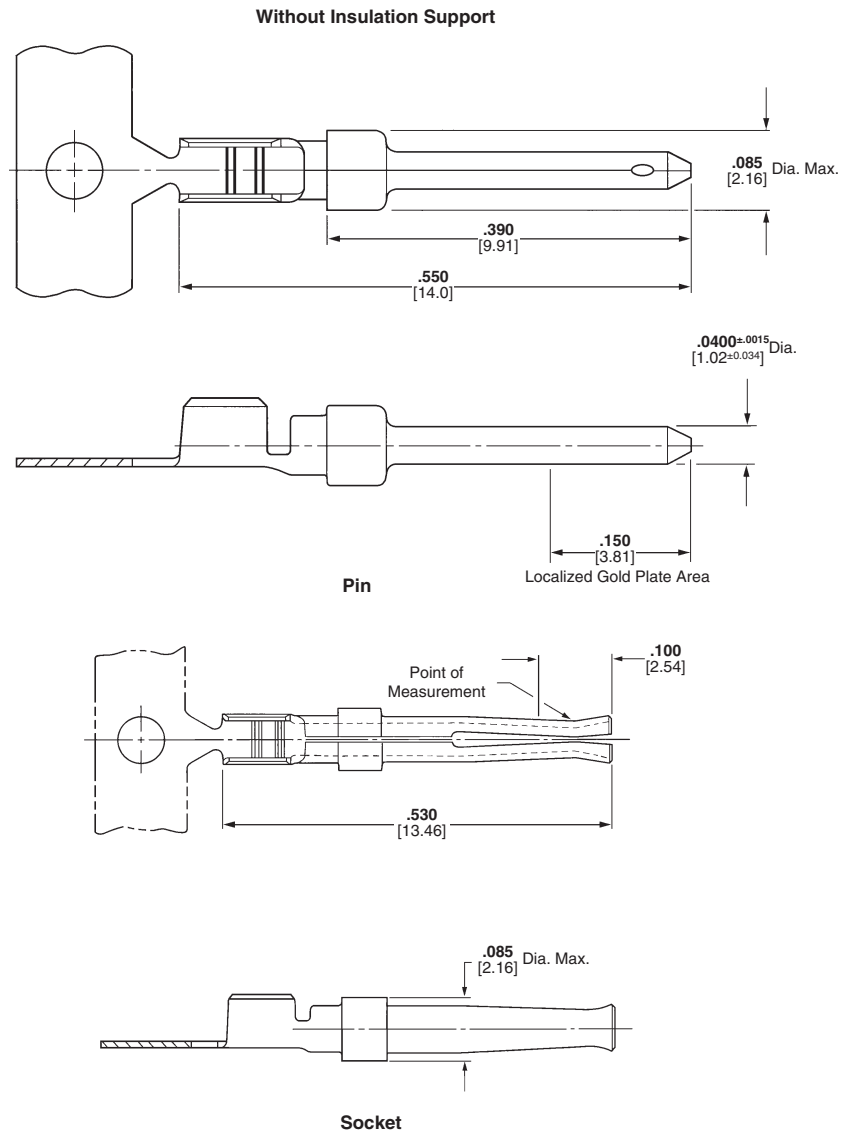
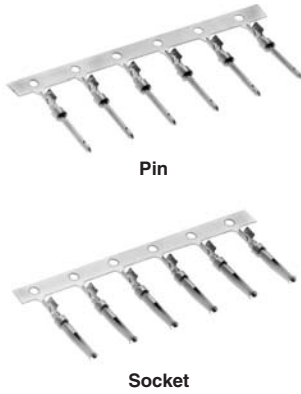

| Wire Size Range                          | Ins. Dia. Max. | Contact Finish Code | Contact Part Nos. |             |             |             | Tooling**             |           | Color Code (Loose Piece) |
|--|----------------|---------------------|-------------------|-------------|-------------|-------------|-----------------------|-----------|--------------------------|
|  |                |                     | Pin               |             | Socket      |             | Strip Form Applicator | Hand Tool |                          |
|  |                |                     | Strip Form        | Loose Piece | Strip Form  | Loose Piece |                       |           |                          |
| 28-24 AWG<br>[0.08-0.2 mm <sup>2</sup> ] | .068<br>1.73   | A                   | 205310-2♦         | —           | 205311-3♦   | —           | ††                    | —         | —                        |
|  |                | C                   | —                 | —           | —           | —           |                       |           |                          |
| 24-20 AWG<br>[0.2-0.6 mm <sup>2</sup> ]  | .068<br>1.73   | A                   | 205202-2♦         | —           | 205201-3♦   | 205201-5♦   | ††                    | 91548-1♦  | Red Dot                  |
|  |                | C                   | 205202-6♦         | 205202-7♦   | 205201-6♦   | 205201-7♦   |                       |           |                          |
| 22-18 AWG<br>[0.4-0.8 mm <sup>2</sup> ]  | .068<br>1.73   | A                   | 745229-2♦         | 745229-4♦   | 745230-2♦   | 745230-4♦   | ††                    | 91513-1♦  | Green Dot                |
|  |                | B                   | 1-745229-1♦       | —           | 1-745230-1♦ | 1-745230-3♦ |                       |           |                          |
|  |                | C                   | 745229-5♦         | 745229-7♦   | 745230-5♦   | 745230-7♦   |                       |           |                          |
|  |                | D                   | —                 | —           | 745230-8♦   | —           |                       |           |                          |

††For complete information on AMP Strip Form Applicators for fully automatic and semiautomatic machines, contact Technical Support: 1-800-522-6752.

**Note:** Wire insulation diameter is limited by the connector housing cavity and clearance for the insertion/extraction tool.

\*\*There are power options available for these tools/dies. See Battery Powered Crimp tool Kit and SDE Electric Terminator on page 30.

**Note:** All part numbers are RoHS compliant except: ♦ Indicates non-RoHS compliant.



**Signal Contacts** (Continued)

**Size 20 DF, Solder, Snap-In**

Contact Size—20

\*See Product Spec 108-40005



Pin



Socket

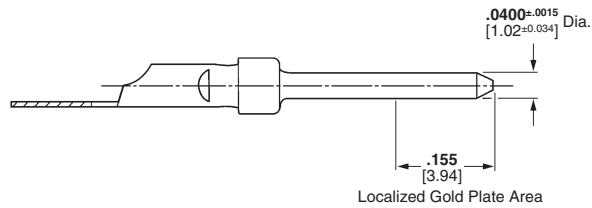
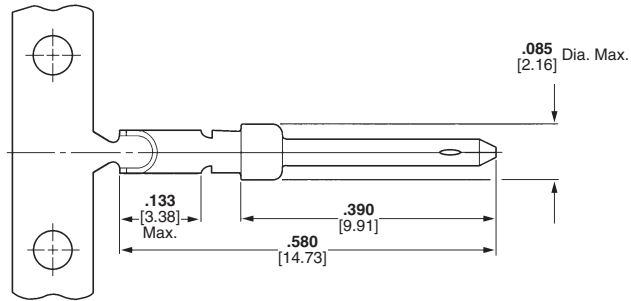

Pin

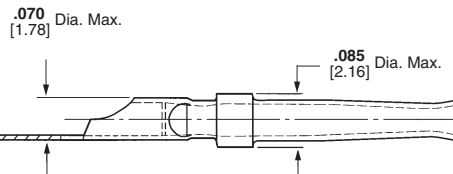
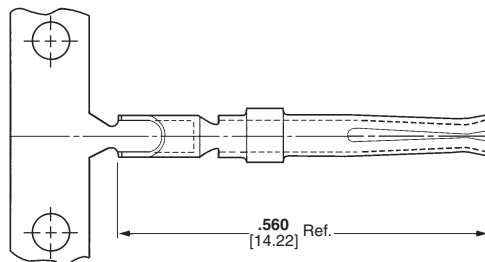

Socket

**Material**

Pin—Brass

Socket—Phosphor bronze

**Contact Finish**

Gold flash over nickel on entire contact, with additional .000030 [0.00076] gold on mating end

Contacts to be soldered to wire before being inserted into housing.  
18 AWG [0.8-0.9 mm<sup>2</sup>] Max. Wire

| Strip Form Contact No. |         | Loose Piece Contact No. |         |
|------------------------|---------|-------------------------|---------|
| Pin                    | Socket  | Pin                     | Socket  |
| 66570-2                | 66569-2 | 66570-3                 | 66569-3 |

Note: All part numbers are RoHS compliant.



Компания «ЭлектроПласт» предлагает заключение долгосрочных отношений при поставках импортных электронных компонентов на взаимовыгодных условиях!

Наши преимущества:

- Оперативные поставки широкого спектра электронных компонентов отечественного и импортного производства напрямую от производителей и с крупнейших мировых складов;
- Поставка более 17-ти миллионов наименований электронных компонентов;
- Поставка сложных, дефицитных, либо снятых с производства позиций;
- Оперативные сроки поставки под заказ (от 5 рабочих дней);
- Экспресс доставка в любую точку России;
- Техническая поддержка проекта, помощь в подборе аналогов, поставка прототипов;
- Система менеджмента качества сертифицирована по Международному стандарту ISO 9001;
- Лицензия ФСБ на осуществление работ с использованием сведений, составляющих государственную тайну;
- Поставка специализированных компонентов (Xilinx, Altera, Analog Devices, Intersil, Interpoint, Microsemi, Aeroflex, Peregrine, Syfer, Eurofarad, Texas Instrument, Miteq, Cobham, E2V, MA-COM, Hittite, Mini-Circuits, General Dynamics и др.);

Помимо этого, одним из направлений компании «ЭлектроПласт» является направление «Источники питания». Мы предлагаем Вам помощь Конструкторского отдела:

- Подбор оптимального решения, техническое обоснование при выборе компонента;
- Подбор аналогов;
- Консультации по применению компонента;
- Поставка образцов и прототипов;
- Техническая поддержка проекта;
- Защита от снятия компонента с производства.



#### Как с нами связаться

**Телефон:** 8 (812) 309 58 32 (многоканальный)

**Факс:** 8 (812) 320-02-42

**Электронная почта:** [org@eplast1.ru](mailto:org@eplast1.ru)

**Адрес:** 198099, г. Санкт-Петербург, ул. Калинина, дом 2, корпус 4, литера А.