

THIS DRAWING IS UNPUBLISHED. RELEASED FOR PUBLICATION 20
 © COPYRIGHT 20 BY - ALL RIGHTS RESERVED.

LOC	DIST	REVISIONS					
GP	00	P	LTR	DESCRIPTION	DATE	DWN	APVD
		B		REVISED PER ECO-11-006746	04/APR/11	ECC	PJB
		C		REVISED PER ECR-11-013082	23/JUN/11	ECC	PJB
		E		ECR-12-019784	19NOV2012	TB	DM

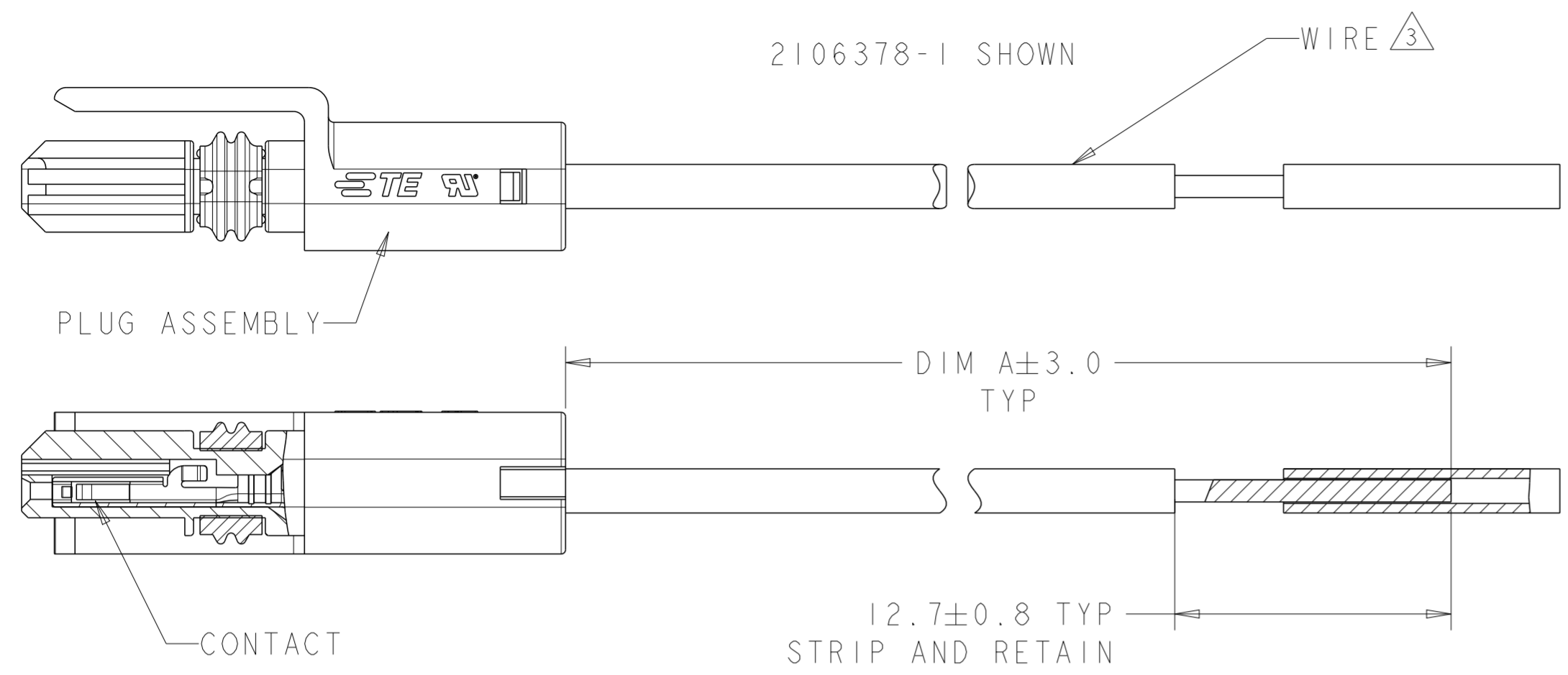

- ⚠ MATERIALS AND FINISH:
 - CONTACTS: COPPER ALLOY
 - FINISH: TIN IN CONTACT AREA OVER NICKEL UNDERPLATE
 - WIRE: 18 AWG, STRANDED, UL 1007 STYLE
- 2. MUST COMPLY WITH DIRECTIVE 2002/95/EC (ROHS)
- ⚠ REFERENCE CHART FOR SPECIFIC WIRE COLOR/POSITION.
- ⚠ CONTACTS 0.000381 THK GOLD STRIPE PRE-PLATED STOCK, REF.

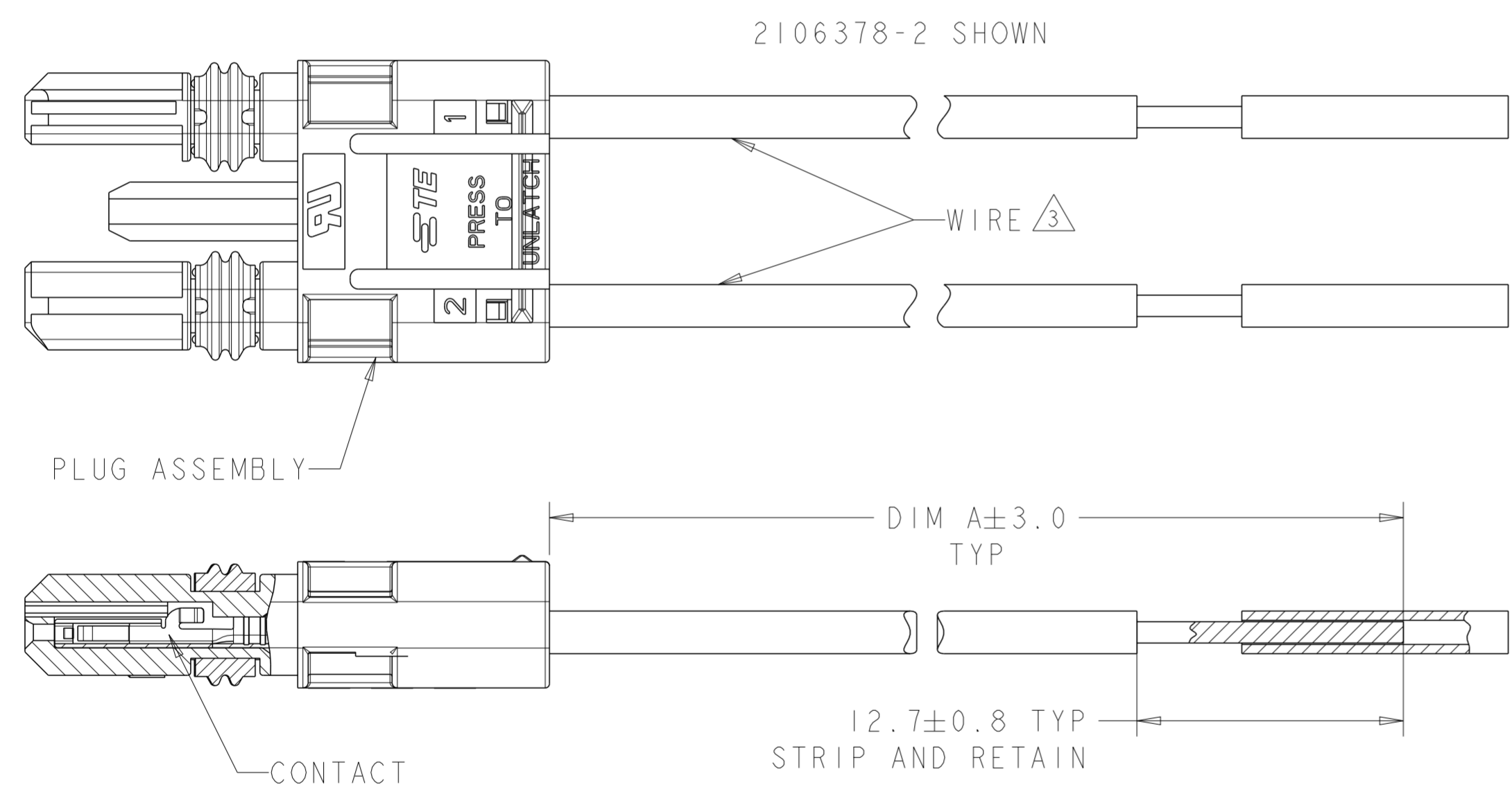

⚠	304.8	20 AWG	4	3-2106378-3
⚠	304.8	20 AWG	2	3-2106378-1
⚠	101.6	20 AWG	2	2-2106378-8
	381.0	18 AWG	2	2-2106378-6
	304.8	24 AWG	4	2-2106378-5
	304.8	24 AWG	3	2-2106378-4
	304.8	24 AWG	2	2-2106378-3
	101.6	24 AWG	4	2-2106378-2
	101.6	24 AWG	3	2-2106378-1
	101.6	24 AWG	2	2-2106378-0
	304.8	22 AWG	4	1-2106378-9
	304.8	22 AWG	3	1-2106378-8
	304.8	22 AWG	2	1-2106378-7
	101.6	22 AWG	4	1-2106378-6
	101.6	22 AWG	3	1-2106378-5
	101.6	22 AWG	2	1-2106378-4
	304.8	20 AWG	4	1-2106378-3
	304.8	20 AWG	3	1-2106378-2
	304.8	20 AWG	2	1-2106378-1
	101.6	20 AWG	4	1-2106378-0
	101.6	20 AWG	3	2106378-9
	101.6	20 AWG	2	2106378-8
	304.8	18 AWG	4	2106378-7
	304.8	18 AWG	3	2106378-6
	304.8	18 AWG	2	2106378-5
	101.6	18 AWG	4	2106378-4
	101.6	18 AWG	3	2106378-3
	101.6	18 AWG	2	2106378-2
	101.6	18 AWG	1	2106378-1
DIM A	WIRE SIZE	POSN	PART NO.	

WIRE COLOR CHART

4	-	-	-	BLUE	-	-	BLUE	-	-	BLUE	-	-	BLUE	-	-	BLUE	-	-	BLUE	-	-	BLUE	-	-	BLUE	-
3	-	-	WHITE	WHITE	-	WHITE	WHITE	-	WHITE	WHITE	-	WHITE	WHITE	-	WHITE	WHITE	-	WHITE	WHITE	-	WHITE	WHITE	-	WHITE	WHITE	-
2	-	RED	RED	RED	RED	RED	RED	RED	RED	RED	RED	RED	RED	RED	RED	RED	RED	RED	RED	RED	RED	RED	RED	RED	RED	BLACK
1	BLACK	BLACK	BLACK	BLACK	BLACK	BLACK	BLACK	BLACK	BLACK	BLACK	BLACK	BLACK	BLACK	BLACK	BLACK	BLACK	BLACK	BLACK	BLACK	BLACK	BLACK	BLACK	BLACK	BLACK	BLACK	RED
POS	-1	-2	-3	-4	-5	-6	-7	-8	-9	-10	-11	-12	-13	-14	-15	-16	-17	-18	-19	-20	-21	-22	-23	-24	-25	-26

4	-	-	-	-	-	-	BLUE
3	-	-	-	-	-	-	WHITE
2	-	RED	-	-	RED	-	RED
1	-	BLACK	-	-	BLACK	-	BLACK
POS	-27	-28	-29	-30	-31	-32	-33

THIS DRAWING IS A CONTROLLED DOCUMENT.

DWN R BROWN 16APR2009
 CHK M MOSTOLLER 16APR2009
 APVD -

TE Connectivity

CABLE ASSEMBLY, PLUG, SLIMSEAL SSL CONNECTOR

SIZE: A2 CAGE CODE: 00779 DRAWING NO: C-2106378 RESTRICTED TO: -

MATERIAL: - DIMENSIONS: mm TOLERANCES UNLESS OTHERWISE SPECIFIED: 0 PLC ±, 1 PLC ±0.2, 2 PLC ±, 3 PLC ±, 4 PLC ±, ANGLES ±, FINISH ±

PRODUCT SPEC: - APPLICATION SPEC: - WEIGHT: - SCALE: 1:1 SHEET 1 OF 3 REV E

THIS DRAWING IS UNPUBLISHED. RELEASED FOR PUBLICATION 20
 © COPYRIGHT 20 BY - ALL RIGHTS RESERVED.

LOC	DIST	REVISIONS					
GP	00	P	LTR	DESCRIPTION	DATE	DWN	APVD
		-		SEE SHEET 1	-	-	-

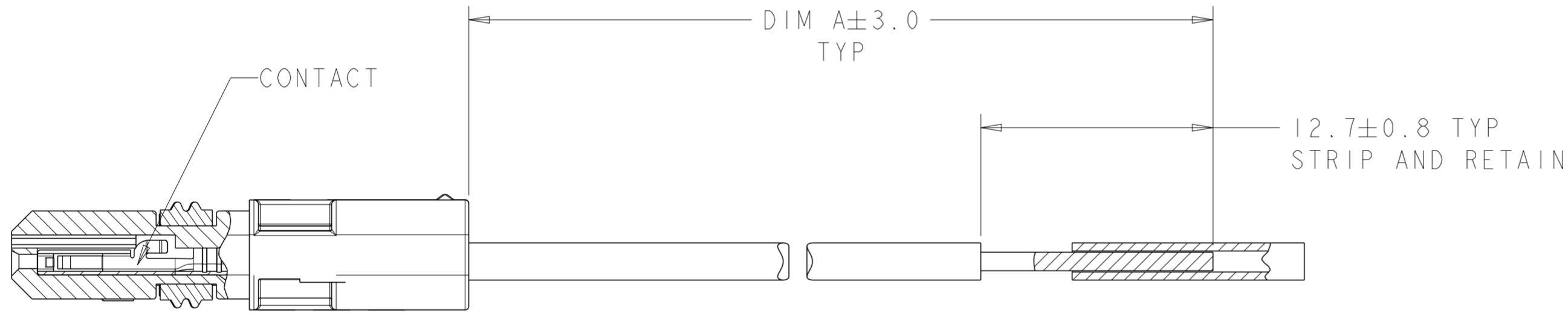
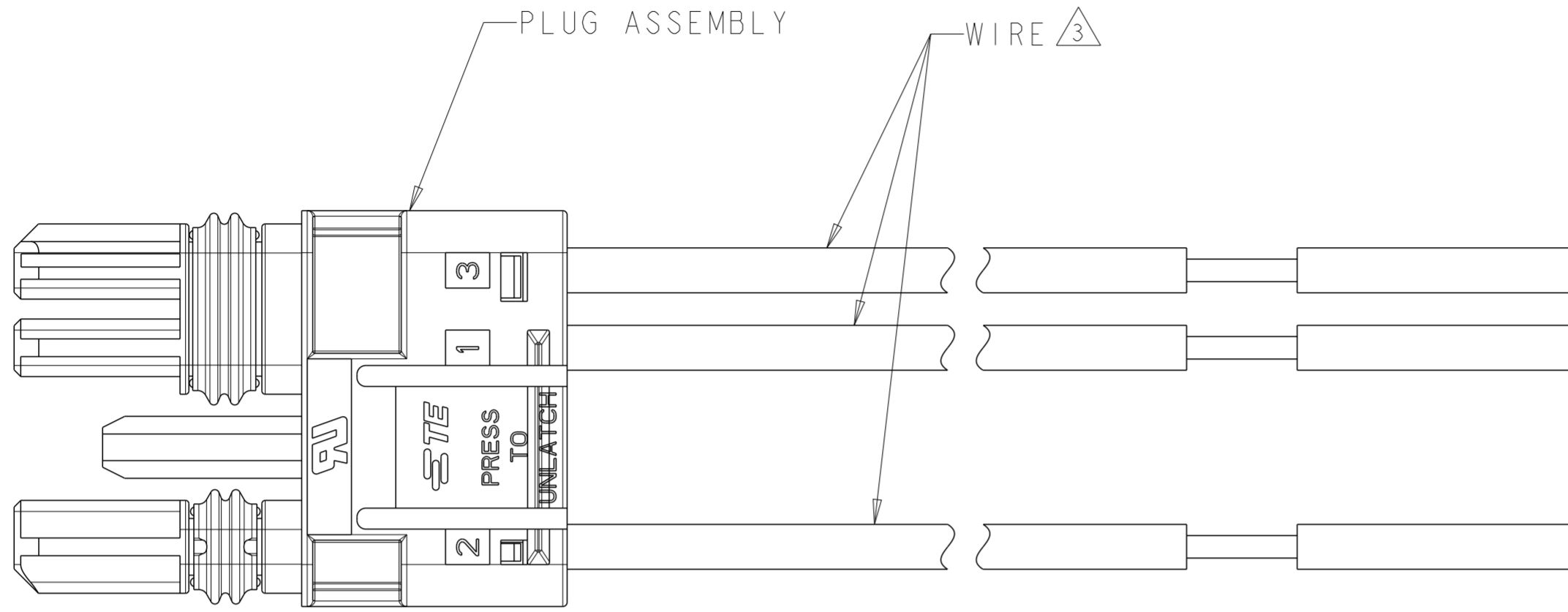

2106378-3 SHOWN

THIS DRAWING IS A CONTROLLED DOCUMENT.		DWN R BROWN 16APR2009	 TE Connectivity	
DIMENSIONS: mm		CHK M MOSTOLLER 16APR2009		
TOLERANCES UNLESS OTHERWISE SPECIFIED:		APVD -	NAME CABLE ASSEMBLY, PLUG, SLIMSEAL SSL CONNECTOR	
0 PLC ± 1 PLC ±0.2 2 PLC ± 3 PLC ± 4 PLC ±		PRODUCT SPEC -	SIZE A200779	
MATERIAL -		APPLICATION SPEC -	CAGE CODE C-2106378	
FINISH -		WEIGHT -	DRAWING NO -	
		CUSTOMER DRAWING	SCALE 1:1	SHEET 2 OF 3
				REV E

THIS DRAWING IS UNPUBLISHED. RELEASED FOR PUBLICATION 20
 © COPYRIGHT 20 BY - ALL RIGHTS RESERVED.

LOC	DIST	REVISIONS					
GP	00	P	LTR	DESCRIPTION	DATE	DWN	APVD
		-		SEE SHEET 1	-	-	-

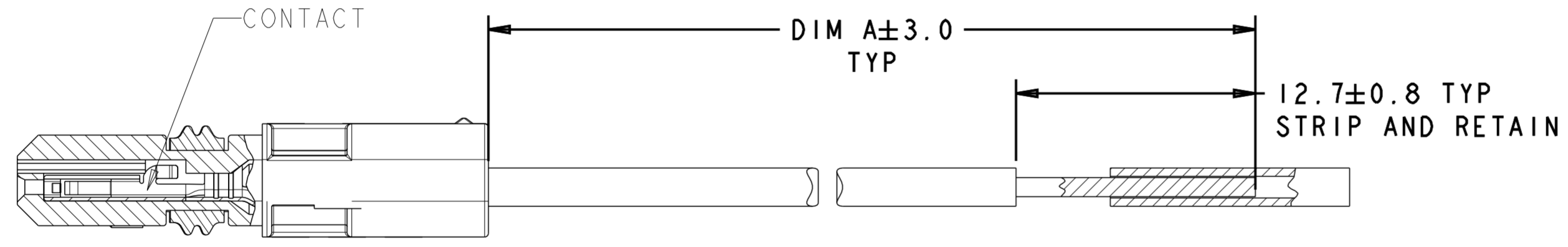
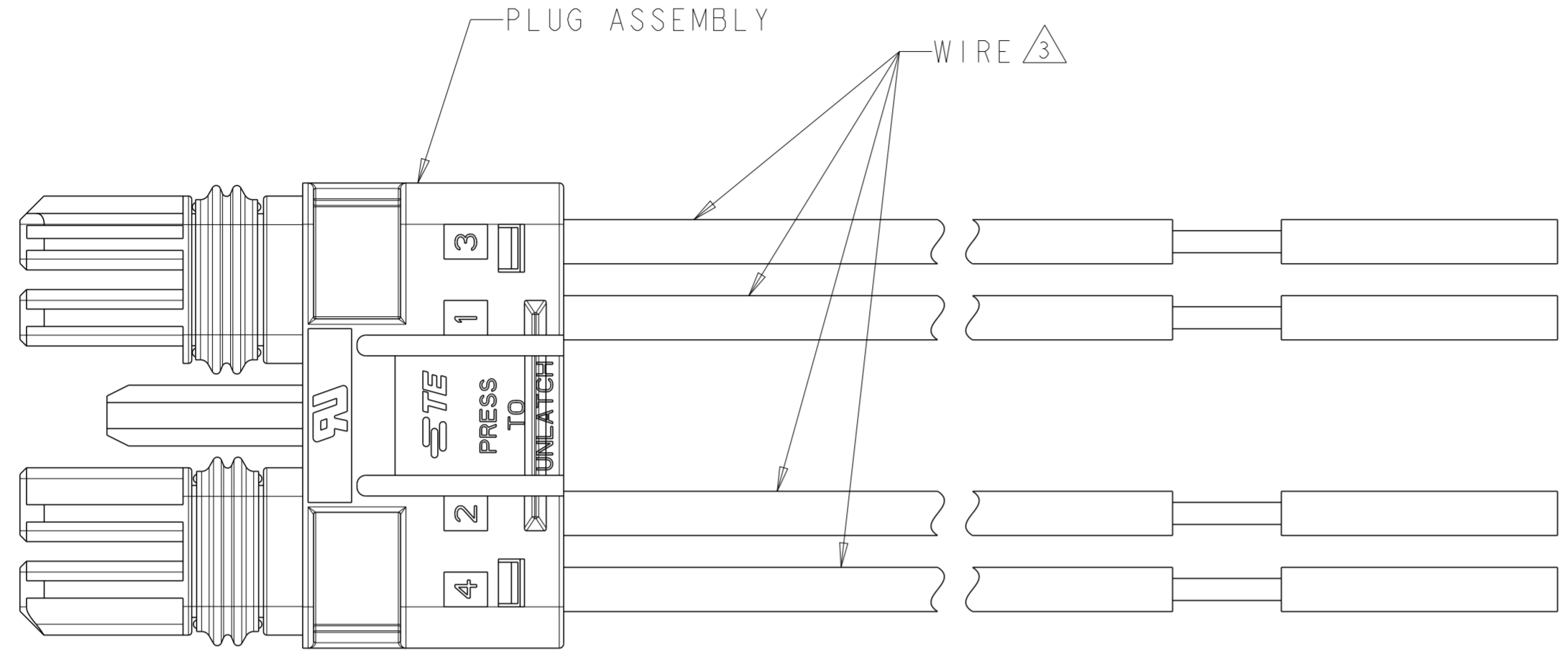

2106378-4 SHOWN

THIS DRAWING IS A CONTROLLED DOCUMENT.		DWN R BROWN 16APR2009	TE Connectivity	
DIMENSIONS: mm		CHK M MOSTOLLER 16APR2009		
TOLERANCES UNLESS OTHERWISE SPECIFIED:		APVD -	NAME CABLE ASSEMBLY, PLUG, SLIMSEAL SSL CONNECTOR	
0 PLC ±-		PRODUCT SPEC -	SIZE A200779	
1 PLC ±0.2		APPLICATION SPEC -	CAGE CODE C-2106378	DRAWING NO -
2 PLC ±-		WEIGHT -	RESTRICTED TO -	
3 PLC ±-		CUSTOMER DRAWING	SCALE 1:1	SHEET 3 OF 3
4 PLC ±-				REV E
ANGLES ±-				
FINISH				



Компания «ЭлектроПласт» предлагает заключение долгосрочных отношений при поставках импортных электронных компонентов на взаимовыгодных условиях!

Наши преимущества:

- Оперативные поставки широкого спектра электронных компонентов отечественного и импортного производства напрямую от производителей и с крупнейших мировых складов;
- Поставка более 17-ти миллионов наименований электронных компонентов;
- Поставка сложных, дефицитных, либо снятых с производства позиций;
- Оперативные сроки поставки под заказ (от 5 рабочих дней);
- Экспресс доставка в любую точку России;
- Техническая поддержка проекта, помощь в подборе аналогов, поставка прототипов;
- Система менеджмента качества сертифицирована по Международному стандарту ISO 9001;
- Лицензия ФСБ на осуществление работ с использованием сведений, составляющих государственную тайну;
- Поставка специализированных компонентов (Xilinx, Altera, Analog Devices, Intersil, Interpoint, Microsemi, Aeroflex, Peregrine, Syfer, Eurofarad, Texas Instrument, Miteq, Cobham, E2V, MA-COM, Hittite, Mini-Circuits, General Dynamics и др.);

Помимо этого, одним из направлений компании «ЭлектроПласт» является направление «Источники питания». Мы предлагаем Вам помощь Конструкторского отдела:

- Подбор оптимального решения, техническое обоснование при выборе компонента;
- Подбор аналогов;
- Консультации по применению компонента;
- Поставка образцов и прототипов;
- Техническая поддержка проекта;
- Защита от снятия компонента с производства.



Как с нами связаться

Телефон: 8 (812) 309 58 32 (многоканальный)

Факс: 8 (812) 320-02-42

Электронная почта: org@eplast1.ru

Адрес: 198099, г. Санкт-Петербург, ул. Калинина, дом 2, корпус 4, литера А.