

**DLP-RFID-
LP8C**
LEAD-FREE

8-Channel Reader/Writer

FEATURES:

- ISO 15693, 18000-3, 14443*, Tag-it™ HF-I Compatible
- Can read the UID/SID of up to 15 Tags Simultaneously
- 13.56MHz Reader/Writer
- 8 Channels for External Antenna Connections
- FCC/IC/CE Modular Approvals in Place
- USB Port Powered from Windows, CE or Linux PC
- Both USB and RS232 Interfaces Provided
- USB Interface; No Driver Development Required for Windows, CE or Linux PC
- Operating Temperatures: 0°C to 70°C
- Dimensions: (L x W x H) 4.36" x 3.32" x 0.6"

APPLICATIONS INCLUDE:

- Real-Time Security
- Personal Identification
- Pharmaceutical Tracking
- Inventory/Asset Management & Tracking
- Library/Book Management & Tracking
- Baggage Tagging
- Sports Event Timing

1.0 INTRODUCTION

The DLP-RFID-LP8C is a low-cost, USB-powered module for reading from and writing to ISO 15693, ISO 18000-3, ISO14443* and Tag-it™ intelligent RFID transponder tags via up to eight external antennas. It has the ability to both read and write up to 256 bytes of data in addition to reading the unique identifier (UID/SID). All of the DLP-RFID-LP8C's electronics reside on a single, compact PCB; and all operational power is taken from the host Windows/Windows CE/Linux PC via the USB interface. Up to eight external antennas can be connected via standard SMA connectors.

* - Contact DLP Design for ISO14443 implementation information.

2.0 APPLICATION DEVELOPMENT

Demonstration source code written in Visual C++ is provided with the purchase of a DLP-RFID-LP8C module that demonstrates the communications protocol. Using the Virtual COM Port USB drivers, the DLP-RFID-LP8C appears to the host PC (Windows, Linux, Mac) as an RS232 port.

3.0 MECHANICAL DIMENSIONS IN INCHES (MM)

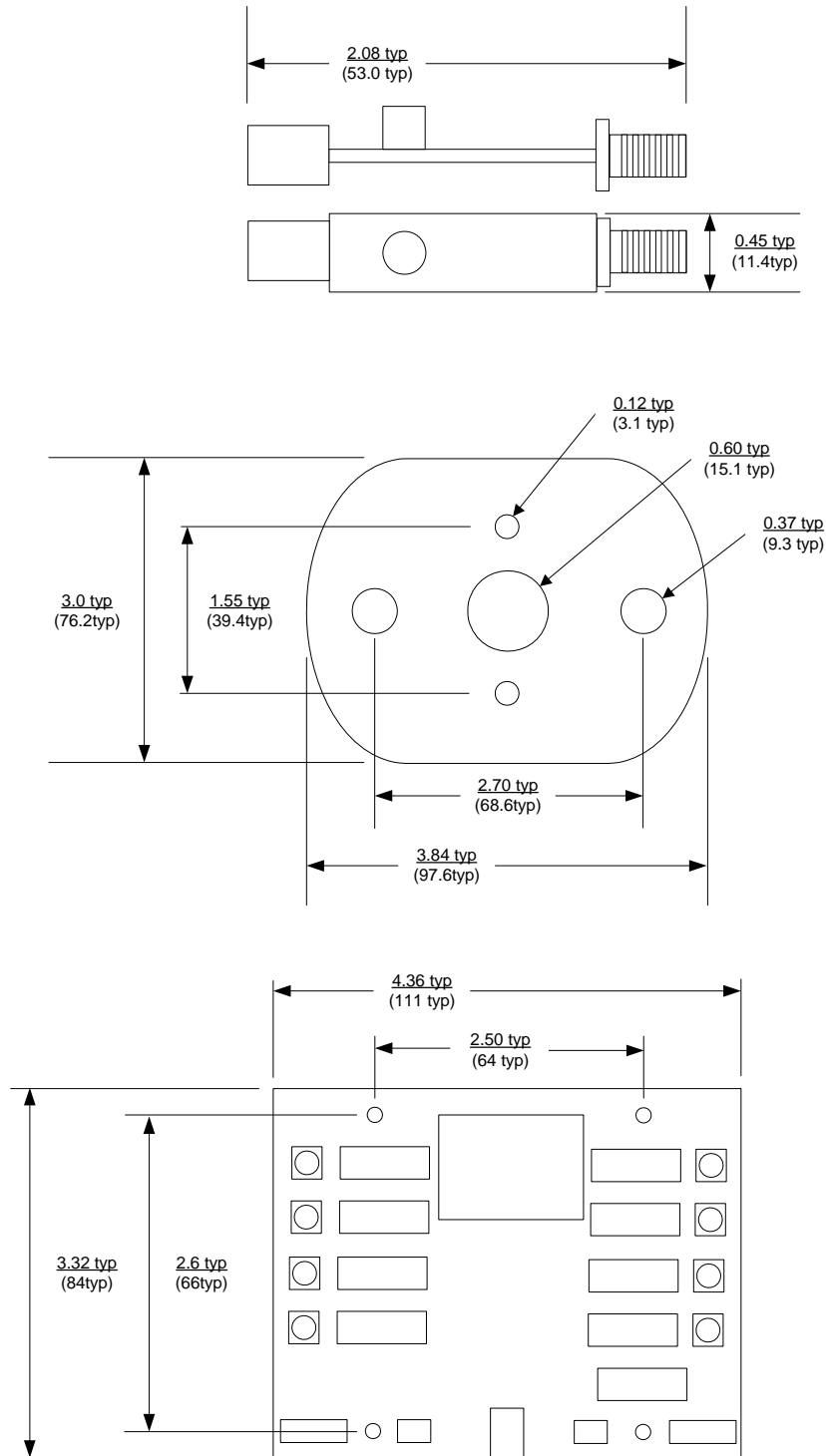

4.0 REGULATORY AGENCY CONSIDERATIONS

4.1 AGENCY IDENTIFICATION NUMBERS

Compliance with the appropriate regulatory agencies is essential in the deployment of all intentional radiators. DLP Design has obtained modular approval for this RF product such that an OEM need only meet a few basic requirements in order to utilize their end product under this approval. Corresponding agency identification numbers are listed below:

<u>PART NUMBER</u>	<u>US/FCC</u>	<u>CAN/IC</u>
DLP-RFID-LP8C	SX90LP8C	5675A-0LP8C

4.2 EXTERNAL ANTENNAS

The DLP-RFID1-LP8C is approved for use with selected external antennas. Connection is made via reverse-polarity SMA connectors.

Two different antennas are available from DLP Design: the **DLP-FANT** and the **DLP-RFID-ANT**.



DLP-FANT



DLP-RFID-ANT

The DLP-FANT ferrite-based antenna provides a compact footprint for space-constrained applications and provides up to a 1.25-inch read range.

The DLP-FANT requires a coax cable with a reverse-polarity SMA connector at one end for connection to the DLP-RFID-LP8C reader. This coax cable is available in a 3-foot length from DLP Design under part number DLP-COAX1.

The DLP-RFID-ANT ships with an attached 15-foot coax cable with a reverse-polarity SMA connector and provides up to 4 inches of read range.

4.3 FCC/IC REQUIREMENTS FOR MODULAR APPROVAL

Any changes or modifications to the DLP-RFID-LP8C's printed circuit board could void the user's authority to operate the equipment. Operation of an unapproved antenna could void the user's authority to operate the equipment.

4.4 WARNINGS

Operation is subject to the following two conditions: (1) This device may not cause harmful interference; and (2) this device must accept any interference received, including interference that may cause undesirable operation.

To reduce potential radio interference with other users, the antenna type and its gain should be so chosen that the equivalent isotropically-radiated power (e.i.r.p.) is not more than that permitted for successful communication.

This device is intended for use under the following conditions:

1. The transmitter module may not be co-located with any other transmitter or antenna; and,
2. The module is approved using the FCC "unlicensed modular transmitter approval" method.

As long as these two conditions are met, further transmitter testing will not be required. However, the OEM integrator is still responsible for testing their end product for any additional compliance measures necessitated by the installation of this module (i.e. digital device emissions, PC peripheral requirements, etc.).

Note: In the event that these conditions cannot be met (i.e. co-location with another transmitter), then the FCC authorization is no longer valid, and the corresponding FCC ID may *not* be used on the final product. Under these circumstances, the OEM integrator will be responsible for re-evaluating the end product (including the transmitter) and obtaining a separate FCC authorization.

4.5 OEM PRODUCT LABELING

The final end product must be labeled in a visible area with the following text:

"Contains TX FCC ID: SX90LP8C"

4.6 RF EXPOSURE

In order to comply with FCC RF exposure-compliance requirements, the antenna used for this transmitter must not be co-located or operating in conjunction with any other antenna or transmitter.

4.7 ADDITIONAL INFORMATION FOR OEM INTEGRATORS

The end user should NOT be provided with any instructions on how to remove or install the DLP-RFID-LP8C. This device has been pre-certified to operate with the antenna models listed below:

- DLP Design Large Loop Antenna
- DLP Design Small Loop Antenna
- DLP Design Ferrite Antenna

5.0 DISCLAIMER

Neither the whole nor any part of the information contained herein nor the product described in this datasheet may be adapted or reproduced in any material or electronic form without the prior written consent of the copyright holder.

This product and its documentation are supplied on an as-is basis, and no warranty as to their suitability for any particular purpose is either made or implied. DLP Design will not accept any claim for damages whatsoever arising as a result of use or failure of this product. Your statutory rights are not affected.

This product or any variant of it is not intended for use in any medical appliance, device or system in which the failure of the product might reasonably be expected to result in personal injury.

This document provides preliminary information that may be subject to change without notice.

6.0 CONTACT INFORMATION

DLP Design, Inc.
1605 Roma Lane
Allen, TX 75013

Phone: 469-964-8027
Fax: 415-901-4859
Email: support@dlpdesign.com
Internet: <http://www.dlpdesign.com>



Компания «ЭлектроПласт» предлагает заключение долгосрочных отношений при поставках импортных электронных компонентов на взаимовыгодных условиях!

Наши преимущества:

- Оперативные поставки широкого спектра электронных компонентов отечественного и импортного производства напрямую от производителей и с крупнейших мировых складов;
- Поставка более 17-ти миллионов наименований электронных компонентов;
- Поставка сложных, дефицитных, либо снятых с производства позиций;
- Оперативные сроки поставки под заказ (от 5 рабочих дней);
- Экспресс доставка в любую точку России;
- Техническая поддержка проекта, помощь в подборе аналогов, поставка прототипов;
- Система менеджмента качества сертифицирована по Международному стандарту ISO 9001;
- Лицензия ФСБ на осуществление работ с использованием сведений, составляющих государственную тайну;
- Поставка специализированных компонентов (Xilinx, Altera, Analog Devices, Intersil, Interpoint, Microsemi, Aeroflex, Peregrine, Syfer, Eurofarad, Texas Instrument, Miteq, Cobham, E2V, MA-COM, Hittite, Mini-Circuits, General Dynamics и др.);

Помимо этого, одним из направлений компании «ЭлектроПласт» является направление «Источники питания». Мы предлагаем Вам помощь Конструкторского отдела:

- Подбор оптимального решения, техническое обоснование при выборе компонента;
- Подбор аналогов;
- Консультации по применению компонента;
- Поставка образцов и прототипов;
- Техническая поддержка проекта;
- Защита от снятия компонента с производства.



Как с нами связаться

Телефон: 8 (812) 309 58 32 (многоканальный)

Факс: 8 (812) 320-02-42

Электронная почта: org@eplast1.ru

Адрес: 198099, г. Санкт-Петербург, ул. Калинина, дом 2, корпус 4, литера А.