



DUAL N-CHANNEL AND DUAL P-CHANNEL MATCHED MOSFET PAIR

GENERAL DESCRIPTION

The ALD1105 is a monolithic dual N-channel and dual P-channel complementary matched transistor pair intended for a broad range of analog applications. These enhancement-mode transistors are manufactured with Advanced Linear Devices' enhanced ACMOS silicon gate CMOS process. It consists of an ALD1116 N-channel MOSFET pair and an ALD1117 P-channel MOSFET pair in one package. The ALD1105 is a low drain current, low leakage current version of the ALD1103.

The ALD1105 offers high input impedance and negative current temperature coefficient. The transistor pair is matched for minimum offset voltage and differential thermal response, and it is designed for precision signal switching and amplifying applications in +2V to +12V systems where low input bias current, low input capacitance and fast switching speed are desired. Since these are MOSFET devices, they feature very large (almost infinite) current gain in a low frequency, or near DC, operating environment. When used in complementary pairs, a dual CMOS analog switch can be constructed. In addition, the ALD1105 is intended as a building block for differential amplifier input stages, transmission gates, and multiplexer applications.

The ALD1105 is suitable for use in precision applications which require very high current gain, beta, such as current mirrors and current sources. The high input impedance and the high DC current gain of the Field Effect Transistors result in extremely low current loss through the control gate. The DC current gain is limited by the gate input leakage current, which is specified at 30pA at room temperature. For example, DC beta of the device at a drain current of 3mA at 25°C is $= 3\text{mA}/30\text{pA} = 100,000,000$.

FEATURES

- Thermal tracking between N-channel and P-channel pairs
- Low threshold voltage of 0.7V for both N-channel & P-channel MOSFETS
- Low input capacitance
- Low V_{os} -- 10mV
- High input impedance -- $10^{13}\Omega$ typical
- Low input and output leakage currents
- Negative current (I_{DS}) temperature coefficient
- Enhancement mode (normally off)
- DC current gain 10^9
- Matched N-channel and matched P-channel in one package
- RoHS compliant

ORDERING INFORMATION ("L" suffix denotes lead-free (RoHS))

Operating Temperature Range*		
0°C to +70°C	0°C to +70°C	-55°C to +125°C
14-Pin Small Outline Package (SOIC)	14-Pin Plastic Dip Package	14-Pin CERDIP Package
ALD1105SBL	ALD1105PBL	ALD1105DB

* Contact factory for leaded (non-RoHS) or high temperature versions.

APPLICATIONS

- Precision current mirrors
- Complementary push-pull linear drives
- Analog switches
- Choppers
- Differential amplifier input stage
- Voltage comparator
- Data converters
- Sample and Hold
- Analog inverter
- Precision matched current sources

PIN CONFIGURATION

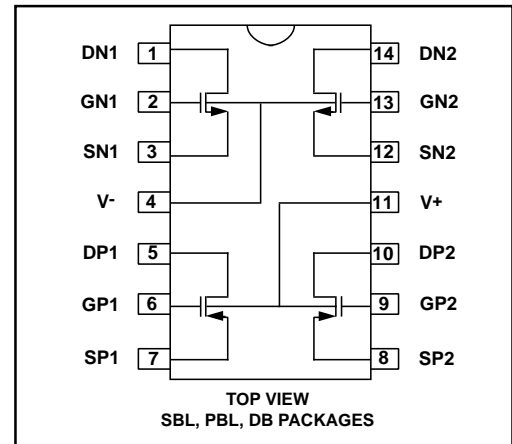

BLOCK DIAGRAM

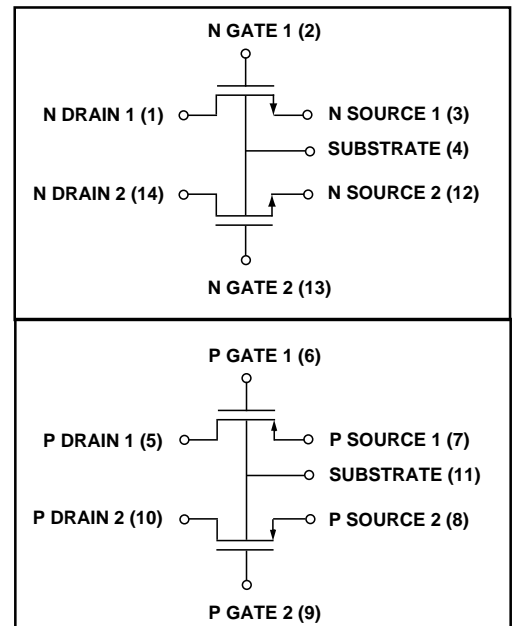

ABSOLUTE MAXIMUM RATINGS

Drain-source voltage, V_{DS} _____ 10.6V
 Gate-source voltage, V_{GS} _____ 10.6V
 Power dissipation _____ 500mW
 Operating temperature range SBL, PBL packages _____ 0°C to +70°C
 DB package _____ -55°C to +125°C
 Storage temperature range _____ -65°C to +150°C
 Lead temperature, 10 seconds _____ +260°C

CAUTION: ESD Sensitive Device. Use static control procedures in ESD controlled environment.

OPERATING ELECTRICAL CHARACTERISTICS

$T_A = 25^\circ\text{C}$ unless otherwise specified

Parameter	Symbol	N - Channel			Unit	Test Conditions	P - Channel			Unit	Test Conditions
		Min	Typ	Max			Min	Typ	Max		
Gate Threshold Voltage	V_T	0.4	0.7	1.0	V	$I_{DS} = 1\mu\text{A}$ $V_{GS} = V_{DS}$	-0.4	-0.7	-1.0	V	$I_{DS} = -1\mu\text{A}$ $V_{GS} = V_{DS}$
Offset Voltage $V_{GS1} - V_{GS2}$	V_{OS}		2	10	mV	$I_{DS} = 10\mu\text{A}$ $V_{GS} = V_{DS}$		2	10	mV	$I_{DS} = -10\mu\text{A}$ $V_{GS} = V_{DS}$
Gate Threshold Temperature Drift	TC_{VT}		-1.2		mV/°C			-1.3		mV/°C	
On Drain Current	$I_{DS(ON)}$	3	4.8		mA	$V_{GS} = V_{DS} = 5\text{V}$	-1.3	-2		mA	$V_{GS} = V_{DS} = -5\text{V}$
Trans-conductance	G_{fs}	1	1.8		mmho	$V_{DS} = 5\text{V}$ $I_{DS} = 10\text{mA}$	0.25	0.67		mmho	$V_{DS} = -5\text{V}$ $I_{DS} = -10\text{mA}$
Mismatch	ΔG_{fs}		0.5		%			0.5		%	
Output Conductance	G_{OS}		200		μmho	$V_{DS} = 5\text{V}$ $I_{DS} = 10\text{mA}$		40		μmho	$V_{DS} = -5\text{V}$ $I_{DS} = -10\text{mA}$
Drain Source ON Resistance	$R_{DS(ON)}$		350	500	Ω	$V_{DS} = 0.1\text{V}$ $V_{GS} = 5\text{V}$		1200	1800	Ω	$V_{DS} = -0.1\text{V}$ $V_{GS} = -5\text{V}$
Drain Source ON Resistance Mismatch	$\Delta R_{DS(ON)}$		0.5		%	$V_{DS} = 0.1\text{V}$ $V_{GS} = 5\text{V}$		0.5		%	$V_{DS} = -0.1\text{V}$ $V_{GS} = -5\text{V}$
Drain Source Breakdown Voltage	BV_{DSS}	12			V	$I_{DS} = 1\mu\text{A}$ $V_{GS} = 0\text{V}$	-12			V	$I_{DS} = -1\mu\text{A}$ $V_{GS} = 0\text{V}$
Off Drain Current	$I_{DS(OFF)}$		10	400	pA nA	$V_{DS} = 12\text{V}$ $I_{GS} = 0\text{V}$ $T_A = 125^\circ\text{C}$		10	400	pA nA	$V_{DS} = -12\text{V}$ $V_{GS} = 0\text{V}$ $T_A = 125^\circ\text{C}$
Gate Leakage Current	I_{GSS}		0.1	30	pA nA	$V_{DS} = 0\text{V}$ $V_{GS} = 12\text{V}$ $T_A = 125^\circ\text{C}$		1	30	pA nA	$V_{DS} = 0\text{V}$ $V_{GS} = -12\text{V}$ $T_A = 125^\circ\text{C}$
Input Capacitance	C_{ISS}		1	3	pF			1	3	pF	

TYPICAL P-CHANNEL PERFORMANCE CHARACTERISTICS

OUTPUT CHARACTERISTICS

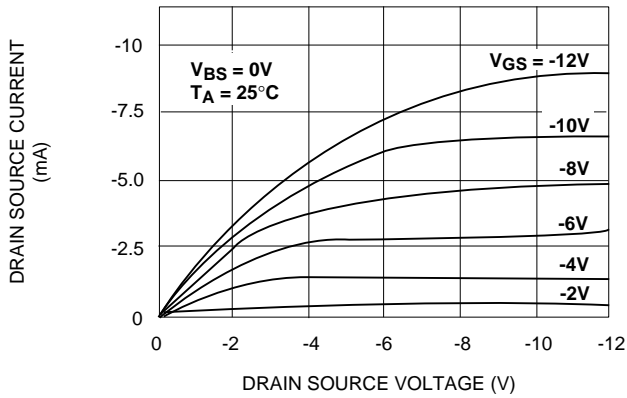

LOW VOLTAGE OUTPUT CHARACTERISTICS

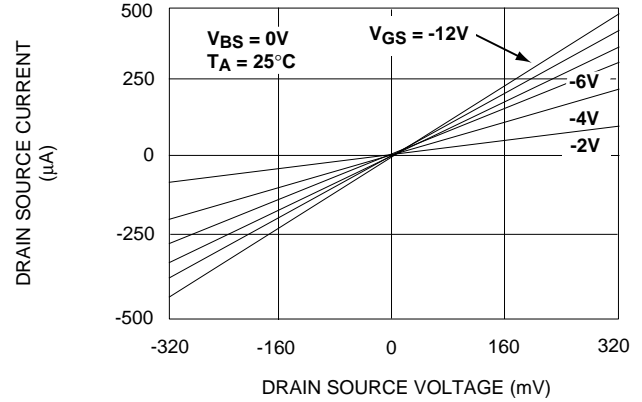

FORWARD TRANSCONDUCTANCE vs. DRAIN SOURCE VOLTAGE

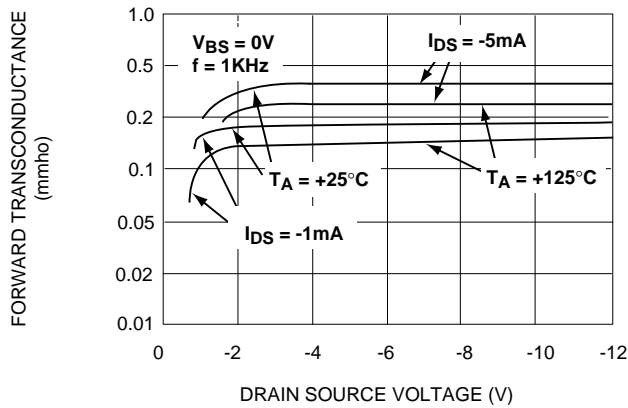

TRANSFER CHARACTERISTIC WITH SUBSTRATE BIAS

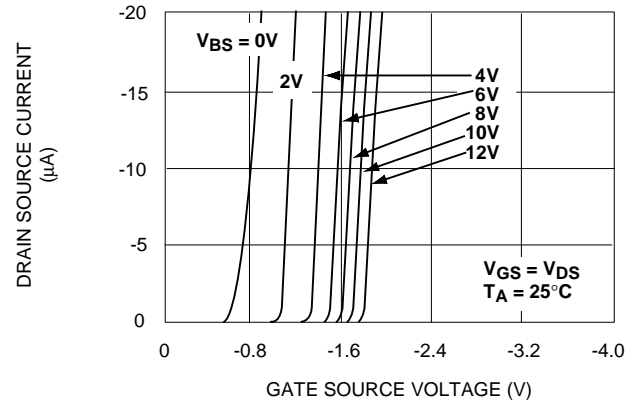

DRAIN SOURCE ON RESISTANCE $R_{DS(ON)}$ vs. GATE SOURCE VOLTAGE

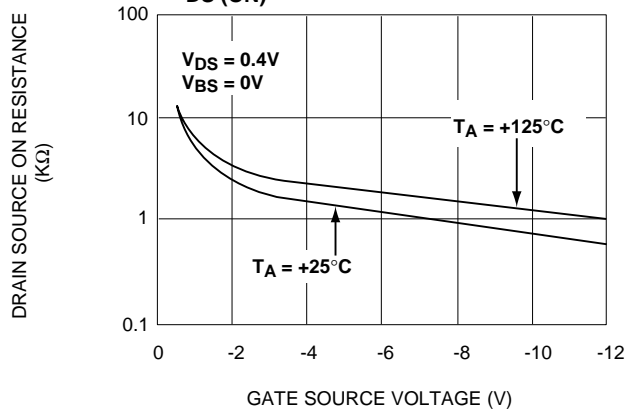

OFF DRAIN CURRENT vs. AMBIENT TEMPERATURE

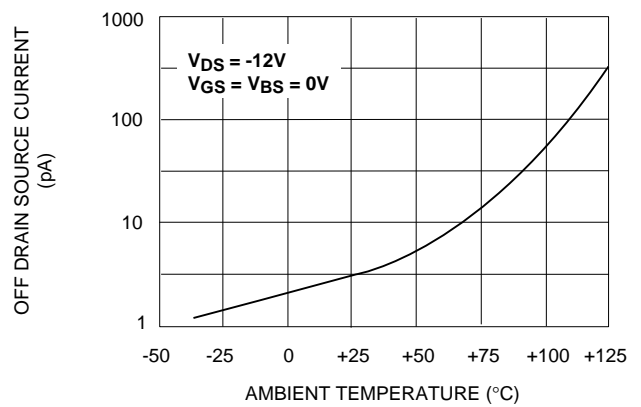

TYPICAL N-CANNEL PERFORMANCE CHARACTERISTICS

OUTPUT CHARACTERISTICS

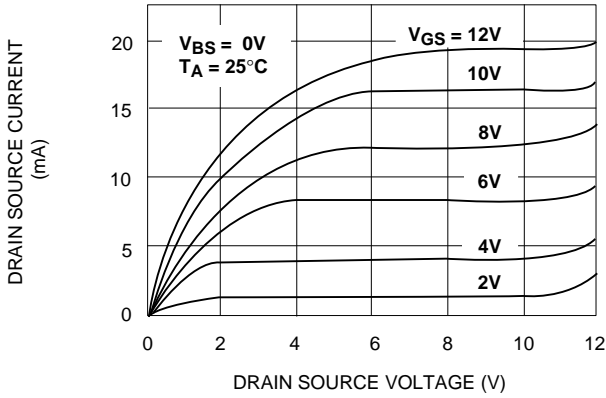

LOW VOLTAGE OUTPUT CHARACTERISTICS

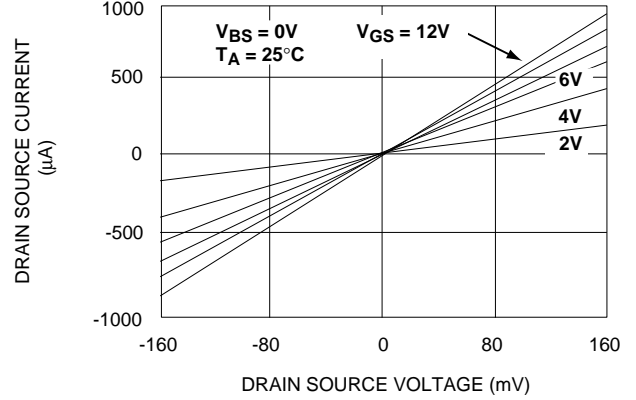

FORWARD TRANSCONDUCTANCE vs. DRAIN SOURCE VOLTAGE

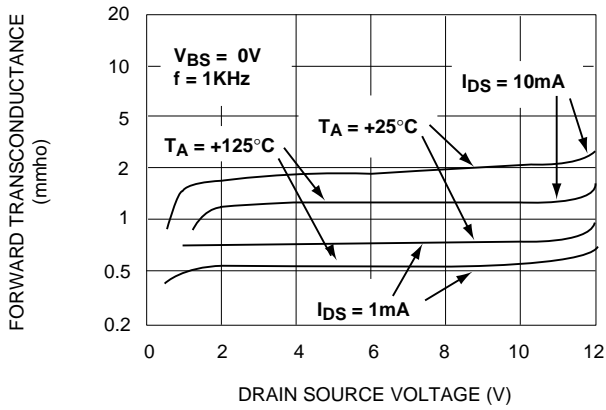

TRANSFER CHARACTERISTIC WITH SUBSTRATE BIAS

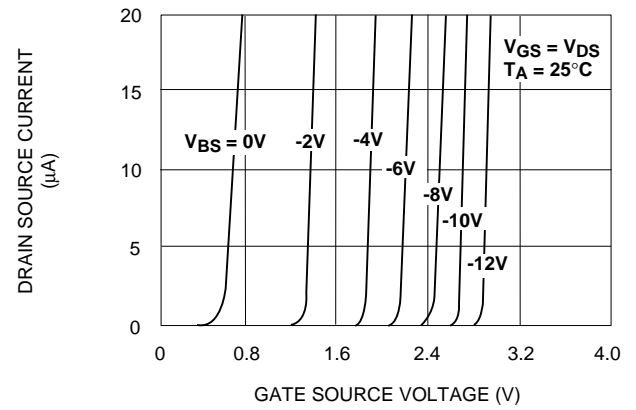

DRAIN SOURCE ON RESISTANCE RDS(ON) vs. GATE SOURCE VOLTAGE

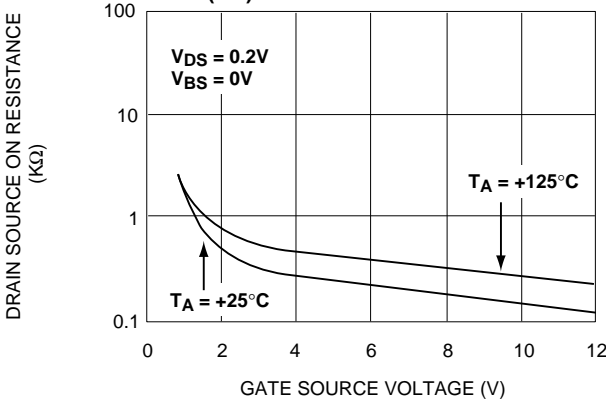

OFF DRAIN CURRENT vs. AMBIENT TEMPERATURE

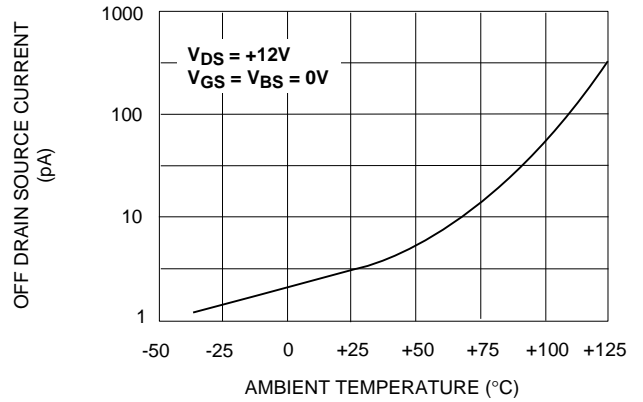

TYPICAL APPLICATIONS

CURRENT SOURCE MIRROR

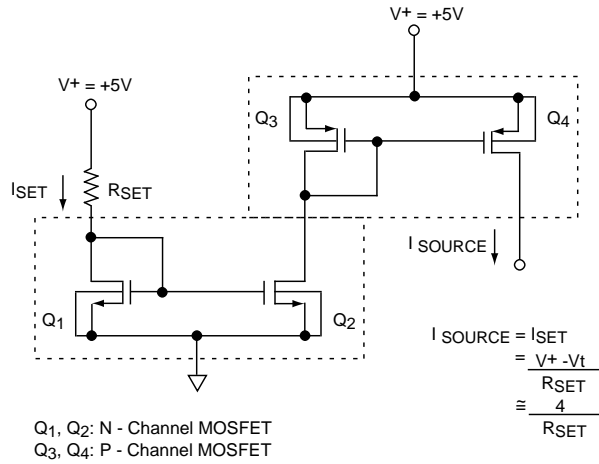

CURRENT SOURCE WITH GATE CONTROL

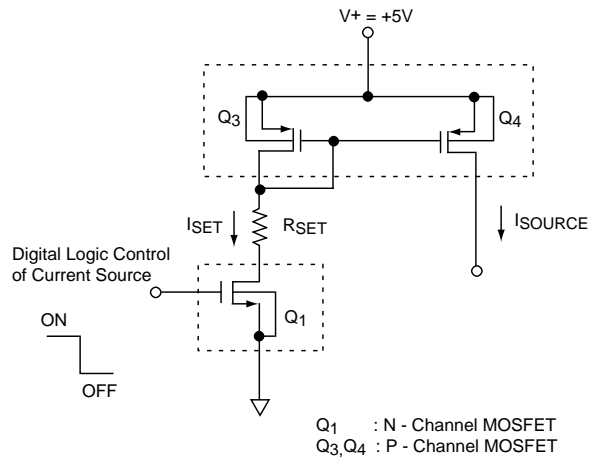

DIFFERENTIAL AMPLIFIER

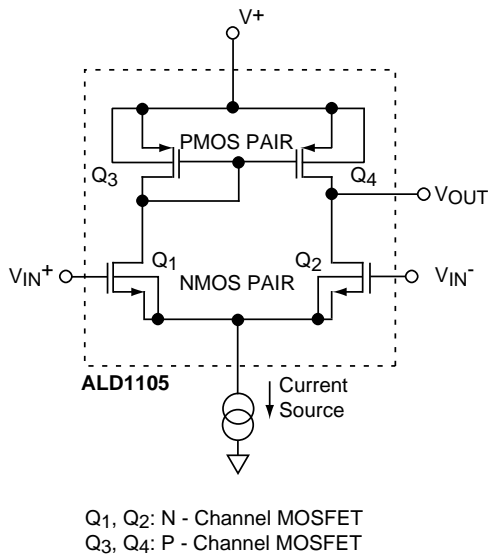

CURRENT SOURCE MULTIPLICATION

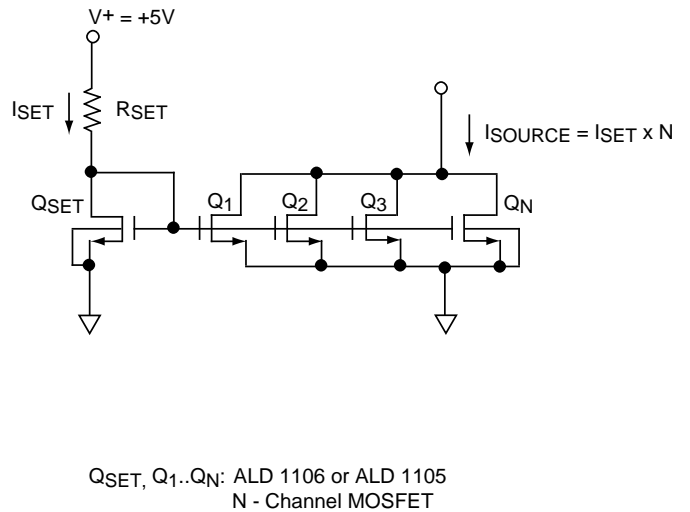

TYPICAL APPLICATIONS (cont.)

BASIC CURRENT SOURCES

N-CHANNEL CURRENT SOURCE

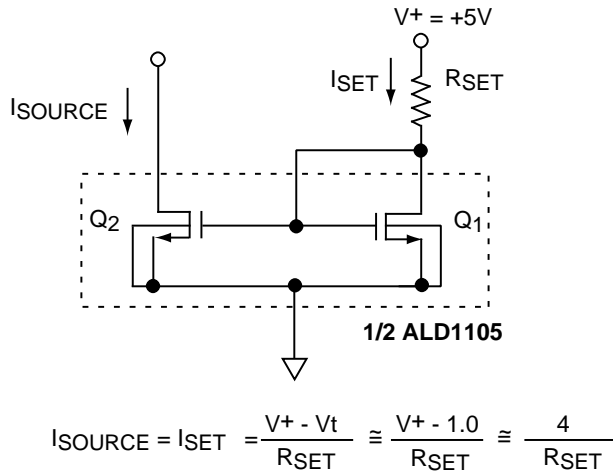

Q1, Q2 : N - Channel MOSFET

P-CHANNEL CURRENT SOURCE

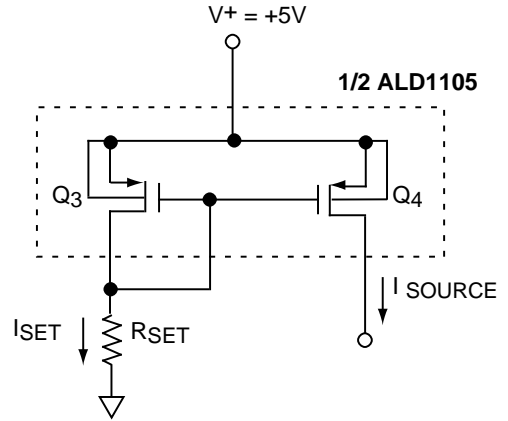

Q3, Q4: P - Channel MOSFET

CASCODE CURRENT SOURCES

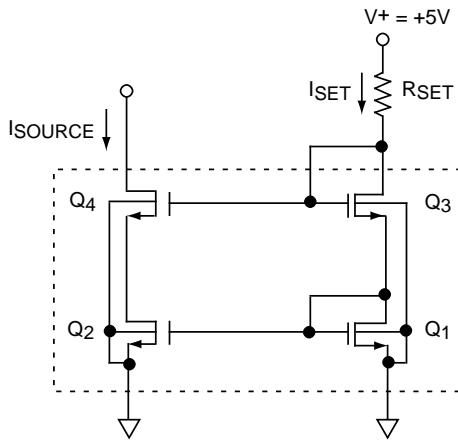

Q1, Q2, Q3, Q4: N - Channel MOSFET
(1/2 ALD1105 + ALD1116)

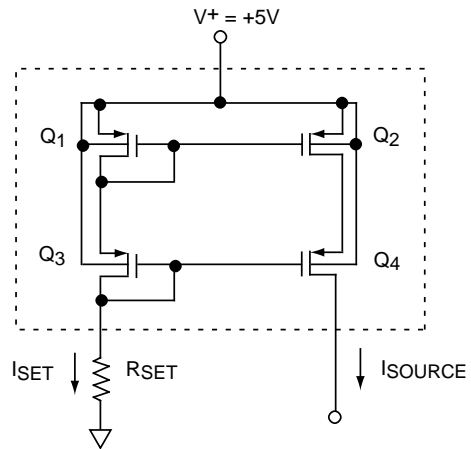

$$I_{SOURCE} = I_{SET} = \frac{V^+ - 2V_t}{R_{SET}} \cong \frac{3}{R_{SET}}$$

Q1, Q2, Q3, Q4: P - Channel MOSFET
(1/2 ALD1105 + ALD1117)

SOIC-14 PACKAGE DRAWING

14 Pin Plastic SOIC Package

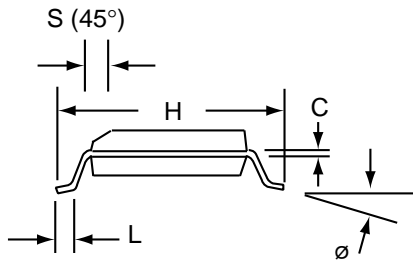
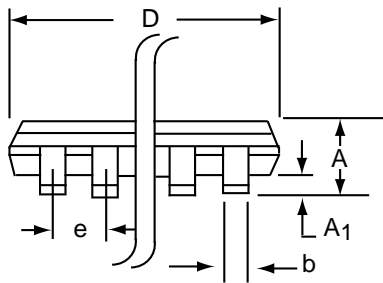
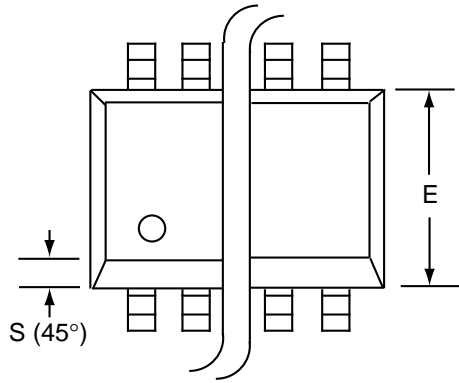

Dim	Millimeters		Inches	
	Min	Max	Min	Max
A	1.35	1.75	0.053	0.069
A ₁	0.10	0.25	0.004	0.010
b	0.35	0.45	0.014	0.018
C	0.18	0.25	0.007	0.010
D-14	8.55	8.75	0.336	0.345
E	3.50	4.05	0.140	0.160
e	1.27 BSC		0.050 BSC	
H	5.70	6.30	0.224	0.248
L	0.60	0.937	0.024	0.037
ø	0°	8°	0°	8°
S	0.25	0.50	0.010	0.020

PDIP-14 PACKAGE DRAWING

14 Pin Plastic DIP Package

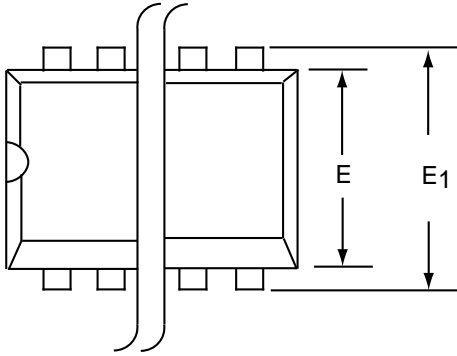

Dim	Millimeters		Inches	
	Min	Max	Min	Max
A	3.81	5.08	0.105	0.200
A ₁	0.38	1.27	0.015	0.050
A ₂	1.27	2.03	0.050	0.080
b	0.89	1.65	0.035	0.065
b ₁	0.38	0.51	0.015	0.020
c	0.20	0.30	0.008	0.012
D-14	17.27	19.30	0.680	0.760
E	5.59	7.11	0.220	0.280
E ₁	7.62	8.26	0.300	0.325
e	2.29	2.79	0.090	0.110
e ₁	7.37	7.87	0.290	0.310
L	2.79	3.81	0.110	0.150
S-14	1.02	2.03	0.040	0.080
∅	0°	15°	0°	15°

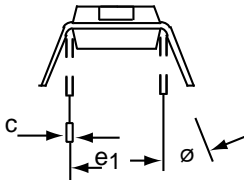
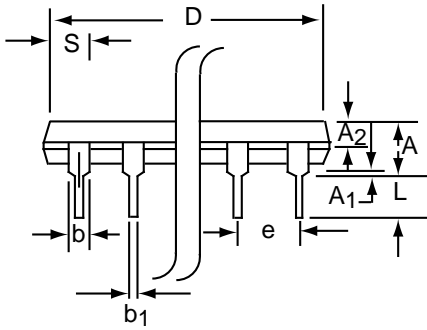

CERDIP-14 PACKAGE DRAWING

14 Pin CERDIP Package

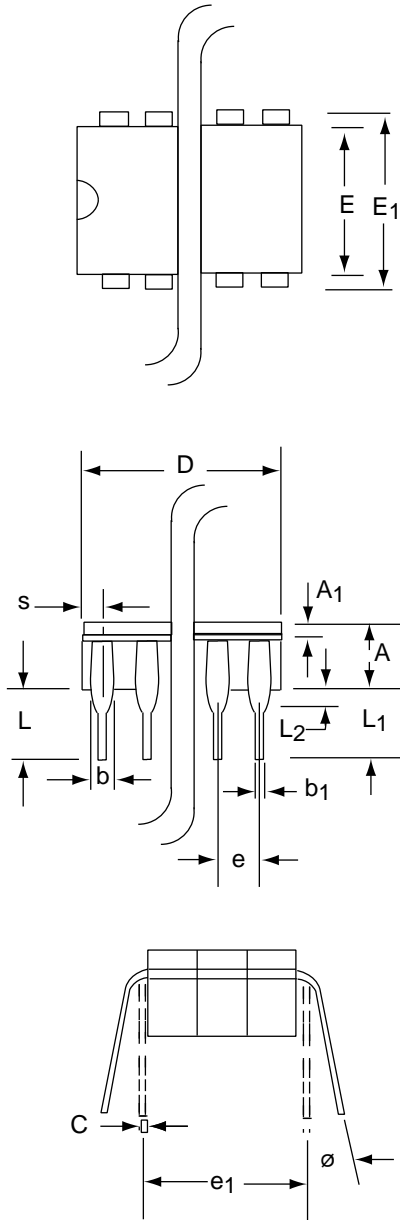

Dim	Millimeters		Inches	
	Min	Max	Min	Max
A	3.55	5.08	0.140	0.200
A₁	1.27	2.16	0.050	0.085
b	0.97	1.65	0.038	0.065
b₁	0.36	0.58	0.014	0.023
C	0.20	0.38	0.008	0.015
D-14	--	19.94	--	0.785
E	5.59	7.87	0.220	0.310
E₁	7.73	8.26	0.290	0.325
e	2.54 BSC		0.100 BSC	
e₁	7.62 BSC		0.300 BSC	
L	3.81	5.08	0.150	0.200
L₁	3.18	--	0.125	--
L₂	0.38	1.78	0.015	0.070
S	--	2.49	--	0.098
Ø	0°	15°	0°	15°



Компания «ЭлектроПласт» предлагает заключение долгосрочных отношений при поставках импортных электронных компонентов на взаимовыгодных условиях!

Наши преимущества:

- Оперативные поставки широкого спектра электронных компонентов отечественного и импортного производства напрямую от производителей и с крупнейших мировых складов;
- Поставка более 17-ти миллионов наименований электронных компонентов;
- Поставка сложных, дефицитных, либо снятых с производства позиций;
- Оперативные сроки поставки под заказ (от 5 рабочих дней);
- Экспресс доставка в любую точку России;
- Техническая поддержка проекта, помощь в подборе аналогов, поставка прототипов;
- Система менеджмента качества сертифицирована по Международному стандарту ISO 9001;
- Лицензия ФСБ на осуществление работ с использованием сведений, составляющих государственную тайну;
- Поставка специализированных компонентов (Xilinx, Altera, Analog Devices, Intersil, Interpoint, Microsemi, Aeroflex, Peregrine, Syfer, Eurofarad, Texas Instrument, Miteq, Cobham, E2V, MA-COM, Hittite, Mini-Circuits, General Dynamics и др.);

Помимо этого, одним из направлений компании «ЭлектроПласт» является направление «Источники питания». Мы предлагаем Вам помощь Конструкторского отдела:

- Подбор оптимального решения, техническое обоснование при выборе компонента;
- Подбор аналогов;
- Консультации по применению компонента;
- Поставка образцов и прототипов;
- Техническая поддержка проекта;
- Защита от снятия компонента с производства.



Как с нами связаться

Телефон: 8 (812) 309 58 32 (многоканальный)

Факс: 8 (812) 320-02-42

Электронная почта: org@eplast1.ru

Адрес: 198099, г. Санкт-Петербург, ул. Калинина, дом 2, корпус 4, литера А.