



IS21ES16G

IS22ES16G

16GB eMMC with eMMC 5.0 Interface
With eMMC 5.0 Interface

DATA SHEET

16GB eMMC with eMMC 5.0 Interface

JUNE 2018

FEATURES

- Packaged NAND flash memory with eMMC 5.0 interface
- IS21/22ES16G: 16Gigabyte
- Compliant with eMMC Specification Ver.4.4, 4.41,4.5,5.0
- Bus mode
 - High-speed eMMC protocol
 - Clock frequency: 0-200MHz.
 - Ten-wire bus (clock, 1 bit command, 8 bit data bus) and a hardware reset.
- Supports three different data bus widths : 1 bit(default), 4 bits, 8 bits
 - Data transfer rate: up to 52Mbyte/s (using 8 parallel data lines at 52 MHz)
 - Single data rate : up to 200Mbyte/s @ 200MHz (HS200)
 - Dual data rate : up to 400Mbyte/s @ 200MHz (HS400)
- Operating voltage range :
 - VCCQ = 1.8 V/3.3 V
 - VCC = 3.3 V
- Supports Enhanced Mode where the device can be configured as pseudo-SLC (pSLC) for higher read/write performance, endurance, and reliability.
- Error free memory access
 - Internal error correction code (ECC) to protect data communication
 - Internal enhanced data management algorithm
 - Solid protection from sudden power failure, safe-update operations for data content
- Security
 - Support secure bad block erase and trim commands
 - Enhanced write protection with permanent and partial protection options
- Field Firmware Update(FFU)
- Boot Partition and RPMB Partition
- Enhanced Device Life time
- Pre EOL information
- Production State Awareness
- Power Off Notification for Sleep
- Temperature range
 - Industrial Grade : -40 °C ~ 85 °C
 - Automotive Grade (A1): -40 °C ~ 85 °C
 - Automotive Grade (A2): -40 °C ~ 105 °C
- Quality
 - RoHS compliant (for detailed RoHS declaration, please contact your representative.)
- Package
 - 153 FBGA (11.5mm x 13mm x 1.0mm)
 - 100 FBGA (14.0mm x 18.0mm x 1.4mm)

GENERAL DESCRIPTION

ISSI *eMMC* products follow the JEDEC *eMMC* 5.0 standard. It is ideal for embedded storage solutions for Industrial application and automotive application, which require high performance across a wide range of operating temperatures.

eMMC encloses the MLC NAND and *eMMC* controller inside as one JEDEC standard package, providing a standard interface to the host. The *eMMC* controller directly manages NAND flash, including ECC, wear-leveling, IOPS optimization and read sensing.

TABLE OF CONTENTS

FEATURES.....	2
GENERAL DESCRIPTION.....	3
TABLE OF CONTENTS.....	4
1. PERFORMANCE SUMMARY.....	6
1.1 SYSTEM PERFORMANCE.....	6
1.2 POWER CONSUMPTION.....	6
1.3 BOOT PARTITION AND RPMB (REPLAY PROTECTED MEMORY BLOCK).....	6
1.4 USER DENSITY.....	6
2. PIN CONFIGURATION.....	7
3. PIN DESCRIPTIONS.....	9
4. eMMC Device and System.....	10
5. REGISTER SETTINGS.....	11
5.1 OCR Register.....	11
5.2 CID Register.....	11
5.3 CSD Register.....	12
5.4 Extended CSD Register.....	14
5.5 RCA Register.....	20
5.6 DSR Register.....	20
6. The eMMC BUS.....	21
7. POWER-UP.....	22
7.1 eMMC POWER-UP.....	22
7.2 eMMC POWER-CYCLING.....	23
8. ELECTRICAL CHARACTERISTICS.....	24
8.1 ABSOLUTE MAXIMUM RATINGS ⁽¹⁾ POWER CONSUMPTION.....	24
8.2 Operating Conditions.....	24
8.2.1 POWER SUPPLY: eMMC.....	25
8.2.2 eMMC Power Supply Voltage.....	25
8.2.3 BUS SIGNAL LINE LOAD.....	26
8.2.4 HS400 REFERENCE LOAD.....	27
8.3 BUS SIGNAL LEVELS.....	28
8.3.1 BUS SIGNAL LINE LOAD.....	28
8.3.2 PUSH-PULL MODE BUS SIGNAL LEVEL-eMMC.....	28
8.3.3 BUS OPERATING CONDITIONS for HS200 & HS400.....	29
8.3.4 BUS DEVICE OUTPUT DRIVER REQUIREMENTS for HS200 & 400.....	29
8.4 BUS TIMING.....	29
8.5 DEVICE INTERFACE TIMING.....	30



8.6 BUS TIMING FOR DAT SIGNALS DURING DUAL DATA RATE OPERATION 32

8.6.1 DUAL DATA RATE INTERFACE TIMINGS..... 32

8.7 BUS TIMING SPECIFICATION IN HS400 MODE..... 33

8.7.1 HS400 DEVICE OUTPUT TIMING 34

9. PACKAGE TYPE INFORMATION 36

10. ORDERING INFORMATION – Valid Part Numbers 38

1. PERFORMANCE SUMMARY

1.1 SYSTEM PERFORMANCE

Product	Typical value			
	Sequential Read (MB/s)	Sequential Write (MB/s)	Random Read (IOPS)	Random Write (IOPS)
IS21/22ES16G	255	24.6	4972	1396

Notes:

1. Values given for an 8-bit bus width, running HS400 mode, $V_{CC}=3.3V$, $V_{CCQ}=1.8V$.
2. Performance numbers might be subject to changes without notice.
3. eMMC Write Reliability ON

1.2 POWER CONSUMPTION

Product	Read (mA)		Write (mA)		Standby (mA)
	$V_{CCQ}(1.8V)$	$V_{CC}(3.3V)$	$V_{CCQ}(1.8V)$	$V_{CC}(3.3V)$	
IS21/22ES16G	205	54	84	51	0.091

Notes:

1. Values given for an 8-bit bus width, a clock frequency of 200MHz DDR mode, $V_{CC}=3.6V\pm 5\%$, $V_{CCQ}=1.95V\pm 5\%$.
2. Standby current is measured at $V_{CC}=3.3V\pm 5\%$, $V_{CCQ}=1.8V\pm 5\%$, 8-bit bus width without clock frequency.
3. Current numbers might be subject to changes without notice.

1.3 BOOT PARTITION AND RPMB (REPLAY PROTECTED MEMORY BLOCK)

Option	Boot partition 1	Boot partition 2	RPMB
J	4,096 KB	4,096 KB	4,096 KB
B	16,384 KB	16,384 KB	4,096 KB

Note:

1. Please see the ordering information for more detail.

1.4 USER DENSITY

Total user density depends on device type.

Product	User Density
IS21/22ES16G	15,636,365,312 Bytes

Note:

1. Current numbers might be subject to changes without notice.

2. PIN CONFIGURATION

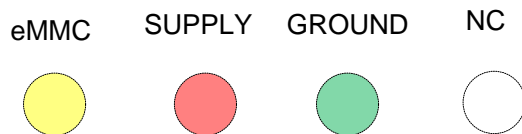
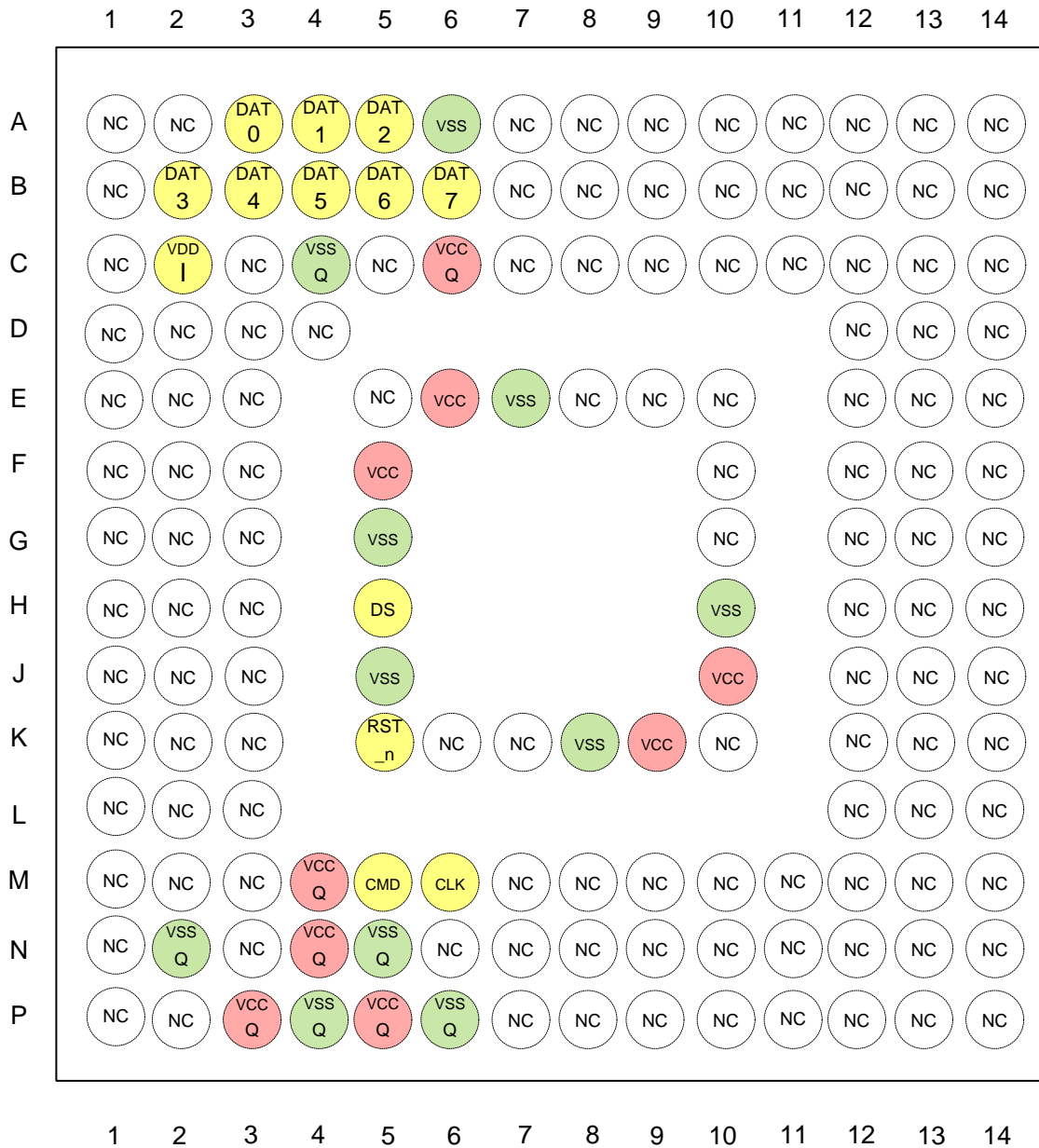
153 FBGA Top View (Ball Down)

Note:

- H5 (DS), A6 (VSS) and J5 (VSS) can be left floating if HS400 mode is not used.

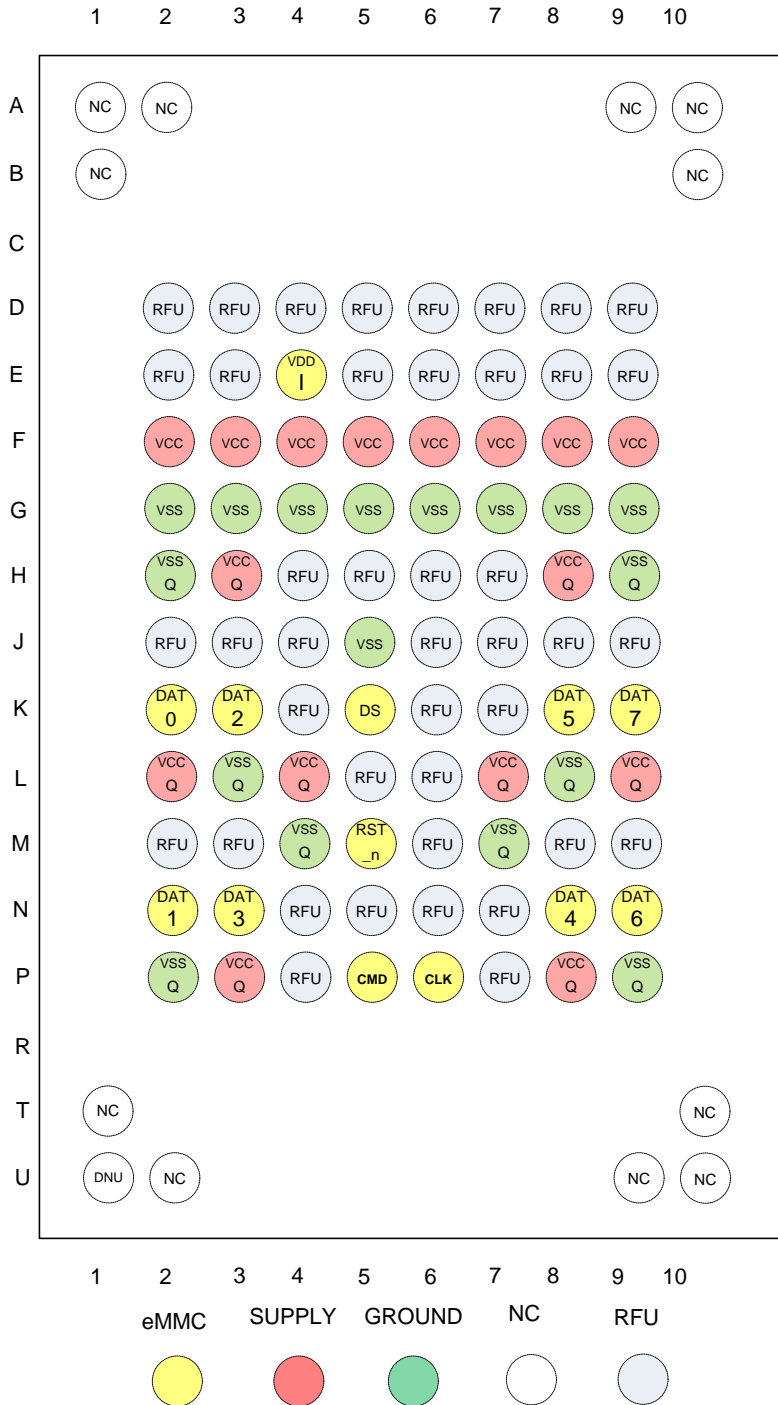
100 FBGA Top View (Ball Down)



Note:

1. K5 (DS) and J5 (VSS) can be left floating if HS400 mode is not used.

3. PIN DESCRIPTIONS

Pin Name	Type ⁽¹⁾	Pin Function
CLK	I	DATA INPUT Each cycle of this signal directs a one bit transfer on the command and either a one bit (1x) or a two bits transfer (2x) on all the data lines. The frequency may vary between zero and the maximum clock frequency
DAT0-DAT7	I/O/PP	DATA These are bidirectional data channels. The DAT signals operate in push-pull mode. Only the Device or the host is driving these signals at a time. By default, after power up or reset, only DAT0 is used for data transfer. A wider data bus can be configured for data transfer, using either DAT0-DAT3 or DAT0-DAT7, by the eMMC host controller. The eMMC Device includes internal pull-ups for data lines DAT1-DAT7. Immediately after entering the 4-bit mode, the Device disconnects the internal pull ups of lines DAT1, DAT2, and DAT3. Correspondingly, immediately after entering to the 8-bit mode the Device disconnects the internal pull-ups of lines DAT1-DAT7.
CMD	I/O/PP/OD	COMMAND/RESPONSE This signal is a bidirectional command channel used for Device initialization and transfer of commands. The CMD signal has two operation modes: open-drain for initialization mode, and push-pull for fast command transfer. Commands are sent from the eMMC host controller to the eMMC Device and responses are sent from the Device to the host.
RST#	I	HARDWARE RESET
DS	O/PP	Data Strobe This signal is generated by the device and used for output in HS400 mode. The frequency of this signal follows the frequency of CLK. For data output each cycle of this signal directs two bits transfer(2x) on the data - one bit for positive edge and the other bit for negative edge. For CRC status response output and CMD response output (enabled only HS400 enhanced strobe mode), the CRC status is latched on the positive edge only, and don't care on the negative edge.
VDDI		INTERNAL VOLTAGE NODE At least a 0.1uF capacitor is required to connect VDDI to ground. A 1uF capacitor is recommended. Do not tie to supply voltage or ground.
VCC	-	POWER SUPPLY VCC is the power supply for Core
VCCQ	-	POWER SUPPLY VCC is the power supply for I/O
VSS	-	Ground VSS is the ground for Core
VSSQ	-	GROUND VSSQ is the ground for I/O
RFU		Reserved For Future Use
N.C.		NO CONNECTION Lead is not internally connected.

Note:

1. I: input; O: output; PP: push-pull; OD: open-drain; NC: Not connected (or logical high); S: power

4. eMMC Device and System

eMMC consists of a single chip MMC controller and NAND flash memory module. The micro-controller interfaces with a host system allowing data to be written to and read from the NAND flash memory module. The controller allows the host to be independent from details of erasing and programming the flash memory.

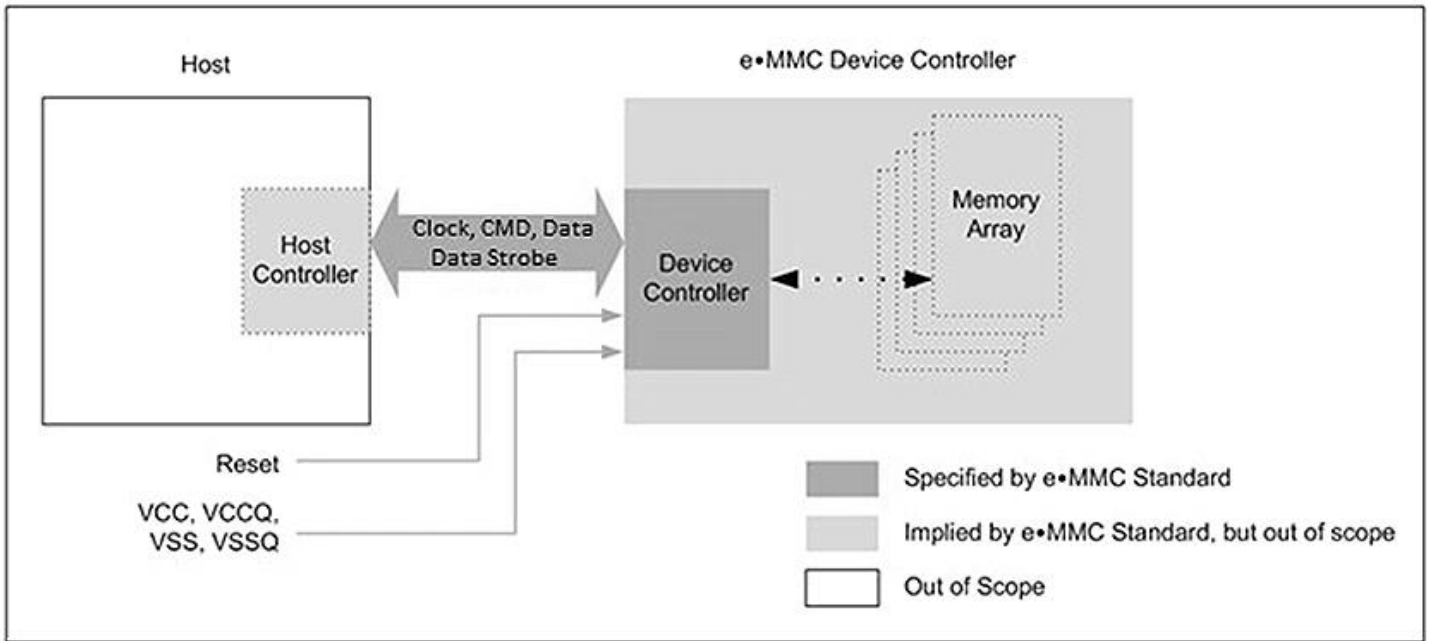

Figure 4.1 eMMC System Overview

5. REGISTER SETTINGS

5.1 OCR Register

The 32-bit operation conditions register (OCR) stores the VDD voltage profile of the Device and the access mode indication. In addition, this register includes a status information bit. This status bit is set if the Device power up procedure has been finished. The OCR register shall be implemented by all Devices.

Table 5.1 OCR Register

VCCQ Voltage Window	Width (Bits)	OCR Bit	OCR Value
Device power up status bit (busy) ⁽¹⁾	1	[31]	Note 1
Access Mode	2	[30:29]	10b(sector mode)
Reserved	5	[28:24]	0 0000b
VCCQ: 2.7 – 3.6V	9	[23:15]	1 1111 1111b
VCCQ: 2.0 – 2.6V	7	[14:8]	000 0000b
VCCQ: 1.7 – 1.95V	1	[7]	1b
Reserved	7	[6:0]	000 0000b

Note:

1. This bit is set to LOW if the device has not finished the power up routine.

5.2 CID Register

The Card Identification (CID) register is 128 bits wide. It contains the Device identification information used during the Device identification phase (*eMMC* protocol).

Table 5.2 CID Register

Name	Field	Width (Bits)	CID Bits	CID Value
Manufacturer ID	MID	8	[127:120]	9Dh
Reserved	-	6	[119:114]	-
Device/BGA	CBX	2	[113:112]	1h
OEM/application ID	OID	8	[111:104]	1h
Product Name	PNM	48	[103:56]	IS016G
Product Revision	PRV	8	[55:48]	50h
Product Serial Number	PSN	32	[47:16]	Random by Production
Manufacturing Date	MDT	8	[15:8]	Month, Year
CRC7 Checksum	CRC	7	[7:1]	- ⁽¹⁾
Not used, always "1"	-	1	[0]	1h

Note:

1. The description is same as *eMMC*™ JEDEC standard.

5.3 CSD Register

The Card-Specific Data (CSD) register provides information on how to access the contents stored in eMMC. The CSD registers are used to define the error correction type, maximum data access time, data transfer speed, data format...etc. For details, refer to section 7.3 of the JEDEC Standard Specification No.JESD84-B50.

Table 5.3 CSD Register

Name	Field	Width (Bits)	CSD Bits	CSD Value ⁽¹⁾
CSD Structure	CSD_STRUCTURE	2	[127:126]	3h
System Specification Version	SPEC_VERS	4	[125:122]	4h
Reserved ⁽²⁾	-	2	[121:120]	-
Data Read Access Time 1	TAAC	8	[119:112]	4Fh
Data Read Access Time 2 in CLK Cycles (NSAC x 100)	NSAC	8	[111:104]	1h
Maximum Bus Clock Frequency	TRAN_SPEED	8	[103:96]	32h
Card Command Classes	CCC	12	[95:84]	F5h
Maximum Read Data Block Length	READ_BL_LEN	4	[83:80]	9h
Partial Blocks for Reads supported	READ_BL_PARTIAL	1	[79]	0h
Write Block Misalignment	WRITE_BLK_MISALIGN	1	[78]	0h
Read Block Misalignment	READ_BLK_MISALIGN	1	[77]	0h
DS Register Implemented	DSR_IMP	1	[76]	0h
Reserved ⁽²⁾	-	2	[75:74]	-
Device Size	C-SIZE	12	[73:62]	FFFh
Maximum Read Current at VDD min	VDD_R_CURR_MIN	3	[61:59]	7h
Maximum Read Current at VDD max	VDD_R_CURR_MAX	3	[58:56]	7h
Maximum Write Current at VDD min	VDD_W_CURR_MIN	3	[55:53]	7h
Maximum Write Current at VDD max	VDD_W_CURR_MAX	3	[52:50]	7h
Device Size Multiplier	C_SIZE_MULT	3	[49:47]	7h
Erase Group Size	ERASE_GRP_SIZE	5	[42:46]	1Fh
Erase Group Size Multiplier	ERASE_GRP_SIZE_MULT	5	[41:37]	1Fh
Write Protect Group Size	WR_GRP_SIZE	5	[36:32]	0Fh
Write Protect Group Enable	WR_GRP_ENABLE	1	[31]	1h
Manufacturer Default ECC	DEFAULT_ECC	2	[30:29]	0h
Write-Speed Factor	R2W_FACTOR	3	[28:26]	2h

Name	Field	Width (Bits)	CSD Bits	CSD Value ⁽¹⁾
Maximum Write Data Block Length	WRITE_BL_LEN	4	[25:22]	9h
Partial Blocks for Writes supported	WRITE_BL_PARTIAL	1	[21]	0h
Reserved ⁽²⁾	-	4	[20:17]	-
Content Protection Application	CONTENT_PROT_APP	1	[16]	0h
File-Format Group	FILE_FORMAT_GRP	1	[15]	0h
Copy Flag (OTP)	COPY	1	[14]	0h
Permanent Write Protection	PERM_WRITE_PROTECT	1	[13]	0h
Temporary Write Protection	TEMP_WRITE_PROTECT	1	[12]	0h
File Format	FILE_FORMAT	2	[11:10]	0h
ECC	ECC	2	[9:8]	0h
CRC	CRC	7	[7:1]	30h
Not Used, always "1"	-	1	[0]	1h

Note:

1. CSD value might be subject to change without notice.

5.4 Extended CSD Register

The Extended CSD register defines the Device properties and selected modes. It is 512 bytes long. The most significant 320 bytes are the Properties segment, which defines the Device capabilities and cannot be modified by the host. The lower 192 bytes are the Modes segment, which defines the configuration the Device is working in. These modes can be changed by the host by means of the SWITCH command. For details, refer to section 7.4 of the JEDEC Standard Specification No.JESD84-B50.

Table 5.4 ECSD Register

Name	Field	Size (Bytes)	ECSD Bits	ECSD Value
Reserved	-	6	[511:506]	-
Extended Security Commands Error	EXT_SECURITY_ERR	1	[505]	0h
Supported Command Sets	S_CMD_SET	1	[504]	1h
HPI Features	HPI_FEATURES	1	[503]	1h
Background Operations Support	BKOPS_SUPPORT	1	[502]	1h
Max Packed Read Commands	MAX_PACKED_READS	1	[501]	3Ch
Max Packed Write Commands	MAX_PACKED_WRITES	1	[500]	3Ch
Data Tag Support	DATA_TAG_SUPPORT	1	[499]	1h
Tag Unit Size	TAG_UNIT_SIZE	1	[498]	3h
Tag Resources Size	TAG_RES_SIZE	1	[497]	0h
Context Management Capabilities	CONTEXT_CAPABILITIES	1	[496]	5h
Large Unit Size	LARGE_UNIT_SIZE_M1	1	[495]	07h
Extended Partitions Attribute Support	EXT_SUPPORT	1	[494]	3h
Supported Modes	SUPPORT_MODES	1	[493]	1h
FFU Features	FFU_FEATURES	1	[492]	0h
Operations Code Timeout	OPERATION_CODE_TIEMOUT	1	[491]	0h
FFU Argument	FFU_ARG	4	[490:487]	65535
Reserved	-	181	[486:306]	-
Number of FW Sectors Correctly Programmed	NUMBER_OF_FW_SECTORS_CORRECTLY_PROGRAMMED	4	[305:302]	0h
Vendor Proprietary Health Report	VENDOR_PROPRIETARY_HEALTH_REPORT	32	[301:270]	0h
Device Life Time Estimation Type B	DEVICE_LIFE_TIME_EST_TYP_B	1	[269]	1h
Device Life Time Estimation Type A	DEVICE_LIFE_TIME_EST_TYP_A	1	[268]	1h
Pre EOL Information	PRE_EOL_INFO	1	[267]	1h

Name	Field	Size (Bytes)	ECSD Bits	ECSD Value ⁽¹⁾
Optimal Read Size	OPTIMAL_READ_SIZE	1	[266]	1h
Optimal Write Size	OPTIMAL_WRITE_SIZE	1	[265]	8h
Optimal Trim Unit Size	OPTIMAL_TRIM_UNIT_SIZE	1	[264]	1h
Device Version	DEVICE_VERSION	2	[263:262]	0h
Firmware Version	FIRMWARE_VERSION	8	[261:254]	-
Power Class for 200MHz, DDR at VCC=3.6V	PWR_CL_DDR_200_360	1	[253]	0h
Cache Size	CACHE_SIZE	4	[252:249]	1024
Generic CMD6 Timeout	GENERIC_CMD6_TIME	1	[248]	19h
Power Off Notification (Long) Timeout	POWER_OFF_LONG_TIME	1	[247]	FFh
Background Operations Status	BKOPS_STATUS	1	[246]	0h
Number of Correctly Programmed Sectors	CORRECTLY_PRG_SECTORS_NUM	4	[245:242]	0h
First Initialization Time After Partitioning (First CMD1 to Device ready)	INI_TIMEOUT_PA	1	[241]	64h
Reserved	-	1	[240]	-
Power Class for 52MHz, DDR at 3.6V	PWR_CL_DDR_52_360	1	[239]	0h
Power Class for 52MHz, DDR at 1.95V	PWR_CL_DDR_52_195	1	[238]	0h
Power Class for 200MHz at 3.6V	PWR_CL_200_360	1	[237]	0h
Power Class for 200MHz at 1.95V	PWR_CL_200_195		[236]	0h
Minimum Write Performance for 8-bit at 52MHz in DDR Mode	MIN_PERF_DDR_W_8_52	1	[235]	0h
Minimum Read Performance for 8-bit at 52MHz in DDR Mode	MIN_PERF_DDR_R_8_52	1	[234]	0h
Reserved	-	1	[233]	-
TRIM Multiplier	TRIM_MULT	1	[232]	11h
Secure Feature Support	SEC_FEATURE_SUPPORT	1	[231]	55h
SECURE ERASE Multiplier	SEC_ERASE_MULT	1	[230]	25h
SECURE TRIM Multiplier	SEC_TRIM_MULT	1	[229]	25h
Boot Information	BOOT_INFO	1	[228]	7h
Reserved	-	1	[227]	-
Boot Partition Size	BOOT_SIZE_MULT	J-Option	[226]	20h
		B-Option		80h

Name	Field	Size (Bytes)	ECSD Bits	ECSD Value ⁽¹⁾
Access Size	ACC_SIZE	1	[225]	7h
High-Capacity Erase Unit Size	HC_ERASE_GRP_SIZE	1	[224]	1h
High-Capacity Erase Timeout	ERASE_TIMEOUT_MULT	1	[223]	11h
Reliable Write-Sector Count	REL_WR_SEC_C	1	[222]	1h
High-Capacity Write Protect Group Size	HC_WP_GRP_SIZE	1	[221]	10h
Sleep Current (V _{CC})	S_C_VCC	1	[220]	0Ah
Sleep Current (V _{CCQ})	S_C_VCCQ	1	[219]	0Bh
Production State Awareness Timeout	PRODUCTION_STATE_AWARENESS_TIMEOUT	1	[218]	14h
Sleep/Awake Timeout	S_A_TIMEOUT	1	[217]	13h
Sleep Notification Timeout	SLEEP_NOTIFICATION_TIME	1	[216]	0Fh
Sector Count	SEC_COUNT	4	[215:212]	30539776 ⁽⁵⁾
Reserved	-	1	[211]	-
Minimum Write Performance for 8-bit at 52MHz	MIN_PERF_W_8_52	1	[210]	8h
Minimum Read Performance for 8-bit at 52MHz	MIN_PERF_R_8_52	1	[209]	8h
Minimum Write Performance for 8-bit at 26MHz and 4-bit at 52MHz	MIN_PERF_W_8_26_4_52	1	[208]	8h
Minimum Read Performance for 8-bit at 26MHz and 4-bit at 52MHz	MIN_PERF_R_8_26_4_52	1	[207]	8h
Minimum Write Performance for 4-bit at 26MHz	MIN_PERF_W_4_26	1	[206]	8h
Minimum Read Performance for 4-bit at 26MHz	MIN_PERF_R_4_26	1	[205]	8h
Reserved	-	1	[204]	-
Power Class for 26MHz at 3.6V	PWR_CL_26_360	1	[203]	0h
Power Class for 52MHz at 3.6V	PWR_CL_52_360	1	[202]	0h
Power Class for 26MHz at 1.95V	PWR_CL_26_195	1	[201]	0h
Power Class for 52MHz at 1.95V	PWR_CL_52_195	1	[200]	0h
Partition Switching Timing	PARTITION_SWITCH_TIME	1	[199]	3h
Out-of-Interrupt Busy Timing	OUT_OF_INTERRUPT_TIME	1	[198]	4h

Name	Field	Size (Bytes)	ECSD Bits	ECSD Value ⁽¹⁾
I/O Driver Strength	DRIVER_STRENGTH	1	[197]	1Fh
Card Type	CARD_TYPE	1	[196]	57h
Reserved	-	1	[195]	-
CSD Structure Version	CSD_STRUCTURE	1	[194]	2h
Reserved	-	1	[193]	-
Extended CSD Structure Revision	EXT_CSD_REV	1	[192]	7h
Command Set	CMD_SET	1	[191]	0h
Reserved	-	1	[190]	-
Command Set Revision	CMD_SET_REV	1	[189]	0h
Reserved	-	1	[188]	-
Power Class	POWER_CLASS	1	[187]	0h
Reserved	-	1	[186]	-
High-Speed Interface Timing	HS_TIMING	1	[185]	1h ⁽³⁾
Reserved	-	1	[184]	-
Bus Width Mode	BUS_WIDTH	1	[183]	2h ⁽⁴⁾
Reserved	-	1	[182]	-
Erased memory Content	ERASED_MEM_CONT	1	[181]	0h
Reserved	-	1	[180]	-
Partition Configuration	PARTITION_CONFIG	1	[179]	0h
Boot Configuration Protection	BOOT_CONFIG_PROT	1	[178]	0h
Boot Bus Width	BOOT_BUS_CONDITIONS	1	[177]	0h
Reserved	-	1	[176]	-
High-Density Erase Group Definition	ERASE_GROUP_DEF	1	[175]	0h
Boot Write Protection Status Registers	BOOT_WP_STATUS	1	[174]	0h
Boot Area Write Protection Register	BOOT_WP	1	[173]	0h
Reserved	-	1	[172]	-
User Write Protection Register	USER_WP	1	[171]	0h
Reserved	-	1	[170]	-
Firmware Configuration	FW_CONFIG	1	[169]	0h
RPMB Size	RPMB_SIZE_MULT	1	[168]	20h
Write Reliability Setting Register	WR_REL_SET	1	[167]	1Fh
Write Reliability Parameter Register	WR_REL_PARAM	1	[166]	04h
Start Sanitize Operation	SANITIZE_START	1	[165]	0h
Manually Start Background Operations	BKOPS_START	1	[164]	0h

Name	Field	Size (Bytes)	ECSD Bits	ECSD Value ⁽¹⁾
Enable Background Operations Handshake	BKOPS_EN	1	[163]	0h
Hardware Reset Function	RST_n_FUNCTION	1	[162]	0h
HPI Management	HPI_MGMT	1	[161]	0h
Partitioning Support	PARTITIONING_SUPPORT	1	[160]	7h
Maximum Enhanced Area Size	MAX_ENH_SIZE_MULT	3	[159:157]	932
Partitions Attribute	PATTITIONS_ATTRIBUTE	1	[156]	0h
Partitioning Setting	PARTITIONING_SETTING_COMPLETED	1	[155]	0h
General-Purpose Partition Size	GP_SIZE_MULT4	12	[154:152]	0h
	GP_SIZE_MULT3		[151:149]	0h
	GP_SIZE_MULT2		[148:146]	0h
	GP_SIZE_MULT1		[145:143]	0h
Enhanced User Data Area Size	ENH_SIZE_MULT	3	[142:140]	0h
Enhanced User Data Start Address	ENH_START_ADDR	4	[139:136]	0h
Reserved	-	1	[135]	-
Bad Block Management mode	SEC_BAD_BLK_MGMNT	1	[134]	0h
Production State Awareness	PRODUCTION_STATE_AWARENESS	1	[133]	0h
Package Case Temperature is controlled	TCASE_SUPPORT	1	[132]	0h
Periodic Wake-Up	PERIODIC_WAKEUP	1	[131]	0h
Program CID/CSD in DDR Mode Support	PROGRAM_CID_CSD_DDR_SUPPORT	1	[130]	1h
Reserved	-	2	[129:128]	-
Vendor Specific Fields	VENDOR_SPECIFIC_NFIELD	64	[127:64]	-
Native Sector Size	NATIVE_SECTOR_SIZE	1	[63]	0h
Sector Size Emulation	USE_NATIVE_SECTOR	1	[62]	0h
Sector Size	DATA_SECTOR_SIZE	1	[61]	0h
1 st Initialization After Disabling Sector Size Emulation	INI_TIMEOUT_EMU	1	[60]	0h
Class 6 Command Control	CLASS_6_CTRL	1	[59]	0h
Number of Addressed Groups To Be Released	DYNCAP_NEEDED	1	[58]	0h
Exception Events Control	EXCEPTION_EVENTS_CTRL	2	[57:56]	0h
Exception Events Status	EXCEPTION_EVENTS_STATUS	2	[55:54]	0h
Extended Partitions Attribute	EXT_PARTITIONS_ATTRIBUTE	2	[53:52]	0h

Name	Field	Size (Bytes)	ECSD Bits	ECSD Value ⁽¹⁾
Context Configuration	CONTEXT_CONF	15	[51:37]	0h
Packed Command Status	PACKED_COMMAND_STATUS	1	[36]	0h
Packed Command Failure Index	PACKED_FAILURE_INDEX	1	[35]	0h
Power Off Notification	POWER_OFF_NOTIFICATION	1	[34]	0h
Control To Turn The Cache ON/OFF	CACHE_CTRL	1	[33]	0h
Flushing Of The Cache	FLUSH_CACHE	1	[32]	0h
Reserved	-	1	[31]	-
Mode Config	MODE_CONFIG	1	[30]	0h
Mode Operation Codes	MODE_OPERATION_STATUS	1	[29]	0h
Reserved	-	2	[28:27]	-
FFU Status	FFU_STATUS	1	[26]	0h
Pre Loading Data Size	PRE_LOADING_DATA_SIZE	4	[25:22]	0h
Max Pre Loading Data Size	MAX_PRE_LOADING_DATA_SIZE	4	[21:18]	15204352 ⁽⁵⁾
Product State Awareness Enablement	PRODUCT_STATE_AWARENESS_ENABLEMENT	1	[17]	1h
Secure Removal Type	SECURE_REMOVAL_TYPE	1	[16]	1h
Command Queue Mod Enable	CMQ_MODE_EN	1	[15]	0h
Reserved	-	15	[14:0]	

Note:

1. Reserved bits should read as "0".
2. Obsolete values should be don't care.
3. This field is 0 after power-on, H/W reset or software reset, thus selecting the backwards compatible interface timing for the Device. If the host sets 1 to this field, the Device changes the timing to high speed interface timing (see Section 10.6.1 of JESD84-B50). If the host sets value 2, the Device changes its timing to HS200 interface timing (see Section 10.8.1 of JESD854-B50). If the host sets HS_TIMING [3:0] to 0x3, the device changes it's timing to HS400 interface timing (see 10.10).
4. It is set to "0" (1bit data bus) after power up and can be changed by a SWITCH command.
5. Could be changed by Firmware update.

5.5 RCA Register

The writable 16-bit Relative Device Address (RCA) register carries the Device address assigned by the host during the Device identification. This address is used for the addressed host-Device communication after the Device identification procedure. The default value of the RCA register is 0x0001. The value 0x0000 is reserved to set all Devices into the *Stand-by State* with CMD7. For detailed register setting value, please refer to FAE.

5.6 DSR Register

The 16-bit driver stage register (DSR) is described in detail in Section 7.6 of the JEDEC Standard Specification No.JESD84-B50. It can be optionally used to improve the bus performance for extended operating conditions (depending on parameters like bus length, transfer rate or number of Devices). The CSD register carries the information about the DSR register usage. For detailed register setting value, please refer to FAE.

Table 5.1 eMMC Registers

Name	Width (Bytes)	Description	Implementation
CID	16	Device Identification number, an individual number for identification.	Mandatory
RCA	2	Relative Device Address is the Device system address, dynamically assigned by the host during initialization.	Mandatory
DSR	2	Driver Stage Register, to configure the Device's output drivers.	Optional
CSD	16	Device Specific Data, information about the Device operation conditions.	Mandatory
OCR	4	Operation Conditions Register. Used by a special broadcast command to identify the voltage type of the Device.	Mandatory
EXT_CSD	512	Extended Device Specific Data. Contains information about the Device capabilities and selected modes. Introduced in standard v4.0	Mandatory

6. The eMMC BUS

The eMMC bus has ten communication lines and three supply lines:

- CMD : Command is a bidirectional signal. The host and Device drivers are operating in two modes, open drain and push/pull.
- DAT0-7 : Data lines are bidirectional signals. Host and Device drivers are operating in push-pull mode
- CLK : Clock is a host to Device signal. CLK operates in push-pull mode
- Data Strobe: Data Strobe is a Device to host signal. Data Strobe operates in push-pull mode.

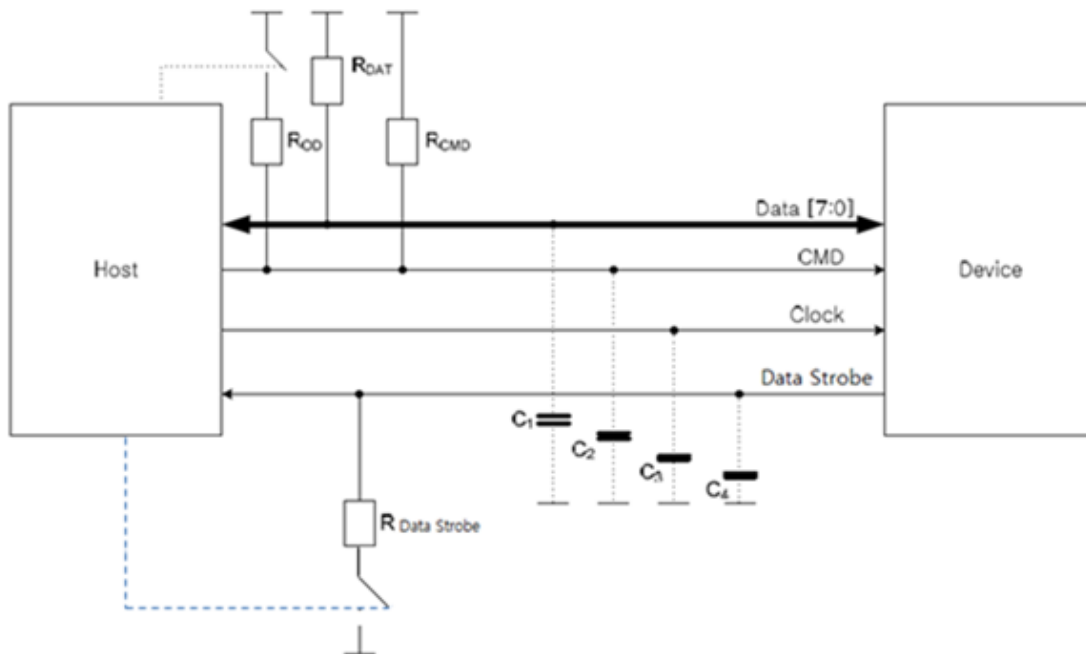

Figure 6.1 BUS Circuitry Diagram

The R_{OD} is switched on and off by the host synchronously to the open-drain and push-pull mode transitions. The host does not have to have open drain drivers, but must recognize this mode to switch on the R_{OD} . R_{DAT} and R_{CMD} are pull-up resistors protecting the CMD and the DAT lines against bus floating device when all device drivers are in a high-impedance mode.

A constant current source can replace the R_{OD} by achieving a better performance (constant slopes for the signal rising and falling edges). If the host does not allow the switchable R_{OD} implementation, a fixed R_{CMD} can be used). Consequently the maximum operating frequency in the open drain mode has to be reduced if the used R_{CMD} value is higher than the minimal one given in.

$R_{Data\ strobe}$ is pull-down resistor used in HS400 device.

7. POWER-UP

7.1 eMMC POWER-UP

An eMMC bus power-up is handled locally in each device and in the bus master. 7.1 shows the power-up sequence and is followed by specific instructions regarding the power-up sequence. Refer to section 12.1 of the JEDEC Standard Specification No. JESD84-B50 for specific instructions regarding the power-up sequence.

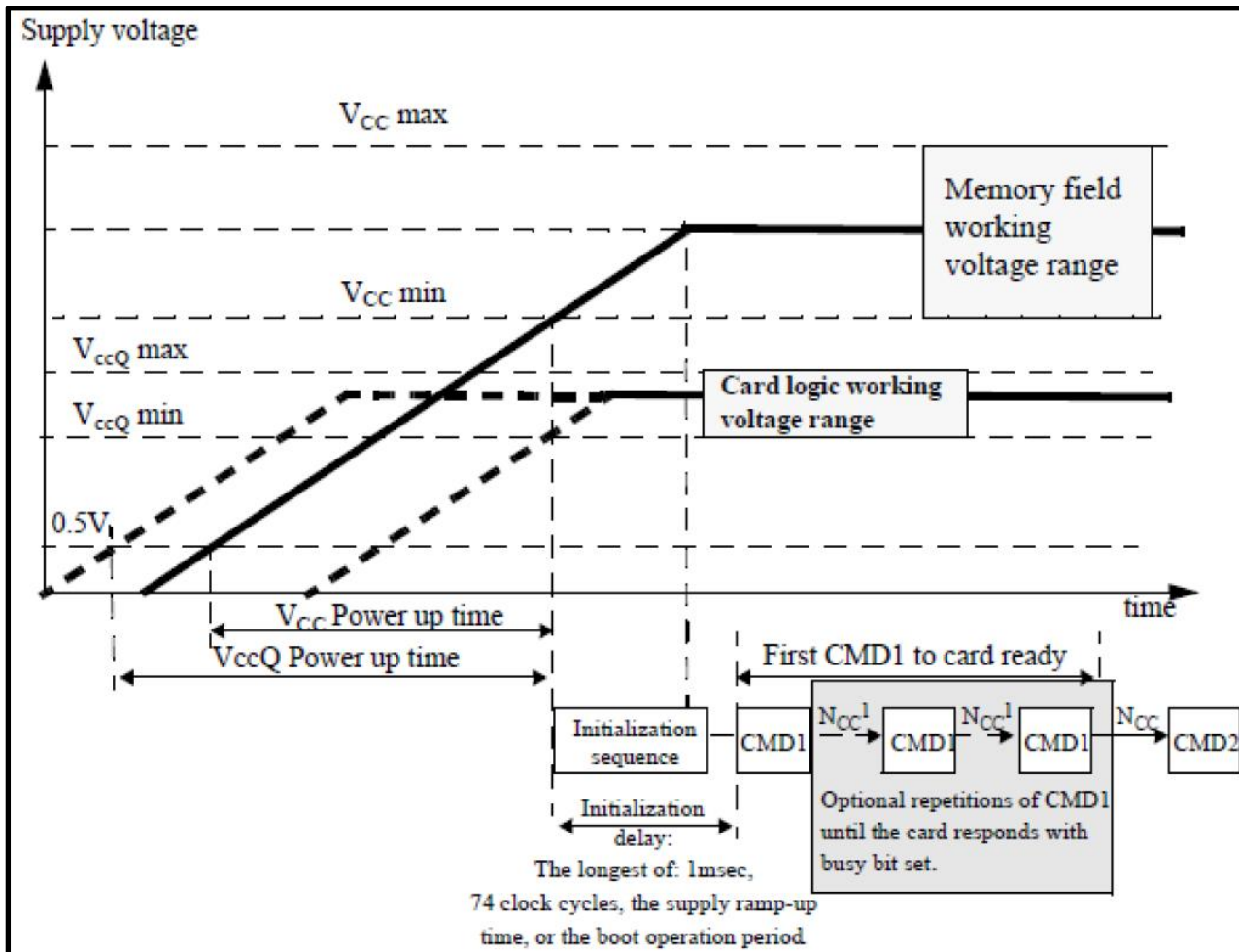

Figure 7.1 eMMC POWER-UP Diagram

7.2 eMMC POWER-CYCLING

The master can execute any sequence of V_{CC} and V_{CCQ} power-up/power-down. However, the master must not issue any commands until V_{CC} and V_{CCQ} are stable within each operating voltage range. After the slave enters sleep mode, the master can power-down V_{CC} to reduce power consumption. It is necessary for the slave to be ramped up to V_{CC} before the host issues CMD5 (SLEEP_AWAKE) to wake the slave unit. For more information about power cycling see Section 10.1.3 of the JEDEC Standard Specification No. JESD84-B50.

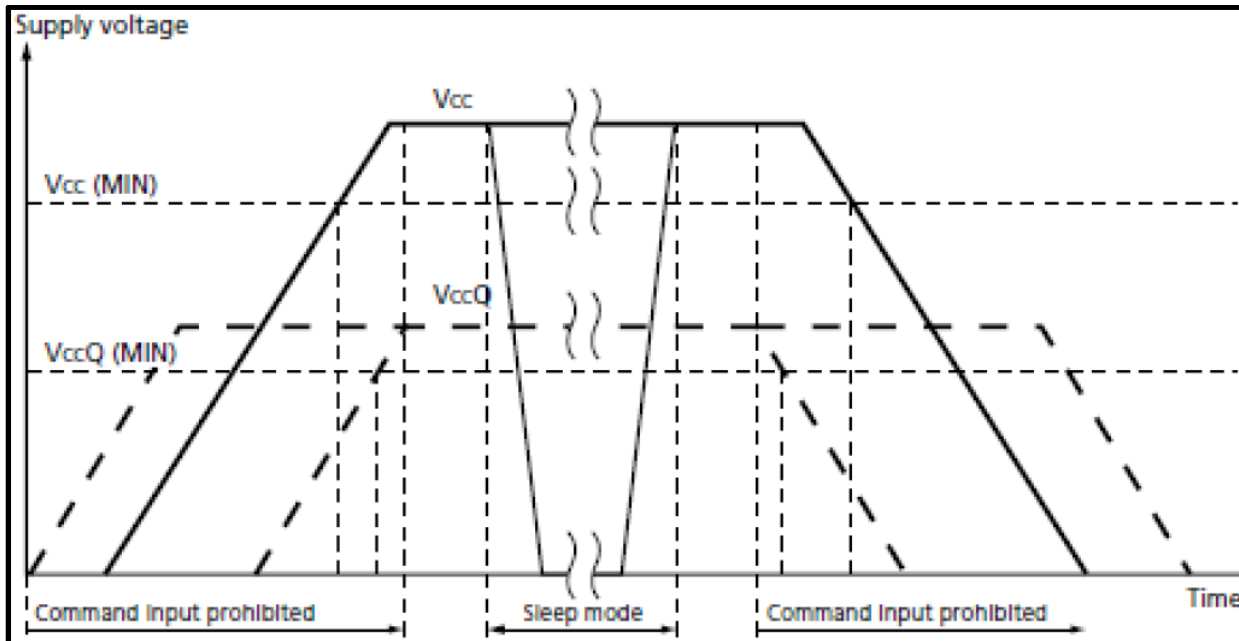

Figure 7.2 eMMC POWER-CYCLE

8. ELECTRICAL CHARACTERISTICS

8.1 ABSOLUTE MAXIMUM RATINGS ⁽¹⁾ POWER CONSUMPTION

Input Voltage	-0.6V to +4.6V
V _{CC} Supply	-0.6V to +4.6V
V _{CCQ} Supply	-0.6V to +4.6V

Notes:

1. Applied conditions greater than those listed in “Absolute Maximum Ratings” may cause permanent damage to the device. This is a stress rating only and functional operation of the device at these or any other conditions above those indicated in the operational sections of this specification is not implied. Exposure to absolute maximum rating conditions for extended periods may affect reliability.

8.2 Operating Conditions

Parameter	Symbol	Min	Max.	Unit	Remark
Peak voltage on all lines		-0.5	V _{CCQ} + 0.5	V	
All Inputs					
Input Leakage Current (before initialization sequence and/or the internal pull up resistors connected)		-100	100	μA	
Input Leakage Current (after initialization sequence and the internal pull up resistors disconnected)		-2	2	μA	
All Outputs					
Output Leakage Current (before initialization sequence)		-100	100	μA	
Output Leakage Current (after initialization sequence)		-2	2	μA	

Notes:

1. Initialization sequence is defined in Section 10.1 of the JEDEC Standard Specification No. JESD84-B50.
2. DS (Data Strobe) pin is excluded.

8.2.1 POWER SUPPLY: eMMC

In the eMMC, VCC is used for the NAND flash device and its interface voltage; VCCQ is for the controller and the MMC interface voltage as shown in Figure 8.1. The core regulator is optional and only required when internal core logic voltage is regulated from VCCQ. A CReg capacitor must be connected to the VDDi terminal to stabilize regulator output on the system.

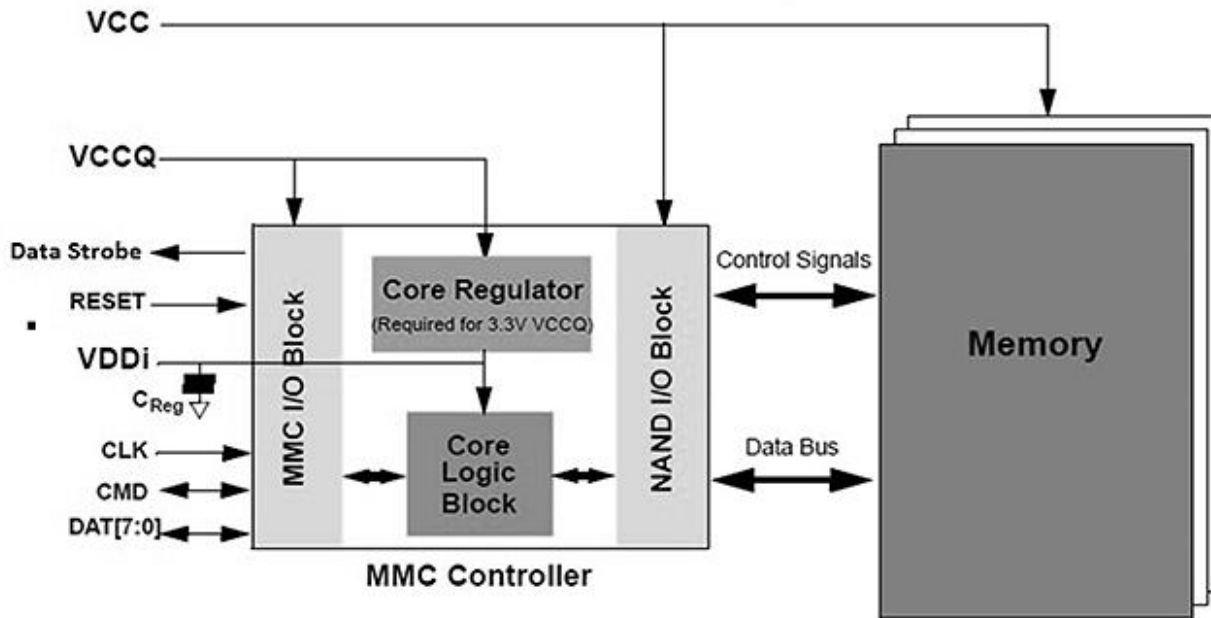

Figure 8.1 eMMC Internal Power Diagram

8.2.2 eMMC Power Supply Voltage

The eMMC supports one or more combinations of VCC and VCCQ as shown in Table 8.1. The VCCQ must be defined at equal to or less than VCC.

Table 8.1 – eMMC Operating Voltage

Parameter	Symbol	MIN	MAX	Unit	Remarks
Supply voltage (NAND)	VCC	2.7	3.6	V	
Supply voltage (I/O)	VCCQ	2.7	3.6	V	
		1.7	1.95	V	
Supply power-up for 3.3V	t _{PRUH}		35	ms	
Supply power-up for 1.8V	t _{PRUL}		25	ms	

The eMMC must support at least one of the valid voltage configurations, and can optionally support all valid voltage configurations.

Table 8.2 – eMMC Voltage Combinations

		VCCQ	
		1.7V–1.95V	2.7V–3.6V ¹
VCC	2.7V–3.6V	Valid	Valid

Note:

- VCCQ (I/O) 3.3 volt range is not supported in HS200 /HS400 devices.

8.2.3 BUS SIGNAL LINE LOAD

The total capacitance C_L of each line of the eMMC bus is the sum of the bus master capacitance C_{HOST} , the bus capacitance C_{BUS} itself and the capacitance C_{DEVICE} of eMMC connected to this line:

$$C_L = C_{HOST} + C_{BUS} + C_{DEVICE}$$

The sum of the host and bus capacitances must be under 20pF.

Table 8.3 – Signal Line Load

Parameter	Symbol	Min	Max	Unit	Remark
Pull-up resistance for CMD	R_{CMD}	4.7	50	Kohm	to prevent bus floating
Pull-up resistance for DAT0–7	R_{DAT}	10	50	Kohm	to prevent bus floating
Bus signal line capacitance	C_L		30	pF	Single Device
Single Device capacitance	C_{DEVICE}		6	pF	
Maximum signal line inductance			16	nH	
V_{CCQ} decoupling capacitor		2.2+0.1	4.7+0.22	μF	It should be located as close as possible to the balls defined in order to minimize connection parasitic
VCC capacitor value		1+0.1	4.7+0.22	μF	It should be located as close as possible to the balls defined in order to minimize connection parasitic
V_{DDI} capacitor value	C_{REG}	1	4.7+0.1	μF	To stabilize regulator output to controller core logics. It should be located as close as possible to the balls defined in order to minimize connection parasitic

8.2.4 HS400 REFERENCE LOAD

The circuit in Figure 8.2 shows the reference load used to define the HS400 Device Output Timings and overshoot / undershoot parameters.

The reference load is made up by the transmission line and the $C_{\text{REFERENCE}}$ capacitance.

The reference load is not intended to be a precise representation of the typical system environment nor a depiction of the actual load presented by a production tester.

System designers should use IBIS or other simulation tools to correlate the reference load to system environment.

Manufacturers should correlate to their production test conditions.

Delay time (t_d) of the transmission line has been introduced to make the reference load independent from the PCB technology and trace length.

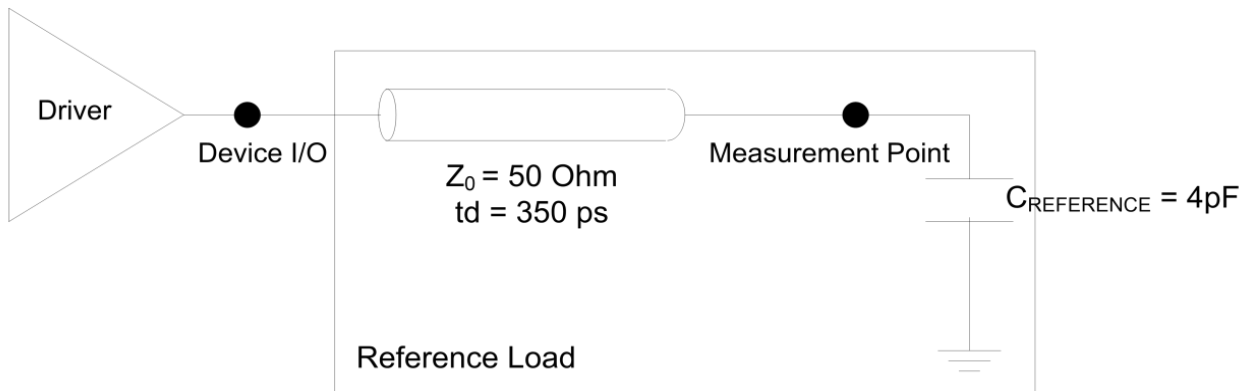

Figure 8.2 HS400 Reference Load

8.3 BUS SIGNAL LEVELS

As the bus can be supplied with a variable supply voltage, all signal levels are related to the supply voltage.

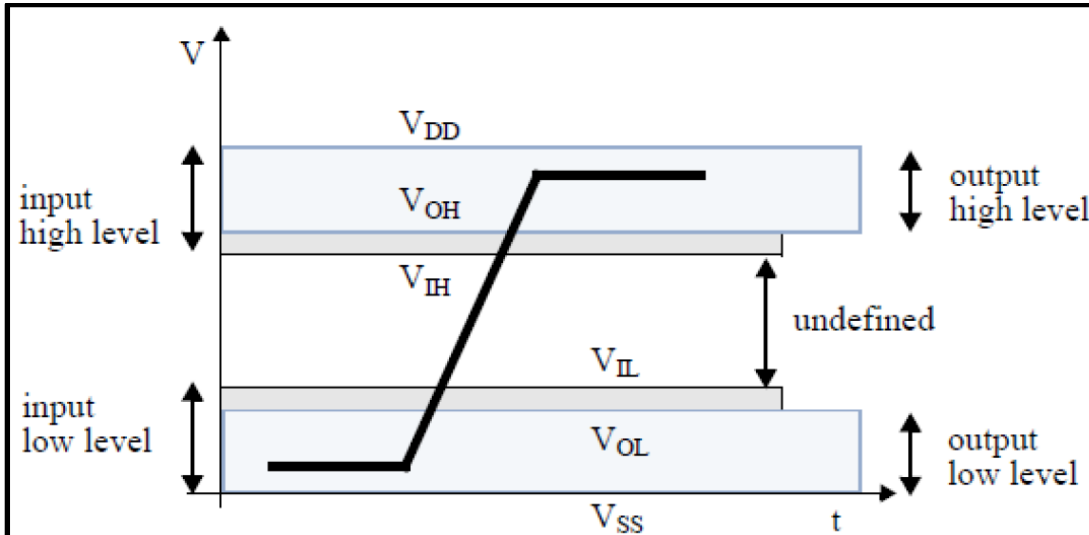

Figure 8.3 BUS Signal Levels

8.3.1 BUS SIGNAL LINE LOAD

The total capacitance C_L of each line of the eMMC bus is the sum of the bus master capacitance C_{HOST} , the bus capacitance C_{BUS} itself and the capacitance C_{DEVICE} of eMMC connected to this line:

$$C_L = C_{HOST} + C_{BUS} + C_{DEVICE}$$

The sum of the host and bus capacitances must be under 20pF.

Table 8.4 – Open-drain Bus Signal Level

Parameter	Symbol	Min	Max.	Unit	Conditions
Output HIGH voltage	VOH	VDD – 0.2		V	IOH = -100 μ A
Output LOW voltage	VOL		0.3	V	IOL = 2 mA

The input levels are identical with the push-pull mode bus signal levels.

8.3.2 PUSH-PULL MODE BUS SIGNAL LEVEL-eMMC

The device input and output voltages shall be within the following specified ranges for any V_{DD} of the allowed voltage range

For 2.7V-3.6V V_{CCQ} range (compatible with JESD8C.01)

Table 8.5 – Push-pull Signal Level—High-voltage eMMC

Parameter	Symbol	Min	Max.	Unit	Conditions
Output HIGH voltage	VOH	0.75 * VCCQ		V	IOH = -100 μ A @ VCCQ min
Output LOW voltage	VOL		0.125 * VCCQ	V	IOL = 100 μ A @ VCCQ min
Input HIGH voltage	VIH	0.625 * VCCQ	VCCQ + 0.3	V	
Input LOW voltage	VIL	VSS – 0.3	0.25 * VCCQ	V	

For 1.70V – 1.95V V_{CCQ} range (: Compatible with EIA/JEDEC Standard “EIA/JESD8-7 Normal Range” as defined in the following table.

Table 8.6 – Push-pull Signal Level—1.70 -1.95 V_{CCQ} Voltage Range

Parameter	Symbol	Min	Max.	Unit	Conditions
Output HIGH voltage	VOH	$V_{CCQ} - 0.45V$		V	IOH = -2mA
Output LOW voltage	VOL		0.45V	V	IOL = 2mA
Input HIGH voltage	VIH	$0.65 * V_{CCQ}^1$	$V_{CCQ} + 0.3$	V	
Input LOW voltage	VIL	$V_{SS} - 0.3$	$0.35 * V_{DD}^2$	V	

Notes:

1. $0.7 * V_{DD}$ for MMC™4.3 and older revisions /HS400 devices.
2. $0.3 * V_{DD}$ for MMC™4.3 and older revisions.

8.3.3 BUS OPERATING CONDITIONS for HS200 & HS400

The bus operating conditions for HS200 devices is the same as specified in sections 10.5.1 of JESD84-B50 through 13.5.2 of JESD84-B50. The only exception is that $V_{CCQ}=3.3v$ is not supported.

8.3.4 BUS DEVICE OUTPUT DRIVER REQUIREMENTS for HS200 & 400

Refer to section 10.5.4 of the JEDEC Standard Specification No.JESD84-B50.

8.4 BUS TIMING

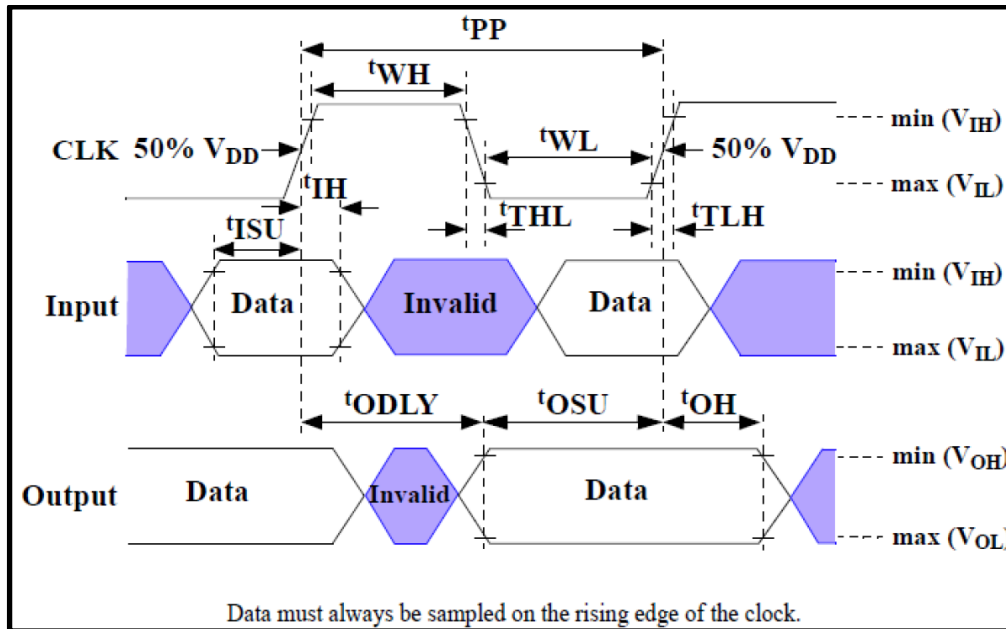

Figure 8.4 BUS Timing Diagram

8.5 DEVICE INTERFACE TIMING

Table 8.7 – High-speed Device Interface Timing

Parameter	Symbol	Min	Max.	Unit	Remark
Clock CLK ¹					
Clock frequency Data Transfer Mode (PP) ²	fPP	0	52 ³	MHz	CL ≤ 30 pF Tolerance: +100KHz
Clock frequency Identification Mode (OD)	fOD	0	400	kHz	Tolerance: +20KHz
Clock high time	tWH	6.5		ns	CL ≤ 30 pF
Clock low time	tWL	6.5		ns	CL ≤ 30 pF
Clock rise time ⁴	tTLH		3	ns	CL ≤ 30 pF
Clock fall time	tTHL		3	ns	CL ≤ 30 pF
Inputs CMD, DAT (referenced to CLK)					
Input set-up time	tISU	3		ns	CL ≤ 30 pF
Input hold time	tIH	3		ns	CL ≤ 30 pF
Outputs CMD, DAT (referenced to CLK)					
Output delay time during data transfer	tODLY		13.7	ns	CL ≤ 30 pF
Output hold time	tOH	2.5		ns	CL ≤ 30 pF
Signal rise time ⁵	tRISE		3	ns	CL ≤ 30 pF
Signal fall time	tFALL		3	ns	CL ≤ 30 pF

Notes:

1. CLK timing is measured at 50% of VDD devices.
2. eMMC shall support the full frequency range from 0-26Mhz or 0-52MH.
3. Device can operate as high-speed Device interface timing at 26 MHz clock frequency.
4. CLK rise and fall times are measured by min (VIH) and max (VIL).
5. Inputs CMD DAT rise and fall times are measured by min (VIH) and max (VIL) and outputs CMD DAT rise and fall times are measured by min (VOH) and max (VOL).

Table 8.8 – Backward-compatible Device Interface Timing

Clock CLK ²					
Clock frequency Data Transfer Mode (PP) ³	fPP	0	26	MHz	CL ≤ 30 pF
Clock frequency Identification Mode (OD)	fOD	0	400	kHz	
Clock high time	tWH	10			CL ≤ 30 pF
Clock low time	tWL	10		ns	CL ≤ 30 pF
Clock rise time ⁴	tTLH		10	ns	CL ≤ 30 pF
Clock fall time	tTHL		10	ns	CL ≤ 30 pF
Inputs CMD, DAT (referenced to CLK)					
Input set-up time	tISU	3		ns	CL ≤ 30 pF
Input hold time	tIH	3		ns	CL ≤ 30 pF
Outputs CMD, DAT (referenced to CLK)					
Output set-up time ⁵	tOSU	11.7		ns	CL ≤ 30 pF
Output hold time ⁵	tOH	8.3		ns	CL ≤ 30 pF

Notes:

1. The Device must always start with the backward-compatible interface timing. The timing mode can be switched to high-speed interface timing by the host sending the SWITCH command (CMD6) with the argument for high-speed interface select.
2. CLK timing is measured at 50% of VDD.
3. For compatibility with Devices that support the v4.2 standard or earlier, host should not use > 26 MHz before switching to high-speed interface timing.
4. CLK rise and fall times are measured by min (VIH) and max (VIL).
5. tOSU and tOH are defined as values from clock rising edge. However, there may be Devices or devices which utilize clock falling edge to output data in backward compatibility mode. Therefore, it is recommended for hosts either to settWL value as long as possible within the range which will not go over tCK-tOH(min) in the system or to use slow clock frequency, so that host could have data set up margin for those devices. In this case, each device which utilizes clock falling edge might show the correlation either between tWL and tOSU or between tCK and tOSU for the device in its own datasheet as a note or its application notes.

8.6 BUS TIMING FOR DAT SIGNALS DURING DUAL DATA RATE OPERATION

These timings apply to the DAT [7:0] signals only when the device is configured for dual data mode operation. In this dual data mode, the DAT signals operate synchronously of both the rising and the falling edges of CLK. The CMD signal still operates synchronously of the rising edge of CLK and therefore complies with the bus timing specified in section 10.5 of JEDEC Standard Specification No. JESD84-B50, therefore there is no timing change for the CMD signal.

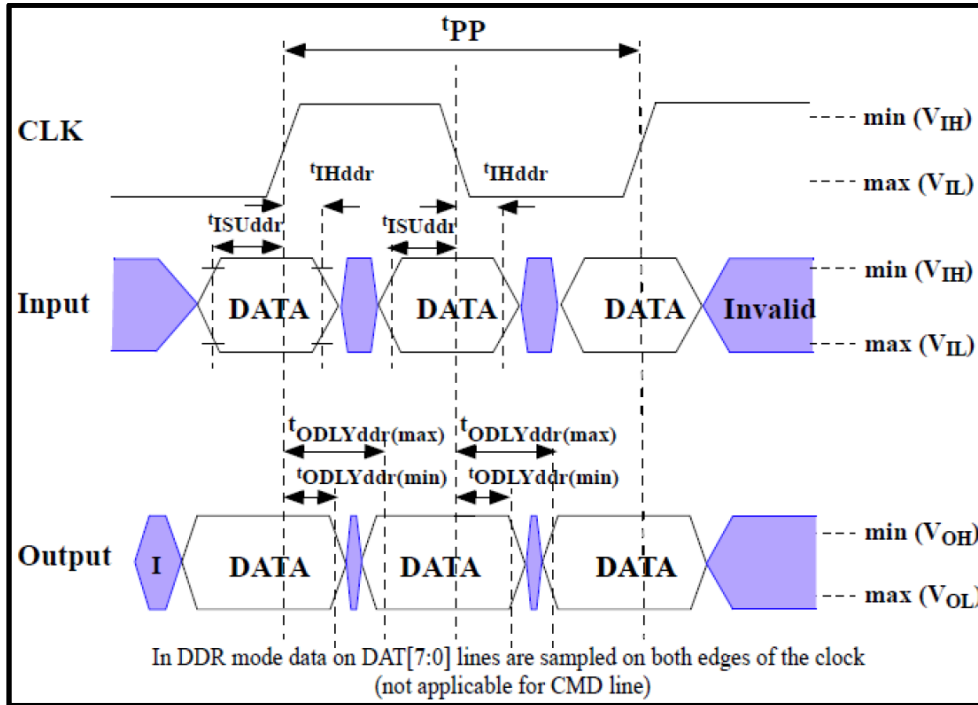

Figure 8.5 Timing Diagram; Data Input/Output in Dual Data Rate Mode

8.6.1 DUAL DATA RATE INTERFACE TIMINGS

Table 8.9 – High-speed Dual Data Rate Interface Timing

Parameter	Symbol	Min	Max.	Unit	Remark
Input CLK ¹					
Clock duty cycle		45	55	%	Includes jitter, phase noise
Input DAT (referenced to CLK-DDR mode)					
Input set-up time	t _{ISUddr}	2.5		ns	CL ≤ 20 pF
Input hold time	t _{IHddr}	2.5		ns	CL ≤ 20 pF
Output DAT (referenced to CLK-DDR mode)					
Output delay time during data transfer	t _{ODLYddr}	1.5	7	ns	CL ≤ 20 pF
Signal rise time (all signals) ²	t _{RISE}		2	ns	CL ≤ 20 pF
Signal fall time (all signals)	t _{FALL}		2	ns	CL ≤ 20 pF

Notes:

1. CLK timing is measured at 50% of VDD.
2. Inputs CMD, DAT rise and fall times are measured by min (V_{IH}) and max (V_{IL}), and outputs CMD, DAT rise and fall times are measured by min (V_{OH}) and max (V_{OL})

8.7 BUS TIMING SPECIFICATION IN HS400 MODE
DUAL DATA RATE INTERFACE TIMINGS

The CMD input timing for HS400 mode is the same as CMD input timing for HS200 mode. Figure 8.6 and Table 8.10 show Device input timing.

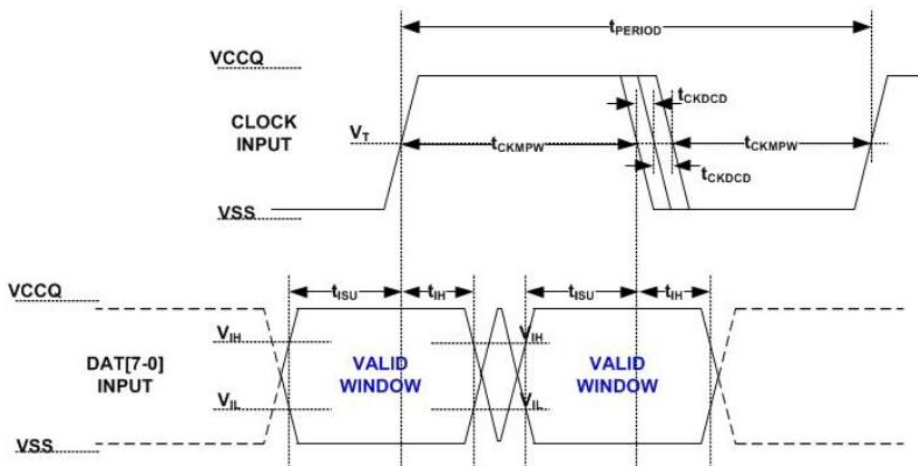
Notes:

1. t_{ISU} and t_{IH} measured at $V_{IL(max.)}$ and $V_{IH(min.)}$.
2. V_{IH} denotes $V_{IH(min.)}$ and V_{IL} denotes $V_{IL(max.)}$.

Figure 8.6 HS400 Device Data Input Timing

Table 8.10 – HS400 Device input timing

Parameter	Symbol	Min	Max	Unit	Remark
Input CLK					
Cycle time data transfer mode	t_{PERIOD}	5			200MHz (Max), between rising edges With respect to V_T .
Slew rate	SR	1.125		V/ns	With respect to V_{IH}/V_{IL} .
Duty cycle distortion	t_{CKDCD}	0.0	0.3	ns	Allowable deviation from an ideal 50% duty cycle. With respect to V_T . Includes jitter, phase
Minimum pulse width	t_{CKMPW}	2.2		ns	With respect to V_T .
Input DAT (referenced to CLK)					
Input set-up time	t_{ISUddr}	0.4		ns	$C_{Device} \leq 6pF$ With respect to V_{IH}/V_{IL} .
Input hold time	t_{IHddr}	0.4		ns	$C_{Device} \leq 6pF$ With respect to V_{IH}/V_{IL} .
Slew rate	SR	1.125		V/ns	With respect to V_{IH}/V_{IL} .

8.7.1 HS400 DEVICE OUTPUT TIMING

The Data Strobe is used to read data in HS400 mode. The Data Strobe is toggled only during data read or CRC status response

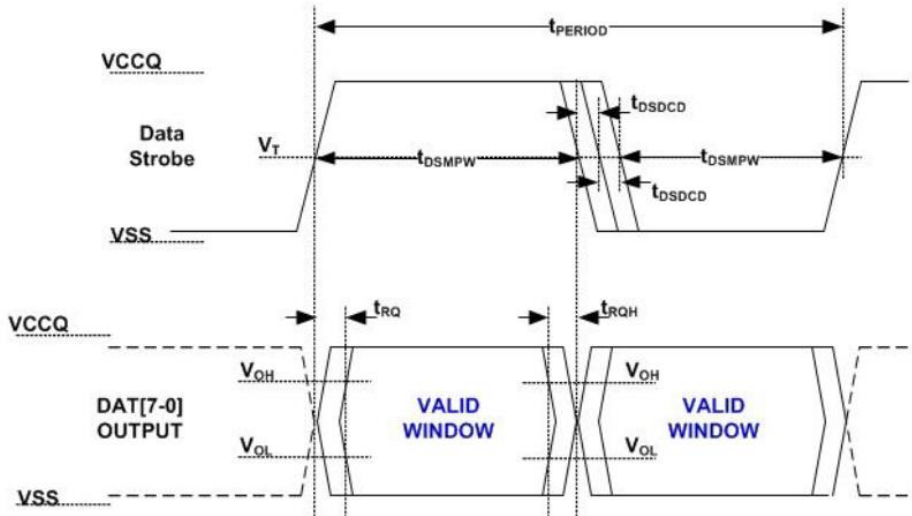

Figure 8.7 HS400 Device Output Timing

Table 8.11 – HS400 Device Output timing

Parameter	Symbol	Min	Max	Unit	Remark
Data Strobe					
Cycle time data transfer mode	tPERIOD	5			200MHz(Max), between rising edges With respect to VT
Slew rate	SR	1.125		V/ns	With respect to VOH/VOL and HS400 reference load
Duty cycle distortion	tDSDCD	0.0	0.2	ns	Allowable deviation from the input CLK duty cycle distortion (tCKDCD) With respect to VT Includes jitter, phase noise
Minimum pulse width	tDSMPW	2.0		ns	With respect to VT
Read pre-amble	tRPRE	0.4	-	tPERIOD	Max value is specified by manufacturer. Value up to infinite is valid
Read post-amble	tRPST	0.4	-	tPERIOD	Max value is specified by manufacturer. Value up to infinite is valid
Output DAT (referenced to Data Strobe)					
Output skew	tRQ		0.4	ns	With respect to VOH/VOL and HS400 reference load
Output hold skew	tRQH		0.4	ns	With respect to VOH/VOL and HS400 reference load.
Slew rate	SR	1.125		V/ns	With respect to VOH/VOL and HS400 reference load

NOTE 1: Measured with HS400 reference load

Table 8.12 – HS400 Capacitance

Parameter	Symbol	Min	Type	Max	Unit	Remark
Pull-up resistance for CMD	RCMD	4.7		100(1)	Kohm	
Pull-up resistance for DAT0-7	RDAT	10		100(1)	Kohm	
Pull-down resistance for Data Strobe	RDS	10		100(1)	Kohm	
Internal pull up resistance DAT1-DAT7	Rint	10		150	Kohm	
Single Device capacitance	CDevice			6	pF	

9. PACKAGE TYPE INFORMATION

9.1 100-ball FBGA Package (Q)

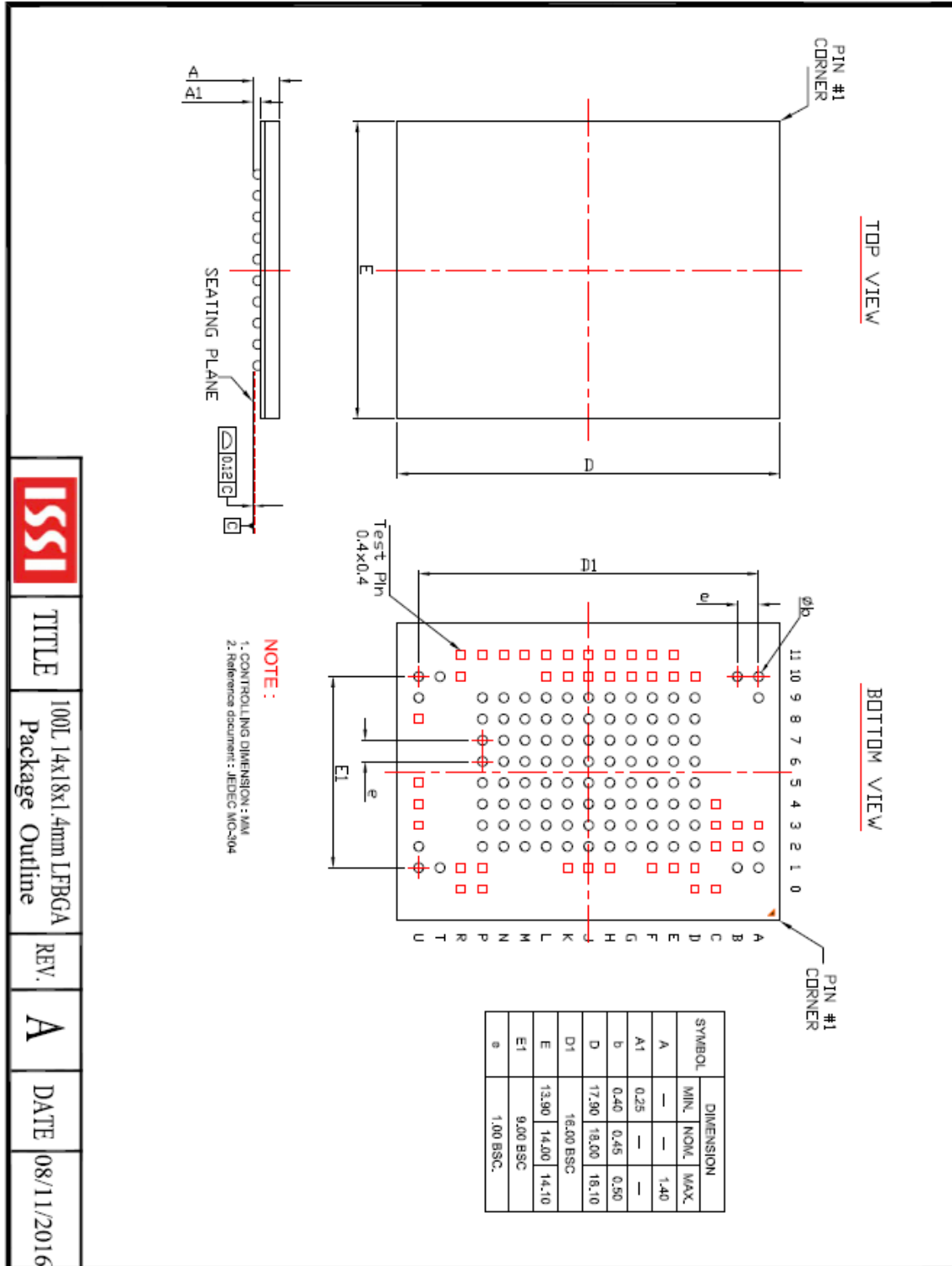

	TITLE	100L 14x18x1.4mm LFBGA Package Outline	REV.	A	DATE	08/11/2016
--	-------	----------------------------------------	------	---	------	------------

9.2 153-BALL FBGA Package (C)

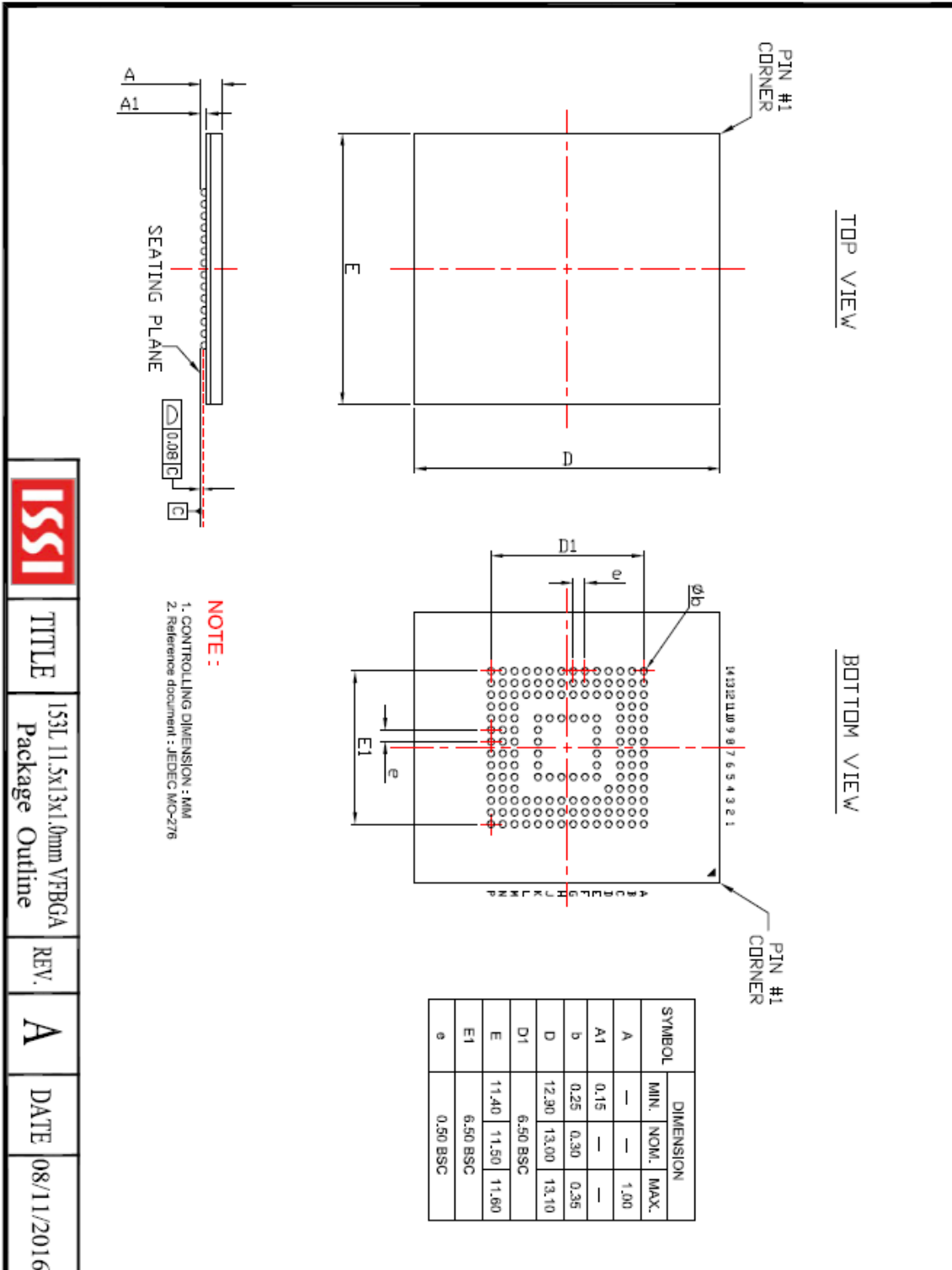

	TITLE	REV.	DATE
	ISSI	A	08/11/2016
	153L 11.5x13x1.0mm VFBGA Package Outline		

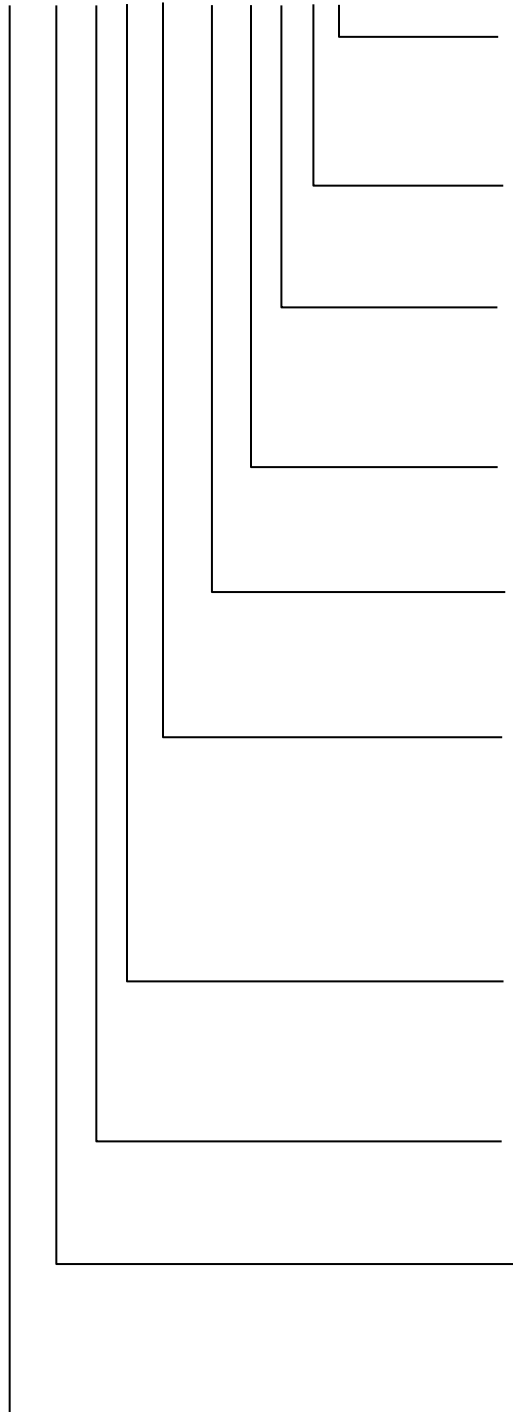
10. ORDERING INFORMATION – Valid Part Numbers
IS 21 E S 16G _ - J Q L I

TEMPERATURE RANGE

I = Industrial (-40°C to +85°C)
 A1 = Automotive Grade (-40°C to +85°C)
 A2 = Automotive Grade (-40°C to +105°C)

PACKAGING CONTENT

L = RoHS compliant

PACKAGE Type

C = 153-ball FBGA
 Q = 100-ball FBGA

OPTION

J = Standard (Boot Partition Size: 4MB)
 B = Boot Partition Size: 16MB

Generation.

Blank = 1st Gen.

eMMC Density

16G = 16 GB

INTERFACE

S = eMMC 5.0
 F = eMMC 5.1

Technology

E = ISSI eMMC with MLC NAND

Product Family

21 = Managed NAND
 22 = Automotive Managed NAND

BASE PART NUMBER

IS = Integrated Silicon Solution Inc.



Density	Interface	NAND Flash	Package	Temp. Grade	Order Part Number
16GB	eMMC 5.0	128Gbx1	100 FBGA	I-Temp.	IS21ES16G-JQLI
					IS21ES16G-BQLI
				Automotive, A1 ⁽¹⁾	IS22ES16G-JQLA1
					IS22ES16G-BQLA1
				Automotive, A2 ⁽¹⁾	IS22ES16G-JQLA2
					IS22ES16G-BQLA2
			153 FBGA	I-Temp.	IS21ES16G-JCLI
					IS22ES16G-BCLI
				Automotive, A1 ⁽¹⁾	IS22ES16G-JCLA1
					IS22ES16G-BCLA1
				Automotive, A2 ⁽¹⁾	IS22ES16G-JCLA2
					IS22ES16G-BCLA2

Note:

1. A1,A2: Meets AEC-Q100 requirements with PPAP.



Компания «ЭлектроПласт» предлагает заключение долгосрочных отношений при поставках импортных электронных компонентов на взаимовыгодных условиях!

Наши преимущества:

- Оперативные поставки широкого спектра электронных компонентов отечественного и импортного производства напрямую от производителей и с крупнейших мировых складов;
- Поставка более 17-ти миллионов наименований электронных компонентов;
- Поставка сложных, дефицитных, либо снятых с производства позиций;
- Оперативные сроки поставки под заказ (от 5 рабочих дней);
- Экспресс доставка в любую точку России;
- Техническая поддержка проекта, помощь в подборе аналогов, поставка прототипов;
- Система менеджмента качества сертифицирована по Международному стандарту ISO 9001;
- Лицензия ФСБ на осуществление работ с использованием сведений, составляющих государственную тайну;
- Поставка специализированных компонентов (Xilinx, Altera, Analog Devices, Intersil, Interpoint, Microsemi, Aeroflex, Peregrine, Syfer, Eurofarad, Texas Instrument, Miteq, Cobham, E2V, MA-COM, Hittite, Mini-Circuits, General Dynamics и др.);

Помимо этого, одним из направлений компании «ЭлектроПласт» является направление «Источники питания». Мы предлагаем Вам помощь Конструкторского отдела:

- Подбор оптимального решения, техническое обоснование при выборе компонента;
- Подбор аналогов;
- Консультации по применению компонента;
- Поставка образцов и прототипов;
- Техническая поддержка проекта;
- Защита от снятия компонента с производства.



Как с нами связаться

Телефон: 8 (812) 309 58 32 (многоканальный)

Факс: 8 (812) 320-02-42

Электронная почта: org@eplast1.ru

Адрес: 198099, г. Санкт-Петербург, ул. Калинина, дом 2, корпус 4, литера А.