

SPECIFICATIONS
MAKE-BEFORE-BREAK

MATERIALS:
 ACTUATOR- POM, UL94HB BLACK
 TERMINAL BOARD- PHENOLIC LAMINATED SHEET, UL94HB, NATURAL
 FRAME- STEEL, NICKEL PLATE
 TERMINAL/FIXED CONTACT- COPPER ALLOY, GOLD OR SILVER OVER NICKEL PLATE
 MOVING CONTACT- COPPER ALLOY, GOLD OR SILVER OVER NICKLE PLATE
 DETENT BALL- STEEL
 COIL SPRING- GALVANIZED SPRING WIRE
 LEVER,(K SERIES ONLY)- ALUMINUM
 SEAL- EPOXY

ELECTRICAL:
 CONTACT RATING- .4VA@20VDC OR PEAK AC (GOLD); 300mA@125V AC (SILVER)
 INITIAL CONTACT RESISTANCE- 30 milliohm max.
 FINAL CONTACT RESISTANCE- 100 milliohm max. (AFTER TEST)
 INSULTAIION RESISTANCE- 1,000 Megohms min.
 DIELECTRIC STRENGTH- 500V RMS@SEA LEVEL
 LIFE EXPECTANCY- 15,000 CYCLES MIN.

MECHANICAL:
 ACTUATION FORCE- 600+/-300 GRAMS
 TRAVEL- SEE P/N TABLE

ENVIRONMENTAL:
 OPERATING TEMPERATURE- -20 TO +85 DEGREES C
 STORAGE TEMPERATURE- -40 TO +100 DEGREES C
 RESISTANCE TO SOLDER HEAT PER 109-202, CONDITION B
 SOLDERABILITY PER EIA-364-52, CLASS 2, CATEGORY 1, 95% MIN COVERAGE

- △ 1 COUNTRY OF ORIGIN AND TE CONNECTIVITY LOGO LOCATED APPROXIMATELY AS SHOWN
- 2 ALL MATERIALS AND FINISHES SHALL COMPLY WITH EU DIRECTIVE 2002/95/EC OF 27JAN2003 (ROHS)
- △ 3 ANTI SOLDER WICK SEAL AT TERMINAL TO BOARD INTERFACE
- 4 ALL PERFORMANCE TESTING WAS DONE IN ACCORDANCE TO TE CONNECTIVITY SPECIFICATION 102-2469
- △ 5 OBSOLETE PARTS: OBSOLETE CIS STREAMLINING PER D.RENAUD/D.SINISI
- △ 6 FOR TE PART NO. 1-1825255-1, LEVER LENGTH IS 15.0 [.591]

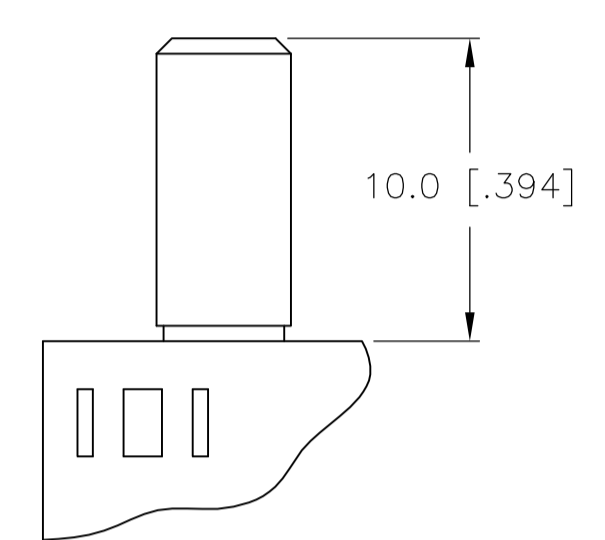
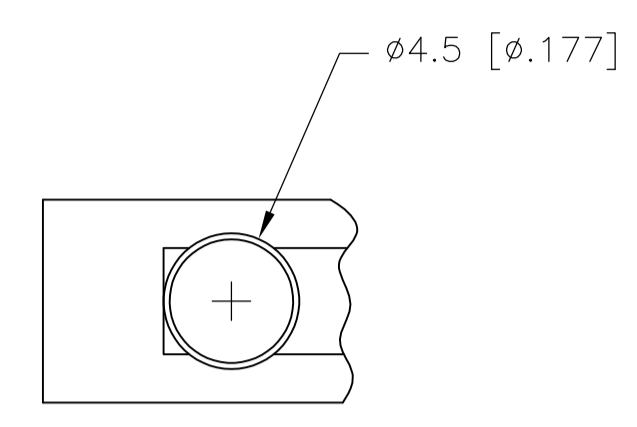
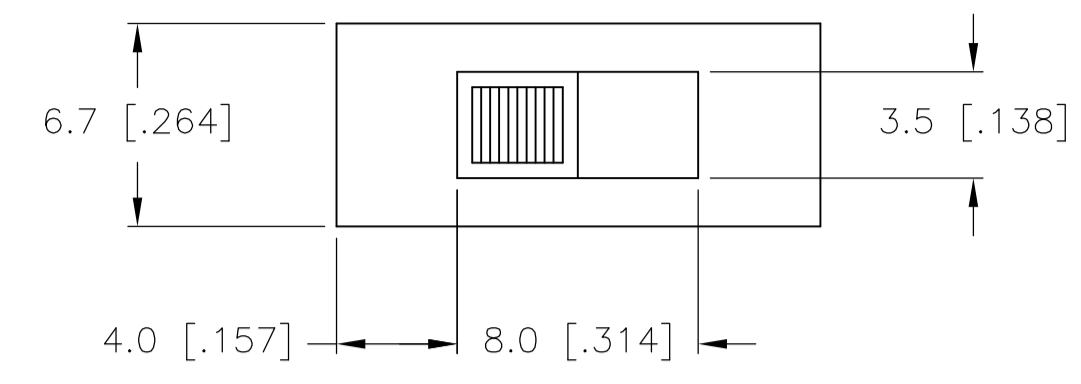

MHS-122K LEVER

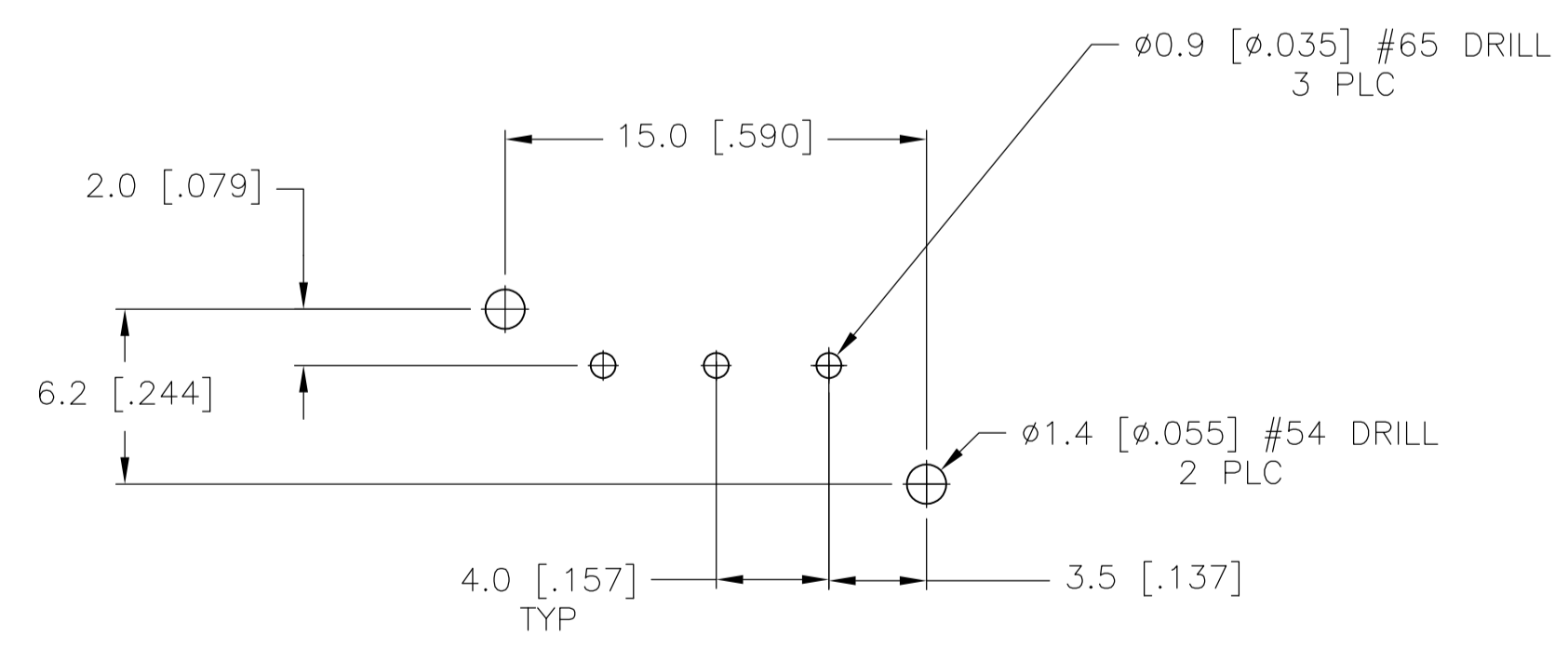
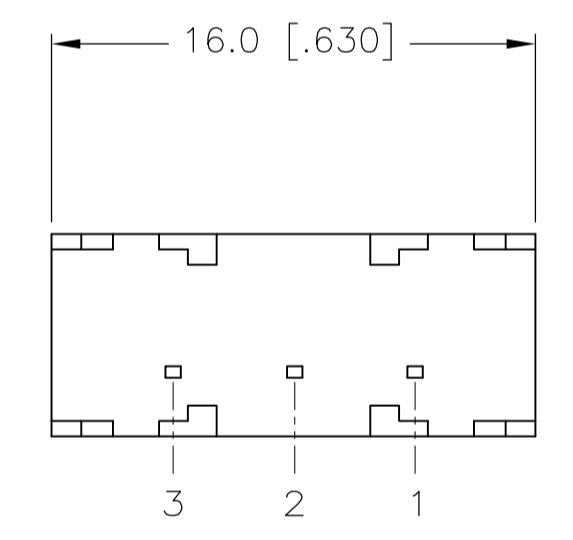
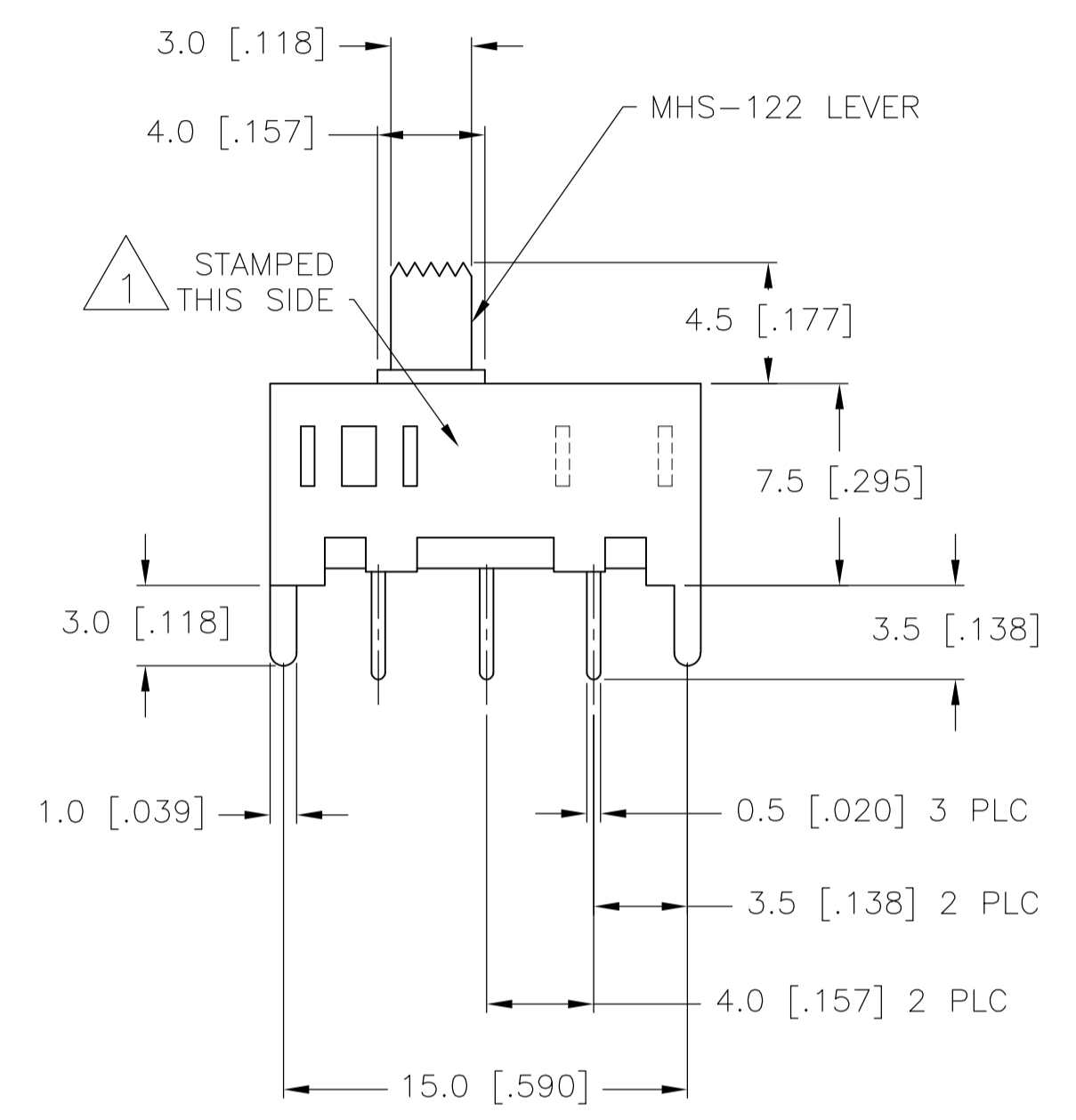
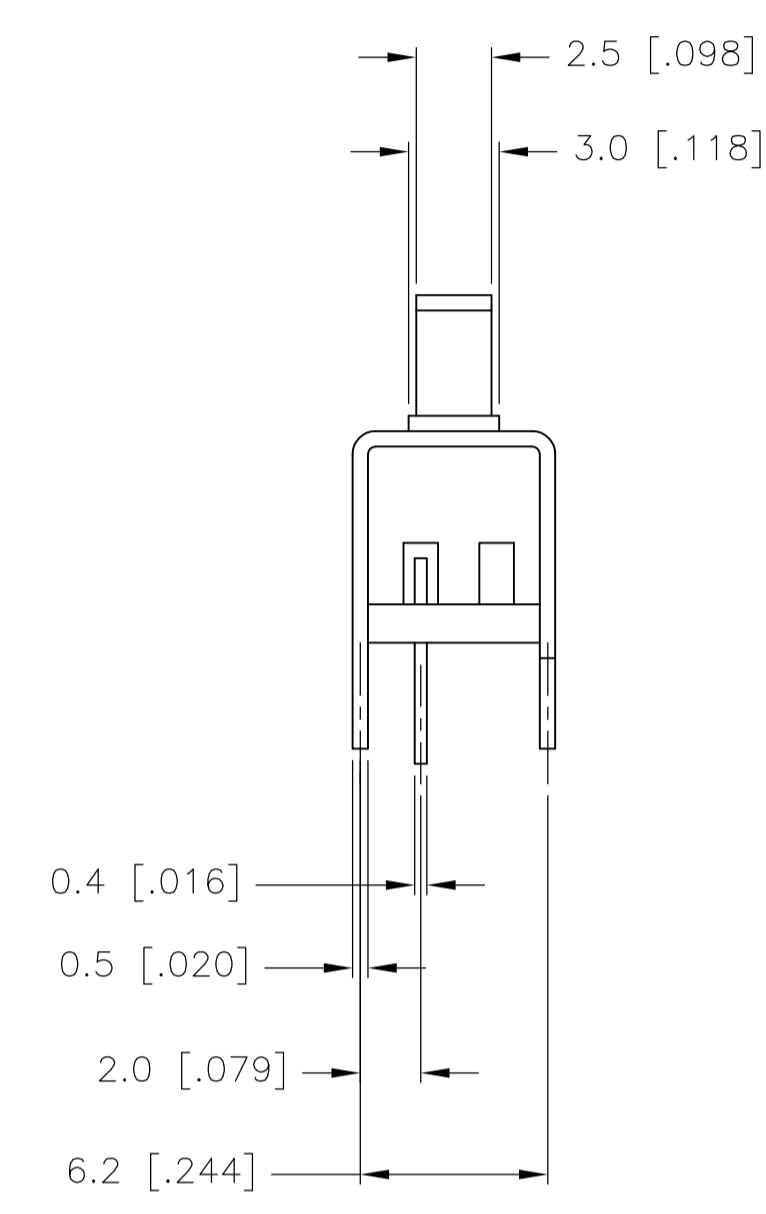

RECOMMENDED BOARD LAYOUT
PC LAYOUT TOLERANCE: ±.002

MHS-122 SERIES SWITCH

△ 6	1-1825255-1	-	SPDT	2.00	SILVER	2-1	-	OFF	-	2-3	-
△ 5	1-1825255-0	MHS133KG04	SP3T	2.00	GOLD	-	2-1	-	2-3	-	2-4
	1825255-9	MHS133K04	SP3T	2.00	SILVER	-	2-1	-	2-3	-	2-4
	1825255-8	MHS133G04	SP3T	2.00	GOLD	-	2-1	-	2-3	-	2-4
	1825255-7	MHS13304	SP3T	2.00	SILVER	-	2-1	-	2-3	-	2-4
	-	MHS123KG04	SPDT	2.00	GOLD	2-1	-	OFF	-	2-3	-
	1825255-6	MHS123K04	SPDT	2.00	SILVER	2-1	-	OFF	-	2-3	-
	-	MHS123G04	SPDT	2.00	GOLD	2-1	-	OFF	-	2-3	-
	1825255-5	MHS12304	SPDT	2.00	SILVER	2-1	-	OFF	-	2-3	-
△ 5	1825255-4	MHS122KG04	SPDT	4.00	GOLD	2-1	-	NONE	-	2-3	-
	1825255-3	MHS122K04	SPDT	4.00	SILVER	2-1	-	NONE	-	2-3	-
	1825255-2	MHS122G04	SPDT	4.00	GOLD	2-1	-	NONE	-	2-3	-
	1825255-1	MHS12204	SPDT	4.00	SILVER	2-1	-	NONE	-	2-3	-
	PART NO.	T&B PART NO.	TYPE	TRAVEL	PLATING						

TERMINALS CONNECTED WHEN SLIDE IS IN POSITION SHOWN.

THIS DRAWING IS A CONTROLLED DOCUMENT.		DIN R BROWN 21DEC05	TE Connectivity	
DIMENSIONS: mm [INCHES]		CHK M SARVER 21DEC05		
TOLERANCES UNLESS OTHERWISE SPECIFIED:		APVD M SARVER 21DEC05	NAME	
0 PLC ± - 1 PLC ± 0.3 [.012] 2 PLC ± - 3 PLC ± - 4 PLC ± - ANGLES ± 1°		PRODUCT SPEC		SLIDE SWITCH, MHS SERIES, SINGLE POLE, VERTICAL
MATERIAL		APPLICATION SPEC		RESTRICTED TO
FINISH		WEIGHT		SIZE CAGE CODE DRAWING NO. A1 00779 1825255
		CUSTOMER DRAWING		SCALE 4:1 SHEET 1 OF 2 REV A4

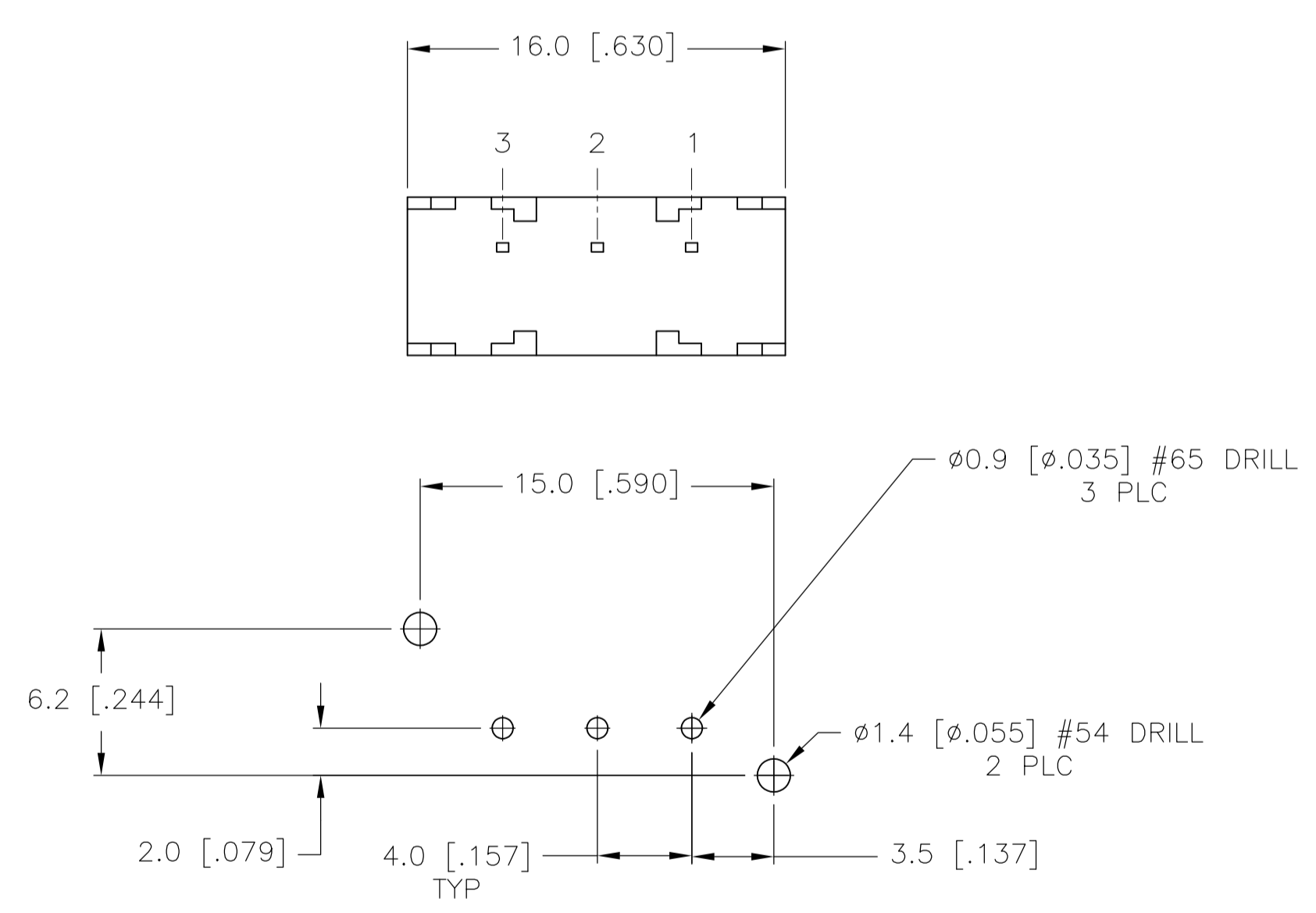
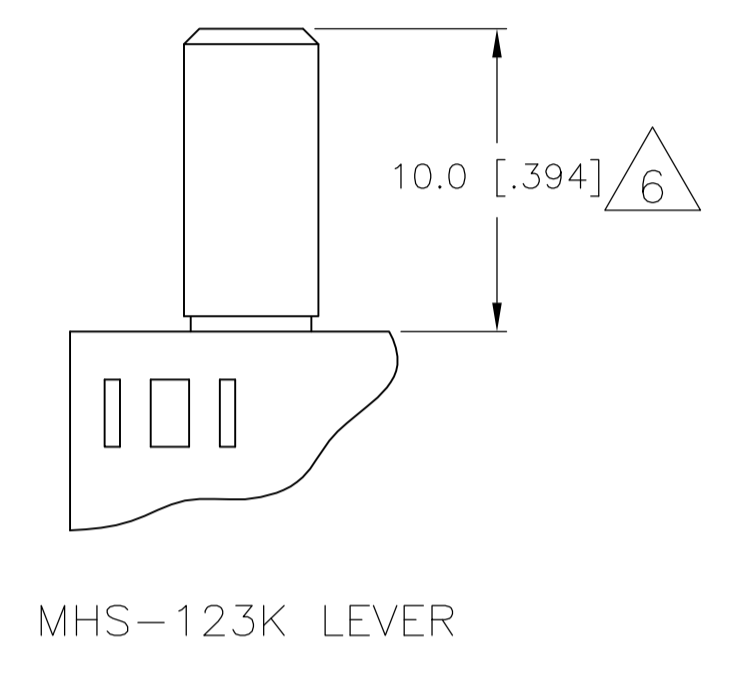
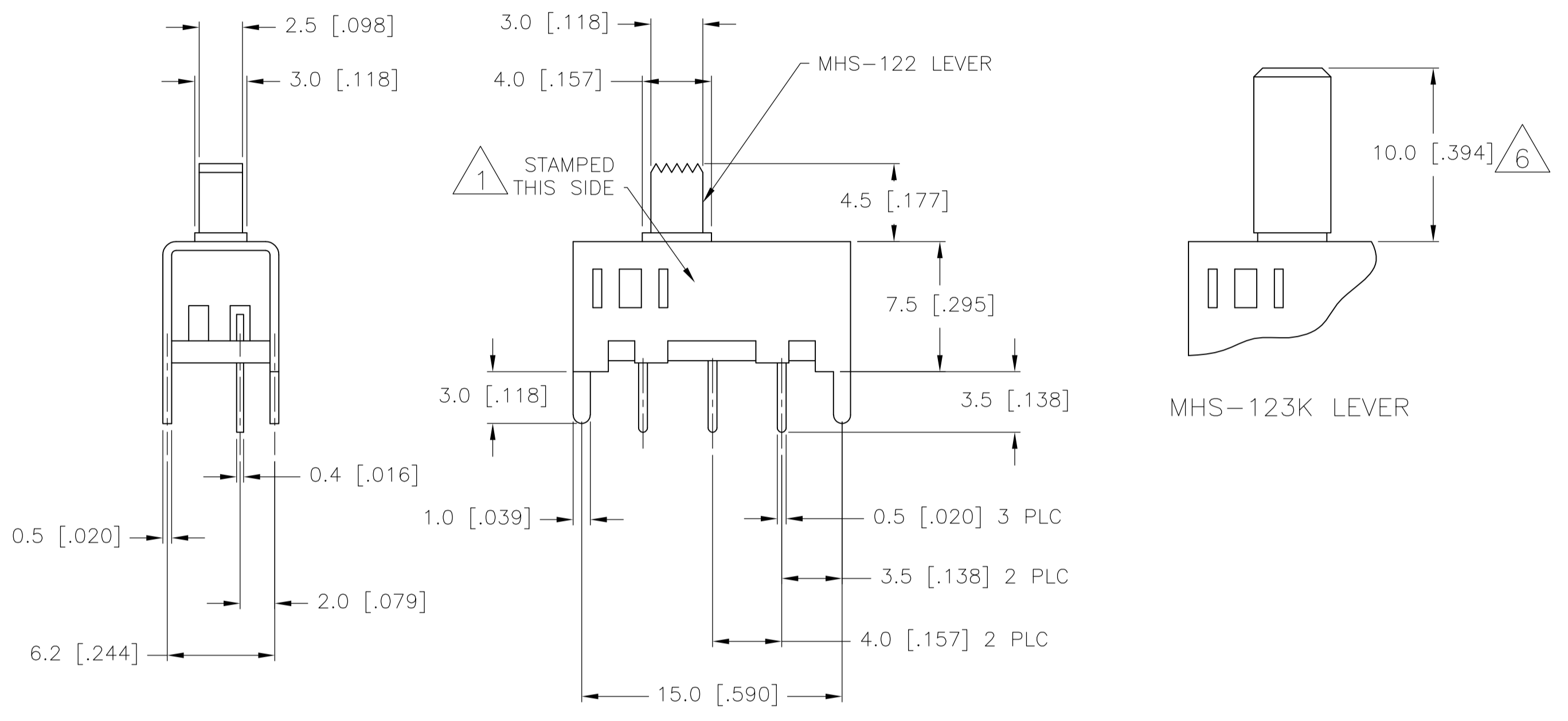
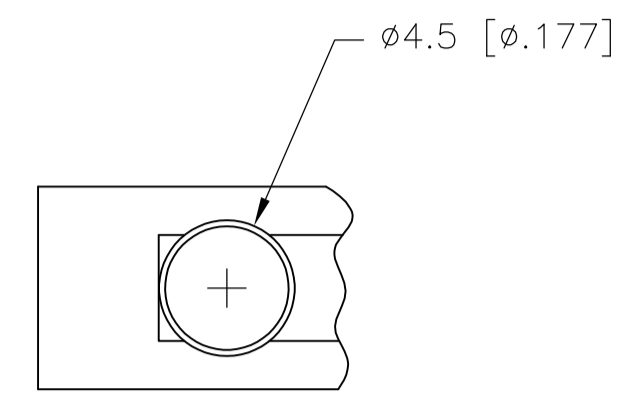
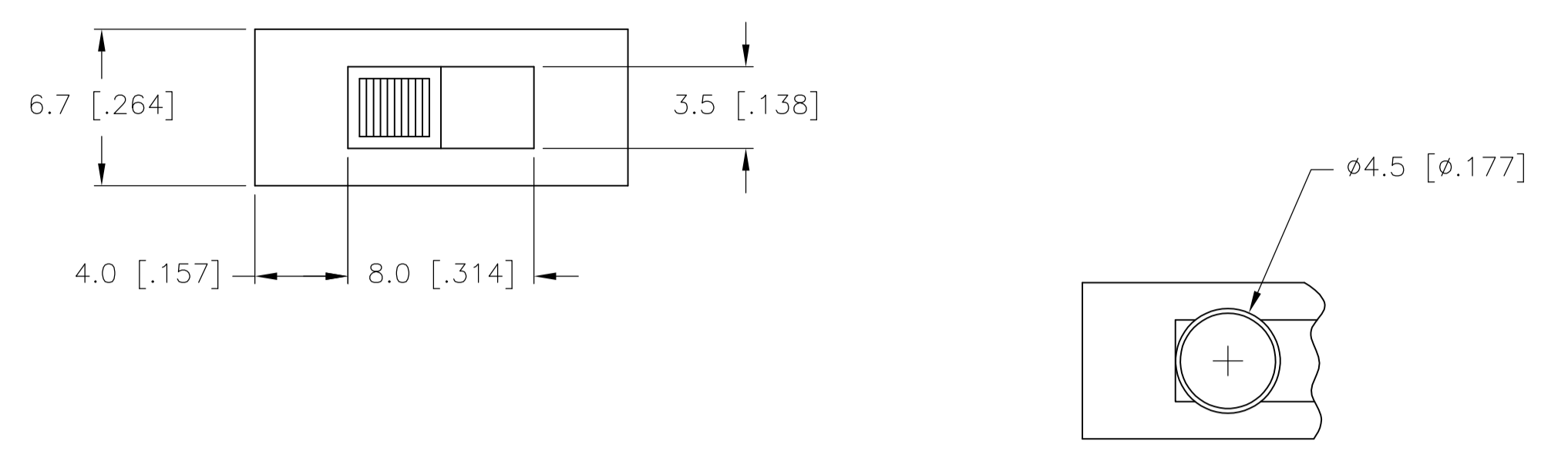

RECOMMENDED BOARD LAYOUT
PC LAYOUT TOLERANCE: ±.002

MHS-123 SERIES SWITCH

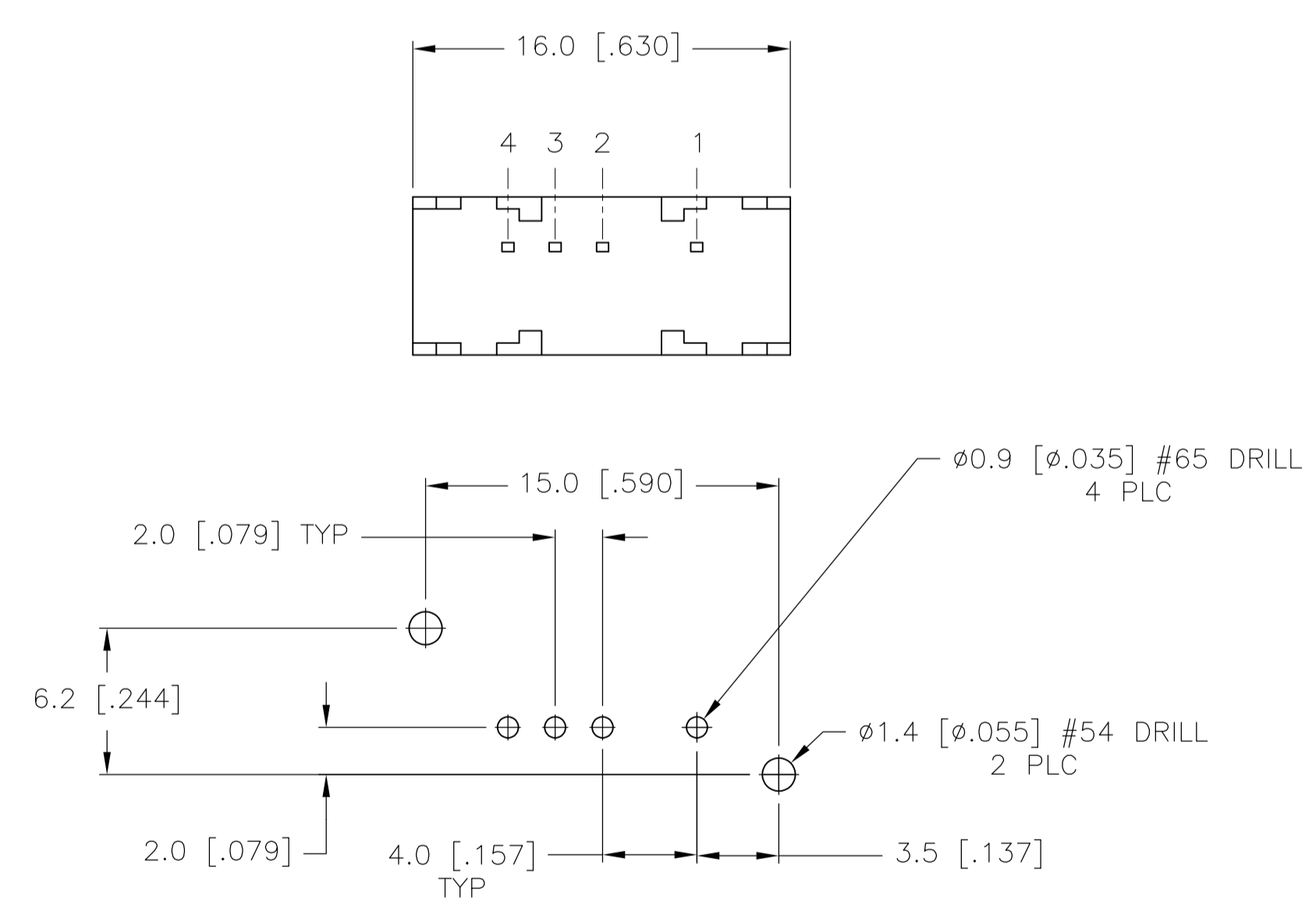
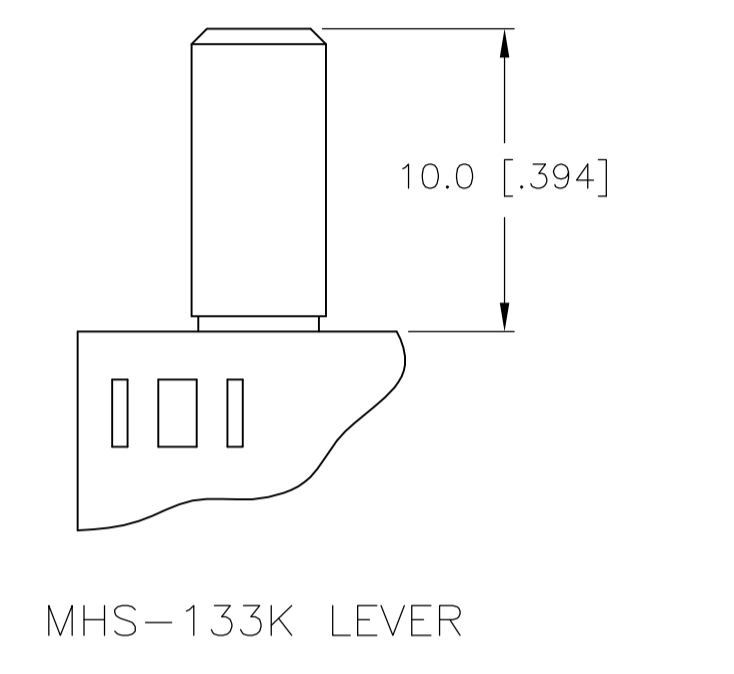
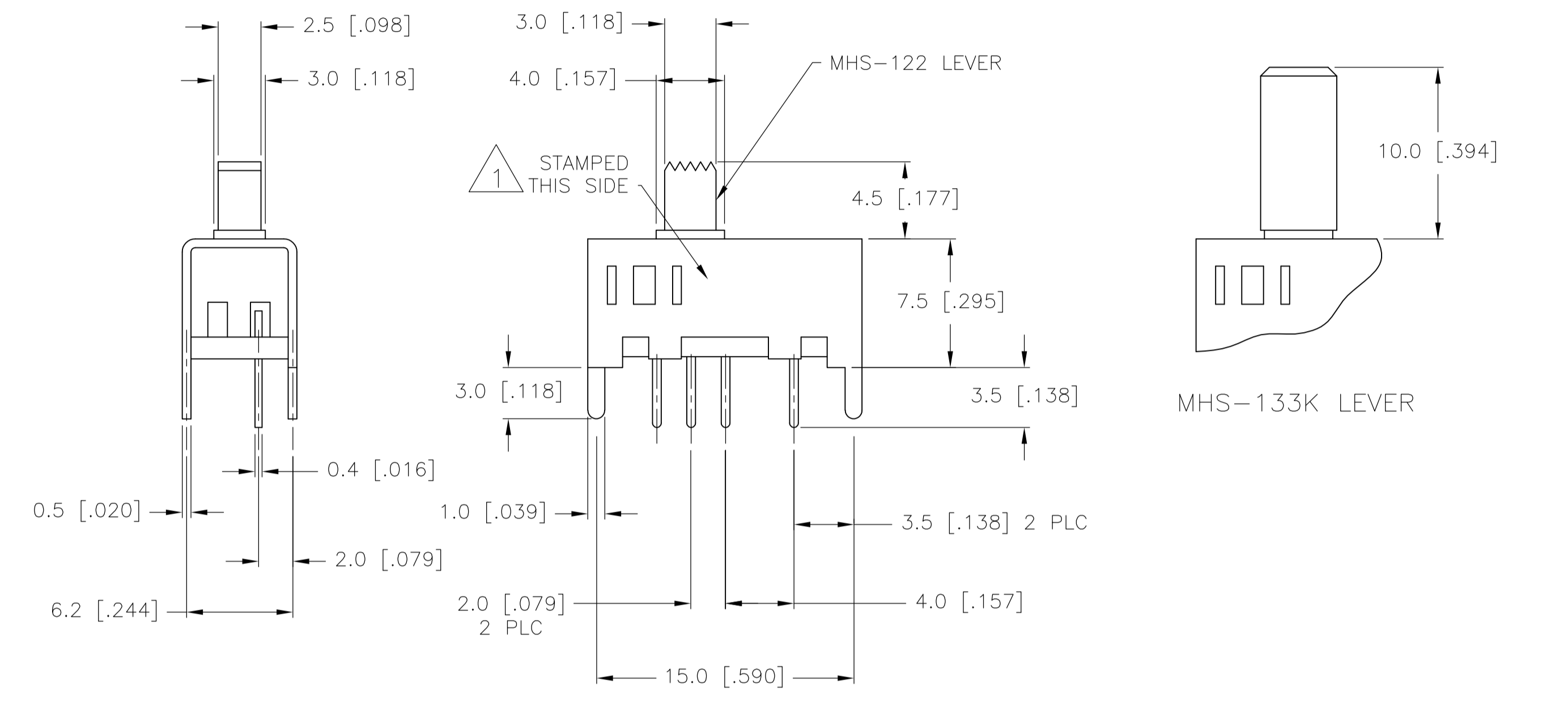
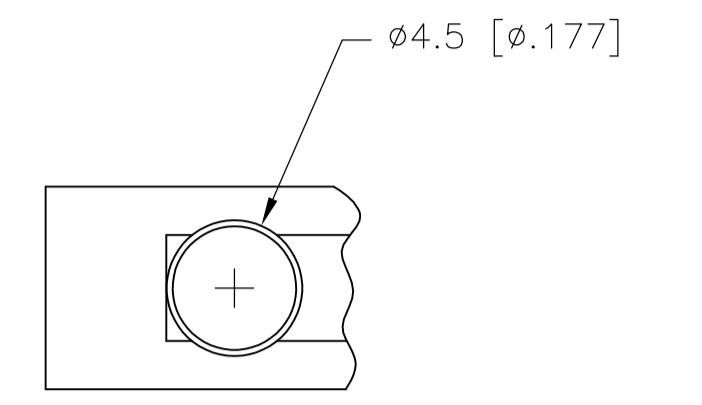
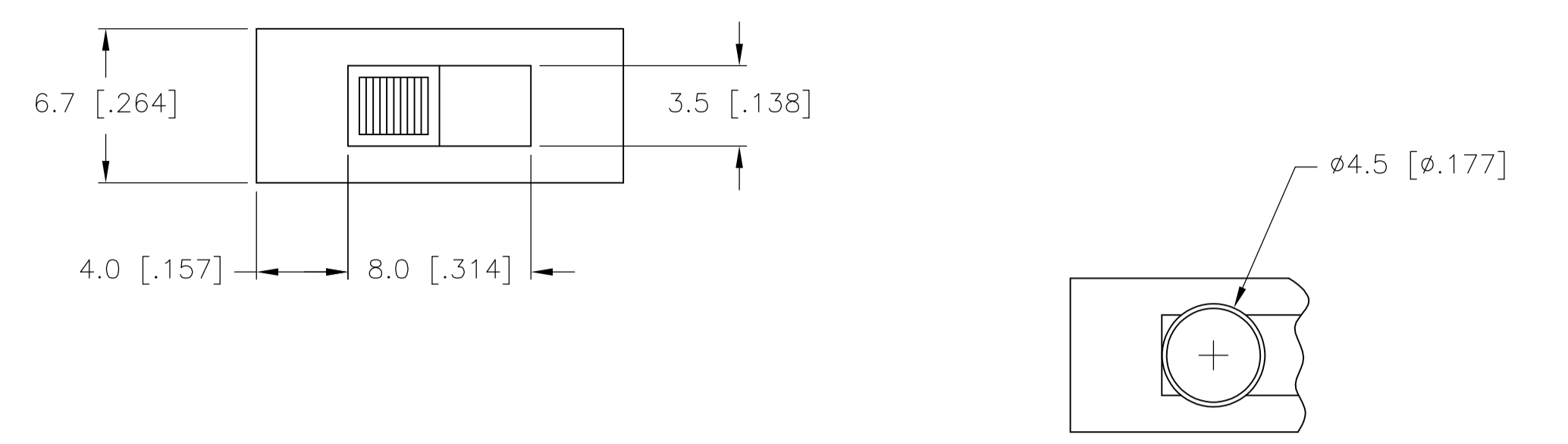

RECOMMENDED BOARD LAYOUT
PC LAYOUT TOLERANCE: ±.002

MHS-133 SERIES SWITCH

THIS DRAWING IS A CONTROLLED DOCUMENT.		DIN R BROWN 21DEC05	TE Connectivity
DIMENSIONS: mm [INCHES]		CHK M SARVER 21DEC05	
TOLERANCES UNLESS OTHERWISE SPECIFIED:		APP'D M SARVER 21DEC05	NAME
0 PLC ± -	1 PLC ± 0.3 [.012]	PRODUCT SPEC	SLIDE SWITCH, MHS SERIES, SINGLE POLE, VERTICAL
2 PLC ± -	3 PLC ± -	APPLICATION SPEC	
4 PLC ± -	ANGLES ± 1'	SIZE	A1
MATERIAL	FINISH	WEIGHT	00779 1825255
		CUSTOMER DRAWING	SCALE 4:1 SHEET 2 OF 2 REV A4



Компания «ЭлектроПласт» предлагает заключение долгосрочных отношений при поставках импортных электронных компонентов на взаимовыгодных условиях!

Наши преимущества:

- Оперативные поставки широкого спектра электронных компонентов отечественного и импортного производства напрямую от производителей и с крупнейших мировых складов;
- Поставка более 17-ти миллионов наименований электронных компонентов;
- Поставка сложных, дефицитных, либо снятых с производства позиций;
- Оперативные сроки поставки под заказ (от 5 рабочих дней);
- Экспресс доставка в любую точку России;
- Техническая поддержка проекта, помощь в подборе аналогов, поставка прототипов;
- Система менеджмента качества сертифицирована по Международному стандарту ISO 9001;
- Лицензия ФСБ на осуществление работ с использованием сведений, составляющих государственную тайну;
- Поставка специализированных компонентов (Xilinx, Altera, Analog Devices, Intersil, Interpoint, Microsemi, Aeroflex, Peregrine, Syfer, Eurofarad, Texas Instrument, Miteq, Cobham, E2V, MA-COM, Hittite, Mini-Circuits, General Dynamics и др.);

Помимо этого, одним из направлений компании «ЭлектроПласт» является направление «Источники питания». Мы предлагаем Вам помощь Конструкторского отдела:

- Подбор оптимального решения, техническое обоснование при выборе компонента;
- Подбор аналогов;
- Консультации по применению компонента;
- Поставка образцов и прототипов;
- Техническая поддержка проекта;
- Защита от снятия компонента с производства.



Как с нами связаться

Телефон: 8 (812) 309 58 32 (многоканальный)

Факс: 8 (812) 320-02-42

Электронная почта: org@eplast1.ru

Адрес: 198099, г. Санкт-Петербург, ул. Калинина, дом 2, корпус 4, литера А.