

CBTL04083A; CBTL04083B

3.3 V, 4 differential channel, 2 : 1 multiplexer/demultiplexer switch for PCI Express Gen3

Rev. 4 — 25 June 2012

Product data sheet

1. General description

CBTL04083A/B is a 4 differential channel, 2-to-1 multiplexer/demultiplexer switch for PCI Express Generation 3 (Gen3) applications. The CBTL04083A/B can switch four differential signals to one of two locations. Using a unique design technique, NXP has minimized the impedance of the switch such that the attenuation observed through the switch is negligible, and also minimized the channel-to-channel skew as well as channel-to-channel crosstalk, as required by the high-speed serial interface. CBTL04083A/B allows expansion of existing high speed ports for extremely low power.

The device's pin out are optimized to match different application layouts. CBTL04083A has input and output pins on the opposite of the package, and is suitable for edge connector(s) with different signal sources on the motherboard. CBTL04083B has outputs on both sides of the package, and the device can be placed between two connectors to multiplex differential signals from a controller. Please refer to [Section 8](#) for layout examples.

2. Features and benefits

- 4 differential channel, 2 : 1 multiplexer/demultiplexer
- High-speed signal switching for 8.0 Gbit/s PCIe Gen3 speed
- Low intra-pair skew: 5 ps typical
- Low inter-pair skew: 35 ps maximum
- High bandwidth:
 - ◆ -3 dB at 8.3 GHz for CBTL04083A
 - ◆ -3 dB at 8.0 GHz for CBTL04083B
- Low crosstalk: -29 dB at 4 GHz
- Low insertion loss
 - ◆ -0.5 dB at 100 MHz
 - ◆ -1.3 dB at 4 GHz
- Low off-state isolation: -20 dB at 4 GHz
- Low return loss: -14 dB at 4 GHz
- V_{DD} operating range: 3.3 V \pm 10 %
- Dual shutdown pins for channel 0/1 and 2/3 independently to minimize power consumption
- ESD tolerance:
 - ◆ 2000 V HBM
 - ◆ 1000 V CDM
- HVQFN42 package



3. Applications

- Routing of high-speed differential signals with low signal attenuation
 - ◆ PCIe Gen3
 - ◆ DisplayPort 1.2
 - ◆ USB 3.0
 - ◆ SATA 6 Gbit/s

4. Ordering information

Table 1. Ordering information

Type number	Package		
	Name	Description	Version
CBTL04083ABS ^[1]	HVQFN42	plastic thermal enhanced very thin quad flat package; no leads; 42 terminals; body 3.5 × 9 × 0.85 mm ^[3]	SOT1144-1
CBTL04083BBS ^[2]	HVQFN42	plastic thermal enhanced very thin quad flat package; no leads; 42 terminals; body 3.5 × 9 × 0.85 mm ^[3]	SOT1144-1

- [1] CBTL04083ABS is available in tape and reel formats with different tape widths — 16 mm and 24 mm:
 For 16 mm tape width, order CBTL04083ABS 9352 941 24518 (“518” indicates 16 mm wide carrier tape).
 For 24 mm tape width, order CBTL04083ABS 9352 941 24558 (“558” indicates 24 mm wide carrier tape).
- [2] CBTL04083BBS is available in tape and reel formats with different tape widths — 16 mm and 24 mm:
 For 16 mm tape width, order CBTL04083BBS 9352 941 25518 (“518” indicates 16 mm wide carrier tape).
 For 24 mm tape width, order CBTL04083BBS 9352 941 25558 (“558” indicates 24 mm wide carrier tape).
- [3] Total height after printed-circuit board mounting = 1.0 mm maximum.

5. Functional diagram

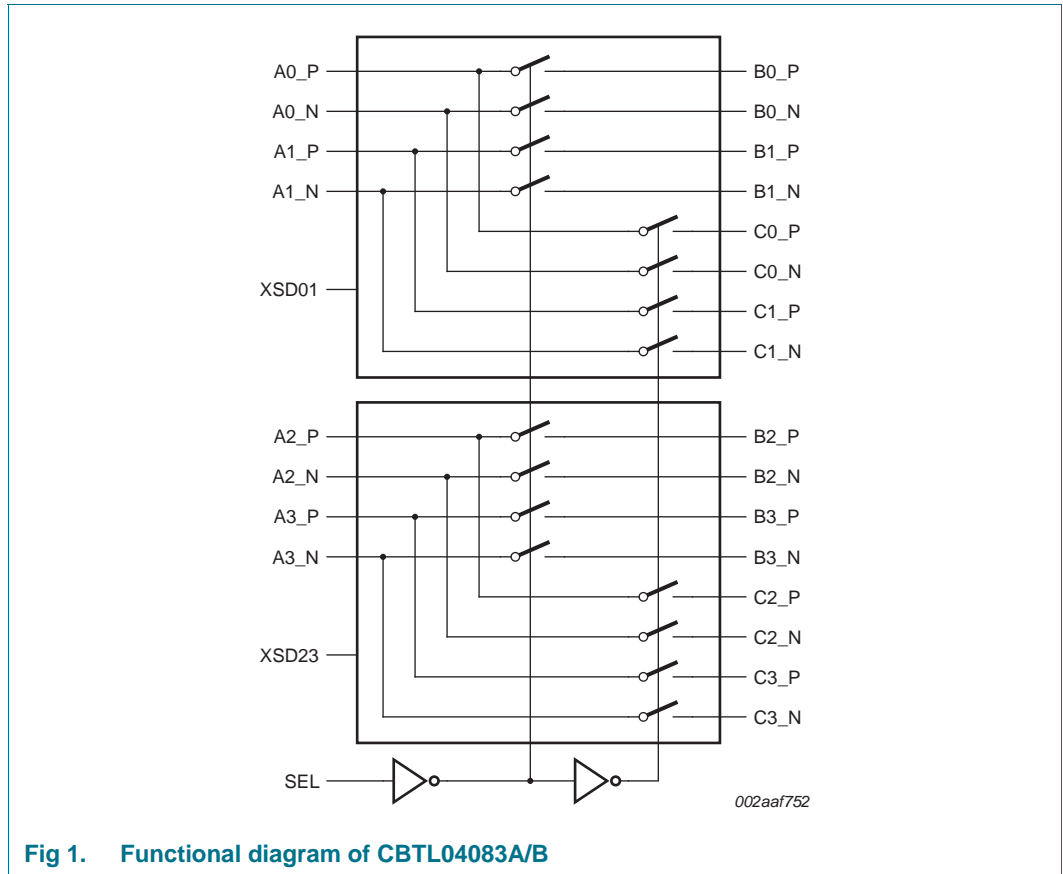

6. Pinning information

6.1 Pinning

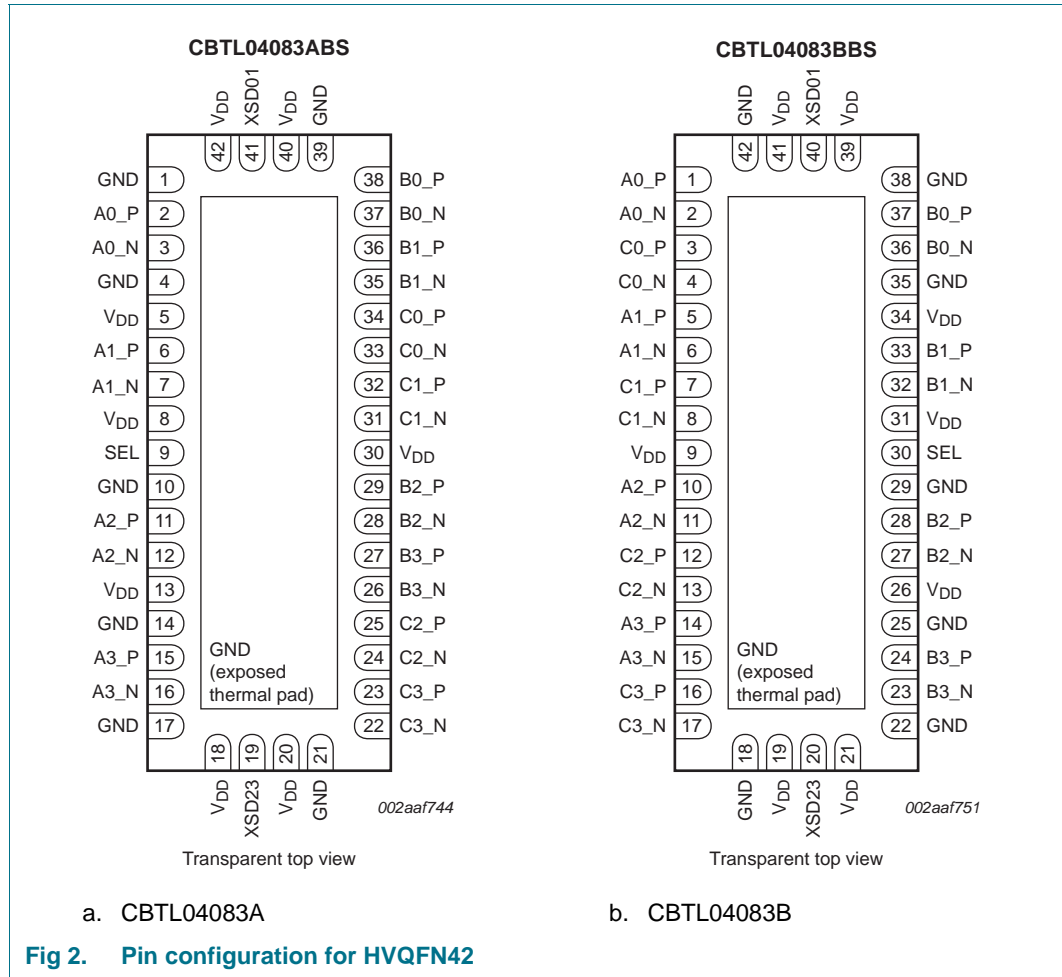

6.2 Pin description

Table 2. Pin description

Symbol	Pin		Type	Description
	CBTL04083A	CBTL04083B		
A0_P	2	1	I/O	channel 0, port A differential signal input/output
A0_N	3	2	I/O	
A1_P	6	5	I/O	channel 1, port A differential signal input/output
A1_N	7	6	I/O	
A2_P	11	10	I/O	channel 2, port A differential signal input/output
A2_N	12	11	I/O	
A3_P	15	14	I/O	channel 3, port A differential signal input/output
A3_N	16	15	I/O	

Table 2. Pin description ...continued

Symbol	Pin		Type	Description
	CBTL04083A	CBTL04083B		
B0_P	38	37	I/O	channel 0, port B differential signal input/output
B0_N	37	36	I/O	
B1_P	36	33	I/O	channel 1, port B differential signal input/output
B1_N	35	32	I/O	
B2_P	29	28	I/O	channel 2, port B differential signal input/output
B2_N	28	27	I/O	
B3_P	27	24	I/O	channel 3, port B differential signal input/output
B3_N	26	23	I/O	
C0_P	34	3	I/O	channel 0, port C differential signal input/output
C0_N	33	4	I/O	
C1_P	32	7	I/O	channel 1, port C differential signal input/output
C1_N	31	8	I/O	
C2_P	25	12	I/O	channel 2, port C differential signal input/output
C2_N	24	13	I/O	
C3_P	23	16	I/O	channel 3, port C differential signal input/output
C3_N	22	17	I/O	
SEL	9	30	CMOS single-ended input	operation mode select SEL = LOW: A → B SEL = HIGH: A → C
XSD01	41	40	CMOS single-ended input	Shutdown pin; should be driven LOW or connected to GND for normal operation. When HIGH, channel 0 and channel 1 are switched off (non-conducting high-impedance state), and supply current consumption is minimized.
XSD23	19	20	CMOS single-ended input	Shutdown pin; should be driven LOW or connected to GND for normal operation. When HIGH, channel 2 and channel 3 are switched off (non-conducting high-impedance state), and supply current consumption is minimized.
V _{DD}	5, 8, 13, 18, 20, 30, 40, 42	9, 19, 21, 26, 31, 34, 39, 41	power	positive supply voltage, 3.3 V ± 10 %
GND ^[1]	1, 4, 10, 14, 17, 21, 39, center pad	18, 22, 25, 29, 35, 38, 42, center pad	ground	supply ground

[1] HVQFN32 package die supply ground is connected to both GND pins and exposed center pad. GND pins and the exposed center pad must be connected to supply ground for proper device operation. For enhanced thermal, electrical, and board level performance, the exposed pad needs to be soldered to the board using a corresponding thermal pad on the board and for proper heat conduction through the board, thermal vias need to be incorporated in the printed-circuit board in the thermal pad region.

7. Functional description

Refer to [Figure 1 “Functional diagram of CBTL04083A/B”](#).

7.1 Function selection

Table 3. Function selection

X = Don't care.

XSD01	XSD23	SEL	Function
HIGH	-	X	An, Bn and Cn pins are high-Z, n = 0, 1
LOW	-	LOW	An to Bn, n = 0, 1
LOW	-	HIGH	An to Cn, n = 0, 1
-	HIGH	X	An, Bn and Cn pins are high-Z, n = 2, 3
-	LOW	LOW	An to Bn, n = 2, 3
-	LOW	HIGH	An to Cn, n = 2, 3

7.2 Shutdown function

The CBTL04083A/B provides a shutdown function to minimize power consumption when the application is not active, but power to the CBTL04083A/B is provided. Pin XSD01 and XSD23 (active HIGH) puts channel 0/1 and 2/3 (respectively) in high-impedance state (non-conducting) while reducing current consumption to near-zero.

Table 4. Shutdown function

XSD01	XSD23	Channel 0	Channel 1	Channel 2	Channel 3
HIGH	-	high-Z	high-Z	-	-
LOW	-	active	active	-	-
-	HIGH	-	-	high-Z	high-Z
-	LOW	-	-	active	active

8. Application design-in information

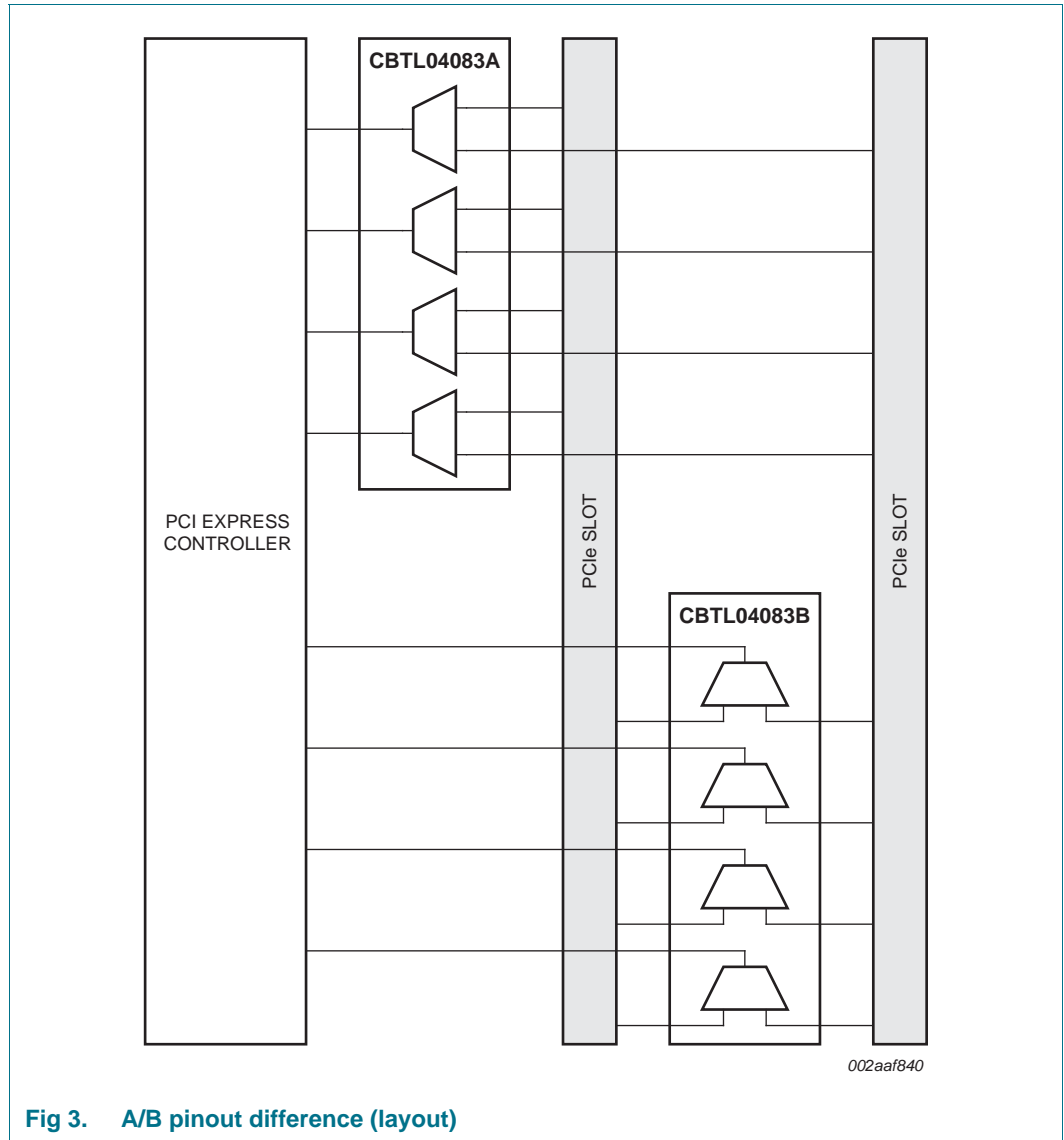

9. Limiting values

Table 5. Limiting values

In accordance with the Absolute Maximum Rating System (IEC 60134).

Symbol	Parameter	Conditions	Min	Max	Unit
V _{DD}	supply voltage		-0.3	+4.6	V
T _{case}	case temperature		-40	+85	°C
V _{ESD}	electrostatic discharge voltage	HBM	[1] -	2000	V
		CDM	[2] -	1000	V

[1] Human Body Model: ANSI/EOS/ESD-S5.1-1994, standard for ESD sensitivity testing, Human Body Model - Component level; Electrostatic Discharge Association, Rome, NY, USA.

[2] Charged Device Model: ANSI/EOS/ESD-S5.3-1-1999, standard for ESD sensitivity testing, Charged Device Model - Component level; Electrostatic Discharge Association, Rome, NY, USA.

10. Recommended operating conditions

Table 6. Recommended operating conditions

Symbol	Parameter	Conditions	Min	Typ	Max	Unit
V _{DD}	supply voltage		3.0	3.3	3.6	V
V _I	input voltage		-	-	V _{DD}	V
T _{amb}	ambient temperature	operating in free air	-40	-	+85	°C

11. Static characteristics

Table 7. Static characteristics

V_{DD} = 3.3 V ± 10 %; T_{amb} = -40 °C to +85 °C; unless otherwise specified.

Symbol	Parameter	Conditions	Min	Typ ^[1]	Max	Unit
I _{DD}	supply current	operating mode (both XSD01 and XSD23 are LOW); V _{DD} = max.	-	2.7	5	mA
		shutdown mode (both XSD01 and XSD23 are HIGH); V _{DD} = max.	-	-	1	µA
I _{IH}	HIGH-level input current	V _{DD} = max.; V _I = V _{DD}	-	-	±5 ^[2]	µA
I _{IL}	LOW-level input current	V _{DD} = max.; V _I = GND	-	-	±5 ^[2]	µA
V _{IH}	HIGH-level input voltage	SEL, XSD01, XSD23 pins	0.65V _{DD}	-	-	V
V _{IL}	LOW-level input voltage	SEL, XSD01, XSD23 pins	-0.5	-	0.35V _{DD}	V
V _I	input voltage	differential pins	-	-	2.4	V
		SEL, XSD01, XSD23 pins	-	-	V _{DD}	V
V _{IC}	common-mode input voltage		0	-	2	V
V _{ID}	differential input voltage	peak-to-peak	-	-	1.6	V

[1] Typical values are at V_{DD} = 3.3 V, T_{amb} = 25 °C, and maximum loading.

[2] Input leakage current is ±50 µA if differential pairs are pulled to HIGH and LOW.

12. Dynamic characteristics

Table 8. Dynamic characteristics

$V_{DD} = 3.3\text{ V} \pm 10\%$; $T_{amb} = -40\text{ }^{\circ}\text{C}$ to $+85\text{ }^{\circ}\text{C}$; unless otherwise specified.

Symbol	Parameter	Conditions	Min	Typ ^[1]	Max	Unit
DDNEXT	differential near-end crosstalk	adjacent channels are ON				
		f = 4 GHz	-	-29	-	dB
		f = 100 MHz	-	-45	-	dB
DDIL	differential insertion loss	channel is OFF				
		f = 4 GHz	-	-20	-	dB
		f = 100 MHz	-	-50	-	dB
		channel is ON				
		f = 4 GHz	-	-1.3	-	dB
		f = 100 MHz	-	-0.5	-	dB
DDRLL	differential return loss	f = 4 GHz		-14		dB
		f = 100 MHz	-	-24	-	dB
R _{on}	ON-state resistance	$V_{DD} = 3.3\text{ V}$; $V_I = 2\text{ V}$; $I_I = 19\text{ mA}$	-	6	-	Ω
C _{io(on)}	on-state input/output capacitance		-	1.5	-	pF
B _{-3dB}	-3 dB bandwidth	CBTL04083A	-	8.3	-	GHz
		CBTL04083B	-	8.0	-	GHz
t _{PD}	propagation delay	from left-side port to right-side port, or vice versa	-	60	-	ps
Switching characteristics						
t _{startup}	start-up time	supply voltage valid or XSD01/XSD23 going LOW to channel specified operating characteristics	-	-	10	ms
t _{PZH}	OFF-state to HIGH propagation delay		-	-	300	ns
t _{PZL}	OFF-state to LOW propagation delay		-	-	70	ns
t _{PHZ}	HIGH to OFF-state propagation delay		-	-	50	ns
t _{PLZ}	LOW to OFF-state propagation delay		-	-	50	ns
t _{sk(dif)}	differential skew time	intra-pair	-	5	-	ps
t _{sk}	skew time	inter-pair	-	-	35	ps

[1] Typical values are at $V_{DD} = 3.3\text{ V}$; $T_{amb} = 25\text{ }^{\circ}\text{C}$, and maximum loading.

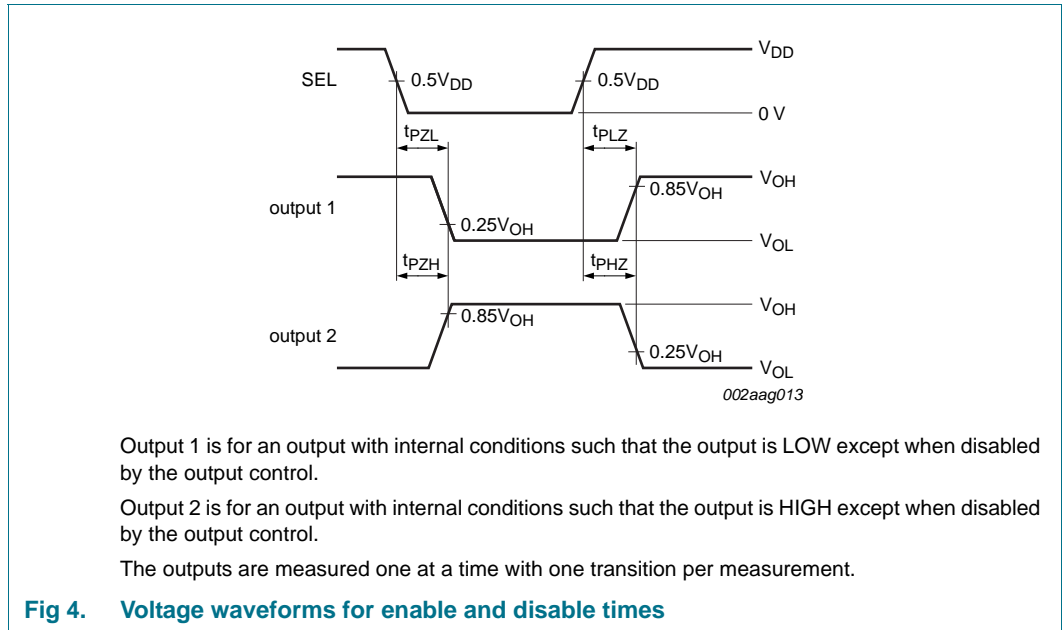

13. Test information

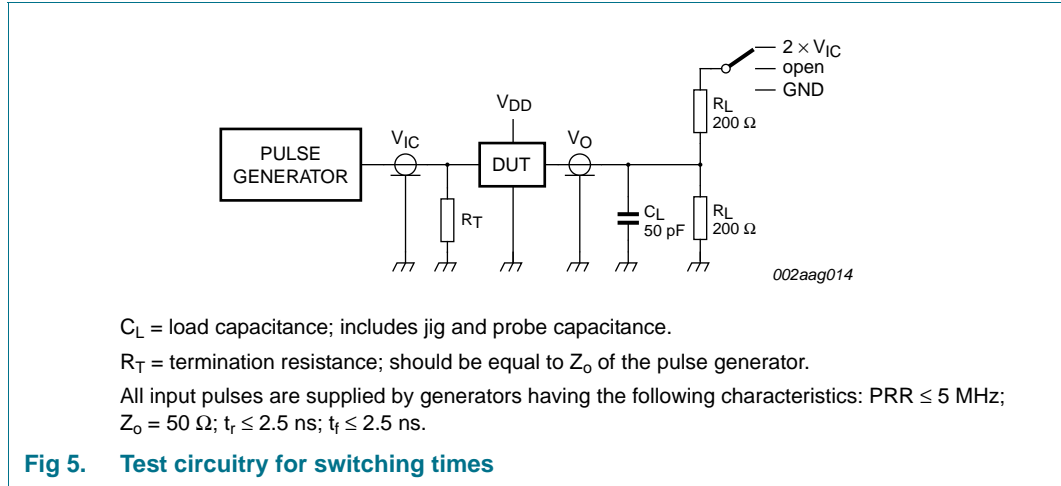

Fig 5. Test circuitry for switching times

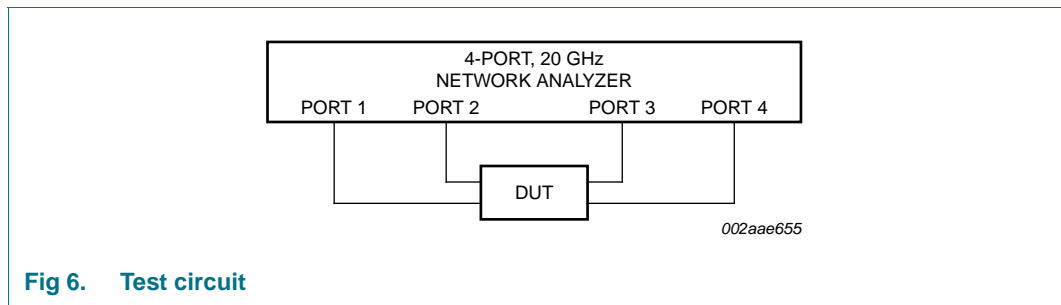

Fig 6. Test circuit

Table 9. Test data

Test	Load		Switch
	C_L	R_L	
t_{PLZ} , t_{PZL} (output on B side)	50 pF	200 Ω	$2 \times V_{IC}$
t_{PHZ} , t_{PZH} (output on B side)	50 pF	200 Ω	GND
t_{PD}	-	200 Ω	open

14. Package outline

HVQFN42: plastic thermal enhanced very thin quad flat package; no leads;
42 terminals; body 3.5 x 9 x 0.85 mm

SOT1144-1

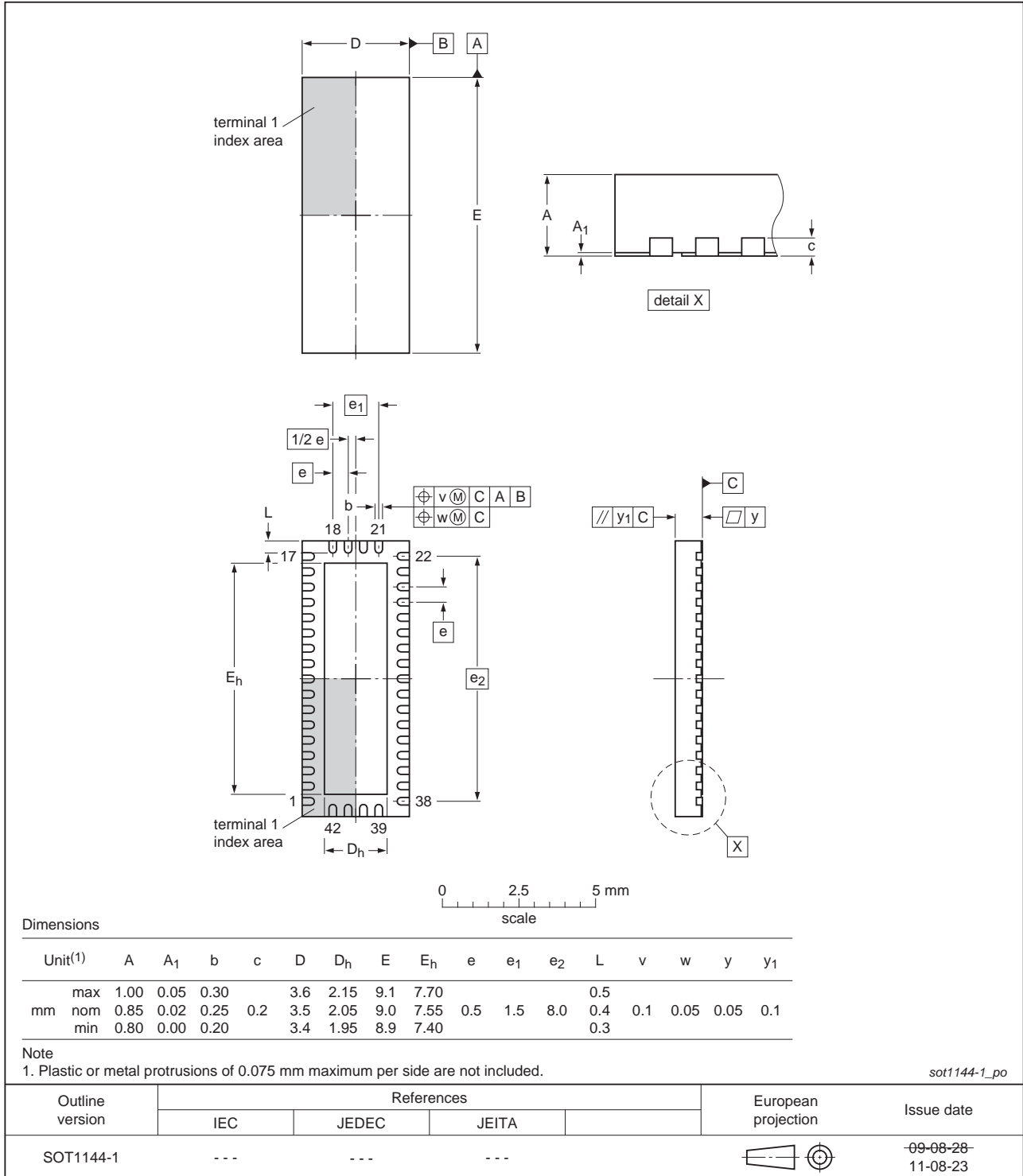

Fig 7. Package outline SOT1144-1 (HVQFN42)

15. Soldering of SMD packages

This text provides a very brief insight into a complex technology. A more in-depth account of soldering ICs can be found in Application Note *AN10365 "Surface mount reflow soldering description"*.

15.1 Introduction to soldering

Soldering is one of the most common methods through which packages are attached to Printed Circuit Boards (PCBs), to form electrical circuits. The soldered joint provides both the mechanical and the electrical connection. There is no single soldering method that is ideal for all IC packages. Wave soldering is often preferred when through-hole and Surface Mount Devices (SMDs) are mixed on one printed wiring board; however, it is not suitable for fine pitch SMDs. Reflow soldering is ideal for the small pitches and high densities that come with increased miniaturization.

15.2 Wave and reflow soldering

Wave soldering is a joining technology in which the joints are made by solder coming from a standing wave of liquid solder. The wave soldering process is suitable for the following:

- Through-hole components
- Leaded or leadless SMDs, which are glued to the surface of the printed circuit board

Not all SMDs can be wave soldered. Packages with solder balls, and some leadless packages which have solder lands underneath the body, cannot be wave soldered. Also, leaded SMDs with leads having a pitch smaller than ~0.6 mm cannot be wave soldered, due to an increased probability of bridging.

The reflow soldering process involves applying solder paste to a board, followed by component placement and exposure to a temperature profile. Leaded packages, packages with solder balls, and leadless packages are all reflow solderable.

Key characteristics in both wave and reflow soldering are:

- Board specifications, including the board finish, solder masks and vias
- Package footprints, including solder thieves and orientation
- The moisture sensitivity level of the packages
- Package placement
- Inspection and repair
- Lead-free soldering versus SnPb soldering

15.3 Wave soldering

Key characteristics in wave soldering are:

- Process issues, such as application of adhesive and flux, clinching of leads, board transport, the solder wave parameters, and the time during which components are exposed to the wave
- Solder bath specifications, including temperature and impurities

15.4 Reflow soldering

Key characteristics in reflow soldering are:

- Lead-free versus SnPb soldering; note that a lead-free reflow process usually leads to higher minimum peak temperatures (see [Figure 8](#)) than a SnPb process, thus reducing the process window
- Solder paste printing issues including smearing, release, and adjusting the process window for a mix of large and small components on one board
- Reflow temperature profile; this profile includes preheat, reflow (in which the board is heated to the peak temperature) and cooling down. It is imperative that the peak temperature is high enough for the solder to make reliable solder joints (a solder paste characteristic). In addition, the peak temperature must be low enough that the packages and/or boards are not damaged. The peak temperature of the package depends on package thickness and volume and is classified in accordance with [Table 10](#) and [11](#)

Table 10. SnPb eutectic process (from J-STD-020C)

Package thickness (mm)	Package reflow temperature (°C)	
	Volume (mm ³)	
	< 350	≥ 350
< 2.5	235	220
≥ 2.5	220	220

Table 11. Lead-free process (from J-STD-020C)

Package thickness (mm)	Package reflow temperature (°C)		
	Volume (mm ³)		
	< 350	350 to 2000	> 2000
< 1.6	260	260	260
1.6 to 2.5	260	250	245
> 2.5	250	245	245

Moisture sensitivity precautions, as indicated on the packing, must be respected at all times.

Studies have shown that small packages reach higher temperatures during reflow soldering, see [Figure 8](#).

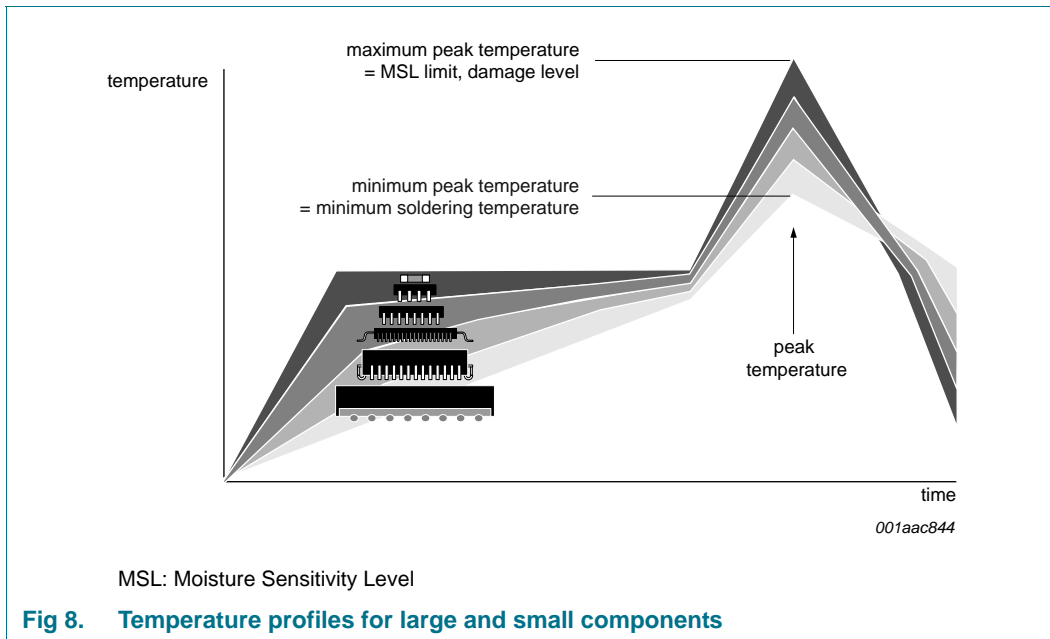

For further information on temperature profiles, refer to Application Note AN10365 “Surface mount reflow soldering description”.

16. Abbreviations

Table 12. Abbreviations

Acronym	Description
CDM	Charged-Device Model
CMOS	Complementary Metal-Oxide Semiconductor
DUT	Device Under Test
ESD	ElectroStatic Discharge
HBM	Human Body Model
I/O	Input/Output
PCI	Peripheral Component Interconnect
PCIe	PCI express
PRR	Pulse Repetition Rate
SATA	Serial Advanced Technology Attachment
USB	Universal Serial Bus

17. Revision history

Table 13. Revision history

Document ID	Release date	Data sheet status	Change notice	Supersedes
CBTL04083A_CBTL04083B v.4	20120625	Product data sheet	-	CBTL04083A_CBTL04083B v.3
Modifications: <ul style="list-style-type: none"> • Section 2 “Features and benefits”: <ul style="list-style-type: none"> – sixth bullet changed from “-35 dB” to “-29 dB” – ninth bullet changed from “-20 dB” to “-14 dB” • Table 1 “Ordering information”: <ul style="list-style-type: none"> – added (new) Table note [1] – added (new) Table note [2] • Table 2 “Pin description”, last table row: GND “Type” changed from “power” to “ground” • Table 8 “Dynamic characteristics”: <ul style="list-style-type: none"> – DDNEXT (condition “f = 4 GHz”) typical value changed from “-35 dB” to “-29 dB” – DDRL (condition “f = 4 GHz”) typical value changed from “-20 dB” to “-14 dB” – DDRL (condition “f = 100 MHz”) typical value changed from “-25 dB” to “-24 dB” 				
CBTL04083A_CBTL04083B v.3	20110824	Product data sheet	-	CBTL04083A_CBTL04083B v.2
CBTL04083A_CBTL04083B v.2	20110524	Product data sheet	-	CBTL04083A_CBTL04083B v.1
CBTL04083A_CBTL04083B v.1	20110228	Product data sheet	-	-

18. Legal information

18.1 Data sheet status

Document status ^{[1][2]}	Product status ^[3]	Definition
Objective [short] data sheet	Development	This document contains data from the objective specification for product development.
Preliminary [short] data sheet	Qualification	This document contains data from the preliminary specification.
Product [short] data sheet	Production	This document contains the product specification.

[1] Please consult the most recently issued document before initiating or completing a design.

[2] The term 'short data sheet' is explained in section "Definitions".

[3] The product status of device(s) described in this document may have changed since this document was published and may differ in case of multiple devices. The latest product status information is available on the Internet at URL <http://www.nxp.com>.

18.2 Definitions

Draft — The document is a draft version only. The content is still under internal review and subject to formal approval, which may result in modifications or additions. NXP Semiconductors does not give any representations or warranties as to the accuracy or completeness of information included herein and shall have no liability for the consequences of use of such information.

Short data sheet — A short data sheet is an extract from a full data sheet with the same product type number(s) and title. A short data sheet is intended for quick reference only and should not be relied upon to contain detailed and full information. For detailed and full information see the relevant full data sheet, which is available on request via the local NXP Semiconductors sales office. In case of any inconsistency or conflict with the short data sheet, the full data sheet shall prevail.

Product specification — The information and data provided in a Product data sheet shall define the specification of the product as agreed between NXP Semiconductors and its customer, unless NXP Semiconductors and customer have explicitly agreed otherwise in writing. In no event however, shall an agreement be valid in which the NXP Semiconductors product is deemed to offer functions and qualities beyond those described in the Product data sheet.

18.3 Disclaimers

Limited warranty and liability — Information in this document is believed to be accurate and reliable. However, NXP Semiconductors does not give any representations or warranties, expressed or implied, as to the accuracy or completeness of such information and shall have no liability for the consequences of use of such information. NXP Semiconductors takes no responsibility for the content in this document if provided by an information source outside of NXP Semiconductors.

In no event shall NXP Semiconductors be liable for any indirect, incidental, punitive, special or consequential damages (including - without limitation - lost profits, lost savings, business interruption, costs related to the removal or replacement of any products or rework charges) whether or not such damages are based on tort (including negligence), warranty, breach of contract or any other legal theory.

Notwithstanding any damages that customer might incur for any reason whatsoever, NXP Semiconductors' aggregate and cumulative liability towards customer for the products described herein shall be limited in accordance with the *Terms and conditions of commercial sale* of NXP Semiconductors.

Right to make changes — NXP Semiconductors reserves the right to make changes to information published in this document, including without limitation specifications and product descriptions, at any time and without notice. This document supersedes and replaces all information supplied prior to the publication hereof.

Suitability for use — NXP Semiconductors products are not designed, authorized or warranted to be suitable for use in life support, life-critical or safety-critical systems or equipment, nor in applications where failure or malfunction of an NXP Semiconductors product can reasonably be expected to result in personal injury, death or severe property or environmental damage. NXP Semiconductors and its suppliers accept no liability for inclusion and/or use of NXP Semiconductors products in such equipment or applications and therefore such inclusion and/or use is at the customer's own risk.

Applications — Applications that are described herein for any of these products are for illustrative purposes only. NXP Semiconductors makes no representation or warranty that such applications will be suitable for the specified use without further testing or modification.

Customers are responsible for the design and operation of their applications and products using NXP Semiconductors products, and NXP Semiconductors accepts no liability for any assistance with applications or customer product design. It is customer's sole responsibility to determine whether the NXP Semiconductors product is suitable and fit for the customer's applications and products planned, as well as for the planned application and use of customer's third party customer(s). Customers should provide appropriate design and operating safeguards to minimize the risks associated with their applications and products.

NXP Semiconductors does not accept any liability related to any default, damage, costs or problem which is based on any weakness or default in the customer's applications or products, or the application or use by customer's third party customer(s). Customer is responsible for doing all necessary testing for the customer's applications and products using NXP Semiconductors products in order to avoid a default of the applications and the products or of the application or use by customer's third party customer(s). NXP does not accept any liability in this respect.

Limiting values — Stress above one or more limiting values (as defined in the Absolute Maximum Ratings System of IEC 60134) will cause permanent damage to the device. Limiting values are stress ratings only and (proper) operation of the device at these or any other conditions above those given in the Recommended operating conditions section (if present) or the Characteristics sections of this document is not warranted. Constant or repeated exposure to limiting values will permanently and irreversibly affect the quality and reliability of the device.

Terms and conditions of commercial sale — NXP Semiconductors products are sold subject to the general terms and conditions of commercial sale, as published at <http://www.nxp.com/profile/terms>, unless otherwise agreed in a valid written individual agreement. In case an individual agreement is concluded only the terms and conditions of the respective agreement shall apply. NXP Semiconductors hereby expressly objects to applying the customer's general terms and conditions with regard to the purchase of NXP Semiconductors products by customer.

No offer to sell or license — Nothing in this document may be interpreted or construed as an offer to sell products that is open for acceptance or the grant, conveyance or implication of any license under any copyrights, patents or other industrial or intellectual property rights.

Export control — This document as well as the item(s) described herein may be subject to export control regulations. Export might require a prior authorization from competent authorities.

Non-automotive qualified products — Unless this data sheet expressly states that this specific NXP Semiconductors product is automotive qualified, the product is not suitable for automotive use. It is neither qualified nor tested in accordance with automotive testing or application requirements. NXP Semiconductors accepts no liability for inclusion and/or use of non-automotive qualified products in automotive equipment or applications.

In the event that customer uses the product for design-in and use in automotive applications to automotive specifications and standards, customer (a) shall use the product without NXP Semiconductors' warranty of the product for such automotive applications, use and specifications, and (b) whenever customer uses the product for automotive applications beyond

NXP Semiconductors' specifications such use shall be solely at customer's own risk, and (c) customer fully indemnifies NXP Semiconductors for any liability, damages or failed product claims resulting from customer design and use of the product for automotive applications beyond NXP Semiconductors' standard warranty and NXP Semiconductors' product specifications.

Translations — A non-English (translated) version of a document is for reference only. The English version shall prevail in case of any discrepancy between the translated and English versions.

18.4 Trademarks

Notice: All referenced brands, product names, service names and trademarks are the property of their respective owners.

19. Contact information

For more information, please visit: <http://www.nxp.com>

For sales office addresses, please send an email to: salesaddresses@nxp.com

20. Contents

1	General description	1
2	Features and benefits	1
3	Applications	2
4	Ordering information	2
5	Functional diagram	3
6	Pinning information	4
6.1	Pinning	4
6.2	Pin description	4
7	Functional description	6
7.1	Function selection	6
7.2	Shutdown function	6
8	Application design-in information	7
9	Limiting values	8
10	Recommended operating conditions	8
11	Static characteristics	8
12	Dynamic characteristics	9
13	Test information	11
14	Package outline	12
15	Soldering of SMD packages	13
15.1	Introduction to soldering	13
15.2	Wave and reflow soldering	13
15.3	Wave soldering	13
15.4	Reflow soldering	14
16	Abbreviations	15
17	Revision history	16
18	Legal information	17
18.1	Data sheet status	17
18.2	Definitions	17
18.3	Disclaimers	17
18.4	Trademarks	18
19	Contact information	18
20	Contents	19

Please be aware that important notices concerning this document and the product(s) described herein, have been included in section 'Legal information'.

© NXP B.V. 2012.

All rights reserved.

For more information, please visit: <http://www.nxp.com>

For sales office addresses, please send an email to: salesaddresses@nxp.com

Date of release: 25 June 2012

Document identifier: CBTL04083A_CBTL04083B



Компания «ЭлектроПласт» предлагает заключение долгосрочных отношений при поставках импортных электронных компонентов на взаимовыгодных условиях!

Наши преимущества:

- Оперативные поставки широкого спектра электронных компонентов отечественного и импортного производства напрямую от производителей и с крупнейших мировых складов;
- Поставка более 17-ти миллионов наименований электронных компонентов;
- Поставка сложных, дефицитных, либо снятых с производства позиций;
- Оперативные сроки поставки под заказ (от 5 рабочих дней);
- Экспресс доставка в любую точку России;
- Техническая поддержка проекта, помощь в подборе аналогов, поставка прототипов;
- Система менеджмента качества сертифицирована по Международному стандарту ISO 9001;
- Лицензия ФСБ на осуществление работ с использованием сведений, составляющих государственную тайну;
- Поставка специализированных компонентов (Xilinx, Altera, Analog Devices, Intersil, Interpoint, Microsemi, Aeroflex, Peregrine, Syfer, Eurofarad, Texas Instrument, Miteq, Cobham, E2V, MA-COM, Hittite, Mini-Circuits, General Dynamics и др.);

Помимо этого, одним из направлений компании «ЭлектроПласт» является направление «Источники питания». Мы предлагаем Вам помощь Конструкторского отдела:

- Подбор оптимального решения, техническое обоснование при выборе компонента;
- Подбор аналогов;
- Консультации по применению компонента;
- Поставка образцов и прототипов;
- Техническая поддержка проекта;
- Защита от снятия компонента с производства.



Как с нами связаться

Телефон: 8 (812) 309 58 32 (многоканальный)

Факс: 8 (812) 320-02-42

Электронная почта: org@eplast1.ru

Адрес: 198099, г. Санкт-Петербург, ул. Калинина, дом 2, корпус 4, литера А.