

# ALUMINUM ELECTROLYTIC CAPACITORS

**NU** Screw Terminal Type, 105°C  
High Voltage, Smaller Sized.  
series

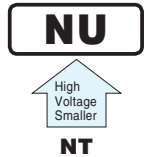

- Suited for use in industrial power supplies for inverter circuitry, etc.
- Rated voltage range up to DC525V.
- Load life of 5000 hours application of ripple current at 105°C.
- High voltage / Smaller sized than NT series.
- Coped with loading of high speed charge-discharge.
- Suited for high frequency regenerative voltage for AC servomotor, general inverter.
- Compliant to the RoHS directive (2011/65/EU).



## Specifications

Item	Performance Characteristics	
Category Temperature Range	- 40 to +105°C	
Rated Voltage Range	400 to 525V	
Rated Capacitance Range	680 to 18000µF	
Capacitance Tolerance	±20% (120Hz, 20°C)	
Leakage Current	After 5 minutes' application of rated voltage, leakage current is not more than $3\sqrt{CV}$ (µA) or 5 mA, whichever is smaller. (at 20°C) [C : Rated Capacitance(µF), V : Voltage (V)]	
Tangent of loss angle (tan δ)	0.2MAX. (120Hz at 20°C)	
Stability at Low Temperature	Rated voltage(V)	400 to 525
	Impedance ratio ZT/Z20(MAX.)	Z - 40°C / Z +20°C 8
Measurement frequency : 120Hz		
Insulation Resistance	The insulation resistance shall be more than 100MΩ at DC 500V application between terminal and bracket.	
Voltage proof	There is no abnormality during AC 2500V 1 minute's application between terminal and bracket.	
Endurance	The specifications listed at right shall be met when the capacitors are restored to 20°C after D.C. bias plus rated ripple current is applied for 5000 hours at 105°C, the peak voltage shall not exceed the rated voltage.	
	Capacitance change	Within ±20% of the initial capacitance value
	tan δ	200% or less than the initial specified value
Shelf Life	After storing the capacitors under no load at 105°C for 1000 hours and then performing voltage treatment based on JIS C 5101-4 clause 4.1 at 20°C, they shall meet the requirements listed at right.	
	Capacitance change	Within ±20% of the initial capacitance value
	tan δ	200% or less than the initial specified value
Endurance of charge - discharge behavior	After an application of charge-discharge voltage for 50million times (charge-discharge voltage difference(ΔV) = rated voltage × 0.3, cycle 3Hz) capacitors shall meet the characteristics requirement listed at right.	
	Capacitance change	Within ±20% of the initial capacitance value
	tan δ	200% or less than the initial specified value
Marking	Printed with white color letter on black sleeve	

## Drawing

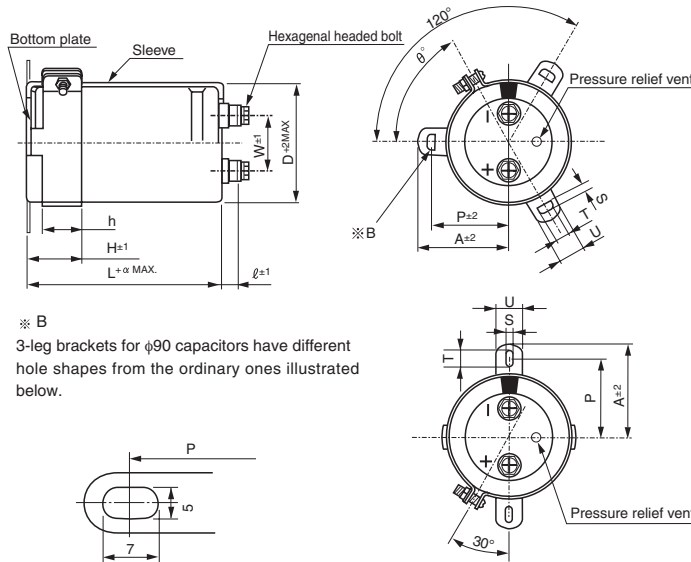

※ B  
3-leg brackets for φ90 capacitors have different hole shapes from the ordinary ones illustrated below.

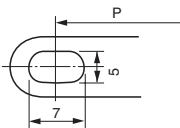

Note) The brackets will be supplied in the separate box.

### Dimension of terminal pitch (W) and length (ℓ) and Nominal dia. of bolt (mm)

φD	W	ℓ	α	Nominal dia. of bolt
51	22.0	6	3	M5
63.5	28.6	6	3	M5
76.2	31.8	6	3	M5
90	31.8	6	3	M5

About product of stud bolt  
 • Nylon nut and nylon washer attachment become the standard specifications. (cf. P.328)  
 • It is not attached to the bracket.  
 • Field 13 and 14 become blank in Type number system.

## Type numbering system (Example : 500V 4700µF)

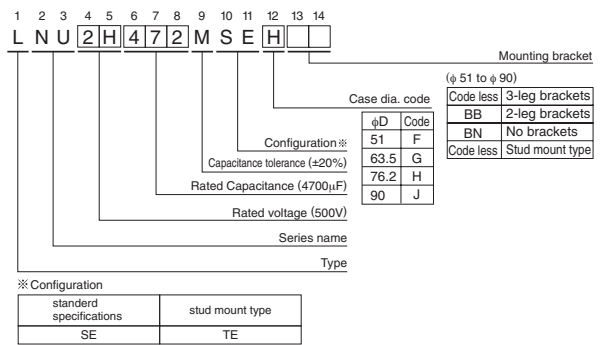

Please refer to page 328 for schematic of dimensions.  
 ※ Please contact to us if PVC less products are required.

## Dimensions of mounting bracket (mm)

Leg shape	Symbol	3-Leg				2-Leg			
		51	63.5	76.2	90	51	63.5	76.2	90
P		32.5	38.1	44.5	50.8	33.2	40.5	46.5	53
A		38.5	43	49.2	58.5	40	46.5	53	59
T		7.5	8.0	7.0	8.0	6.0	7.0	6.0	6.0
S		5.0	5.0	5.0	5.0	4.5	4.5	4.5	4.5
U		12	14	14	18	14	14	14	14
θ°		60	60	60	60	30	30	30	30
H		20	25	30	35	25	35	35	35
h		15	20	24	25	15	20	20	20

• Dimension table in next page.

## NU series

### ■ Dimensions

400V (2G)					
Cap. (μF)	Size φD × L(mm)	Rated ripple (Arms)	tan δ	Leakage Current (mA)	Code
2700	63.5 × 80	11.9	0.20	3.12	LNU2G272MSEG
3300	63.5 × 95	13.6	0.20	3.45	LNU2G332MSEG
	76.2 × 75	13.1	0.20	3.45	LNU2G332MSEH
3900	63.5 × 100	14.6	0.20	3.75	LNU2G392MSEG
	76.2 × 85	14.3	0.20	3.75	LNU2G392MSEH
4700	63.5 × 120	16.1	0.20	4.11	LNU2G472MSEG
	76.2 × 95	15.8	0.20	4.11	LNU2G472MSEH
5600	63.5 × 135	17.7	0.20	4.49	LNU2G562MSEG
	76.2 × 105	17.1	0.20	4.49	LNU2G562MSEH
6800	76.2 × 125	19.5	0.20	4.95	LNU2G682MSEH
	90 × 105	18.8	0.20	4.95	LNU2G682MSEJ
8200	76.2 × 170	24.2	0.20	5.00	LNU2G822MSEH
	90 × 125	23.1	0.20	5.00	LNU2G822MSEJ
10000	90 × 145	25.9	0.20	5.00	LNU2G103MSEJ
12000	90 × 165	30.1	0.20	5.00	LNU2G123MSEJ
15000	90 × 195	33.5	0.20	5.00	LNU2G153MSEJ
18000	90 × 235	38.0	0.20	5.00	LNU2G183MSEJ

450V (2W)					
Cap. (μF)	Size φD × L(mm)	Rated ripple (Arms)	tan δ	Leakage Current (mA)	Code
2700	63.5 × 100	13.1	0.20	3.31	LNU2W272MSEG
3300	63.5 × 120	15.0	0.20	3.66	LNU2W332MSEG
	76.2 × 95	14.4	0.20	3.66	LNU2W332MSEH
3900	63.5 × 135	16.3	0.20	3.97	LNU2W392MSEG
	76.2 × 105	15.4	0.20	3.97	LNU2W392MSEH
4700	63.5 × 165	18.5	0.20	4.36	LNU2W472MSEG
	76.2 × 130	17.9	0.20	4.36	LNU2W472MSEH
5600	76.2 × 150	20.5	0.20	4.76	LNU2W562MSEH
	90 × 105	19.6	0.20	4.76	LNU2W562MSEJ
6800	76.2 × 170	23.4	0.20	5.00	LNU2W682MSEH
	90 × 125	22.5	0.20	5.00	LNU2W682MSEJ
8200	76.2 × 195	25.7	0.20	5.00	LNU2W822MSEH
	90 × 145	24.7	0.20	5.00	LNU2W822MSEJ
10000	90 × 165	27.3	0.20	5.00	LNU2W103MSEJ
12000	90 × 195	29.9	0.20	5.00	LNU2W123MSEJ
15000	90 × 235	34.5	0.20	5.00	LNU2W153MSEJ

500V (2H)					
Cap. (μF)	Size φD × L(mm)	Rated ripple (Arms)	tan δ	Leakage Current (mA)	Code
680	51 × 75	4.0	0.20	1.75	LNUN2H681MSEF
1000	51 × 90	5.0	0.20	2.12	LNUN2H102MSEF
1200	51 × 115	5.7	0.20	2.32	LNUN2H122MSEF
	63.5 × 80	5.7	0.20	2.32	LNUN2H122MSEG
1500	51 × 135	6.6	0.20	2.60	LNUN2H152MSEF
	63.5 × 90	6.6	0.20	2.60	LNUN2H152MSEG
1800	63.5 × 100	7.4	0.20	2.85	LNUN2H182MSEG
	76.2 × 70	7.4	0.20	2.85	LNUN2H182MSEH
2200	63.5 × 120	8.5	0.20	3.15	LNUN2H222MSEG
	76.2 × 95	8.5	0.20	3.15	LNUN2H222MSEH
2700	63.5 × 135	9.6	0.20	3.49	LNUN2H272MSEG
	76.2 × 105	9.6	0.20	3.49	LNUN2H272MSEH
3300	63.5 × 165	10.9	0.20	3.85	LNUN2H332MSEG
	76.2 × 130	10.9	0.20	3.85	LNUN2H332MSEH
3900	76.2 × 145	12.4	0.20	4.19	LNUN2H392MSEH
	90 × 105	12.4	0.20	4.19	LNUN2H392MSEJ
4700	76.2 × 165	13.9	0.20	4.60	LNUN2H472MSEH
	90 × 125	13.9	0.20	4.60	LNUN2H472MSEJ
5600	90 × 145	15.8	0.20	5.00	LNUN2H562MSEJ
6800	90 × 165	18.5	0.20	5.00	LNUN2H682MSEJ
8200	90 × 205	20.2	0.20	5.00	LNUN2H822MSEJ

525V (N7)					
Cap. (μF)	Size φD × L(mm)	Rated ripple (Arms)	tan δ	Leakage Current (mA)	Code
680	51 × 85	4.4	0.20	1.75	LNUN7681MSEF
1000	51 × 95	5.4	0.20	2.12	LNUN7102MSEF
1500	63.5 × 95	7.2	0.20	2.60	LNUN7152MSEG
1800	63.5 × 105	8.0	0.20	2.85	LNUN7182MSEG
2200	63.5 × 135	9.2	0.20	3.15	LNUN7222MSEG
	76.2 × 100	9.2	0.20	3.15	LNUN7222MSEH
2700	76.2 × 115	10.6	0.20	3.49	LNUN7272MSEH
3300	76.2 × 140	12.1	0.20	3.85	LNUN7332MSEH
4700	76.2 × 185	15.2	0.20	4.60	LNUN7472MSEH
	90 × 135	15.2	0.20	4.60	LNUN7472MSEJ
5600	90 × 155	17.5	0.20	5.00	LNUN7562MSEJ

Rated ripple current (Arms) at 105°C 120Hz

### ● Frequency coefficient of rated ripple current

Frequency (Hz)	50	60	120	360	1k	10k or more
Coefficient	0.80	0.82	1.00	1.20	1.30	1.40



Компания «ЭлектроПласт» предлагает заключение долгосрочных отношений при поставках импортных электронных компонентов на взаимовыгодных условиях!

Наши преимущества:

- Оперативные поставки широкого спектра электронных компонентов отечественного и импортного производства напрямую от производителей и с крупнейших мировых складов;
- Поставка более 17-ти миллионов наименований электронных компонентов;
- Поставка сложных, дефицитных, либо снятых с производства позиций;
- Оперативные сроки поставки под заказ (от 5 рабочих дней);
- Экспресс доставка в любую точку России;
- Техническая поддержка проекта, помощь в подборе аналогов, поставка прототипов;
- Система менеджмента качества сертифицирована по Международному стандарту ISO 9001;
- Лицензия ФСБ на осуществление работ с использованием сведений, составляющих государственную тайну;
- Поставка специализированных компонентов (Xilinx, Altera, Analog Devices, Intersil, Interpoint, Microsemi, Aeroflex, Peregrine, Syfer, Eurofarad, Texas Instrument, Miteq, Cobham, E2V, MA-COM, Hittite, Mini-Circuits, General Dynamics и др.);

Помимо этого, одним из направлений компании «ЭлектроПласт» является направление «Источники питания». Мы предлагаем Вам помощь Конструкторского отдела:

- Подбор оптимального решения, техническое обоснование при выборе компонента;
- Подбор аналогов;
- Консультации по применению компонента;
- Поставка образцов и прототипов;
- Техническая поддержка проекта;
- Защита от снятия компонента с производства.



#### Как с нами связаться

**Телефон:** 8 (812) 309 58 32 (многоканальный)

**Факс:** 8 (812) 320-02-42

**Электронная почта:** [org@eplast1.ru](mailto:org@eplast1.ru)

**Адрес:** 198099, г. Санкт-Петербург, ул. Калинина, дом 2, корпус 4, литера А.