



SANYO Semiconductors

DATA SHEET

An ON Semiconductor Company

LA0151CS

Monolithic Linear IC
For Ultra-small illumination Sensor
Photo IC

Overview

The LA0151CS is a photo IC for ultra-small illumination sensor. It enables to be mounted on a very small limited space such as on the mobile phones which is becoming small and thinner and on other mobile applications.

Functions

- Linear current output
- Low gain mode function [low gain : -35dB]

Specifications

Absolute Maximum Ratings at $T_a = 25^\circ\text{C}$

Parameter	Symbol	Conditions	Ratings	Unit
Maximum supply voltage	V_{CC}		6	V
Operating temperature	T_{opr}		-30 to +85	$^\circ\text{C}$
Storage temperature	T_{stg}		-40 to +100	$^\circ\text{C}$

Recommended operating conditions and operating voltage range at $T_a = 25^\circ\text{C}$

Parameter	Symbol	Conditions	Ratings			Unit
			min	typ	max	
Recommended supply voltage	V_{CC}		2.2	3.3	5.5	V
SW pin low voltage	V_l	Normal gain mode	0		0.4	V
SW pin high voltage	V_h	Low gain mode	2.1			V

■ Any and all SANYO Semiconductor Co.,Ltd. products described or contained herein are, with regard to "standard application", intended for the use as general electronics equipment (home appliances, AV equipment, communication device, office equipment, industrial equipment etc.). The products mentioned herein shall not be intended for use for any "special application" (medical equipment whose purpose is to sustain life, aerospace instrument, nuclear control device, burning appliances, transportation machine, traffic signal system, safety equipment etc.) that shall require extremely high level of reliability and can directly threaten human lives in case of failure or malfunction of the product or may cause harm to human bodies, nor shall they grant any guarantee thereof. If you should intend to use our products for applications outside the standard applications of our customer who is considering such use and/or outside the scope of our intended standard applications, please consult with us prior to the intended use. If there is no consultation or inquiry before the intended use, our customer shall be solely responsible for the use.

■ Specifications of any and all SANYO Semiconductor Co.,Ltd. products described or contained herein stipulate the performance, characteristics, and functions of the described products in the independent state, and are not guarantees of the performance, characteristics, and functions of the described products as mounted in the customer's products or equipment. To verify symptoms and states that cannot be evaluated in an independent device, the customer should always evaluate and test devices mounted in the customer's products or equipment.

SANYO Semiconductor Co., Ltd.

TOKYO OFFICE Tokyo Bldg., 1-10, 1 Chome, Ueno, Taito-ku, TOKYO, 110-8534 JAPAN

LA0151CS

Electrical and optical characteristics at $T_a = 25^\circ\text{C}$, $V_{CC} = 3.3\text{V}$

Parameter	Symbol	Conditions	Ratings			Unit
			min	typ	max	
Current dissipation (1) *1, *3	I_{CC}	$E_v = 1000 \text{ lx}$, $R_L = 5\text{k}\Omega$, N mode	90	150	210	μA
Current dissipation (2) *1, *3	I_{CC}	$E_v = 1000 \text{ lx}$, $R_L = 5\text{k}\Omega$, L mode	42	70	98	μA
Output current (1) *1, *3	I_{O1}	$E_v = 100 \text{ lx}$, N mode	6	8	10	μA
Output current (2) *1, *3	I_{O2}	$E_v = 1000 \text{ lx}$, N mode	60	80	100	μA
Output current (3) *1, *3	I_{O3}	$E_v = 100 \text{ lx}$, L mode	0.12	0.16	0.2	μA
Output current (4) *1, *3	I_{O4}	$E_v = 1000 \text{ lx}$, L mode	1.2	1.6	2.0	μA
Dark current	I_{leak}	$E_v = 0 \text{ lx}$, N mode, L mode			0.1	μA
Temperature coefficient *2	I_{tc}	$E_v = 100 \text{ lx}$, N mode, L mode, $T_a = -20 \text{ to } 60^\circ\text{C}$		0.34		$\%/\text{C}$
Rise time (1) *4	T_{r1}	$E_v = 1000 \text{ lx}$, $R_L = 5\text{k}\Omega$, N mode		15	40	μs
Rise time (2) *4	T_{r2}	$E_v = 1000 \text{ lx}$, $R_L = 500\text{k}\Omega$, L mode		20	50	μs
Fall time (1) *4	T_{f1}	$E_v = 1000 \text{ lx}$, $R_L = 5\text{k}\Omega$, N mode		150	500	μs
Fall time (2) *4	T_{f2}	$E_v = 1000 \text{ lx}$, $R_L = 500\text{k}\Omega$, L mode		150	500	μs
Peak sensitivity wave length *2	λ_p			550		nm
Saturation output voltage *5	V_O	$E_v = 1000 \text{ lx}$, $R_L = 150\text{k}\Omega$, N mode	3.0	3.2		V

N mode and L mode stand for the normal gain mode and the low gain mode, respectively.

*1. Measured with the standard light source A. White LED is used instead in the mass production line.

*2. Design guaranteed item

*3. Test circuit for measuring current dissipation and output current

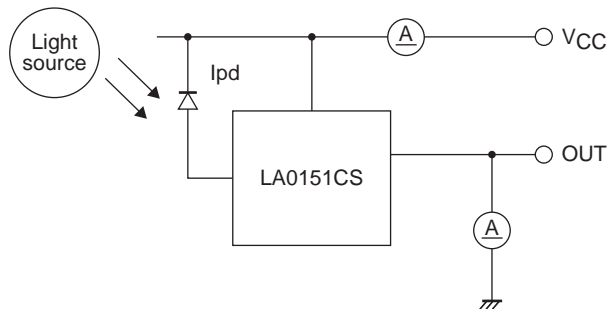

*4. Measuring method of rise time (T_r) and fall time (T_f)

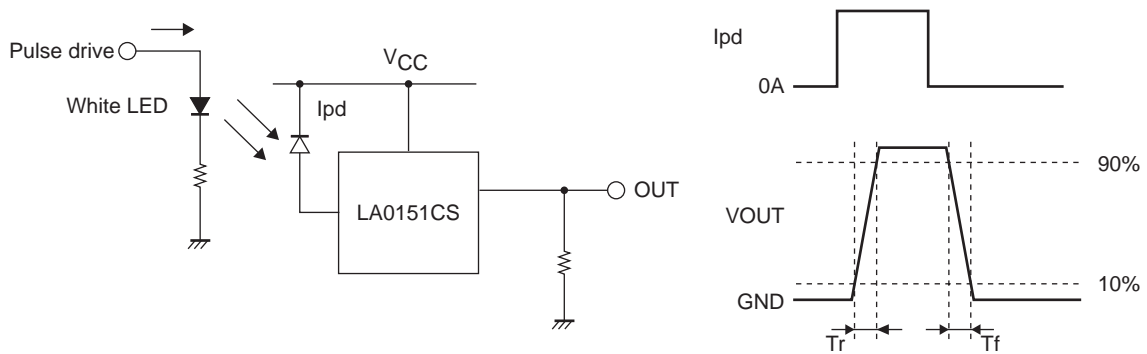

*5. Reference value : min = 2.6V and typ = 2.8V when $V_{CC} = 2.9\text{V}$

Package Dimensions

unit : mm (typ)
3350A

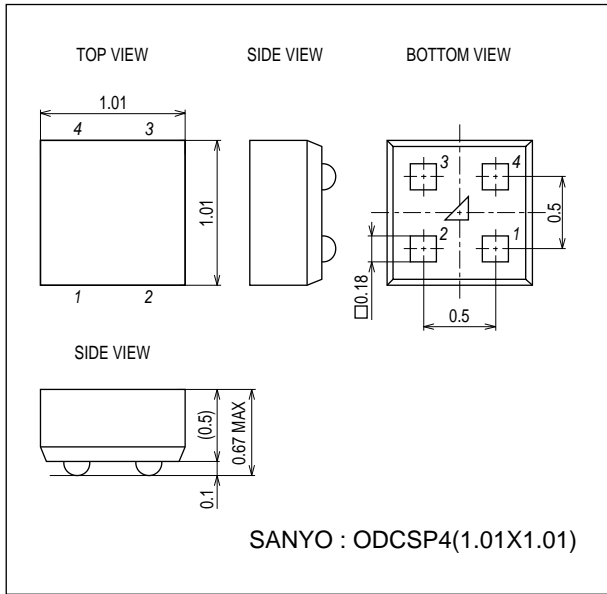

Pad layout

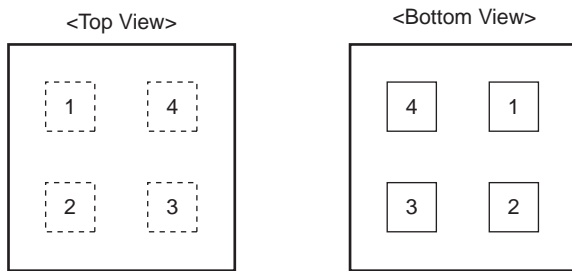

Pin No.	Pin Name	Function
1	VCC	Power supply
2	SW	Switch
3	GND	Ground
4	OUT	Output

Ball pitch : 0.5mm, Ball size : 0.18mm[□]

Pad layout (Photos)

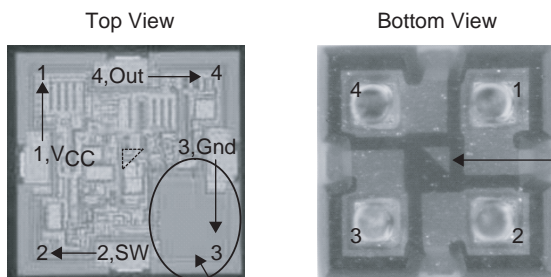

Pin 1 mark
It is located at the center of the bottom of the package.

Photo diode. Only this part looks dark on the product.

* The photo diode is located in pin 3. Be careful not to mistake the pin 1 mark for the photo diode.

LA0151CS

Internal block diagram

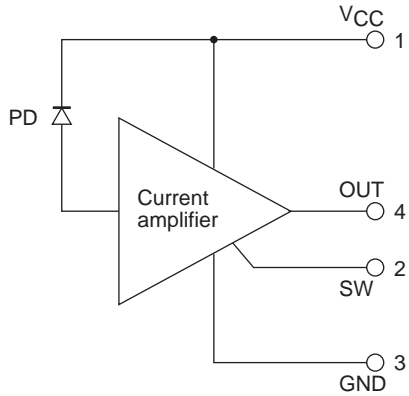

Chip pattern and photo-receiving pattern diagrams

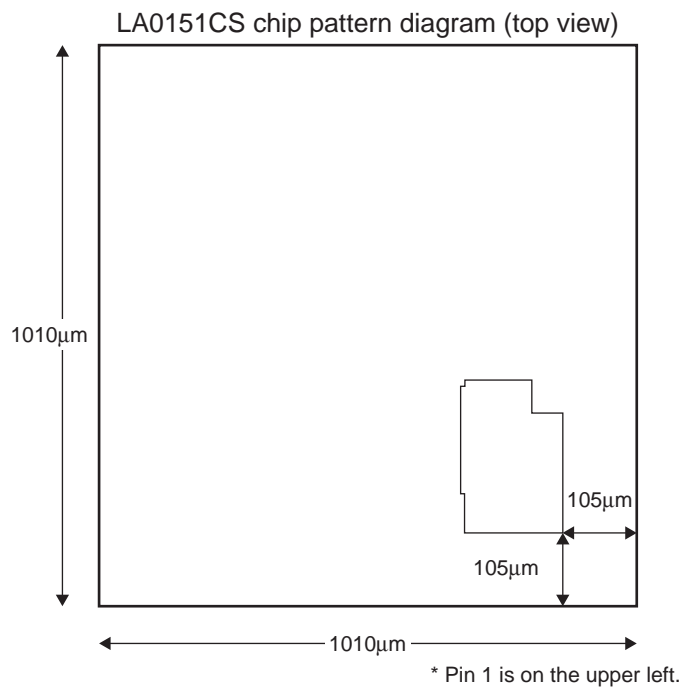

LA0151CS photo-receiving pattern enlarged diagram (effective area)

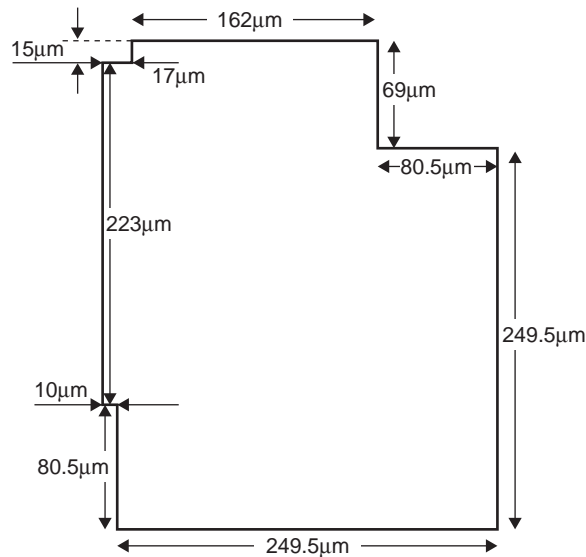

LA0151CS

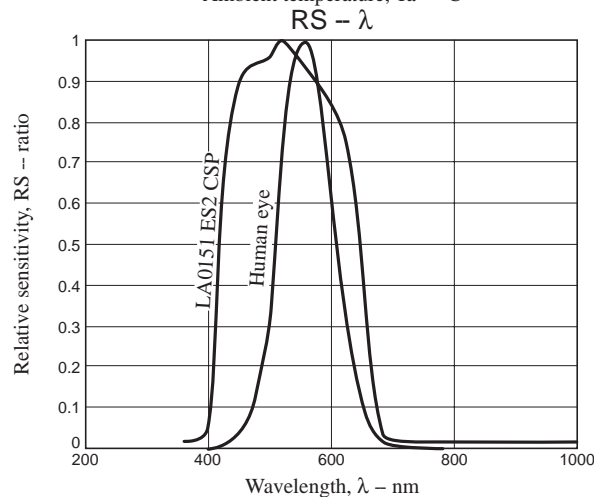
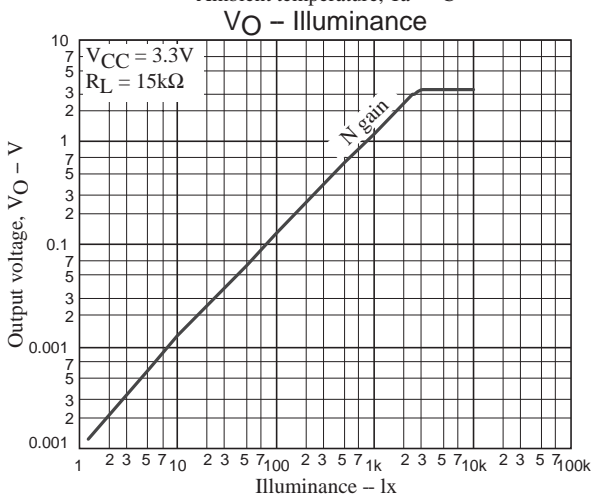
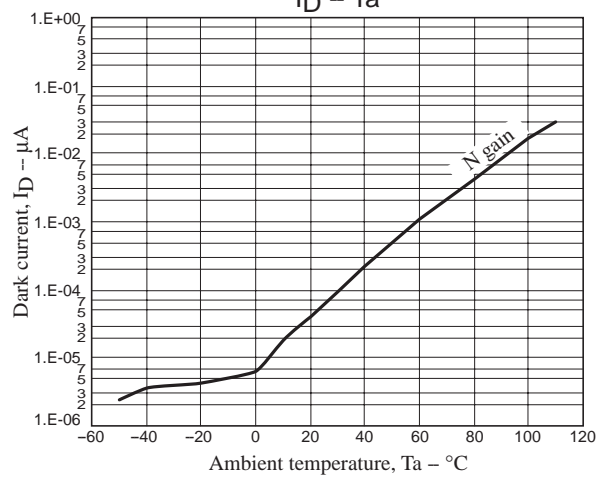
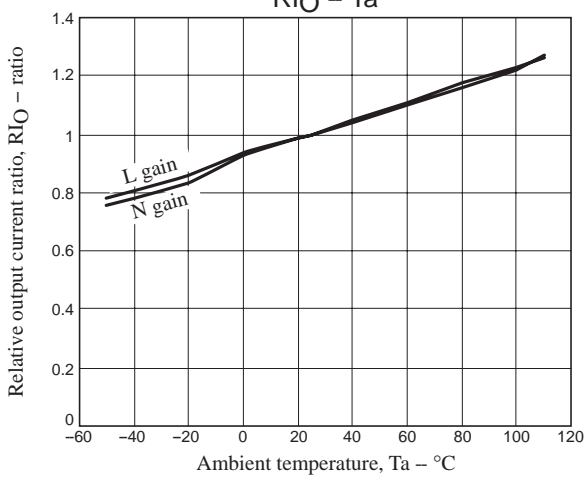
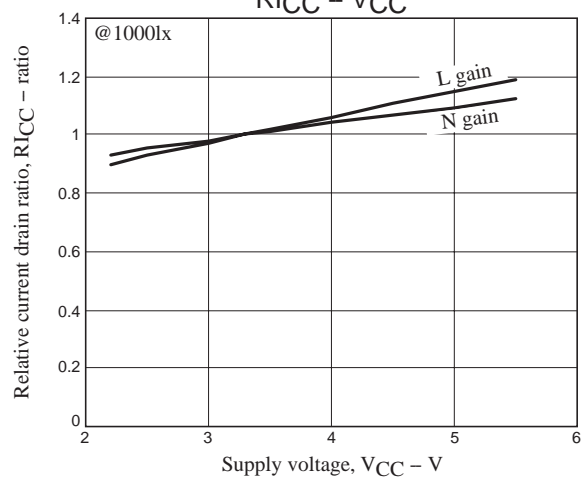
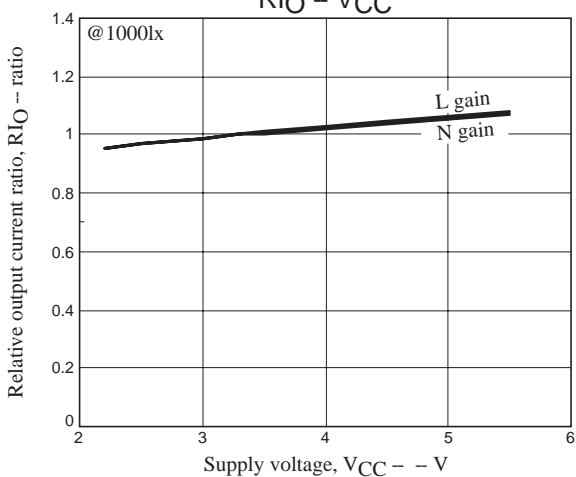
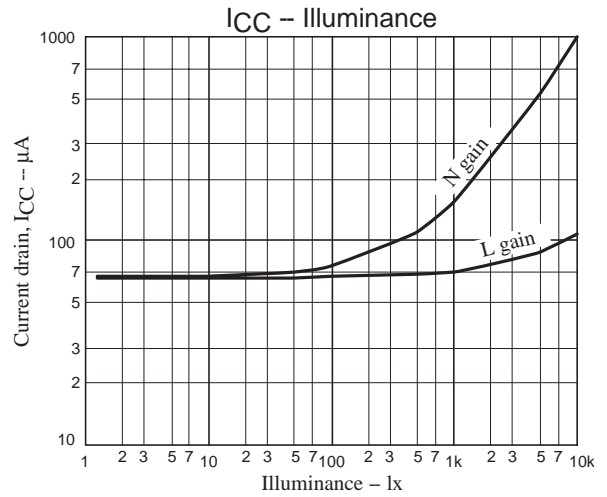
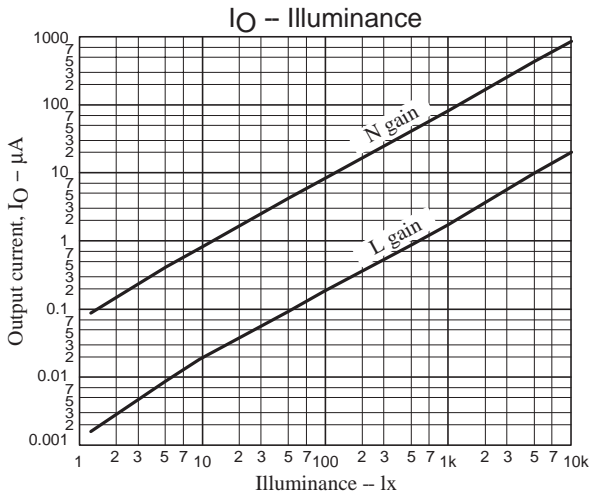

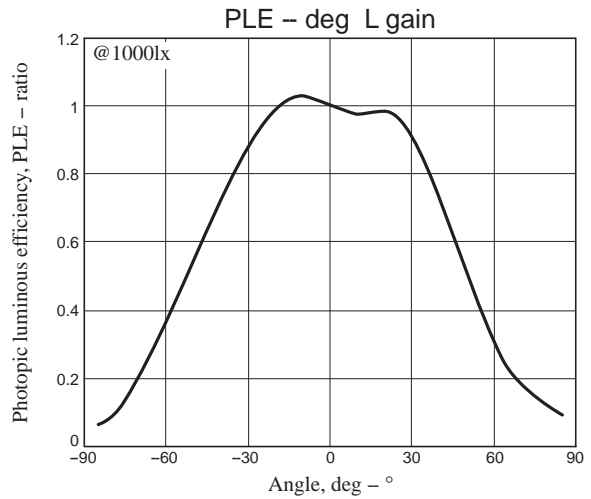
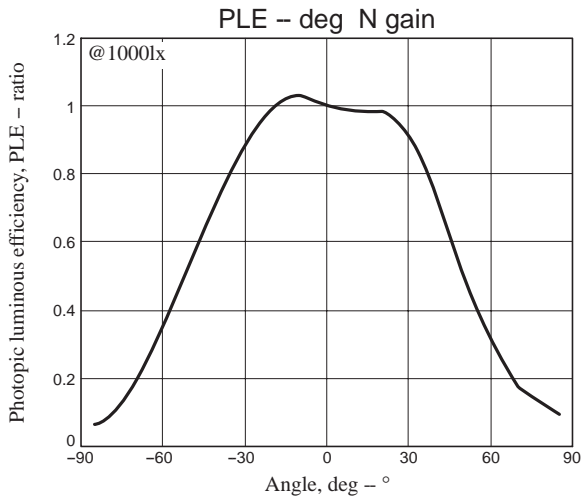

- SANYO Semiconductor Co.,Ltd. assumes no responsibility for equipment failures that result from using products at values that exceed, even momentarily, rated values (such as maximum ratings, operating condition ranges, or other parameters) listed in products specifications of any and all SANYO Semiconductor Co.,Ltd. products described or contained herein.
- SANYO Semiconductor Co.,Ltd. strives to supply high-quality high-reliability products, however, any and all semiconductor products fail or malfunction with some probability. It is possible that these probabilistic failures or malfunction could give rise to accidents or events that could endanger human lives, trouble that could give rise to smoke or fire, or accidents that could cause damage to other property. When designing equipment, adopt safety measures so that these kinds of accidents or events cannot occur. Such measures include but are not limited to protective circuits and error prevention circuits for safe design, redundant design, and structural design.
- In the event that any or all SANYO Semiconductor Co.,Ltd. products described or contained herein are controlled under any of applicable local export control laws and regulations, such products may require the export license from the authorities concerned in accordance with the above law.
- No part of this publication may be reproduced or transmitted in any form or by any means, electronic or mechanical, including photocopying and recording, or any information storage or retrieval system, or otherwise, without the prior written consent of SANYO Semiconductor Co.,Ltd.
- Any and all information described or contained herein are subject to change without notice due to product/technology improvement, etc. When designing equipment, refer to the "Delivery Specification" for the SANYO Semiconductor Co.,Ltd. product that you intend to use.
- Information (including circuit diagrams and circuit parameters) herein is for example only; it is not guaranteed for volume production.
- Upon using the technical information or products described herein, neither warranty nor license shall be granted with regard to intellectual property rights or any other rights of SANYO Semiconductor Co.,Ltd. or any third party. SANYO Semiconductor Co.,Ltd. shall not be liable for any claim or suits with regard to a third party's intellectual property rights which has resulted from the use of the technical information and products mentioned above.

This catalog provides information as of May, 2008. Specifications and information herein are subject to change without notice.



Компания «ЭлектроПласт» предлагает заключение долгосрочных отношений при поставках импортных электронных компонентов на взаимовыгодных условиях!

Наши преимущества:

- Оперативные поставки широкого спектра электронных компонентов отечественного и импортного производства напрямую от производителей и с крупнейших мировых складов;
- Поставка более 17-ти миллионов наименований электронных компонентов;
- Поставка сложных, дефицитных, либо снятых с производства позиций;
- Оперативные сроки поставки под заказ (от 5 рабочих дней);
- Экспресс доставка в любую точку России;
- Техническая поддержка проекта, помощь в подборе аналогов, поставка прототипов;
- Система менеджмента качества сертифицирована по Международному стандарту ISO 9001;
- Лицензия ФСБ на осуществление работ с использованием сведений, составляющих государственную тайну;
- Поставка специализированных компонентов (Xilinx, Altera, Analog Devices, Intersil, Interpoint, Microsemi, Aeroflex, Peregrine, Syfer, Eurofarad, Texas Instrument, Miteq, Cobham, E2V, MA-COM, Hittite, Mini-Circuits, General Dynamics и др.);

Помимо этого, одним из направлений компании «ЭлектроПласт» является направление «Источники питания». Мы предлагаем Вам помощь Конструкторского отдела:

- Подбор оптимального решения, техническое обоснование при выборе компонента;
- Подбор аналогов;
- Консультации по применению компонента;
- Поставка образцов и прототипов;
- Техническая поддержка проекта;
- Защита от снятия компонента с производства.



Как с нами связаться

Телефон: 8 (812) 309 58 32 (многоканальный)

Факс: 8 (812) 320-02-42

Электронная почта: org@eplast1.ru

Адрес: 198099, г. Санкт-Петербург, ул. Калинина, дом 2, корпус 4, литера А.