



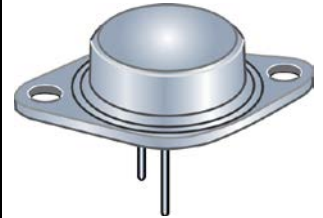
PNP Darlington Power Silicon Transistor

Qualified per MIL-PRF-19500/527

*Qualified Levels:
JAN, JANTX, and
JANTXV*

DESCRIPTION

This high speed PNP transistor is rated at -10 amps and is military qualified up to the JANTXV level. This TO-204AA isolated package features a 180 degree lead orientation.



Important: For the latest information, visit our website <http://www.microsemi.com>.

**TO-204AA (TO-3)
Package**

FEATURES

- JEDEC registered 2N6648 through 2N6650
- JAN, JANTX, and JANTXV qualifications are available per MIL-PRF-19500/527
- RoHS compliant versions available (commercial grade only)

APPLICATIONS / BENEFITS

- Military and other high reliability applications
- High frequency response
- TO-204AA case with isolated terminals

MAXIMUM RATINGS @ T_A = +25 °C unless otherwise noted

Parameters/Test Conditions	Symbol	Value	Unit
Junction and Storage Temperature	T _J and T _{STG}	-65 to +175	°C
Thermal Resistance Junction-to-Case	R _{θJC}	1.76	°C/W
Collector-Emitter Voltage	2N6648	V _{CEO}	-40
	2N6649		-60
	2N6650		-80
Collector-Base Voltage	2N6648	V _{CBO}	-40
	2N6649		-60
	2N6650		-80
Emitter-Base Voltage	V _{EBO}	-5	V
Total Power Dissipation	@ T _A = +25 °C ⁽¹⁾	P _T	5.0
	@ T _C = +25 °C ⁽²⁾		85
Base Current	I _B	-0.25	A
Collector Current	I _C	-10	A

- Notes:**
1. Derate linearly 33.3 mW/°C above T_A > +25 °C.
 2. Derate linearly 567 mW/°C above T_C > +25 °C.

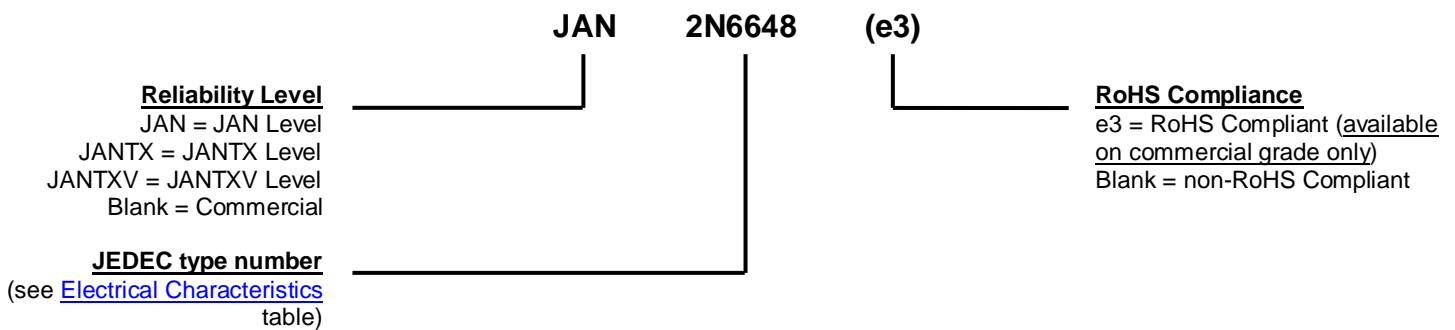
MSC – Lawrence
6 Lake Street,
Lawrence, MA 01841
1-800-446-1158
(978) 620-2600
Fax: (978) 689-0803

MSC – Ireland
Gort Road Business Park,
Ennis, Co. Clare, Ireland
Tel: +353 (0) 65 6840044
Fax: +353 (0) 65 6822298

Website:
www.microsemi.com

MECHANICAL and PACKAGING

- CASE: Industry standard TO-204AA (TO-3), hermetically sealed, 0.040 inch diameter pins
- FINISH: Solder dipped tin-lead over nickel plated alloy 52 or RoHS compliant matte-tin plating. Solderable per MIL-STD-750 method 2026.
- POLARITY: PNP (see [schematic](#))
- MOUNTING HARDWARE: Consult factory for optional insulator and sheet metal screws
- WEIGHT: Approximately 15 grams
- See [package dimensions](#) on last page.

PART NOMENCLATURE

SYMBOLS & DEFINITIONS

Symbol	Definition
I_B	Base current: The value of the dc current into the base terminal.
I_C	Collector current: The value of the dc current into the collector terminal.
I_E	Emitter current: The value of the dc current into the emitter terminal.
T_C	Case temperature: The temperature measured at a specified location on the case of a device.
V_{CB}	Collector-base voltage: The dc voltage between the collector and the base.
V_{CBO}	Collector-base voltage, base open: The voltage between the collector and base terminals when the emitter terminal is open-circuited.
V_{CC}	Collector-supply voltage: The supply voltage applied to a circuit connected to the collector.
V_{CEO}	Collector-emitter voltage, base open: The voltage between the collector and the emitter terminals when the base terminal is open-circuited.
V_{CE}	Collector-emitter voltage: The dc voltage between the collector and the emitter.
V_{EB}	Emitter-base voltage: The dc voltage between the emitter and the base.
V_{EBO}	Emitter-base voltage, collector open: The voltage between the emitter and base terminals with the collector terminal open-circuited.

ELECTRICAL CHARACTERISTICS @ $T_A = +25^\circ\text{C}$ unless otherwise noted

Characteristics	Symbol	Min.	Max.	Unit
-----------------	--------	------	------	------

OFF CHARACTERISTICS

Collector-Emitter Breakdown Voltage $I_C = -200\text{ mA}$	2N6648 2N6649 2N6650	$V_{(BR)CEO}$	-40 -60 -80	V
Collector-Emitter Breakdown Voltage $I_C = -200\text{ mA}, R_{BB} = 100\ \Omega$	2N6648 2N6649 2N6650	$V_{(BR)CER}$	-40 -60 -80	V
Collector-Emitter Cutoff Current $V_{CE} = -40\text{ V}$ $V_{CE} = -60\text{ V}$ $V_{CE} = -80\text{ V}$	2N6648 2N6649 2N6650	I_{CEO}		-1.0 mA
Collector-Emitter Cutoff Current $V_{CE} = -40\text{ V}, V_{BE} = 1.5\text{ V}$ $V_{CE} = -60\text{ V}, V_{BE} = 1.5\text{ V}$ $V_{CE} = -80\text{ V}, V_{BE} = 1.5\text{ V}$	2N6648 2N6649 2N6650	I_{CEX}		10 μA
Emitter-Base Cutoff Current $V_{EB} = 5.0\text{ V}$		I_{EBO}		-10 mA
Collector-Emitter Cutoff Current $V_{CE} = -40\text{ V}$ $V_{CE} = -60\text{ V}$ $V_{CE} = -80\text{ V}$	2N6648 2N6649 2N6650	I_{CBO}		-1.0 mA

ON CHARACTERISTICS

Forward-Current Transfer Ratio $I_C = -1.0\text{ A}, V_{CE} = -3.0\text{ V}$ $I_C = -5\text{ A}, V_{CE} = -3.0\text{ V}$ $I_C = -10\text{ A}, V_{CE} = -3.0\text{ V}$ $I_C = -5\text{ A}, V_{CE} = -3.0\text{ V}, T_A = -65^\circ\text{C}$		h_{FE}	300 1,000 100 200	20,000
Collector-Emitter Saturation Voltage $I_C = -5.0\text{ A}, I_B = -10\text{ mA}$ $I_C = -10\text{ A}, I_B = -0.1\text{ mA}$		$V_{CE(sat)}$		-2.0 -3.0 V
Base-Emitter Voltage Non-saturated $V_{CE} = -3.0\text{ V}, I_C = -5.0\text{ A}$ $V_{CE} = -3.0\text{ V}, I_C = -10\text{ A}$		$V_{BE(on)}$		-2.8 -4.5 V

DYNAMIC CHARACTERISTICS

Magnitude of Common Emitter Small-Signal Short-Circuit Forward Current Transfer Ratio $I_C = -1.0\text{ A}, V_{CE} = -5.0\text{ V}, f = 1.0\text{ MHz}$		$ h_{fe} $	30	400
Output Capacitance $V_{CB} = -10\text{ V}, I_E = 0, 100\text{ kHz} \leq f \leq 1\text{ MHz}$		C_{obo}		300 pF

ELECTRICAL CHARACTERISTICS @ $T_C = 25^\circ\text{C}$ unless otherwise noted. (continued)
SWITCHING CHARACTERISTICS

Turn-On Time $V_{CC} = -30\text{ V}, I_C = -5.0\text{ A}; I_B = -20\text{ mA}$	t_{on}		2.5	μs
Turn-Off Time $V_{CC} = -30\text{ V}, I_C = -5.0\text{ A}; I_{B1} = I_{B2} = -20\text{ mA}$	t_{off}		10	μs

SAFE OPERATING AREA (See [Figures 1 and 2](#) and [MIL-STD-750, Test Method 3053](#))
DC Tests
 $T_C = +25^\circ\text{C}, t = 1\text{ second}, 1\text{ Cycle}$
Test 1
 $V_{CE} = -8.5\text{ V}, I_C = -10\text{ A}$
Test 2
 $V_{CE} = -25\text{ V}, I_C = -3.4\text{ A}$
Test 3
 $V_{CE} = -40\text{ V}, I_C = -0.9\text{ A}$ (2N6648)

 $V_{CE} = -60\text{ V}, I_C = -0.3\text{ A}$ (2N6649)

 $V_{CE} = -80\text{ V}, I_C = -0.14\text{ A}$ (2N6650)

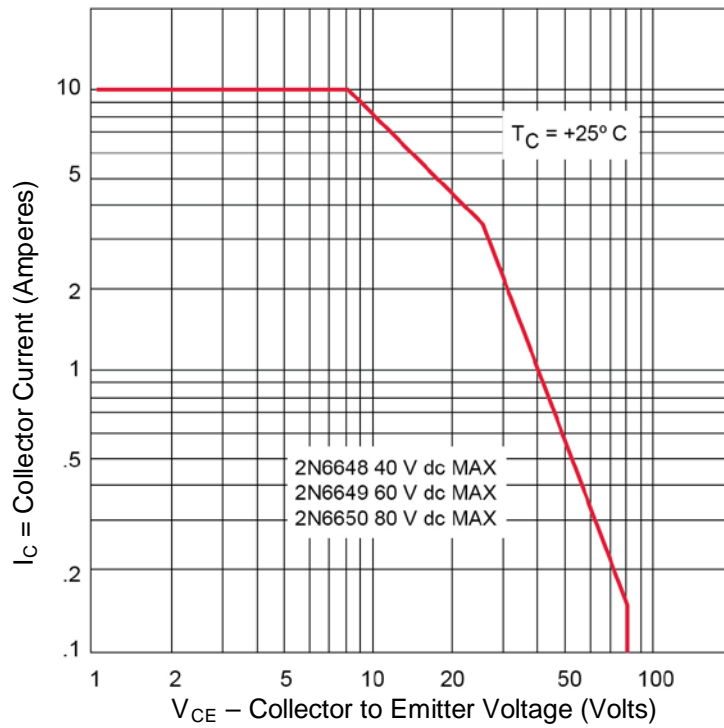
SAFE OPERATING AREA


FIGURE 1
 Maximum Safe Operating Graph (continuous dc)

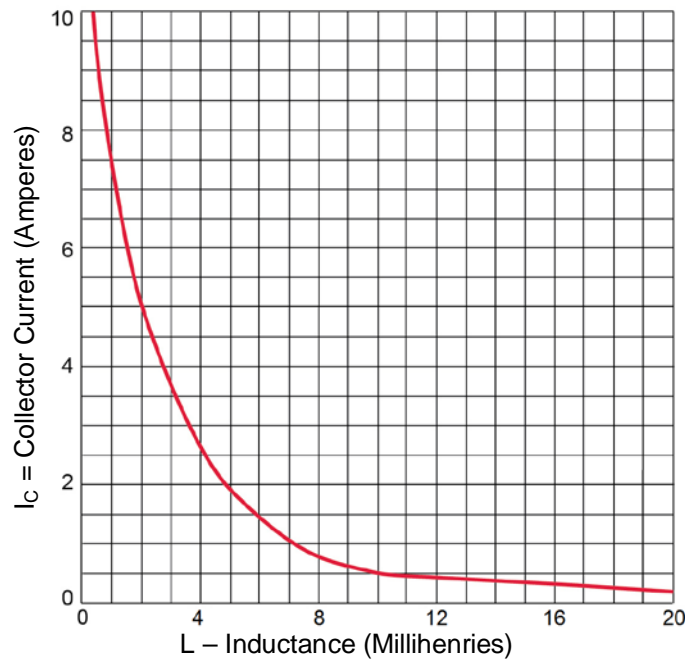
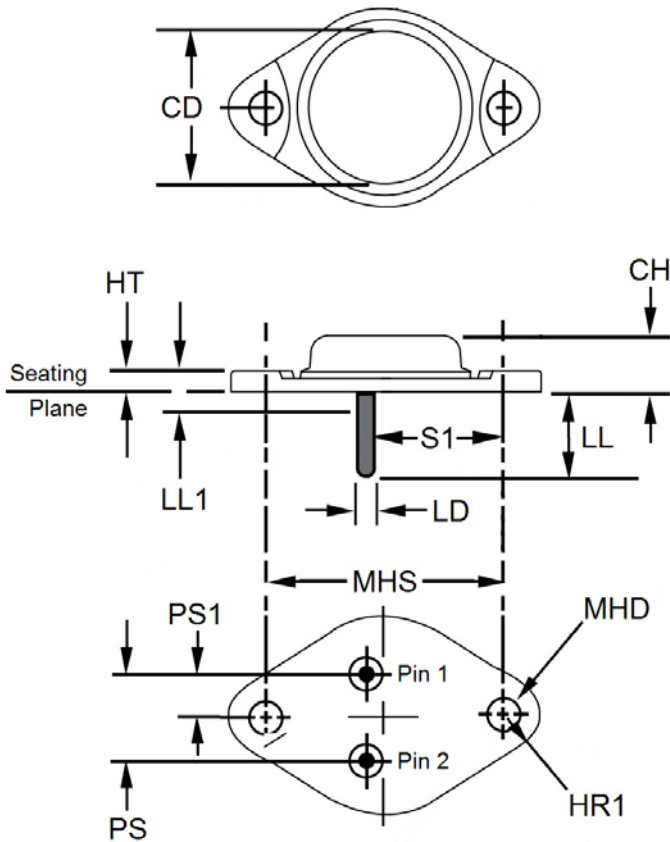


FIGURE 2
 Safe Operating Area for Switching Between Saturation and Cutoff (unclamped inductive load)

PACKAGE DIMENSIONS


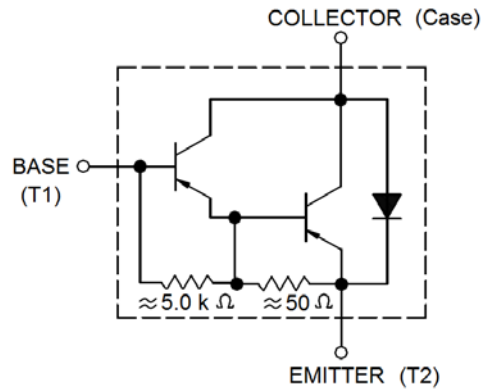
Ltr	Dimensions				Notes
	Inches		Millimeters		
	Min	Max	Min	Max	
CD	-	0.875	-	22.23	
CH	0.250	0.450	6.35	11.43	
HR	0.495	0.525	12.57	13.34	
HR1	0.131	0.188	3.33	4.78	
HT	0.050	0.135	1.52	3.43	
LD	0.038	0.043	0.97	1.09	
LL	0.312	0.500	7.92	12.70	
LL1	-	0.050	-	1.27	
MHD	0.151	0.161	3.84	4.09	
MHS	1.177	1.197	29.90	30.40	
PS	0.420	0.440	10.67	11.18	3
PS1	0.205	0.225	5.21	5.72	3
S1	0.655	0.675	16.64	17.15	

NOTES:

1. Dimensions are in inches.
2. Millimeters are given for information only.
3. These dimensions should be measured at points 0.050 inch (1.27 mm) and 0.055 inch (1.40 mm) below seating plane. When gauge is not used measurement will be made at the seating plane.
4. The seating plane of the header shall be flat within 0.001 inch (0.03 mm) concave to 0.004 inch (0.10 mm) convex inside a 0.930 inch (23.62 mm) diameter circle on the center of the header and flat within 0.001 inch (0.03 mm) concave to 0.006 inch (0.15 mm) convex overall.
5. Mounting holes shall be deburred on the seating plane side.
6. Collector is electrically connected to the case.
7. In accordance with AMSE Y14.5M, diameters are equivalent to Φ x symbology.

See schematic on next page

SCHEMATIC





Компания «ЭлектроПласт» предлагает заключение долгосрочных отношений при поставках импортных электронных компонентов на взаимовыгодных условиях!

Наши преимущества:

- Оперативные поставки широкого спектра электронных компонентов отечественного и импортного производства напрямую от производителей и с крупнейших мировых складов;
- Поставка более 17-ти миллионов наименований электронных компонентов;
- Поставка сложных, дефицитных, либо снятых с производства позиций;
- Оперативные сроки поставки под заказ (от 5 рабочих дней);
- Экспресс доставка в любую точку России;
- Техническая поддержка проекта, помощь в подборе аналогов, поставка прототипов;
- Система менеджмента качества сертифицирована по Международному стандарту ISO 9001;
- Лицензия ФСБ на осуществление работ с использованием сведений, составляющих государственную тайну;
- Поставка специализированных компонентов (Xilinx, Altera, Analog Devices, Intersil, Interpoint, Microsemi, Aeroflex, Peregrine, Syfer, Eurofarad, Texas Instrument, Miteq, Cobham, E2V, MA-COM, Hittite, Mini-Circuits, General Dynamics и др.);

Помимо этого, одним из направлений компании «ЭлектроПласт» является направление «Источники питания». Мы предлагаем Вам помощь Конструкторского отдела:

- Подбор оптимального решения, техническое обоснование при выборе компонента;
- Подбор аналогов;
- Консультации по применению компонента;
- Поставка образцов и прототипов;
- Техническая поддержка проекта;
- Защита от снятия компонента с производства.



Как с нами связаться

Телефон: 8 (812) 309 58 32 (многоканальный)

Факс: 8 (812) 320-02-42

Электронная почта: org@eplast1.ru

Адрес: 198099, г. Санкт-Петербург, ул. Калинина, дом 2, корпус 4, литера А.