



Main

Range of product	OsiSense XU
Series name	General purpose single mode
Electronic sensor type	Photo-electric sensor
Sensor name	XUX
Sensor design	Compact 92 x 71
Detection system	Diffuse with background suppression
Material	Plastic
Type of output signal	Discrete
Supply circuit type	AC/DC
Wiring technique	5-wire
Discrete output function	1 NO or 1 NC programmable
Electrical connection	Screw-clamp terminals, 1 x 0.75...1 x 1.5 mm ²
Product specific application	Long sensing distance with high accuracy
Emission	Infrared
[Sn] nominal sensing distance	6.56 ft (2 m)

Complementary

Enclosure material	PC
Lens material	PMMA
Output type	Relay
Cable entry	ISO 16 cable gland, cable outer diameter: 0.28...0.39 in (7...10 mm)
Status LED	1 LED (green) supply on 1 LED (red) instability 1 LED (yellow) output state
[Us] rated supply voltage	24...240 V AC/DC
Supply voltage limits	20...264 V AC/DC
Switching frequency	20 Hz
Voltage drop	<= 1.5 V (closed state)
Current consumption	35 mA (no-load)
Time delay range	0.02...15 s monostable, on delay or off-delay delay
Delay first up	< 200 ms
Delay response	< 25 ms
Delay recovery	< 25 ms
Electrical durability	500000 cycles, switching capacity: 0.5 A, cos φ = 0.4 500000 cycles, switching capacity: 3 A, cos φ = 1
Product weight	0.44 lb(US) (0.2 kg)

Environment

product certifications	CE CSA UL
ambient air temperature for operation	-13...131 °F (-25...55 °C)
ambient air temperature for storage	-40...158 °F (-40...70 °C)
vibration resistance	7 gn (f = 10...55 Hz) conforming to IEC 60068-2-6
shock resistance	10 gn (duration = 11 ms) conforming to IEC 60068-2-27
IP degree of protection	IP30 (with cover open) conforming to IEC 60529 IP65 (double insulation) conforming to IEC 60529 IP67 (double insulation) conforming to IEC 60529

The information provided in this documentation contains general descriptions and/or technical characteristics of the performance of the products contained herein. This documentation is not intended as a substitute for and is not to be used for determining suitability or reliability of these products for specific user applications. It is the duty of any such user or integrator to perform the appropriate and complete risk analysis, evaluation and testing of the products with respect to the relevant specific application or use thereof. Neither Schneider Electric Industries SAS nor any of its affiliates or subsidiaries shall be responsible or liable for misuse of the information contained herein.

Offer Sustainability

Not Green Premium product	Not Green Premium product
Compliant - since 1136 - Schneider Electric declaration of conformity	Compliant - since 1136 - Schneider Electric declaration of conformity
Reference not containing SVHC above the threshold	Reference not containing SVHC above the threshold
WARNING: This product can expose you to chemicals including:	WARNING: This product can expose you to chemicals including:
Diisononyl phthalate (DINP), which is known to the State of California to cause cancer, and	Diisononyl phthalate (DINP), which is known to the State of California to cause cancer, and
Diisodecyl phthalate (DIDP), which is known to the State of California to cause birth defects or other reproductive harm.	Diisodecyl phthalate (DIDP), which is known to the State of California to cause birth defects or other reproductive harm.
For more information go to www.p65warnings.ca.gov	For more information go to www.p65warnings.ca.gov

Contractual warranty

Warranty period	18 months
-----------------	-----------

Dimensions

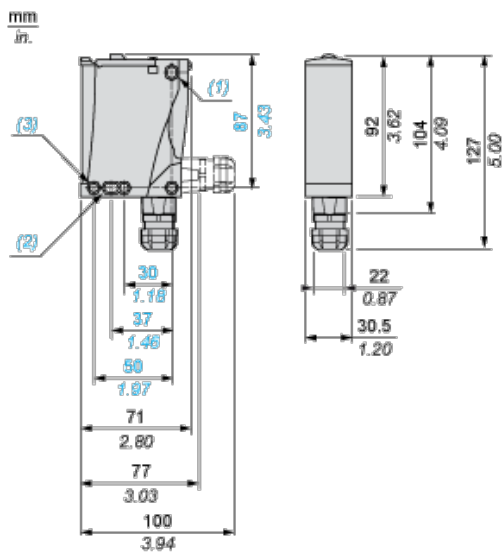

- (1) Elongated hole \varnothing 5.5 x 7
- (2) Elongated hole \varnothing 5.5 x 9
- (3) \varnothing 5.5 hole

Wiring Schemes

Relay Output AC/DC

Terminals		
1		AC/DC
2		AC/DC
3		NO
4		Relay common
5		NC

Detection Curves

Variation of Usable Sensing Distance S_u

Teach Mode at Minimum

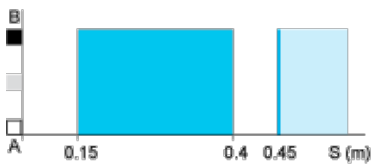

Teach Mode at Maximum

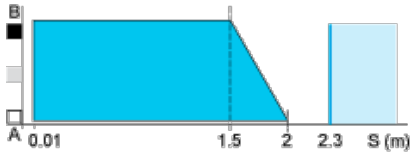

- (1) Black 6%
- (2) Grey 18%
- (3) White 90%
- (4) Sensing range
- (5) Non sensing zone (matt surfaces)

A-B :Object reflection coefficient

- (1) Black 6%
- (2) Grey 18%
- (3) White 90%
- (4) Sensing range
- (5) Non sensing zone (matt surfaces)

Detection Curves

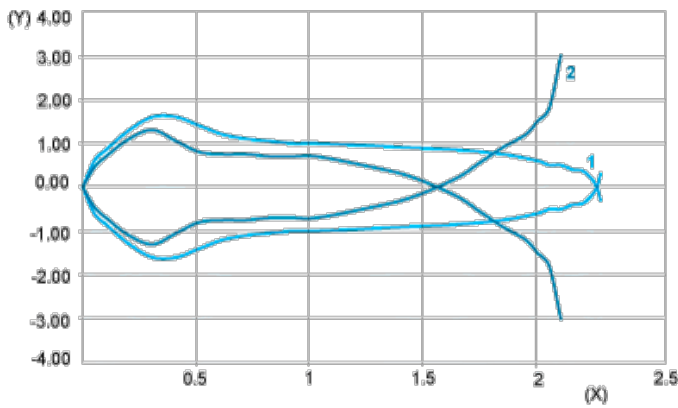

- 1 : White 90%
- 2 : Grey 18%
- (Y) Detection lobe (cm)
- (X) Object distance (m)
- Object 10 x 10 cm

Relative Difference in Sensing Distances According to Object Colour

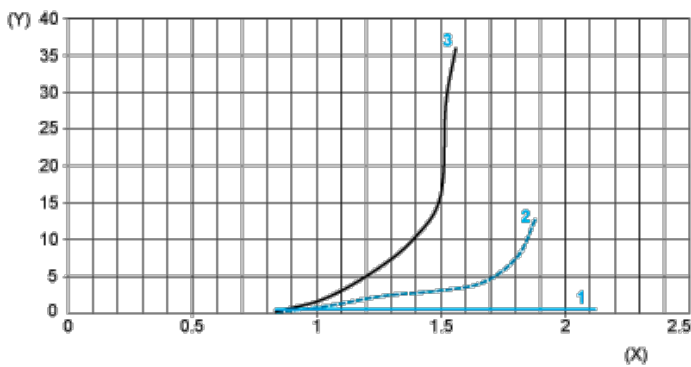

- 1 : White 90%
- 2 : Grey 18%
- 3 : Black 6%
- (Y) Relative error (%)
- (X) Object distance (m)
- Object 10 x 10 cm



Компания «ЭлектроПласт» предлагает заключение долгосрочных отношений при поставках импортных электронных компонентов на взаимовыгодных условиях!

Наши преимущества:

- Оперативные поставки широкого спектра электронных компонентов отечественного и импортного производства напрямую от производителей и с крупнейших мировых складов;
- Поставка более 17-ти миллионов наименований электронных компонентов;
- Поставка сложных, дефицитных, либо снятых с производства позиций;
- Оперативные сроки поставки под заказ (от 5 рабочих дней);
- Экспресс доставка в любую точку России;
- Техническая поддержка проекта, помощь в подборе аналогов, поставка прототипов;
- Система менеджмента качества сертифицирована по Международному стандарту ISO 9001;
- Лицензия ФСБ на осуществление работ с использованием сведений, составляющих государственную тайну;
- Поставка специализированных компонентов (Xilinx, Altera, Analog Devices, Intersil, Interpoint, Microsemi, Aeroflex, Peregrine, Syfer, Eurofarad, Texas Instrument, Miteq, Cobham, E2V, MA-COM, Hittite, Mini-Circuits, General Dynamics и др.);

Помимо этого, одним из направлений компании «ЭлектроПласт» является направление «Источники питания». Мы предлагаем Вам помощь Конструкторского отдела:

- Подбор оптимального решения, техническое обоснование при выборе компонента;
- Подбор аналогов;
- Консультации по применению компонента;
- Поставка образцов и прототипов;
- Техническая поддержка проекта;
- Защита от снятия компонента с производства.



Как с нами связаться

Телефон: 8 (812) 309 58 32 (многоканальный)

Факс: 8 (812) 320-02-42

Электронная почта: org@eplast1.ru

Адрес: 198099, г. Санкт-Петербург, ул. Калинина, дом 2, корпус 4, литера А.