

THIS DRAWING AND THE SUBJECT MATTER SHOWN THEREON ARE CONFIDENTIAL AND THE PROPERTY OF BEL/STEWART/TRP CONNECTOR AND SHALL NOT BE REPRODUCED, COPIED, OR USED IN ANY MANNER WITHOUT THE WRITTEN CONSENT OF TRP CONNECTOR.

PRODUCT MAY BE PROTECTED BY ONE OR MORE OF THE FOLLOWING US PATENTS:  
 5736910 5939955 6425781 6428361 6554638 6840817 7123117  
 7429195 7717749 7808751 6217391 6149050 7924130

REVISIONS				
#	LT#	DESCRIPTION	DATE	APPV
2		EC-1411035 COMPANY LOGO CHANGE	04JAN2015	DP TY

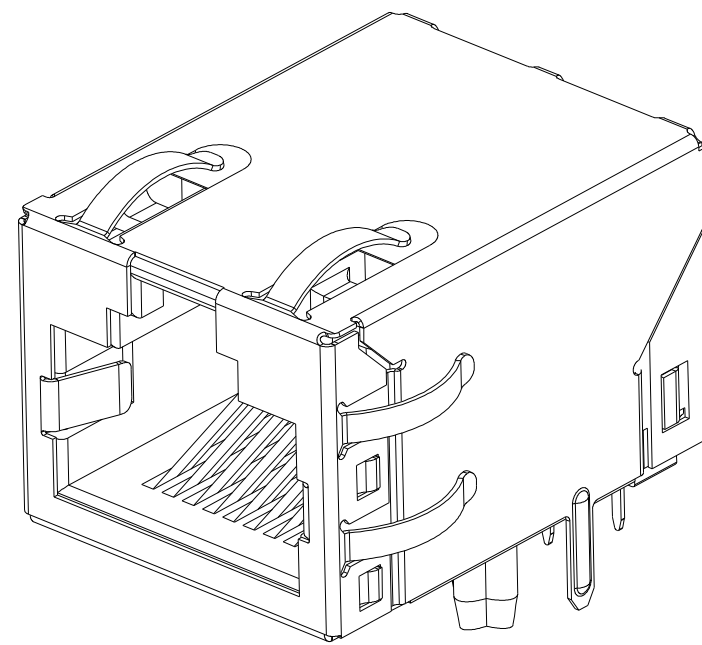
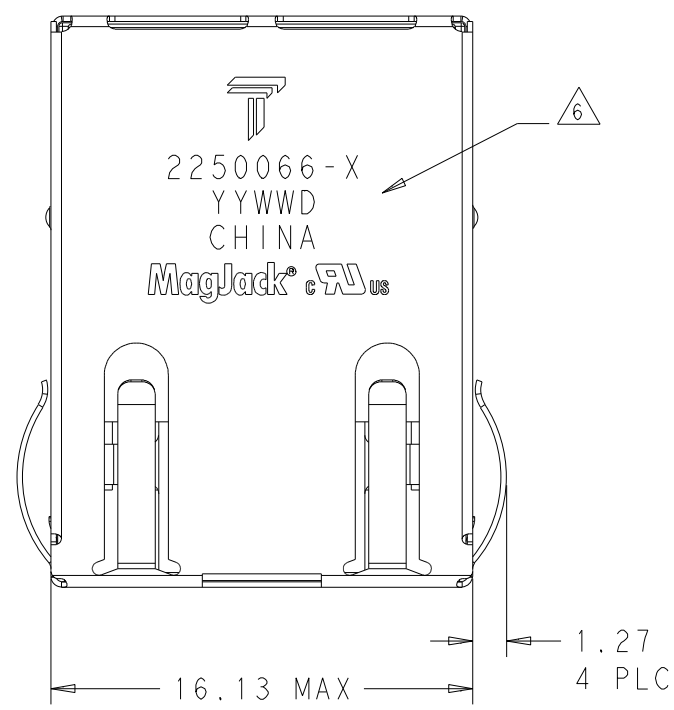

1. MATERIALS

- HOUSING: THERMOPLASTIC, FLAMMABILITY RATING UL 94V-0.
- SHIELD: BRASS 0.20mm THICK, PREPLATED WITH 0.76um MIN SEMI-BRIGHT NICKEL. SOLDER TABS POST DIPPED WITH 2.54um MIN SAC SOLDER.
- CONTACTS: PHOSPHOR BRONZE 0.46mm X 0.30mm, PHOSPHOR BRONZE, 1.27um MIN NICKEL UNDERPLATE, WITH 1.27um MIN GOLD PLATING AT MATING INTERFACE AND 2.54um MIN MATTE TIN ON SOLDER TAILS, OR 1.27um MIN NICKEL UNDERPLATE, WITH 0.05um GOLD PLATING OVER 0.76um MIN PALLADIUM NICKEL PLATING AT MATING INTERFACE AND 2.54um MIN MATTE TIN ON SOLDER TAILS.
- SOLDER TAILS: 0.25mm THICK, PHOSPHOR BRONZE, 1.27um MIN OVERALL NICKEL UNDERPLATE, 3um TIN PLATE

△ RJ45 JACK CAVITY CONFORMS TO FCC RULES AND REGULATIONS PART 68 SUB PART F.

△ MAGNETICS

- APPLICATION: 10/100 BASE-T, EXTENDED TEMPERATURE
- IMPEDANCE: 100 OHMS
- TURNS RATIO (CHIP:CABLE): TX = 1:1, RX = 1:1
- OPEN CIRCUIT INDUCTANCE (OCL): 350uH MIN @100kHz, 0.1VRMS, 8mADC BIAS FROM -40°C TO +85°C, TX AND RX
- PERFORMANCE @ 25°C:  
 INSERTION LOSS (IL): 1.1dB MAX FROM 0.5MHz TO 100MHz  
 RETURN LOSS (RL): 18dB MIN FROM 0.5MHz TO 30MHz  
 18-20LOG(f/30)dB MIN FROM 30.1MHz TO 60MHz  
 12dB MIN FROM 60.1MHz TO 80MHz  
 CROSSTALK ATTENUATION: 35dB MIN FROM 0.5MHz TO 40MHz  
 33-20LOG(f/50)dB MIN FROM 40.1MHz TO 100MHz  
 COMMON MODE REJECTION RATIO (CMRR): 30dB MIN FROM 0.5MHz TO 100MHz
- ISOLATION VOLTAGE: 2250VDC FOR 60 SECONDS WITH A RISE TIME OF 500 V/SEC

4. OPERATING TEMPERATURE: FROM -40°C TO +85°C.

△ INDICATED MAGNETIC CONNECTIONS ARE SYMMETRICAL TO SUPPORT AUTO-MDI/MDIX.

△ TRP CONNECTOR LOGO, PART NUMBER, DATE CODE, COUNTRY OF ORIGIN AND AGENCY APPROVAL MARKING IN APPROXIMATE LOCATION SHOWN. DATE CODE: YYWW WHERE YY IS YEAR, WW IS WORK WEEK, D IS DAY OF WEEK, WITH SUNDAY=1.

7. PART SHOULD BE RECOMMENDED FOR WAVE SOLDERING PROCESS, PREHEAT TEMPERATURE IS 120°C TO 160°C, 120 SECONDS TO 180 SECONDS, PEAK WAVE SOLDERING TEMPERATURE IS 260°C MAX, 10 SECONDS MAX.

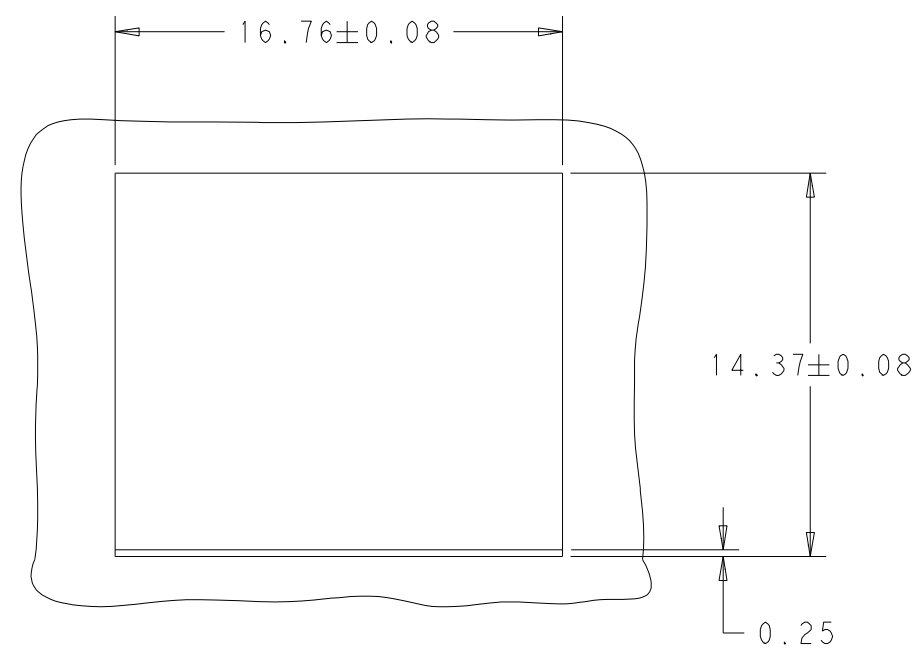
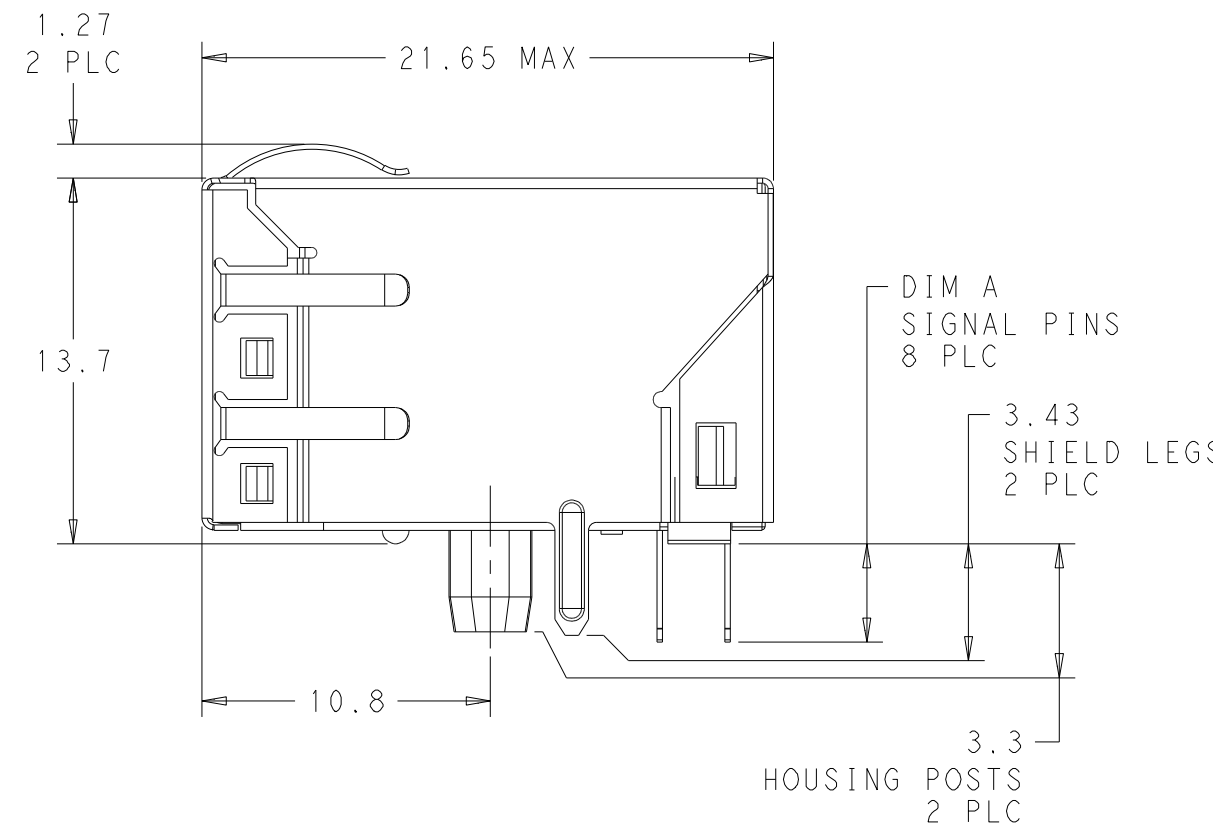
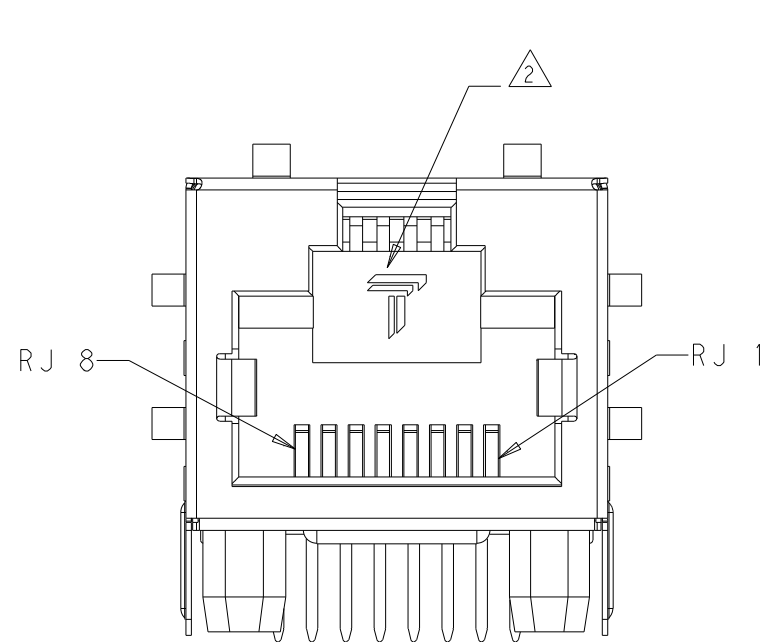

SUGGESTED PANEL CUTOUT

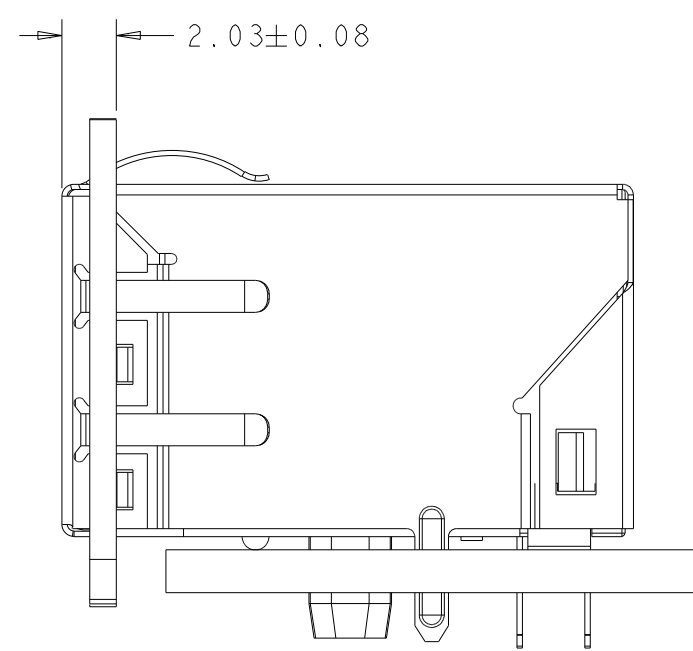

3.18	2250066-2
3.68	2250066-1
DIM A	PART NUMBER

THIS DRAWING IS A CONTROLLED DOCUMENT.		DWN	ROY LIU	17DEC2013
DIMENSIONS:		CHK	TOWER YU/ FRANK LIU	17DEC2013
mm		APPV	TONY YUAN	17DEC2013
TOLERANCES UNLESS OTHERWISE SPECIFIED:		MODEL NAME		
0 PLC	±0.25	MAGJACK		
1 PLC	±0.25	SIZE		
2 PLC	±0.25	CAGE CODE		
3 PLC	±0.25	DRAWING NO		
4 PLC	±0.25	RESTRICTED TO		
ANGLES	±	A 1		
PRODUCT SPEC	APPLICATION SPEC	C=2250066		
CUSTOMER DRAWING		SCALE		4:1
		SHEET		1 OF 3
		REV		2



DESC IXI 726ET 10/100 TAB UP W/O LED

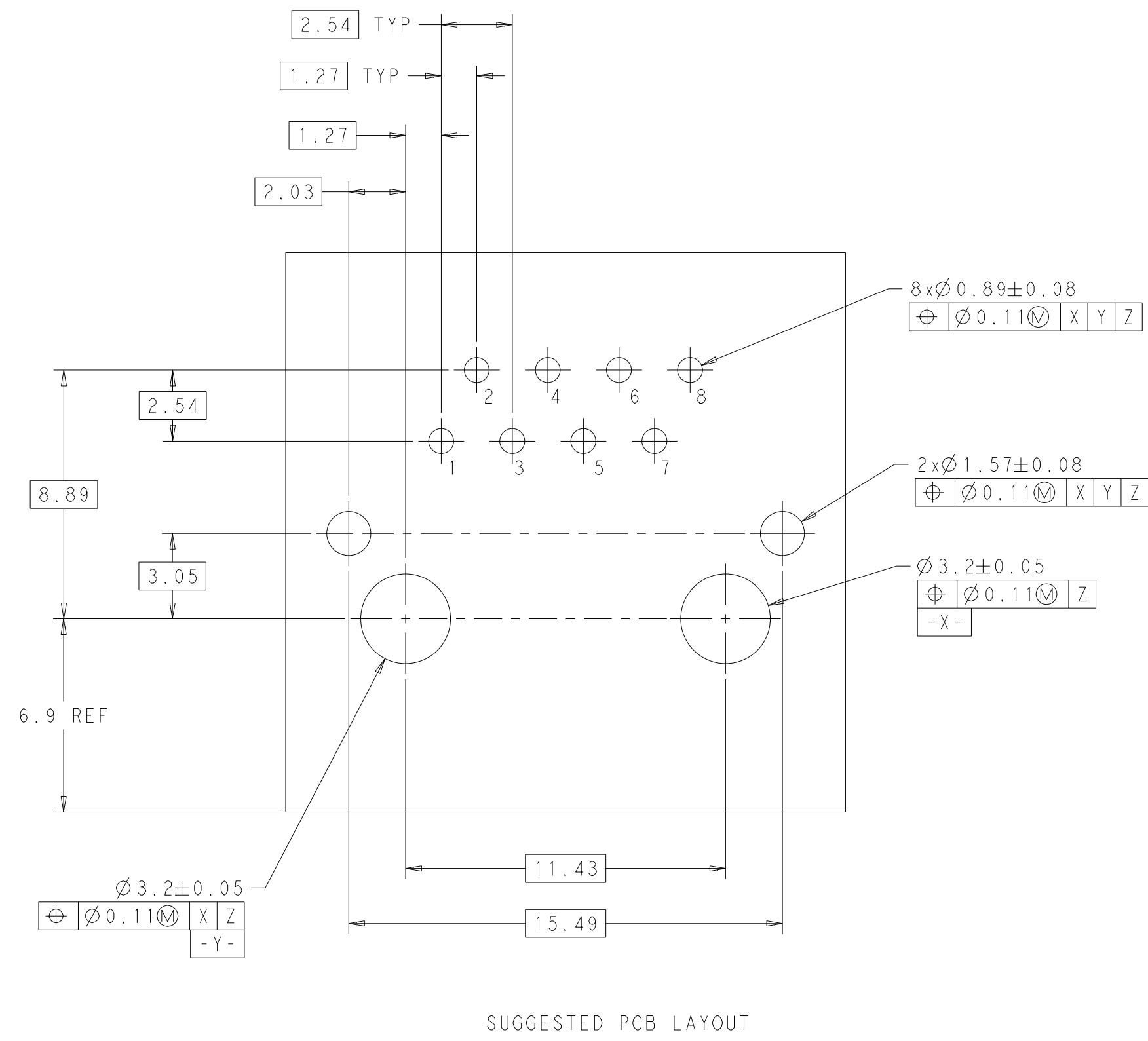

SUGGESTED PCB LAYOUT

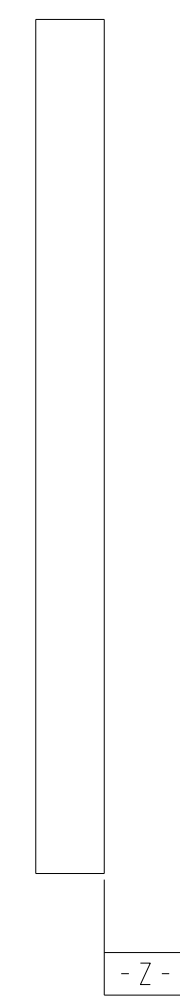

# 726ET 10/100 CIRCUIT $\triangle \triangle$

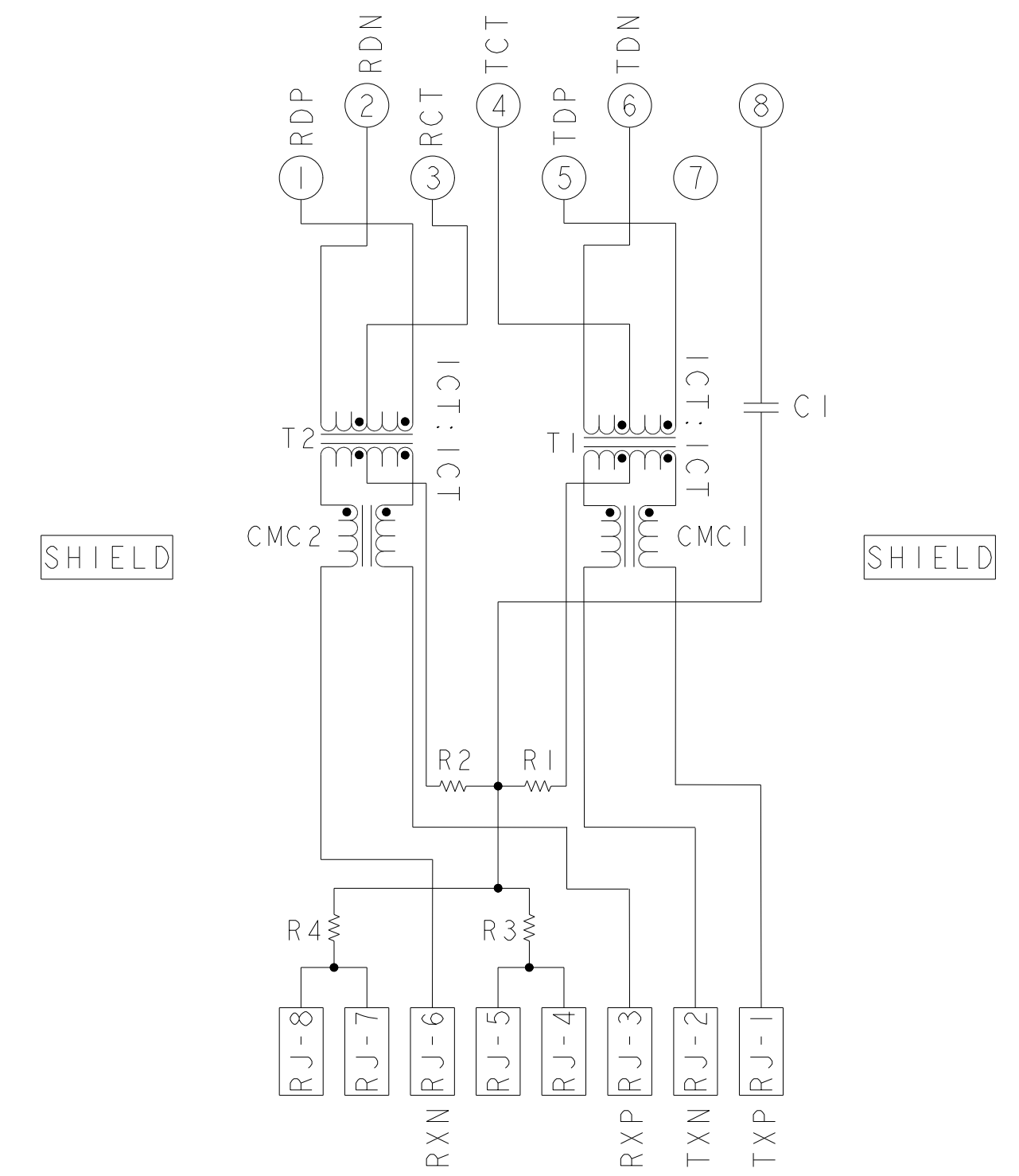

C1=1000pF, 2kV CAPACITOR  
 R1-R4 = 75 Ohms, 1/16 W RESISTORS

THIS DRAWING IS A CONTROLLED DOCUMENT.		OWN ROY LIU	17DEC2013	 <b>trp</b> CONNECTOR a bel group DONGGUAN CHINA	
DIMENSIONS: mm		CHK TOWER YU/ FRANK LIU	17DEC2013		
TOLERANCES UNLESS OTHERWISE SPECIFIED:		APVD TONY YUAN	17DEC2013		
0 PLC $\pm 0.25$ 1 PLC $\pm 0.25$ 2 PLC $\pm 0.25$ 3 PLC $\pm 0.25$ 4 PLC $\pm 0.25$ ANGLES $\pm$ APPLICATION SPEC $\pm$	MODEL NAME <b>MAGJACK</b> DESC SINGLE NON-POE CUSTOMER DRAWING	SIZE <b>A1</b>	CAGE CODE <b>C=2250066</b>	DRAWING NO <b>2250066</b>	RESTRICTED TO -
SCALE 4:1		SHEET 2 OF 3		REV 2	

C_2250066					STOCK DISPOSITION			
					A: CONTINUE AS IS B: REWORK C: SCRAP		D: USE OLD FIRST E: PARTS TO CONFORM F: OTHER	
REVISION HISTORY								
DATE	REV	CHANGES	REASON	APPROVAL	INVENTORY (A,B,C,D,E,F)	WORK IN PROCESS (A,B,C,F)	SUPPLIER ORDERS (A,E,F)	OPEN CUST ORDERS (A,E,F)
17DEC2013	1	-	INITIAL RELEASE	TONY YUAN	-	-	-	-
04JAN2015	2	EC-1411035 COMPANY LOGO CHANGE	MARKET REQUEST	TONY YUAN	-	-	-	-

THIS DRAWING IS A CONTROLLED DOCUMENT.

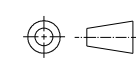
DIMENSIONS: mm	TOLERANCES UNLESS OTHERWISE SPECIFIED: 0 PLC ±0.25 1 PLC ±0.25 2 PLC ±0.25 3 PLC ±0.25 4 PLC ± ANGLES ±	OWN ROY LIU 17DEC2013 CHK TOWER YU/ FRANK LIU 17DEC2013 APPRO TONY YUAN 17DEC2013	 <b>trp</b> CONNECTOR a bel group DONGGUAN CHINA
 PRODUCT SPEC -	APPLICATION SPEC -	MODEL NAME MAGJACK SINGLE NON-POE CUSTOMER DRAWING	
		SIZE A1	DESC IXI 726ET 10/100 TAB UP W/O LED
		SCALE 4:1	RESTRICTED TO -
		SHEET 3 OF 3	REV 2



Компания «ЭлектроПласт» предлагает заключение долгосрочных отношений при поставках импортных электронных компонентов на взаимовыгодных условиях!

Наши преимущества:

- Оперативные поставки широкого спектра электронных компонентов отечественного и импортного производства напрямую от производителей и с крупнейших мировых складов;
- Поставка более 17-ти миллионов наименований электронных компонентов;
- Поставка сложных, дефицитных, либо снятых с производства позиций;
- Оперативные сроки поставки под заказ (от 5 рабочих дней);
- Экспресс доставка в любую точку России;
- Техническая поддержка проекта, помощь в подборе аналогов, поставка прототипов;
- Система менеджмента качества сертифицирована по Международному стандарту ISO 9001;
- Лицензия ФСБ на осуществление работ с использованием сведений, составляющих государственную тайну;
- Поставка специализированных компонентов (Xilinx, Altera, Analog Devices, Intersil, Interpoint, Microsemi, Aeroflex, Peregrine, Syfer, Eurofarad, Texas Instrument, Miteq, Cobham, E2V, MA-COM, Hittite, Mini-Circuits, General Dynamics и др.);

Помимо этого, одним из направлений компании «ЭлектроПласт» является направление «Источники питания». Мы предлагаем Вам помощь Конструкторского отдела:

- Подбор оптимального решения, техническое обоснование при выборе компонента;
- Подбор аналогов;
- Консультации по применению компонента;
- Поставка образцов и прототипов;
- Техническая поддержка проекта;
- Защита от снятия компонента с производства.



#### Как с нами связаться

**Телефон:** 8 (812) 309 58 32 (многоканальный)

**Факс:** 8 (812) 320-02-42

**Электронная почта:** [org@eplast1.ru](mailto:org@eplast1.ru)

**Адрес:** 198099, г. Санкт-Петербург, ул. Калинина, дом 2, корпус 4, литера А.