

January 2007

Features

- 112 ms acoustic echo canceller
- Up to 12 dB of noise reduction
- Works with low cost voice codec. ITU-T G.711 or signed mag μ /A-Law, or linear 2's compliment
- Each port may operate independently in companded format or linear format
- Advanced NLP design - full duplex speech with no switched loss on audio paths
- Fast re-convergence time: tracks changing echo environment quickly
- Adaptation algorithm converges even during Double-Talk
- Designed for exceptional performance in high background noise environments
- Provides protection against narrow-band signal divergence
- Howling prevention stops uncontrolled oscillation in high loop gain conditions
- Programmable offset nulling of all PCM channels
- Serial micro-controller interface
- Idle channel noise suppression
- ST-BUS, GCI, or variable-rate SSI PCM interfaces

Ordering Information

ZL38002QDG	48 Pin TQFP	Trays
ZL38002QDG1	48 Pin TQFP*	Trays
ZL38002DGE1	36 Pin QSOP*	Tubes, Bake & Drypack
ZL38002DGF1	36 Pin QSOP*	Tape & Reel, Bake & Drypack

*Pb Free Matte Tin
-40°C to 85°C

- User gain control provided for speaker path (-24 dB to +21 dB in 3 dB steps)
- Adjustable gain pads from -24 dB to +21 dB at Xin, Sin and Sout to compensate for different system requirements
- AGC on speaker path
- Handles up to -6 dB acoustic echo return loss (with the appropriate gain pad settings)
- Transparent data transfer and mute options
- 20 MHz master clock operation
- Low power mode during PCM Bypass
- Bootloadable for future factory software upgrades
- 2.7 V to 3.6 V supply voltage; 5 V-tolerant inputs

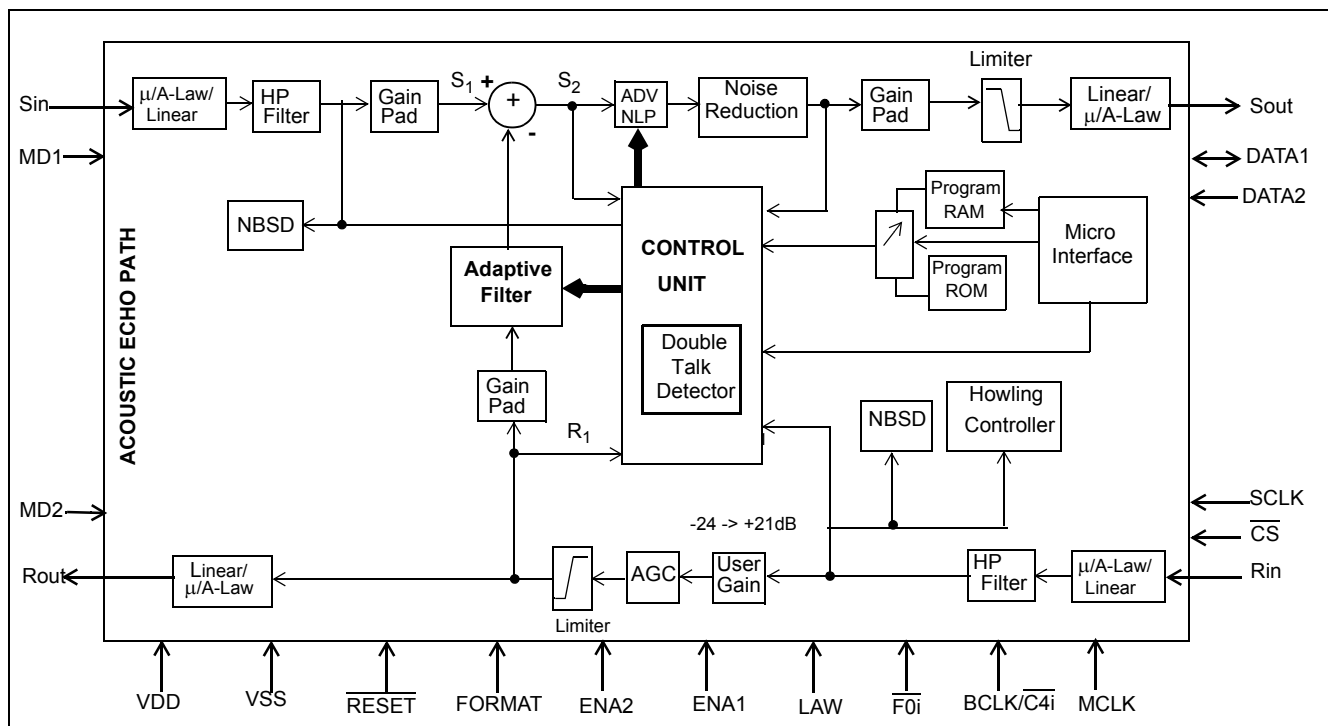

Figure 1 - Functional Block Diagram

Applications

- Hands free car kits
- Full duplex speaker-phone for digital telephone
- Echo cancellation for video conferencing
- Security systems
- Intercom systems (door entry, elevator, and restaurant drive-through)

	MT93L16	ZL38001	ZL38002	ZL38003
Description	AEC for analog hands-free communication	AEC for analog hands-free communication	AEC with noise reduction for digital hands-free communication	AEC with noise reduction & codecs for digital hands-free communication
Application	Analog Desktop phone Analog Intercom	Analog Desktop phone Analog Intercom	Hands-free Car Kits Digital Desktop Phone Home Security Intercom & Pedestals	Hands-free Car Kits Digital Desktop Phone Home Security Intercom & Pedestals
Features				
AEC	1 channel	1 channel	1 channel	1 channel
LEC	1 channel	1 channel	Custom Load	Custom Load
Gains	User Gain	User Gain/18 dB Gain on Sout	User Gain + System tuning gains	User Gain + System tuning gains
Noise Reduction	N	N	Y	Y
Integrated Codecs	N	N	N	dual channel

Table 1 - Acoustic Echo Cancellation Family

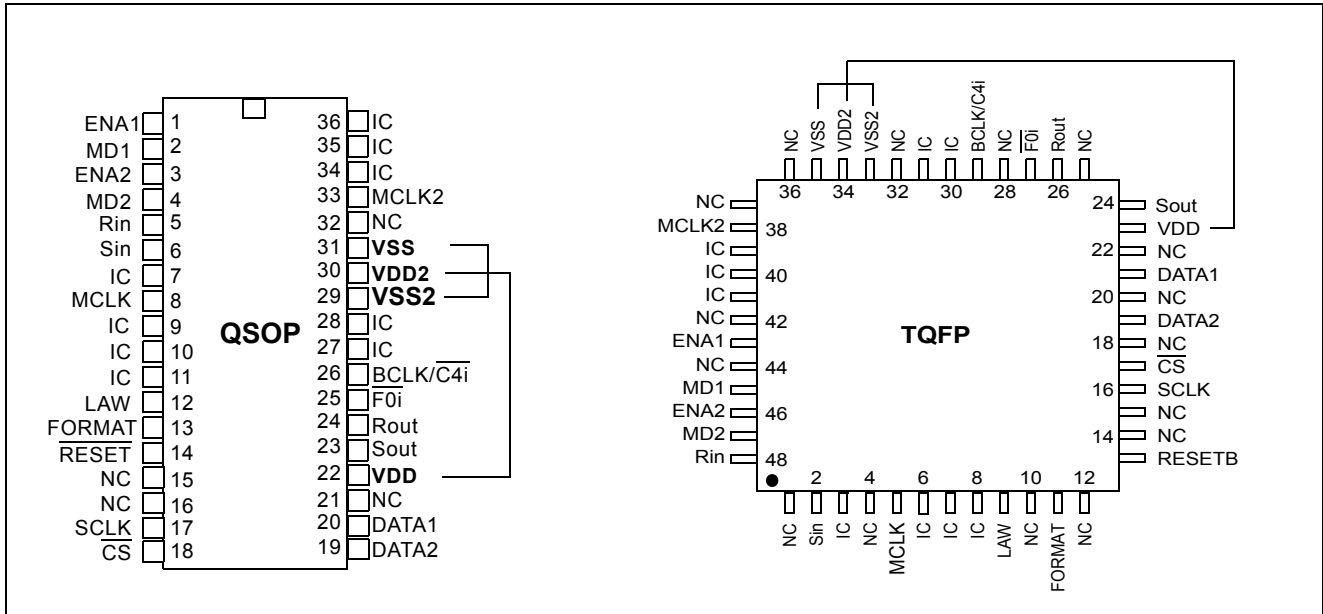

Figure 2 - Pin Connections

Pin Description

QSOP Pin #	TQFP Pin #	Name	Description
1	43	ENA1	SSI Enable Strobe/ST-BUS & GCI Mode for Rin/Sout (Input). This pin has dual functions depending on whether SSI or ST-BUS/GCI is selected. For SSI, this strobe must be present for frame synchronization. This is an active high channel enable strobe, 8 or 16 data bits wide, enabling serial PCM data transfer for on Rin/Sout pins. Strobe period is 125 ms. For ST-BUS or GCI, this pin, in conjunction with the MD1 pin, selects the proper mode for Rin/Sout pins (see ST-BUS and GCI Operation description).
2	45	MD1	ST-BUS & GCI Mode for Rin/Sout (Input). When in ST-BUS or GCI operation, this pin, in conjunction with the ENA1 pin, will select the proper mode for Rin/Sout pins (see ST-BUS and GCI Operation description). Connect this pin to Vss in SSI mode.
3	46	ENA2	SSI Enable Strobe /ST-BUS & GCI Mode for Sin/Rout (Input). This pin has dual functions depending on whether SSI or ST-BUS/GCI is selected. For SSI, this is an active high channel enable strobe, 8 or 16 data bits wide, enabling serial PCM data transfer on Sin/Rout pins. Strobe period is 125 ms. For ST-BUS/GCI, this pin, in conjunction with the MD2 pin, selects the proper mode for Sin/Rout pins (see ST-BUS and GCI Operation description).
4	47	MD2	ST-BUS & GCI Mode for Sin/Rout (Input). When in ST-BUS or GCI operation, this pin in conjunction with the ENA2 pin, selects the proper mode for Sin/Rout pins (see ST-BUS and GCI Operation description). Connect this pin to Vss in SSI mode.

Pin Description (continued)

QSOP Pin #	TQFP Pin #	Name	Description
5	48	Rin	Receive PCM Signal Input (Input). 128 kbps to 4096 kbps serial PCM input stream. Data may be in either companded or 2's complement linear format. This is the Receive Input channel from the line (or network) side. Data bits are clocked in following SSI, GCI or ST-BUS timing requirements.
6	2	Sin	Send PCM Signal Input (Input). 128 kbps to 4096 kbps serial PCM input stream. Data may be in either companded or 2's complement linear format. This is the Send Input channel (from the microphone). Data bits are clocked in following SSI, GCI or ST-BUS timing requirements.
7	3	IC	Internal Connection (Input). Must be tied to Vss.
8	5	MCLK	Master Clock (Input). Nominal 20 MHz Master Clock input (can be asynchronous relative to 8 KHz frame signal.) Tie together with MCLK2.
9,10,11	6, 7, 8	IC	Internal Connection (Input). Must be tied to Vss.
12	9	LAW	A/μ Law Select (Input). When low, selects μ-Law companded PCM. When high, selects A-Law companded PCM. This control is for both serial pcm ports.
13	11	FORMAT	ITU-T/Sign Mag (Input). When low, selects sign-magnitude PCM code. When high, selects ITU-T (G.711) PCM code. This control is for both serial pcm ports.
14	13	$\overline{\text{RESET}}$	Reset / Power-down (Input). An active low resets the device and puts the ZL38002 into a low-power stand-by mode.
17	16	SCLK	Serial Port Synchronous Clock (Input). Data clock for the serial microport interface.
18	17	$\overline{\text{CS}}$	Serial Port Chip Select (Input). Enables serial microport interface data transfers. Active low.
19	19	DATA2	Serial Data Receive (Input). In Motorola/National serial microport operation, the DATA2 pin is used for receiving data. In Intel serial microport operation, the DATA2 pin is not used and must be tied to Vss or Vdd.
20	21	DATA1	Serial Data Port (Bidirectional). In Motorola/National serial microport operation, the DATA1 pin is used for transmitting data. In Intel serial microport operation, the DATA1 pin is used for transmitting and receiving data.
22	23	VDD	Positive Power Supply (Input). Nominally 3.3 volts.
23	24	Sout	Send PCM Signal Output (Output). 128 kbps to 4096 kbps serial PCM output stream. Data may be in either companded or 2's complement linear PCM format. This is the Send Out signal after acoustic echo cancellation and non-linear processing. Data bits are clocked out following SSI, ST-BUS or GCI timing requirements.
24	26	Rout	Receive PCM Signal Output (Output). 128 kbps to 4096 kbps serial PCM output stream. Data may be in either companded or 2's complement linear PCM format. This is the Receive out signal after the AGC and gain control. Data bits are clocked out following SSI, ST-BUS or GCI timing requirements.

Pin Description (continued)

QSOP Pin #	TQFP Pin #	Name	Description
25	27	$\overline{F0i}$	Frame Pulse (Input). In ST-BUS (or GCI) operation, this is an active-low (or active-high) frame alignment pulse, respectively. SSI operation is enabled by connecting this pin to Vss.
26	29	BCLK/ $\overline{C4i}$	Bit Clock/ST-BUS Clock (Input). In SSI operation, BCLK pin is a 128 kHz to 4.096 MHz bit clock. This clock must be synchronous with ENA1 and ENA2 enable strobes. In ST-BUS or GCI operation, $\overline{C4i}$ pin must be connected to the 4.096 MHz (C4) system clock.
27, 28	30, 31	IC	Internal Connection (Input). Tie to Vss.
29	33	VSS2	Digital Ground (Input). Nominally 0 volts.
30	34	VDD2	Positive Power Supply (Input). Nominally 3.3 volts (tie together with VDD).
31	35	VSS	Digital Ground (Input). Nominally 0 volts (tie together with VSS2).
33	38	MCLK2	Master Clock (Input). Nominal 20 MHz master clock (tie together with MCLK).
34,35,36	39, 40, 41	IC	Internal Connection (Input). Tie to Vss.
15, 16, 21, 32	1, 4, 10, 12, 14, 15, 18, 20, 22, 25, 28, 32, 36, 37, 42, 44	NC	No Connect (Output). This pin should be left unconnected.

Table of Contents

1.0 Changes Summary	9
2.0 Functional Description	9
2.1 Noise Reduction	9
2.2 Noise Suppression	10
2.3 Adaptation Speed Control	10
2.4 Advanced Non-Linear Processor (ADV-NLP)	10
2.5 Narrow Band Signal Detector (NBSD)	10
2.6 Howling Detector (HWLD)1	10
2.7 Programmable High Pass Filter	10
2.8 Limiters	11
2.9 User Gain	11
2.10 AGC	11
2.11 Programmable Gain Pad	11
2.12 Mute Function	11
2.13 Master Bypass	12
2.14 AEC Bypass	12
2.15 Adaptation Control	12
2.16 Throughput Delay	12
2.17 Power Down / Reset	12
3.0 PCM Data I/O	13
3.1 ST-BUS and GCI Operation	13
3.2 SSI Operation	16
3.3 PCM Law and Format Control (LAW, FORMAT)	17
3.4 Linear PCM	18
3.5 Bit Clock (BCLK/C4i)	18
3.6 Master Clock (MCLK)	18
4.0 Microport	18
5.0 Bootload Process and Execution from RAM	19
6.0 Register Summary	23
7.0 Register Definitions	25
8.0 Electrical Characteristics	42

List of Figures

Figure 1 - Functional Block Diagram	1
Figure 2 - Pin Connections	3
Figure 3 - ST-BUS and GCI 8-Bit Companded PCM I/O on Timeslot 0 (Mode 1)	13
Figure 4 - ST-BUS and GCI 8-Bit Companded PCM I/O on Timeslot 2 (Mode 2)	14
Figure 5 - ST-BUS and GCI 8-Bit Companded PCM I/O with D and C channels (Mode 3)	15
Figure 6 - ST-BUS and GCI 16-Bit 2's Complement Linear PCM I/O (Mode 4)	16
Figure 7 - SSI Operations	17
Figure 8 - Serial Microport Timing for Intel Mode 0	21
Figure 9 - Serial Microport Timing for Motorola Mode 00 or National Microwire	22
Figure 10 - Automatic Rout Gain Reduction (RoutGR)	36
Figure 11 - Master Clock - MCLK	44
Figure 12 - GCI Data Port Timing	45
Figure 13 - ST-BUS Data Port Timing	45
Figure 14 - SSI Data Port Timing	46
Figure 15 - INTEL Serial Microport Timing	46
Figure 16 - Motorola Serial Microport Timing	47

List of Tables

Table 1 - Acoustic Echo Cancellation Family	2
Table 2 - Quiet PCM Code Assignment	12
Table 3 - ST-BUS & GCI Mode Select	16
Table 4 - SSI Enable Strobe Pins	17
Table 5 - Companded PCM	18
Table 6 - Bootload RAM Control (BRC) Register States	20
Table 7 - Address Map	23
Table 8 - Reference Level Definition for Timing Measurements	44

1.0 Changes Summary

The following table captures the changes from the November 2005 issue.

Page	Item	Change
1		Updated Ordering Information

2.0 Functional Description

The ZL38002 device is comprised of an acoustic echo canceller and the necessary control functions for operation. The ZL38002 guarantees clear signal transmission in both transmit and receive audio path directions to ensure reliable voice communication, even when low level signals are provided. The ZL38002 does not use variable attenuators during double-talk or single-talk periods of speech, as do many other acoustic echo cancellers for speakerphones. Instead, the ZL38002 provides high performance full-duplex operation similar to network echo cancellers. This results in users experiencing clear speech and uninterrupted background signals during the conversation and prevents subjective sound quality problems associated with “noise gating” or “noise contrasting”.

The ZL38002 uses an advanced adaptive filter algorithm that is double-talk stable, which means that convergence takes place even while both parties are talking. This algorithm allows continual tracking of changes in the echo path, regardless of double-talk, as long as a reference signal is available for the echo canceller.

The echo tail cancellation capability of the acoustic echo canceller has been sized appropriately (112 ms) to cancel echo in an average sized office with a reverberation time of less than 112 ms.

In addition to the echo cancellers, the following functions are supported:

- 12 dB of noise reduction
- User gain pads at the Sin and Sout ports plus one at the input of adaptive filter (XRAM)
- Control of adaptive filter convergence speed during periods of double-talk, far end single-talk and near-end echo path changes
- Control of Non-Linear Processor thresholds for suppression of residual non-linear echo
- Howling detector to identify when instability is starting to occur and to take action to prevent oscillation
- Narrow-Band Detector for preventing adaptive filter divergence caused by narrow-band signals
- Programmable high pass filters at Rin and Sin for removal of DC components in PCM channels
- Limiters that introduce controlled saturation levels
- Serial controller interface compatible with Motorola, National and Intel microcontrollers
- PCM encoder/decoder compatible with m/A-Law ITU-T G.711, m/A-Law Sign-Mag or linear 2's complement coding
- Automatic gain control on the receive speaker path
- Idle channel noise suppression

2.1 Noise Reduction

The ZL38002 incorporates a noise reduction circuit that reduces background noise up to 12 dB. The level of noise reduction is programmed allowing the user to adjust the level of noise cancellation according to system requirements. This is controlled through the NR register on page 3 address 16_H. A larger value in this register will increase the amount of noise reduction. As the amount of noise reduction is increased the amount of distortion in the audio path also increases. The noise reduction can be bypassed by setting bit 4 in Control Register 1 (Address 01_H)

2.2 Noise Suppression

The ZL38002 also utilizes noise suppression which can be used to reduce idle channel noise from emanating from the acoustic end. By setting a threshold value in the lower nibble (bits 0-3) of the MCR2 register on page 0 address 01_H, idle channel noise below the threshold is zero-forced. The threshold limits ranges from 0 to 16 (based on a 16 bit 2's complement) with a value of 0 disabling suppression.

2.3 Adaptation Speed Control

The adaptation speed of the acoustic echo canceller is designed to optimize the convergence speed versus divergence caused by interfering near-end signals. Adaptation speed algorithm takes into account many different factors such as relative double-talk condition, far end signal power, echo path change and noise levels to achieve fast convergence.

2.4 Advanced Non-Linear Processor (ADV-NLP)

After echo cancellation, there is likely to be residual echo which needs to be removed so that it will not be audible. The ZL38002 uses an NLP to remove low level residual echo signals which are not comprised of background noise. The operation of the NLP depends upon a dynamic activation threshold, as well as a double-talk detector which disables the NLP during double-talk periods.

The ZL38002 keeps the perceived noise level constant, without the need for any variable attenuators or gain switching that causes audible "noise gating". The noise level is constant and identical to the original background noise even when the NLP is activated.

The NLP can be disabled by setting the NLP- bit to 1 in the AEC control registers.

2.5 Narrow Band Signal Detector (NBSD)¹

Single or multi-frequency tones (e.g., DTMF, or signalling tones) present in the reference input of an echo canceller for a prolonged period of time may cause the adaptive filter to diverge. The Narrow Band Signal Detector (NBSD) is designed to prevent this divergence by detecting single or multi-tones of arbitrary frequency, phase, and amplitude. When narrow band signals are detected, the filter adaptation process is stopped but the echo canceller continues to cancel echo.

The NBSD can be disabled by setting the NB- bit to 1 in the MC control registers.

2.6 Howling Detector (HWLD)¹

The Howling detector is part of an Anti-Howling control, designed to prevent oscillation as a result of positive feedback in the audio paths.

The HWLD can be disabled by setting the AH- bit to 1 in the (MC) control register.

2.7 Programmable High Pass Filter

Programmable high pass filters are placed at the Sin and Rin ports. These filters have two functions, one to remove any DC offset that may be present on either the Rin or the Sin port and two, to filter low frequency noise such as road noise (below 300 Hz).

The offset null filters can be disabled by setting the HPF- bit to 1 in the AEC control registers.

1. Patented

2.8 Limiters

To prevent clipping in the echo paths, two limiters with variable thresholds are provided at the outputs.

2.9 User Gain

The user gain function provides the ability for users to adjust the audio gain on all paths. This gain is adjustable from -24 dB to +21 dB in 3 dB steps for the Sout and Rout paths. It is important to use ONLY this user gain function to adjust the speaker volume. The user gain function in the ZL38002 is optimally placed outside the echo path such that no reconvergence is necessary after gain changes, avoiding a burst of each overtime the speaker gain is changed.

2.10 AGC

The AGC function is provided to limit the volume in the speaker path. The gain of the speaker path is automatically reduced during the following conditions:

- When clipping of the receive signal occurs
- When initial convergence of the acoustic echo canceller detects unusually large echo return
- When howling is detected

The AGC can be disabled by setting the AGC- bit to 1 in MC control register

2.11 Programmable Gain Pad

The ZL38002 has three gain pads located at Sin, Sout and at the adaptive filter (Xin). These gain pads are intended to be set once during initialization and not be used as dynamic gain adjustments. The purpose of these gainpads are to help fine tune the performance of the acoustic echo canceller for a particular system.

For example, the gain pad can be used to improve the subjective quality in low ERL environments. The ZL38002 can cancel echo with a ERL as low as 0 dB (attenuation from Rout to Sin). In many hand free applications, the ERL can be low (or negative). This is due to both speaker and microphone gain setting. The speaker gain has to be set high enough for the speaker to be heard properly and the microphone gain needs to be set high enough to ensure sufficient signal is sent to the far end. If the ERL (Acoustic Attenuation - speaker gain - microphone gain) is greater than 0 dB, then the echo canceller cannot cancel echo. To overcome this limitation, the gain pad at Sin and Sout can be used to lower the Sin level (and therefore the ERL) by 6 dB, perform the echo cancellation then amplify it at Sout by 6 dB. This will have the effect having 0dB gain between Sin and Sout for double talk signals while injecting a additional 6 dB attenuation for the echo return. It is important to reduce the DTDT threshold (Page 0 address 30) to match the Sin/Sout gain settings.

The gain can be accessed through Customer Gain Control Registers 1 - 2 (Page 0, Address 1C_H - 1D_H).

2.12 Mute Function

A pcm mute function is provided for independent control of the Receive and Send audio paths. Setting the MUTE_R or MUTE_S bit in the MC register, causes quiet code to be transmitted on the Rout or Sout paths respectively. The ZL38002 has an optional DC offset control. The user can add a positive offset to the mute value. This is controlled through the DC offset register (Page 0, Address 03h)

Quiet code is defined according to the following table.

	LINEAR 16 bits 2's complement	SIGN/ MAGNITUDE μ -Law A-Law	CCITT (G.711)	
			μ -Law	A-Law
+Zero (quiet code)	0000h	80h	FFh	D5h

Table 2 - Quiet PCM Code Assignment

2.13 Master Bypass

A PCM bypass function is provided to allow transparent transmission of pcm data through the ZL38002. When the bypass function is active, PCM data passes transparently from Rin to Rout and from Sin to Sout, with bit-wise integrity preserved.

When the Bypass function is selected, most internal functions are powered down to provide low power consumption.

The BYPASS control bit is located in the main control MC register.

2.14 AEC Bypass

An AEC bypass function is provided to allow the user to bypass only the AEC (i.e the echo estimate from the adaptive filter is not subtracted from the Send path). This bypass does not effect any other function in the ZL38002.

The AEC BYPASS control bit is located in the Acoustic Echo Canceller Control Register (AEC CR).

2.15 Adaptation Control

Adaptation control bit is located in the Acoustic Echo Canceller Control Register (Page 0, Address 21h). When the ADAPT- bit is set to 1, the adaptive filter is frozen at the current state. In this state, the device continues to cancel echo with the current echo model.

When the ADAPT- bit is set to 0, the adaptive filter is continually updated allowing the echo cancellor to adapt and track changes in the echo path. This is the normal operating state ZL38002

2.16 Throughput Delay

In all modes, except ST-BUS/GCI operation, voice channels have 2 frames of constant delay. In ST-BUS/ $\overline{\text{GCI}}$ operation, the D and C channels have a delay of one frame.

2.17 Power Down / Reset

Holding the $\overline{\text{RESET}}$ pin at logic low will keep the ZL38002 device in a power-down state. In this state all internal clocks are halted, and the DATA1, Sout and Rout pins are tristated.

The user should hold the $\overline{\text{RESET}}$ pin low for at least 200 msec following power-up. This will insure that the device powers up in a proper state. Following any return of $\overline{\text{RESET}}$ to logic high, the user must wait for 8 complete 8 KHz frames prior to writing to the device registers. During this time, the initialization routines will execute and set the ZL38002 to default operation based on the installed algorithm.

3.0 PCM Data I/O

The PCM data transfer for the ZL38002 is provided through two PCM ports. One port consists of Rin and Sout pins while the second port consists of Sin and Rout pins. The data are transferred through these ports according to either ST-BUS, GCI or SSI conventions detected automatically by the device. The ZL38002 determines the convention by monitoring the signal applied to the F0i pin. When a valid ST-BUS (active low) frame pulse is applied to the F0i pin, the ZL38002 will assume ST-BUS operation. When a valid GCI (active high) frame pulse is applied to the F0i pin, the device will assume GCI operation. If F0i is tied continuously to Vss, the device is set to SSI operation. Figures 3 to 6 show timing diagrams of these 3 PCM-interface operation conventions.

3.1 ST-BUS and GCI Operation

The ST-BUS PCM interface conforms to Zarlink's ST-BUS standard with an active-low frame pulse. Input data is clocked in by the rising edge of the bit clock (C4i) three-quarters of the way into the bit cell and output data bit boundaries (Rout, Sout) occur every second falling edge of the bit clock (see Figure 11.) The GCI PCM interface corresponds to the GCI standard commonly used in Europe with an active-high frame pulse. Input data is clocked in by the falling edge of the bit clock (C4i) three-quarters of the way into the bit cell and output data bit boundaries (Rout, Sout) occur every second rising edge of the bit clock (see Figure 12.)

Either of these interfaces (ST-BUS or GCI) can be used to transport 8 bit companded PCM data (using one timeslot) or 16 bit 2's complement linear PCM data (using two timeslots). The MD1/ENA1 pins select the timeslot on the Rin/Sout port while the MD2/ENA2 pin selects the timeslot on the Sin/Rout port, as in Table 2. Figures 3 to 6 illustrate the timeslot allocation for each of these four modes.

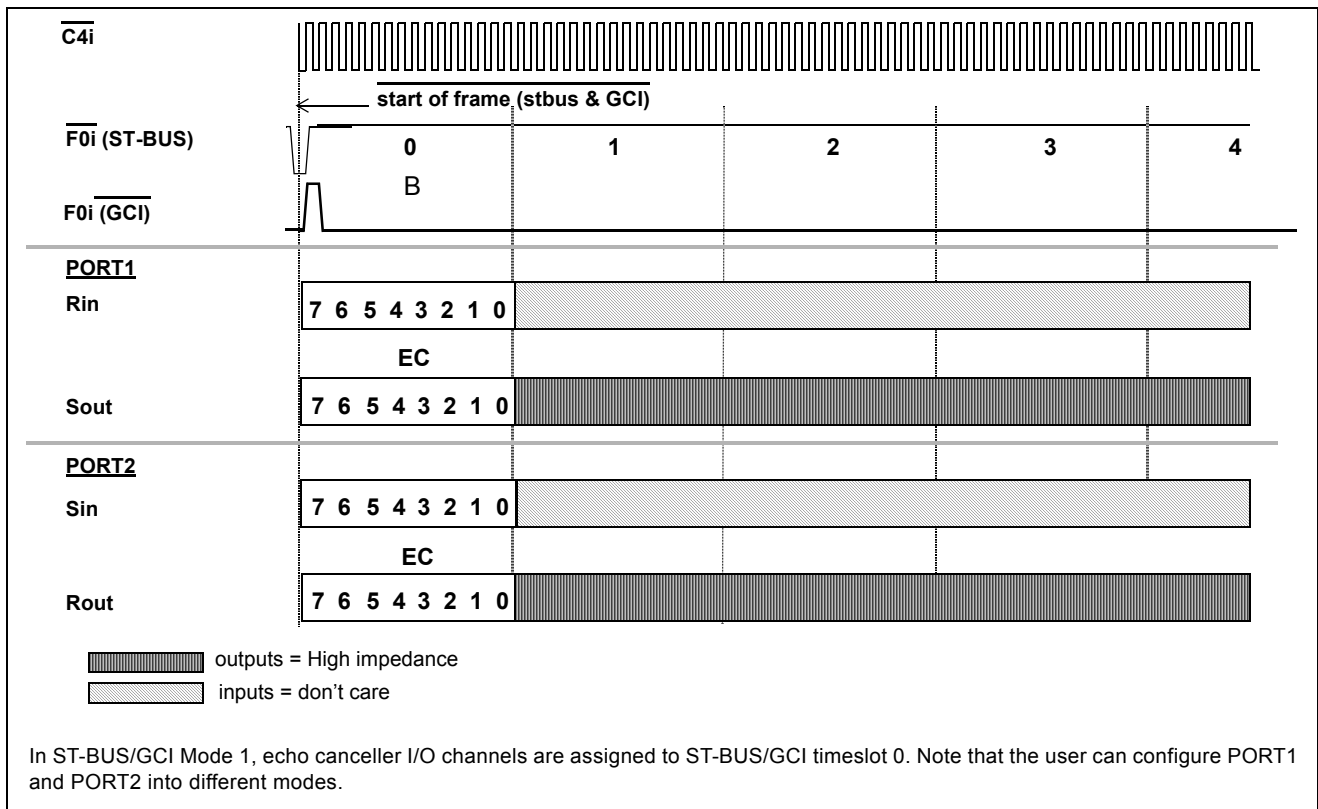

Figure 3 - ST-BUS and GCI 8-Bit Companded PCM I/O on Timeslot 0 (Mode 1)

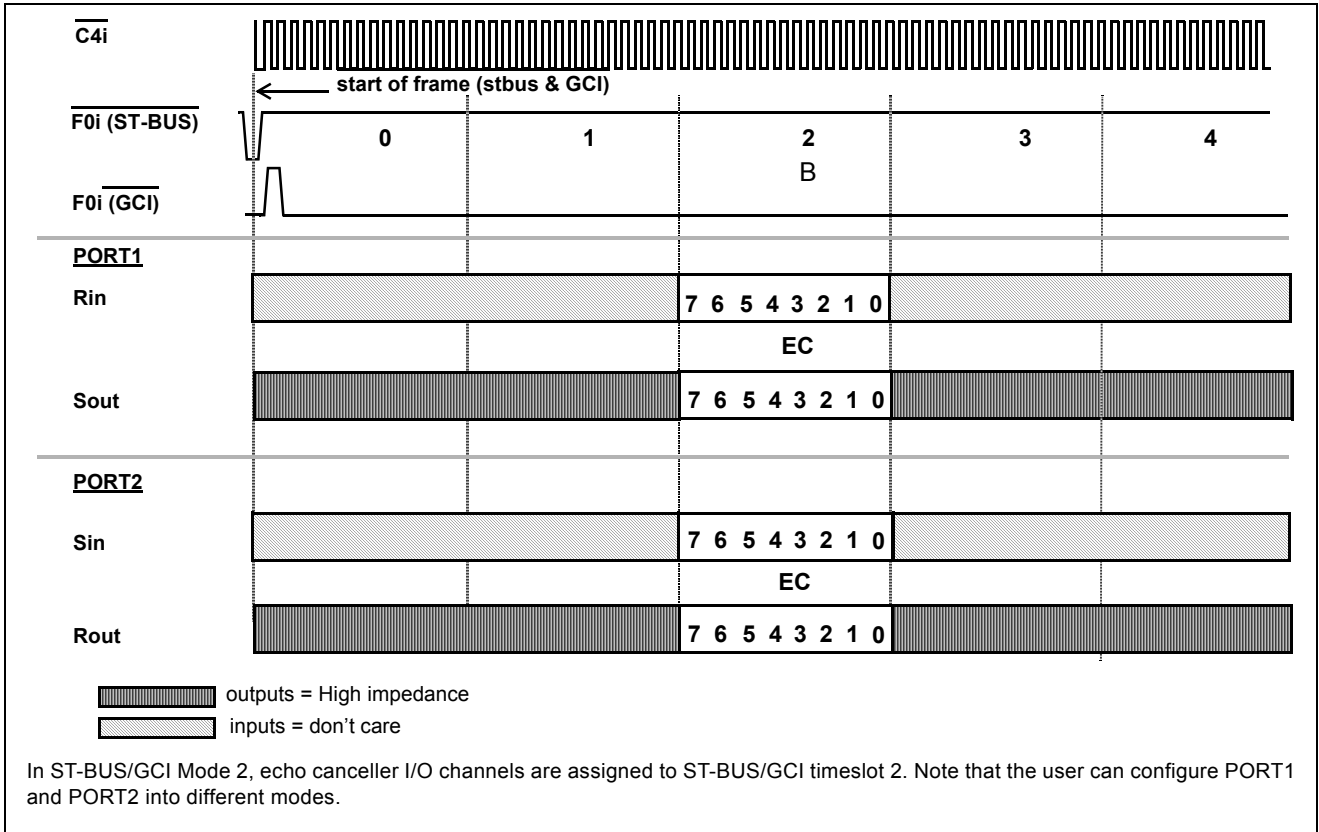

Figure 4 - ST-BUS and GCI 8-Bit Companded PCM I/O on Timeslot 2 (Mode 2)

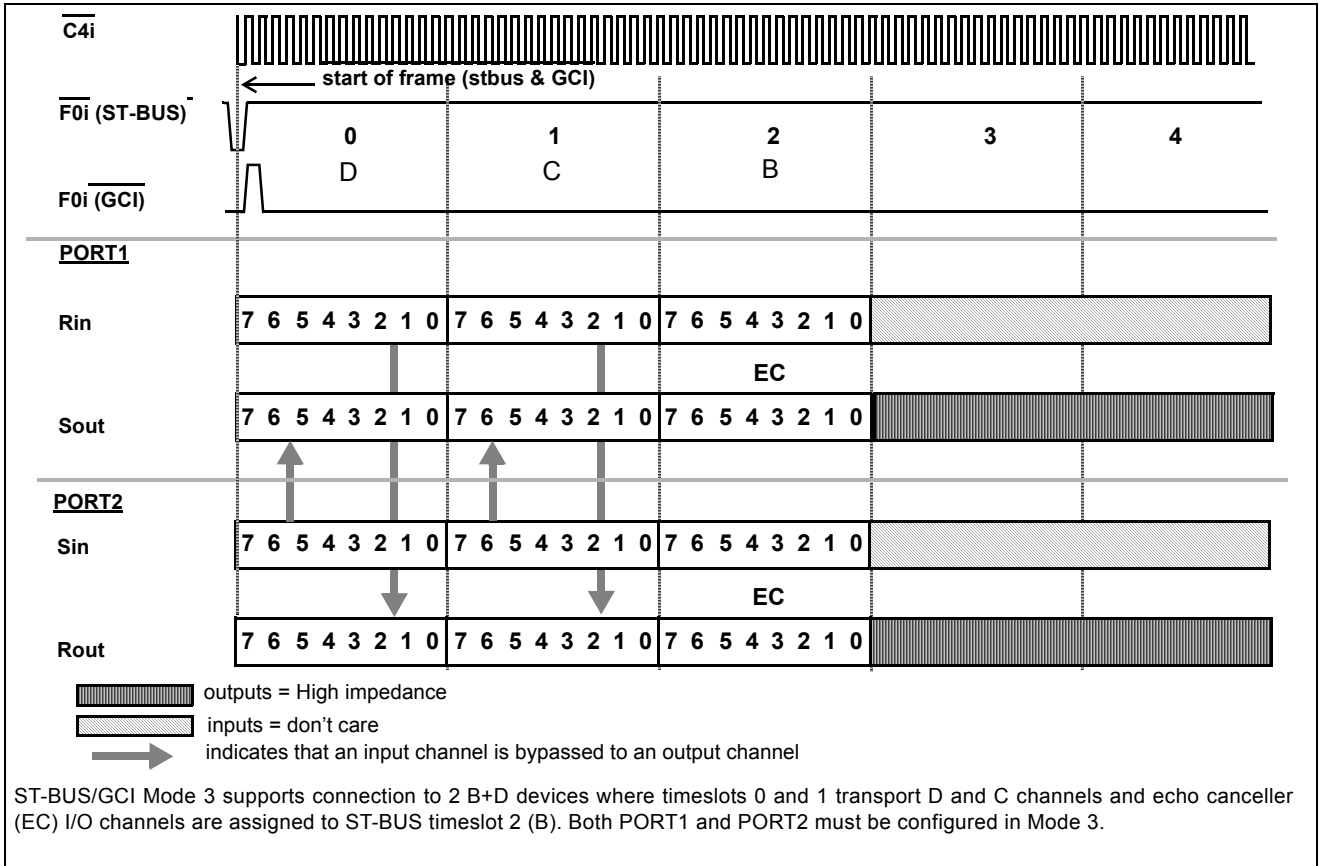

Figure 5 - ST-BUS and GCI 8-Bit Companded PCM I/O with D and C channels (Mode 3)

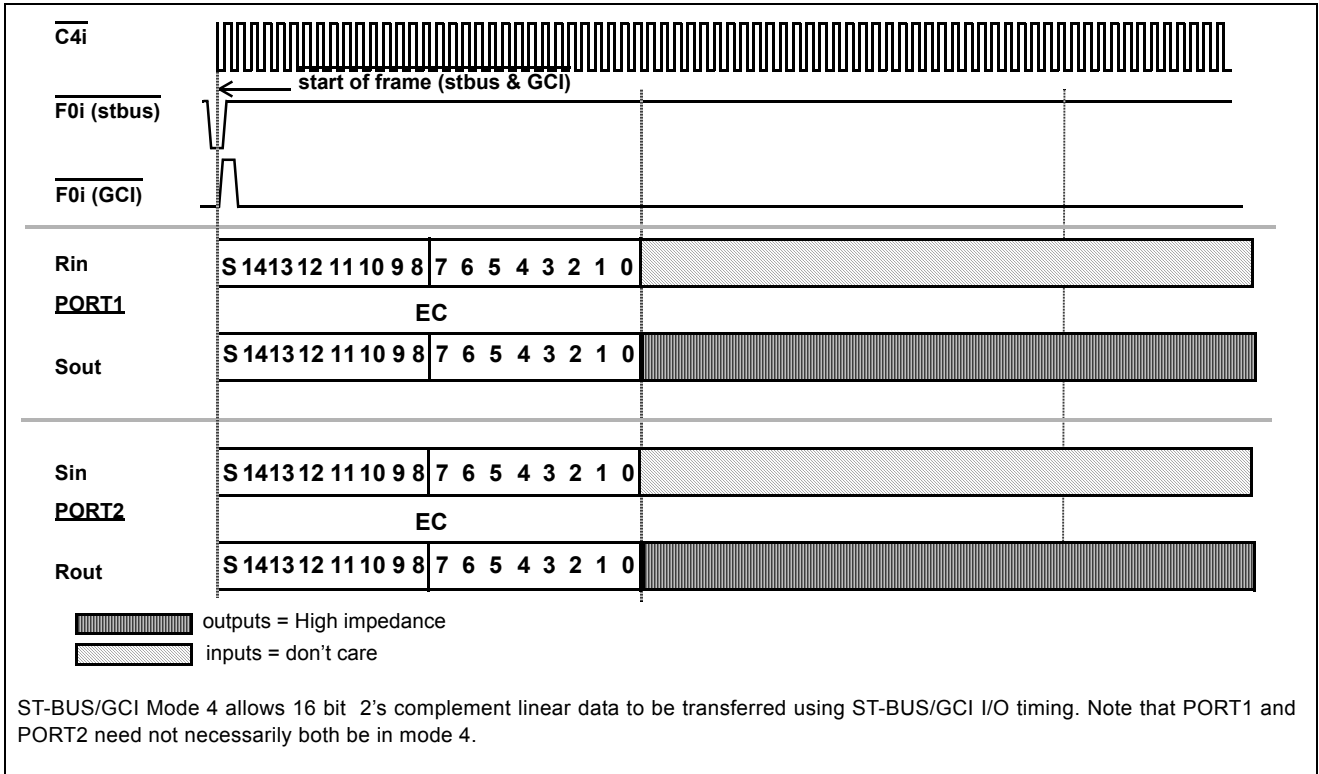

Figure 6 - ST-BUS and GCI 16-Bit 2's Complement Linear PCM I/O (Mode 4)

PORT1 Rin/Sout		ST-BUS/GCI Mode Selection	PORT2 Sin/Rout	
Enable Pins			Enable Pins	
MD1	ENA1		MD2	ENA2
0	0	Mode 1. 8 bit companded PCM I/O on timeslot 0	0	0
0	1	Mode 2. 8 bit companded PCM I/O on timeslot 2.	0	1
1	0	Mode 3. 8 bit companded PCM I/O on timeslot 2. Includes D & C channel bypass in timeslots 0 & 1.	1	0
1	1	Mode 4. 16-bit 2's complement linear PCM I/O on timeslots 0 & 1.	1	1

Table 3 - ST-BUS & GCI Mode Select

3.2 SSI Operation

The SSI PCM interface consists of data input pins (Rin, Sin), data output pins (Sout, Rout), a variable rate bit clock (BCLK), and two enable pins (ENA1, ENA2) to provide strobes for data transfers. The active high enable may be either 8 or 16 BCLK cycles in duration. Automatic detection of the data type (8 bit companded or 16-bit 2's complement linear) is accomplished internally. The data type cannot change dynamically from one frame to the next.

In SSI operation, the frame boundary is determined by the rising edge of the ENA1 enable strobe (see Figure 7). The other enable strobe (ENA2) is used for parsing input/output data and it must pulse within 125 microseconds of the rising edge of ENA1.

In SSI operation, the enable strobes may be a mixed combination of 8 or 16 BCLK cycles allowing the flexibility to mix 2's complement linear data on one port (e.g., Rin/Sout) with companded data on the other port (e.g., Sin/Rout).

Enable Strobe Pin	Designated PCM I/O Port
ENA1	Line Side Echo Path (PORT 1)
ENA2	Acoustic Side Echo Path (PORT 2)

Table 4 - SSI Enable Strobe Pins

3.3 PCM Law and Format Control (LAW, FORMAT)

The PCM companding/coding law used by the ZL38002 is controlled through the LAW and FORMAT pins. ITU-T G.711 companding curves for m-Law and A-Law are selected by the LAW pin. PCM coding ITU-T G.711 and Sign-Magnitude are selected by the FORMAT pin. See Table 4.

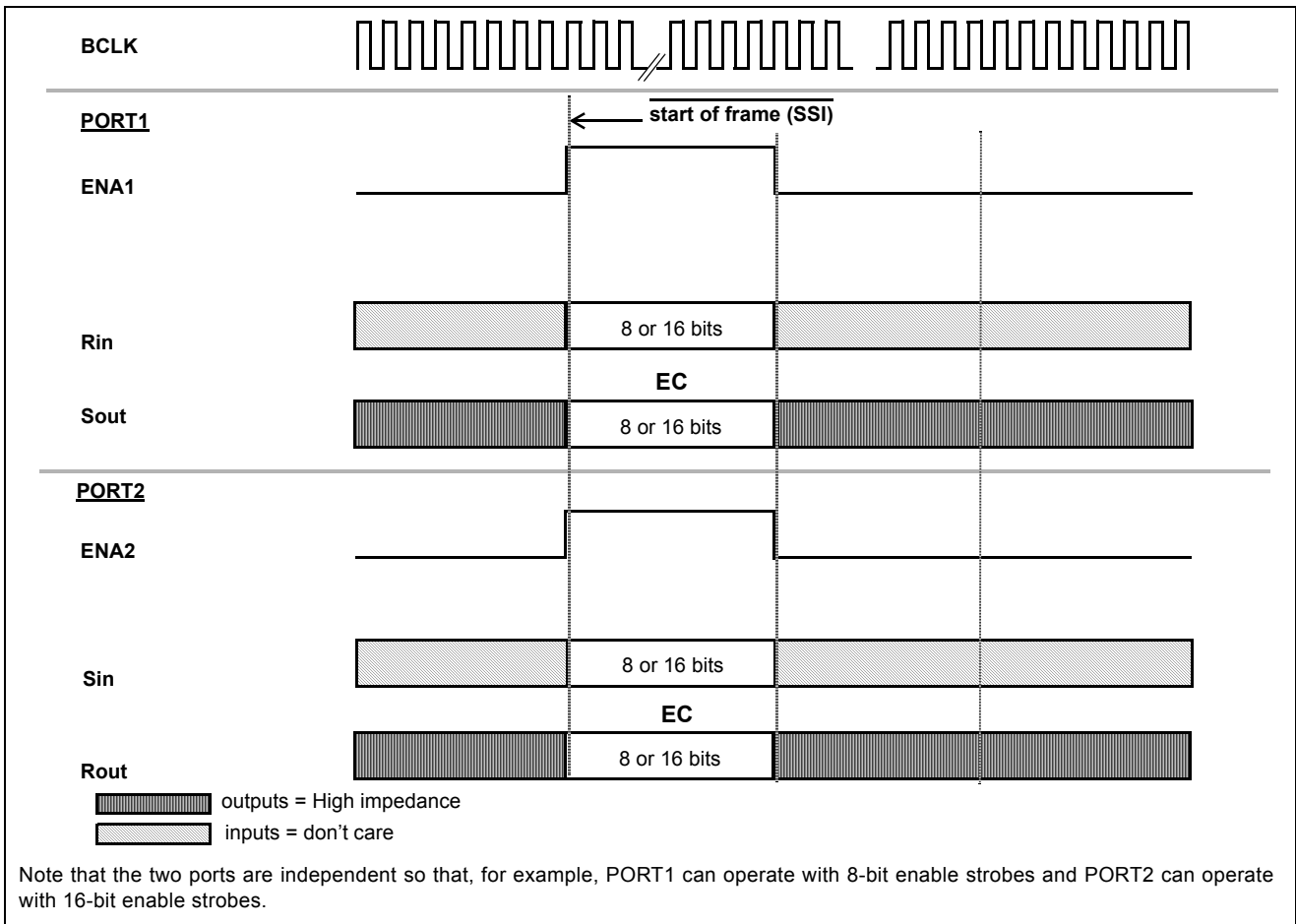

Figure 7 - SSI Operations

PCM Code	Sign-Magnitude	ITU-T (G.711)	
	FORMAT=0	FORMAT=1	
	μ /A-LAW LAW = 0 or 1	μ -LAW LAW = 0	A-LAW LAW = 1
+ Full Scale	1111 1111	1000 0000	1010 1010
+ Zero	1000 0000	1111 1111	1101 0101
- Zero	0000 0000	0111 1111	0101 0101
- Full Scale	0111 1111	0000 0000	0010 1010

Table 5 - Companded PCM

3.4 Linear PCM

The 16-bit 2's complement PCM linear coding permits a dynamic range beyond that which is specified in ITU-T G.711 for companded PCM. The echo-cancellation algorithm will accept 16-bits 2's complement linear code which gives a maximum signal level of +15 dBm0.

3.5 Bit Clock (BCLK/ $\overline{C4i}$)

The BCLK/ $\overline{C4i}$ pin is used to clock the PCM data for GCI and ST-BUS ($\overline{C4i}$) interfaces, as well as for the SSI (BCLK) interface.

In SSI operation, the bit rate is determined by the BCLK frequency. This input must contain either eight or sixteen clock cycles within the valid enable strobe window. BCLK may be any rate between 128 KHz to 4.096 MHz and can be discontinuous outside of the enable strobe windows defined by ENA1, ENA2 pins. Incoming PCM data (Rin, Sin) are sampled on the falling edge of BCLK while outgoing PCM data (Sout, Rout) are clocked out on the rising edge of BCLK. See Figure 13.

In ST-BUS and GCI operation, connect the system $\overline{C4}$ (4.096 MHz) clock to the $\overline{C4i}$ pin.

3.6 Master Clock (MCLK)

A nominal 20 MHz, continuously-running master clock (MCLK) is required. MCLK may be asynchronous with the 8 KHz frame.

4.0 Microport

The serial microport provides access to all ZL38002 internal read and write registers, plus write-only access to the bootloadable program RAM (see next section for bootload description). This microport is compatible with Intel MCS-51 (mode 0), Motorola SPI (CPOL=0, CPHA=0) and National Semiconductor Microwire specifications. The microport consists of a transmit/receive data pin (DATA1), a receive data pin (DATA2), a chip select pin (\overline{CS}) and a synchronous data clock pin (SCLK).

The ZL38002 automatically adjusts its internal timing and pin configuration to conform to Intel or Motorola/National specifications. The microport dynamically senses the state of the SCLK pin each time the \overline{CS} pin becomes active (i.e., high to low transition). If the SCLK pin is high during a \overline{CS} activation, then the Intel mode 0 timing is assumed. In this case the DATA1 pin is defined as a bi-directional (transmit/receive) serial port and DATA2 is internally disconnected. If SCLK is low during a \overline{CS} activation, then Motorola/National timing is assumed and DATA1 is defined as the data transmit pin while DATA2 becomes the data receive pin. The ZL38002 supports Motorola half-

duplex processor mode (CPOL=0 and CPHA=0). This means that during a write to the ZL38002, via a Motorola processor, output data from the DATA1 pin is disregarded. This also means that input data on the DATA2 pin is ignored by the ZL38002 during a valid read by the Motorola processor.

All data transfers through the microport are two bytes long. This requires the transmission of a Command/Address byte followed by the data byte to be written to or read from the addressed register. \overline{CS} must remain low for the duration of this two-byte transfer. As shown in Figures 8 and 9, the falling edge of \overline{CS} indicates to the ZL38002 that a microport transfer is about to begin. The first 8 clock cycles of SCLK after the falling edge of \overline{CS} are always used to receive the Command/Address byte from the microcontroller. The Command/Address byte contains information detailing whether the second byte transfer will be a read or a write operation and at what address. The next 8 clock cycles are used to transfer the data byte between the ZL38002 and the microcontroller. At the end of the two-byte transfer, \overline{CS} is brought high again to terminate the session. The rising edge of \overline{CS} will tri-state the DATA1 pin. The DATA1 pin will remain tri-stated as long as \overline{CS} is high.

Intel processors utilize Least Significant Bit (LSB) first transmission while Motorola/National processors use Most Significant Bit (MSB) first transmission. The ZL38002 microport automatically accommodates both schemes for normal data bytes. However, to ensure timely decoding of the R/W and address information, the Command/Address byte is defined differently for Intel and Motorola/National operations. Refer to the relative timing diagrams of Figure 6 and Figure 7. Receive data bits are sampled on the rising edge of SCLK while transmit data is clocked out on the falling edge of SCLK. Detailed microport timing is shown in Figure 13 and Figure 14.

5.0 Bootload Process and Execution from RAM

A bootloadable program RAM (BRAM) is available on the ZL38002 to support factory-issued software upgrades to the built-in algorithm. To make use of this bootload feature, users must include 4096 X 8 bits of memory in their microcontroller system (i.e., external to the ZL38002), from which the ZL38002 can be bootloaded. Registers and program data are loaded into the ZL38002 in the same fashion via the serial microport. Both employ the same command / address / data byte specification described in the previous section on serial microport. Either intel or motorola mode may be transparently used for bootloading. There are also two registers relevant to bootloading (BRC=control and SIG=signature, see Register Summary). The effect of these register values on device operation is summarized in Table 5.

Bootload mode is entered and exited by writing to the bootload bit in the Bootload RAM Control (BRC) register at address 3fh (see Register Summary). During bootload mode, any serial microport "write" (R/W command bit =0) to an address other than that of the BRC register will contribute to filling the program BRAM. Call these transactions "BRAM-fill" writes. Although a command/address byte must still precede each data byte (as described for the serial microport), the values of the address fields for these "BRAM-fill" writes are ignored (except for the value 3fh, which designates the BRC register.) Instead, addresses are internally generated by the ZL38002 for each "BRAM-fill" write. Address generation for "BRAM-fill" writes resumes where it left off following any read transaction while bootload mode is enabled. The first 4096 "BRAM-fill" writes while bootload is enabled will load the memory, filling the BRAM and ignoring further writes. Before bootload *mode is disabled*, it is recommended that users then read back the value from the signature register (SIG) and compare with the one supplied by the factory along with the code. Equality verifies that the correct data has been loaded. The signature calculation uses an 8-bit MISR which only incorporates input from "BRAM-fill" writes. Resetting the bootload bit (C_2) in the BRC register to 0 (see Register Summary) exits bootload mode, resetting the signature (SIG) register and internal address generator for the next bootload. A hardware reset ($\overline{RESET}=0$) similarly returns the ZL38002 to the ready state for the start of a bootload.

FUNCTIONAL DESCRIPTION FOR USING THE BOOTABLE RAM			
BOOTLOAD MODE - Microport Access is to bootload RAM (BRAM)			
BRC Register Bits C ₃ C ₂ C ₁ C ₀ X 1 0 0	R/ \overline{W}	Address	Data
	\overline{W}	3fh (= 1 1 1 1 1 b)	Writes "data" to BRC reg. - Bootload frozen; BRAM contents are NOT affected.
	\overline{W}	other than 3fh	Writes "data" to next byte in BRAM (bootloading.)
	R	1 x x x x b	Reads back "data" = BRC reg value. - Bootload frozen; BRAM contents are NOT affected.
	R	0 x x x x b	Reads back "data" = SIG reg value. - Bootload frozen; BRAM contents are NOT affected.
NON-BOOTLOAD MODE - Microport Access is to device registers (DREGs)			
BRC Register Bits C ₃ C ₂ C ₁ C ₀ X 0 0 0	R/ \overline{W}	Address	Data
	\overline{W}	any (= a ₅ a ₄ a ₃ a ₂ a ₁ a ₀ b)	Writes "data" to corresponding DREG.
	R	any (= a ₅ a ₄ a ₃ a ₂ a ₁ a ₀ b)	Reads back "data" = corresponding DREG value.
PROGRAM EXECUTION MODES			
C ₃ C ₂ C ₁ C ₀ 0 0 0 0	Execute program in ROM, bootload mode disabled. - BRAM address counter reset to initial (ready) state. - SIG register reseeded to initial (ready) state		
C ₃ C ₂ C ₁ C ₀ 0 1 0 0	Execute program in ROM, while bootloading the RAM. - BRAM address counter increments on microport writes (except to 3fh) - SIG register recalculates signature on microport writes (except to 3fh)		
C ₃ C ₂ C ₁ C ₀ 1 0 0 0	Execute program in RAM, bootload mode disabled. - BRAM address counter reset to initial (ready) state. - SIG register reseeded to initial (ready) state		
C ₃ C ₂ C ₁ C ₀ 1 1 0 0	- INVALID -		

Table 6 - Bootload RAM Control (BRC) Register States

Note: bits C₁ C₀ are reserved, and must be set to zero.

To begin execution from the RAM once the program has been loaded, the bootload mode must be disabled (BOOT bit, $C_2=0$) and execution from RAM enabled (RAM_ROMb bit, $C_3=1$) by setting the appropriate bits in the BRC register. During the bootload process, however, ROM program execution (RAM_ROMb bit, $C_3=0$) should be selected. See Table 5 for the effect of the BRC register settings on Microport accesses and on program execution.

Following program loading and enabling of execution from RAM, it is recommended that the user set the software reset bit in the Main Control (MC) register, to ensure that the device updates the default register values to those of the new program in RAM. Note: it is important to use a software reset rather than a hardware (RESET=0) reset, as the latter will return the device to its default settings (which includes execution from program ROM instead of RAM.)

To verify which code revision is currently running, users can access the Firmware Revision Code (FRC) register (see Register Summary). This register reflects the identity code (revision number) of the last program to run register initialization (which follows a software or hardware reset.)

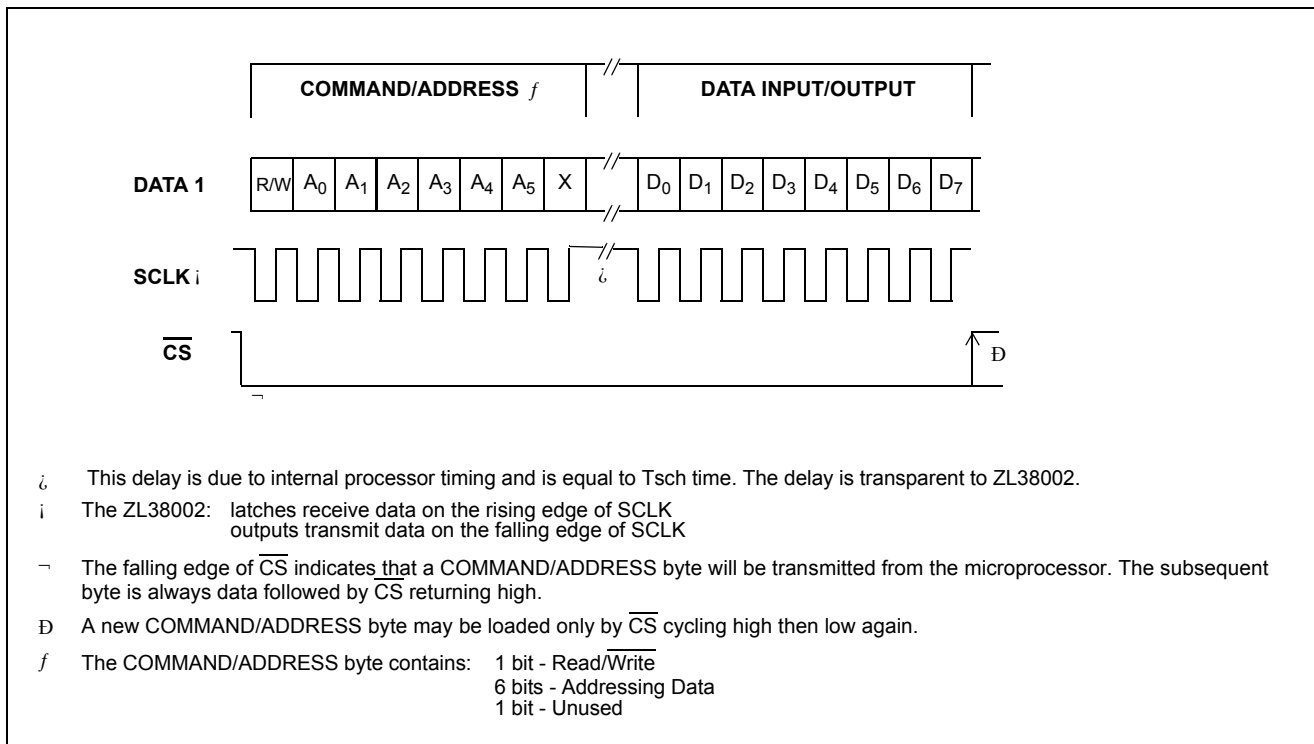

Figure 8 - Serial Microport Timing for Intel Mode 0

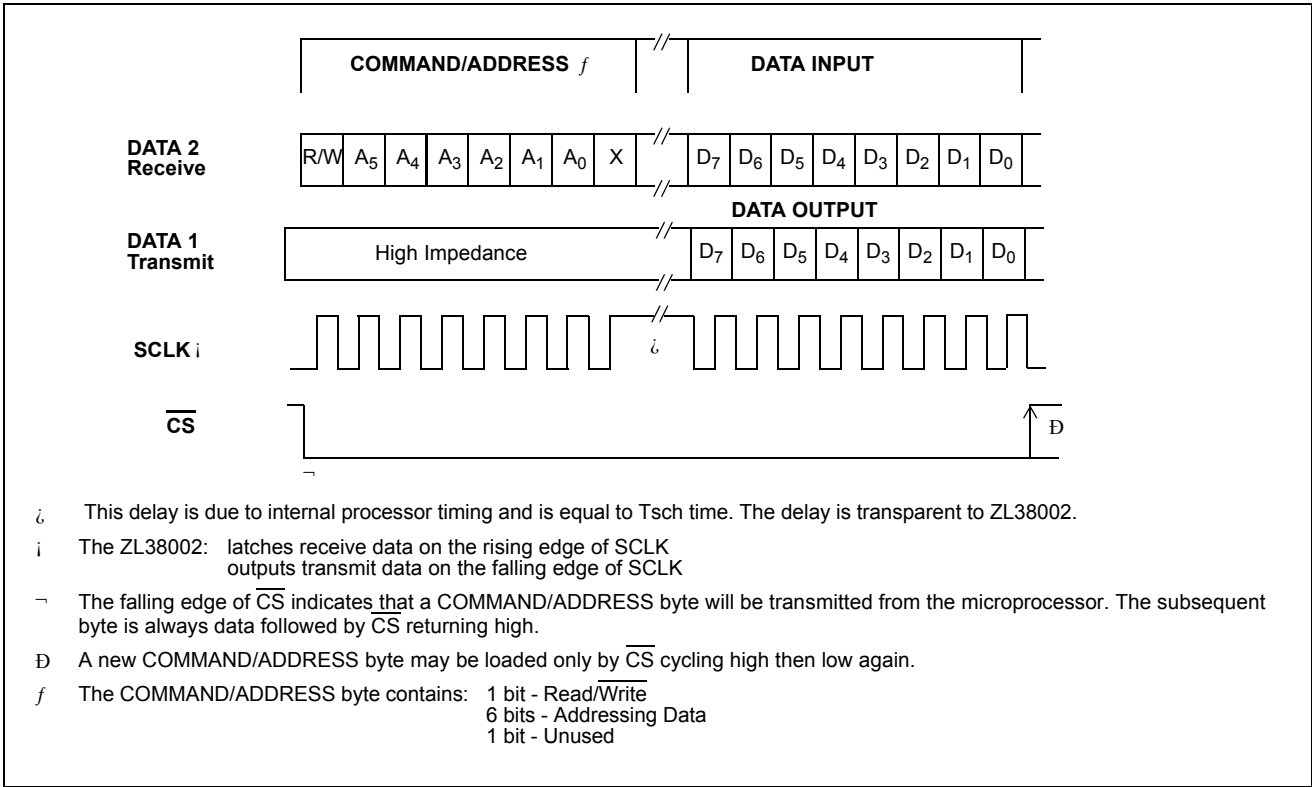

Figure 9 - Serial Microport Timing for Motorola Mode 00 or National Microwire

6.0 Register Summary

Any register not described in the following section should be labels reserved for internal use.

Address	CPU Access	Page	Reset Value	Description
00 _H	R/W	0	00 _H	Main Control Register 1 (MCR1)
01 _H	R/W	0	00 _H	Main Control Register 2 (MCR2)
02 _H	Read	0		Status Register (SR)
03 _H	R/W	0	00 _H	DC Offset Register
04 _H	R/W	0	A1 _H	High Pass Filter Constant Register (FLTSH)
05 _H	R/W	0	08 _H	Mu Constant
07 _H	Read	0	A6 _H	Bootload RAM Signature Register (SIG)
08 _H	R/W	0	80 _H	Slow Adaptation Threshold Register 1 (SATR1)
09 _H	R/W	0	04 _H	Slow Adaptation Threshold Register 2 (SATR2)
12 _H	R/W	0	00 _H	Automatic Sout Gain Reduction (SoutGR)
1C _H	R/W	0	88 _H	Customer Gain Control Register 1 (CGCR1)
1D _H	R/W	0	08 _H	Customer Gain Control Register 2 (CGCR2)
20 _H	R/W	0	6D _H	Receive Gain Control Register (RGCR)
21 _H	R/W	0	00 _H	Acoustic Echo Canceller Control Register (AECGR)
22 _H	Read	0	00 _H	Acoustic Echo Canceller Status Register 1 (ARCSR1)
23 _H	Read	0	00 _H	Acoustic Echo Canceller Status Register 2 (AECSR2)
24 _H	R/W	0	80 _H	Acoustic LMS Filter Length Register 1 (ALMSFR1)
25 _H	R/W	0	3E _H	Acoustic LMS Filter Length Register 2 (ALMSFR2)
26 _H	R/W	0	3D _H	Decay Step Size Control Register (DSSCR)
27 _H	R/W	0	06 _H	Decay Step Number Register (DSNR)
28 _H	R/W	0	96 _H	Near-End Speech Detection Threshold 1 (NESDT1)
29 _H	R/W	0	04 _H	Near-End Speech Detection Threshold 2 (NESDT2)
30 _H	R/W	0	80 _H	Double-Talk Hand-Over Time 1 (DTHOT1)
31 _H	R/W	0	21 _H	Double-Talk Hand-Over Time 2 (DTHOT2)
32 _H	R/W	0	2A _H	Automatic Rout Gain Reduction Register (RoutGR)
34 _H	R/W	0	AA _H	NLP Threshold Register
35 _H	R/W	0	01 _H	
36 _H	Read	0	00 _H	Send (Sin) Peak Detect Register 1 (SPDR1)
37 _H	Read	0	00 _H	Send (Sin) Peak Detect Register 2 (SPDR2)
38 _H	Read	0	00 _H	Send Error Peak Detect Register 1 (SEPDR1)
39 _H	Read	0	00 _H	Send Error Peak Detect Register 2 (SEPDR2)

Table 7 - Address Map

Address	CPU Access	Page	Reset Value	Description
3A _H	Read	0	00 _H	Receive (Rout) Peak Detect Register 1 (RPDR1) Receive (Rout) Peak Detect Register 2 (RPDR2)
3B _H	Read	0	00 _H	
3C _H	Read	0	00 _H	Adaptation Speed Register 1 (ASR1) Adaptation Speed Register 2 (ASR2)
3D _H	Read	0	10 _H	
3F _H	R/W	0/1/2/3	08 _H	BRC Bootload RAM Control Register (BRCR)
1A _H	Read	1	00 _H	Noise Level R Path Register 1 (NLRPR1) Noise Level R Path Register 2 (NLRPR2)
1B _H	Read	1	00 _H	
3A _H	Read	1	00 _H	Noise Level S Path Register 1 (NLSPR1) Noise Level S Path Register 2 (NLSPR2)
3B _H	Read	1	00 _H	
1C _H	R/W	2	00 _H	AGC Gain Register 1 (AGCGR1) AGC Gain Register 2 (AGCGR2)
1D _H	R/W	2	08 _H	
15 _H	R/W	3	20 _H	Noise Threshold for Noise Reduction Register (NRTH)
17 _H	R/W	3	20 _H	Minimum Noise Reduction Level Register(Beta)

Table 7 - Address Map (continued)

7.0 Register Definitions

Read/Write Page 0, Address: 00 _H Reset Value: 00 _H							
7	6	5	4	3	2	1	0
LIMIT	MUTE_R	MUTE_S	BYPASS	NB-	AGC-	AH-	RESET
Bit	Name	Description					
7	LIMIT	When high, Rin and Sin signals are limited to 0.25 in amplitude. When low, no limit is imposed on the inputs.					
6	MUTE_R	When high, the Rin path is muted to quiet code (after the NLP) and when low the Rin path is not muted.					
5	MUTE_S	When high, the Sin path is muted to quiet code (after the NLP) and when low the Sin path is not muted.					
4	BYPASS	When high, the Send and Receive paths are transparently by-passed from input to output and when low the Send and Receive paths are not bypassed.					
3	NB-	When high, Narrowband signal detectors in Rin and Sin paths are disabled and when low the signal detectors are enabled.					
2	AGC-	When high, AGC is disabled and when low AGC is enabled.					
1	AH-	When high, the Howling detector is disabled and when low the Howling detector is enabled.					
0	RESET	When high, the power initialization routine is executed presetting all registers to default values. This bit automatically clears itself to '0' when reset is complete.					

Register Table 1 - Main Control Register 1 (MC1)

Read/Write Address: 01 _H Reset Value: 00 _H							
7	6	5	4	3	2	1	0
SHFT	Reserved	Reserved	NRdis	NSUP3	NSUP2	NSUP1	NSUP0
Bit	Name	Description					
7	SHFT	When high and in 16-bit linear mode, this bit enables shift right by 2 on inputs Sin, Rin, and shift left by 2 on outputs Sout, Rout, for codec. If not in 16-bit linear mode for both I/O ports , this bit is ignored. When low, =default, no shift.					
6	Reserved	Reserved: Must be set to low					
5	Reserved	Reserved: Must be set to low					

Register Table 2 - Main Control Register 2 (MC2)

Read/Write Address: 01 _H Reset Value: 00 _H							
7	6	5	4	3	2	1	0
SHFT	Reserved	Reserved	NRdis	NSUP3	NSUP2	NSUP1	NSUP0
Bit	Name	Description					
4	NRDIS	When high, noise reduction is disabled. When low, noise reduction is enabled.					
3-0	NSUP	Noise Suppression Threshold - Any value below this threshold in the send path will be suppressed (reset)					

Register Table 2 - Main Control Register 2 (MC2)

Read/Write Page 0, Address: 02 _H Reset Value: 00 _H							
7	6	5	4	3	2	1	0
Reserved	Reserved	HFLAG	Reserved	Reserved	Reserved	NB	NBR
Bit	Name	Description					
7-6	Reserved	Reserved: Must be set to low					
5	HFLAG	False howling detect bit.'1' indicates 'false howling' detected (music or sinusoidal match).'0' indicates no 'false howling', i.e. howling is not ruled out (by any matches to music or speech). The final howling decision is in bit 5 of ASR (HWLNG).					
4-2	Reserved	Reserved: Must be set to low					
1	NB	This bit indicates a LOGICAL-OR of status bits NBR + NBS (from ASR register).					
0	NBR	When high, a narrowband signal has been detected in the Receive (Rin/Rout) path.					

Register Table 3 - Acoustic Echo Canceller Status Register

Read/Write Page 0, Address: 03 _H Reset Value: 60 _H							
7	6	5	4	3	2	1	0
Reserved	Reserved	Reserved	DC4	DC3	DC2	DC1	DC0
Bit	Name	Description					
7-5	Reserved	Reserved: Must be set to low					
4-0	DC4-DC0	DC offset value in mute condition.					

Register Table 4 - DC Offset Register

Read/Write Page 0, Address: 04 _H Reset Value: A1 _H							
7	6	5	4	3	2	1	0
FR2	FR1	FR0	FS4	FS3	FS2	FS1	FS0
Bit	Name	Description					
7-5	F _{R2} -F _{R0}	These four bits control the cut-off frequency of HPF at Rin.					
4-0	F _{S4} -F _{S0}	These four bits control the cut-off frequency of HPF at Sin.					

3 dB frequency and bit 0-4 for Sin

00: 2 KHz; 08: 2.65 Hz; 10: 3 KHz; 18: 3.6 Hz
 01: 820 Hz; 09: 1.1 KHz; 11: 1.2 KHz; 19: 1.6 KH
 02: 350 Hz; 0A: 450 Hz; 12: 580 Hz; 1A: 700 Hz
 03: 160 Hz; 0B: 200 Hz; 13: 250 Hz; 1B: 300 Hz
 04: 80 Hz; 0C: 100 Hz; 14: 125 Hz; 1C: 150 Hz
 05: 40 Hz; 0D: 50 Hz; 15: 60 Hz; 1D: 70 Hz
 06: 20 Hz; 0E: 25 Hz; 16: 30 Hz; 1E: 38 Hz
 07: 10 Hz; 0F: 14 Hz; 17: 15 Hz; 1F: 18 Hz

3dB frequency and bit 5-7 for Rin

0: 2 KHz; 1: 820 Hz; 2: 350 Hz; 3: 160 Hz; 4: 80 Hz; 5: 40 Hz; 6: 20 Hz; 7: 10 Hz

Register Table 5 - High Pass Filter Constant Register (FLTSH)

Read/Write Page 0, Address: 05 _H Reset Value: 08 _H							
7	6	5	4	3	2	1	0
RESV	RESV	MU ₅	MU ₄	MU ₃	MU ₂	MU ₁	MU ₀
Bit	Name	Description					
7-0	MU5-0	This register allows the user to program control the adaptation speed. This register allows a maximum value of 3Fh. The default value is 08h corresponding to decimal value of 2.0. Decimal value of 1.0 is 04h. Lower values correspond to slower adaptation speed. Reserved. Write '0'.					

Register Table 6 - Mu Constant Register

Read/Write Page 0, Address: 07 _H Reset Value: FF _H							
7	6	5	4	3	2	1	0
SIG7	SIG6	SIG5	SIG4	SIG3	SIG2	SIG1	SIG0
Bit	Name	Description					
7-0	SIG7-0	This register provides the signature of the bootloaded data to verify error-free delivery into the device. Note: this register is only accessible if BOOT bit is high (bootload mode enabled) in the above BRC register. While bootload is disabled, the register value is held constant at its reset seed value of FF _H .					

Register Table 7 - Bootload RAM Signature Register (SIG)

Read/Write Page 0, Address: 09 _H Reset Value: 04 _H							
7	6	5	4	3	2	1	0
SAT15	SAT14	SAT13	SAT12	SAT11	SAT10	SAT9	SAT8
Read/Write Page 0, Address: 08 _H Reset Value: 80 _H							
7	6	5	4	3	2	1	0
SAT7	SAT6	SAT5	SAT4	SAT3	SAT2	SAT1	SAT0
Bit	Name	Description					
15-0	SAT15-SAT0	Threshold for deciding low adaptation speed. 8000h = 1.0.					

Register Table 8 - Slow Adaptation Threshold Registers (SATR1) & (SATR2)

Read/Write Page 0, Address: 12 _H Reset Value: 00 _H							
7	6	5	4	3	2	1	0
Reserved	Reserved	Reserved	Reserved	Reserved	Reserved	Reserved	SoutGR
Bit	Name	Description					
7 - 1	Reserved	Reserved: Must be set to low					
0	SoutGR	This bit will provide an automatic signal reduction on Sout by 12 dB (far-end speaker) when double talk is present with this bit set to 1.					

Register Table 9 - Sout Gain Reduction (SoutGR)

Read/Write Page 0, Address: 1D _H Reset Value: 08 _H							
15	14	13	12	11	10	9	8
Reserved	Reserved	Reserved	Reserved	XRAMGain3	XRAMGain2	XRAMGain1	XRAMGain0
Read/Write Page 0, Address: 1C _H Reset Value: 88 _H							
7	6	5	4	3	2	1	0
SoutGain3	SoutGain2	SoutGain1	SoutGain0	SinGain3	SinGain3	SinGain3	SinGain3
Bit	Name	Description					
15-12	Reserved	Reserved: Must be set to low					
11-8	XRAMGain3-0	Gain control for ROUT to Xram, range from -24 dB to 21 dB. (1111=+21dB, 0000=-24 dB)					
7-4	SoutGain3-0	Gain control for SOUT, range from -24 dB to 21 dB. (1111=+21dB, 0000=-24 dB)					
3-0	SinGain3-0	Gain control for SIN, range from -24 dB to 21 dB. (1111=+21dB, 0000=-24 dB)					

Register Table 10 - Customer Gain Control Registers (CGCR1) & (CGCR2)

Read/Write Page 0, Address: 20H
Reset Value: 00H

7	6	5	4	3	2	1	0
Reserved	Reserved	Reserved	Reserved	G3	G2	G1	G0

Bit	Name	Description
7-4	Reserved	Reserved: Must be set to low
3	G3	User Gain Control on Rin/Rout path. (Tolerance of gain values: +/- 0.15 dB)
2	G2	
1	G1	
0	G0	

Gain Code: G4-G0	Gain(dB) data sheet	Gain(dB) actual
00h	-24	-24.08
01h	-21	-21.31
02h	-18	-18.06
03h	-15	-14.91
04h	-12	-12.04
05h	-9	-9.08
06h	-6	-6.02
07h	-3	-3.06
08h	+0	+0
09h	+3	+3.01
0Ah	+6	+5.99
0Bh	+9	+9.01
0Ch	+12	+12.01
0Dh	+15	+15.03
0Eh	+18	+18.03
0Fh	+21	+21.05

Register Table 11 - Receive Gain Control (RCGR)

Read/Write Page 0, Address: 21H Reset Value: 00H							
7	6	5	4	3	2	1	0
Reserved	ASC-	NLP-	INJ-	HPF-	HCLR	ADAPT-	ECBY
Bit	Name	Description					
7	Reserved	Reserved: Must be set to low					
6	ASC-	When high, internal adaptation speed control is disabled. When low, internal adaptation speed control is enabled.					
5	NLP-	When high, the non-linear processor in the Sin/Sout path is disabled. When low, the non-linear processor in the Sin/Sout path is enabled.					
4	NJ-	When high, the noise filtering process is disabled in the NLP. When low, the noise filtering process is enabled in the NLP.					
3	HPF-	When high, the offset nulling filter is bypassed in the Sin/Sout path. When low, the offset nulling filter in the Sin/Sout path is active and will remove DC offset on the Rin input signal.					
2	HCLR	When high, the H register in the adaptive filter is cleared. When low, the H register is not cleared					
1	ADAPT-	When high, echo canceller adaptation is disabled. When low, the echo canceller adapts to the echo path characteristics.					
0	ECBY	When high, the echo estimate from the adaptive filter is not subtracted from the Send path. When low, the echo estimate is subtracted from the Send path.					

Register Table 12 - Acoustic Echo Canceller Control Register (AECCR)

Read Page 0, Address: 22H Reset Value: 00H							
7	6	5	4	3	2	1	0
ACMUTH	ACMUND	HWLNG	NLPUH	NLPDCW	DT	NB	NBS
Bit	Name	Description					
7	ACMUTH	Energy comparison for mu value.'1' indicates enough echo suppression.					
6	ACMUND	When low, indicates that the Rin/Rout Receive path has no active signal.					
5	HWLNG	When high indicates that howling is occurring in the loop. A related 'false howling' bit (HFLAG) in bit 5 of LSR is created as part of the howling-detect decision making.					
4	NLPUH	Peak comparison with NLP up threshold.'1' indicates not enough echo suppression.					
3	NLPDC	When high indicates that the NLP is activated.					
2	DT	When high, double-talk is present.					
1	NB	This bit indicates a LOGICAL-OR of status bits NBS + NBR (from LSR register).					
0	NBS	When high, a narrowband signal has been detected in the Send (Sin/Sout) path.					

Register Table 13 - STATUS Acoustic Echo Canceller Status Register (AEC SR1)

Read Page 0, Address: 23H Reset Value: 00H							
7	6	5	4	3	2	1	0
Reserved	Reserved	Reserved	DHCLR	ACMUFL	ACMULOW	ACMUNSP	NLPDCLD
Bit	Name	Description					
7-4	Reserved						
4	DHCLR	Indicate the divergence of adaptation. "1" indicates that strong divergence occurs with error energy is at least double the input signal energy. Reserved (anything written on it will be overwritten by temporary variable in the program).					
3	ACMUFL	Adaptation floor decision. '1' indicates the reference is below the adaptation floor, no adaptation.					
2	Reserved						
1	ACMUNSP	Indicates strong near-end speech.					
0	Reserved						

Register Table 14 - Acoustic Echo Canceller Status register 2 (AEC SR2)

Read/Write Page 0, Address: 25H Reset Value: 3EH							
15	14	13	12	11	10	9	8
L7	L6	L5	L5	L4	L3	L2	L1
Read/Write Page 0, Address: 24H Reset Value: 80H							
7	6	5	4	3	2	1	0
L0	F6	F5	F4	F3	F2	F1	F0
Bit	Name	Description					
6-0	F6-F0	Allows the acoustic LMS filter length to be reduced. The register value is in terms of milliseconds.					
15-7	L7-L0	Maps to Rout limiter value, Limit = 0L ₈ L ₇ L ₆ L ₅ L ₄ L ₃ L ₂ L ₁ L ₀ 00 0000, Range: 040h - 7FC0h, plus 00h point value. Default: 1F40h					

Register Table 15 - Acoustic LMS Filter Length Registers (ALMSFR1) & (ALMSFR2)

Read/Write Page 0, Address: 26H Reset Value: 3DH							
7	6	5	4	3	2	1	0
L4	L3	L2	L1	L0	SSC2	SSC1	SSC0
Bit	Name	Description					
7-3	L4-L0	Sout Limit Value: Stores the variable limit for Sout. The interpretation of these bits is not direct: 00111 maps to default value = 1F40h. Limit level = 0L ₄ L ₃ L ₂ L ₁ L ₀ 11 0100 0000, range: 0340h - 7F40h.					
2-0	SSC2-SSC0	Decay Step Size Control: This register controls the step size (SS) to be used during the exponential decay of MU.					

Register Table 16 - Decay Step Size Control Register (DSSCR)

Read/Write Page 0, Address: 27 _H Reset Value: 06 _H							
7	6	5	4	3	2	1	0
NS7	NS6	NS5	NS4	NS3	NS2	NS1	NS0
Bit	Name	Description					
7-0	NS7-NS0	Decay Step Number: This register defines the number of steps to be used for the decay of MU where each step has a period of SS taps (see SSC ₂₋₀).					

Register Table 17 - Decay Step Number Register (DSNR)

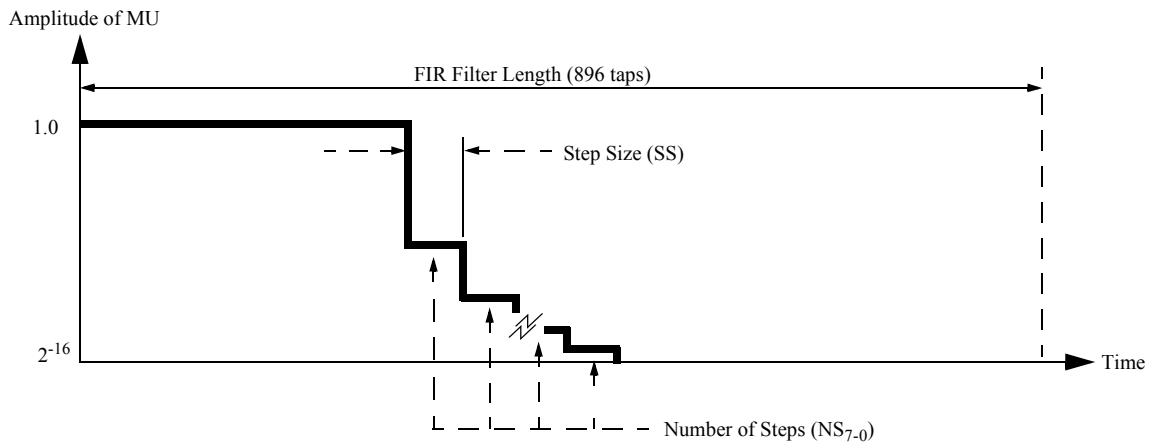

The Exponential Decay registers (Decay Step Number and Decay Step Size) allow the LMS adaptation step-size (MU) to be programmed over the length of the FIR filter. A programmable MU profile allows the performance of the echo canceller to be optimized for specific applications. For example, if the characteristic of the echo response is known to have a roughly exponential decay of the echo impulse response, then the MU profile can be programmed to approximate this expected impulse response thereby improving the convergence characteristics of the adaptive filter. Note that in the following register descriptions, one tap is equivalent to 125 ms.

- SSC₂₋₀ **Decay Step Size Control:** This register controls the step size (SS) to be used during the exponential decay of MU. The decay rate is defined as a decrease of MU by a factor of 2 every SS taps of the FIR filter, where $SS = 4 \times 2^{SSC_{2-0}}$. For example; If SSC₂₋₀ = 4, then MU is reduced by a factor of 2 every 64 taps of the FIR filter. **The default value of SSC₂₋₀ is 05h.**
- L₄₋₀ **Sout Limit Value:** Stores the variable limit for Sout. The interpretation of these bits is not direct: 00111 maps to default value = 1F40h. Limit level = 0L₄L₃L₂ L₁L₀11 0100 0000 , range: 0340h - 7F40h.
- NS₇₋₀ **Decay Step Number:** This register defines the number of steps to be used for the decay of MU where each step has a period of SS taps (see SSC₂₋₀). The start of the exponential decay is defined as:
Filter Length (896) - [Decay Step Number (NS₇₋₀) x Step Size (SS)] where $SS = 4 \times 2^{SSC_{2-0}}$.
For example, if NS₇₋₀=4 and SSC₂₋₀=4, then the exponential decay start value is **896 - [NS₇₋₀ x SS] = 896 - [4 x (4x2⁴)] = 640** taps for a filter length of 896 taps.

Read/Write Page 0, Address: 29_H
Reset Value: 04_H

15	14	13	12	11	10	9	8
MUURAT15	MUURAT14	MUURAT13	MUURAT12	MUURAT11	MUURAT10	MUURAT9	MUURAT8

Read/Write Page 0, Address: 28_H
Reset Value: 96_H

7	6	5	4	3	2	1	0
MUURAT7	MUURAT6	MUURAT5	MUURAT4	MUURAT3	MUURAT2	MUURAT1	MUURAT0

Bit	Name	Description
15-0	MUURAT15- MUURAT0	Threshold for deciding near end speech ($\mu = 0$). 1000h = 1.0.

Register Table 18 - Near-End Speech Detection Threshold Registers (NESDT1) & (NESDT2)

Read/Write Page 0, Address: 31_H
Reset Value: 04_H

15	14	13	12	11	10	9	8
DTH2	DTH1	DTH1	DTHOT12	DTHOT11	DTHOT10	DTHOT9	DTHOT8

Read/Write Page 0, Address: 30_H
Reset Value: 96_H

7	6	5	4	3	2	1	0
DTHOT7	DTHOT6	DTHOT5	DTHOT4	DTHOT3	DTHOT2	DTHOT1	DTHOT0

Bit	Name	Description
13-15	DTH2DTH0	Double Talk Threshold- in 6 dB increments from -30 dB to (0h = -30 dB, 7h = +12 dB)
12-0	DTHOT12-DTHOT0	Double-Talk hand-over time

Register Table 19 - Near-End Speech Detection Threshold Registers (DTHOT1) & (DTHOT2)

Read/Write Page 0, Address: 32_H
Reset Value: 2A_H

7	6	5	4	3	2	1	0
RESERVED	RESERVED	RESERVED	RESERVED	RESERVED	RESERVED	RESERVED	RoutGR

Bit	Name	Description
0	RoutGR	This bit will provide an automatic signal reduction on Rout by 12 db when double talk is present with this bit set to 1.

Figure 10 - Automatic Rout Gain Reduction (RoutGR)

Read/Write Page 01, Address: 35_H
Reset Value: 01_H

15	14	13	12	11	10	9	8
NLPTH15	NLPTH14	NLPTH13	NLPTH12	NLPTH11	NLPTH10	NLPTH9	NLPTH8

Read/Write Page AA, Address: 34_H
Reset Value: AA_H

7	6	5	4	3	2	1	0
NLPTH7	NLPTH6	NLPTH15	NLPTH4	NLPTH3	NLPTH2	NLPTH1	NLPTH0

Bit	Name	Description
15-0	NLPTH15- NLPTH0	This register allows the user to program the level of the Non-Linear Processor Threshold. The 16 bit 2's complement linear value defaults to 1AAh. The maximum value is 7FFFh = 0.9999. Higher value corresponds to higher threshold. The high byte is in Register 2 and the low byte is in Register 1.

Register Table 20 - NLP Threshold Register

Read/Write Page 0, Address: 37_H
Reset Value: 00_H

15	14	13	12	11	10	9	8
SIPD15	SIPD14	SIPD13	SIPD12	SIPD11	SIPD10	SIPD9	SIPD8

Read/Write Page 0, Address: 36_H
Reset Value: 00_H

7	6	5	4	3	2	1	0
SIPD7	SIPD6	SIPD15	SIPD4	SIPD3	SIPD2	SIPD1	SIPD0

Bit	Name	Description
15-0	SIPD15-SIPD0	These peak detector registers allow the user to monitor the send in signal (Sin) peak signal level at reference point S ₁ (see Figure 1). The information is in 16-bit 2's complement linear coded format presented in two 8 bit registers. The high byte is in Register 2 and the low byte is in Register 1.

Register Table 21 - Send (Sin) Peak Detect Registers (SPDR1) & (SPDR2)

Read/Write Page 0, Address: 39_H
Reset Value: 00_H

15	14	13	12	11	10	9	8
SEPD15	SEPD14	SEPD13	SEPD12	SEPD11	SEPD10	SEPD9	SEPD8

Read/Write Page 0, Address: 38_H
Reset Value: 00_H

7	6	5	4	3	2	1	0
SEPD7	SEPD6	SEPD15	SEPD4	SEPD3	SEPD2	SEPD1	SEPD0

Bit	Name	Description
15-0	SEPD15-SEPD0	These peak detector registers allow the user to monitor the error signal peak level in the Send path at reference point S ₂ (see Figure 1). The information is in 16-bit 2's complement linear coded format presented in two 8 bit registers. The high byte is in Register 2 and the low byte is in Register 1.

Register Table 22 - Send Error Peak Detect Registers (SEPDR1) & (SEPDR2)

Read/Write Page 0, Address: 3B _H Reset Value: 00 _H							
15	14	13	12	11	10	9	8
ROPD15	ROPD14	ROPD13	ROPD12	ROPD11	ROPD10	ROPD9	ROPD8
Read/Write Page 0, Address: 3A _H Reset Value: 00 _H							
7	6	5	4	3	2	1	0
ROPD7	ROPD6	ROPD5	ROPD4	ROPD3	ROPD2	ROPD1	ROPD0
Bit	Name	Description					
15-0	ROPD15-ROPD0	These peak detector registers allow the user to monitor the receive out signal (Rout) peak signal level at reference point R1 (see Figure 1). The information is in 16-bit 2's complement linear coded format presented in two 8 bit registers. The high byte is in Register 2 and the low byte is in Register 1.					

Register Table 23 - Receive (Rout) Peak Detect Registers (RPDR1) & (RPDR2)

Read/Write Page 0, Address: 3D _H Reset Value: 10 _H							
15	14	13	12	11	10	9	8
A_AS15	A_AS14	A_AS13	A_AS12	A_AS11	A_AS10	A_AS9	A_AS8
Read/Write Page 0, Address: 3C _H Reset Value: 00 _H							
7	6	5	4	3	2	1	0
A_AS7	A_AS6	A_AS5	A_AS4	A_AS3	A_AS2	A_AS1	A_AS0
Bit	Name	Description					
15-0	A_AS15-0	Actual mu sent to acoustic LMS. This register is where we can feed externally calculated mu value. This register allows the user to program control the adaptation speed. The default value is 1000h corresponding to decimal value of 2.0. The high byte is in Register 2 and the low byte is in Register 1. Smaller values correspond to slower adaptation speed.					

Register Table 24 - Adaptation Speed Registers (ASR1) & (ASR2)

Read/Write Page 0/1/2/3, Address: 3F_H
Reset Value: 00_H

7	6	5	4	3	2	1	0
-	-	-	-	ROM/RAM	BOOT BIT	PAGEH	PAGEL

Bit	Name	Description
7-4	Unused	Must be set to 0
3	RAM/ROM	When high, device executes from RAM. When low, device executes from ROM.
2	BOOT BIT	When high, puts device in bootload mode. When low, bootload is disabled.
1	PAGE H	Controls the register page being accessed by address 00h-3Fh. 00 = page 0 (default), 01 = page 1, 10 = page 2, 11 = page 3
0	PAGE L	

Register Table 25 - BRC Bootload RAM Control Register (BRCR)

Read/Write Page 1, Address: 1B_H
Reset Value: 10_H

15	14	13	12	11	10	9	8
NLVRL15	NLVRL14	NLVRL13	NLVRL12	NLVRL11	NLVRL10	NLVRL9	NLVRL8

Read/Write Page 1, Address: 1A_H
Reset Value: 00_H

7	6	5	4	3	2	1	0
NLVRL7	NLVRL6	NLVRL5	NLVRL4	NLVRL3	NLVRL2	NLVRL1	NLVRL0

Bit	Name	Description
15-0	NLVRL15-0	Estimated noise level in R path.

Register Table 26 - Noise Level Registers R Path (NLRPR1) & (NLRPR2)

Read/Write Page 1, Address: 3B_H
Reset Value: 00_H

15	14	13	12	11	10	9	8
NLVSL15	NLVSL14	NLVSL13	NLVSL12	NLVSL11	NLVSL10	NLVSL9	NLVSL8

Read/Write Page 1, Address: 3A_H
Reset Value: 00_H

7	6	5	4	3	2	1	0
NLVSL7	NLVSL6	NLVSL5	NLVSL4	NLVSL3	NLVSL2	NLVSL1	NLVSL0

Bit	Name	Description
15-0	NLVRL15-0	Estimated noise level in S path.

Register Table 27 - Noise Level S Path Registers (NLSPR1) & (NLSPR2)

Read/Write Page 2, Address: 1D_H
Reset Value: 08_H

15	14	13	12	11	10	9	8
AGCGN15	AGCGN14	AGCGN13	AGCGN12	AGCGN11	AGCGN10	AGCGN9	AGCGN8

Read/Write Page 2, Address: 1C_H
Reset Value: 00_H

7	6	5	4	3	2	1	0
AGCGN7	AGCGN6	AGCGN5	AGCGN4	AGCGN3	AGCGN2	AGCGN1	AGCGN0

Bit	Name	Description
15-0	AGCGN15-0	AGC gain value (1=4000h)

Register Table 28 - AGC Gain Register (AGCGR1) & (AGCGR2)

Read/Write Page 3, Address: 15 _H Reset Value: 20 _H							
7	6	5	4	3	2	1	0
NRTH7	NRTH6	NRTH5	NRTH4	NRTH3	NRTH2	NRTH1	NRTH0
Bit	Name	Description					
7-0	NRTH7-0	This register scales the noise threshold for noise reduction.					

Register Table 29 - Noise Threshold for Noise Reduction Register (NRTH)

Read/Write Page 3, Address: 17 _H Reset Value: 20 _H							
7	6	5	4	3	2	1	0
BETA7	BETA6	BETA5	BETA4	BETA3	BETA2	BETA1	BETA0
Bit	Name	Description					
7-0	BETA7-0	This register sets the minimum noise reduction for each sample.					

Register Table 30 - Noise reduction Register

8.0 Electrical Characteristics

Absolute Maximum Ratings*

	Parameter	Symbol	Min.	Max.	Units
1	Supply Voltage	$V_{DD}-V_{SS}$	-0.5	5.0	V
2	Input Voltage	V_i	$V_{SS}-0.3$	5.5	V
3	Output Voltage Swing	V_o	$V_{SS}-0.3$	5.5	V
4	Continuous Current on any digital pin	$I_{i/o}$		± 20	mA
5	Storage Temperature	T_{ST}	-65	150	°C
6	Package Power Dissipation	P_D		90 (typ)	mW

* Exceeding these values may cause permanent damage. Functional operation under these conditions is not implied.

Recommended Operating Conditions - Voltages are with respect to ground (V_{SS}) unless otherwise stated.

	Characteristics	Sym.	Min.	Typ.	Max.	Units	Test Conditions
1	Supply Voltage	V_{DD}	2.7	3.3	3.6	V	
2	Input High Voltage		1.4		V_{DD}	V	
3	Input Low Voltage		V_{SS}		0.4	V	
4	Operating Temperature	T_A	-40		+85	°C	

Echo Return Limits

	Characteristics	Min.	Typ.	Max.	Units	Test Conditions
1	Acoustic Echo Return			6	dB	Measured from Rout -> Sin (using the Customer Gain Control registers)

DC Electrical Characteristics*- Voltages are with respect to ground (V_{SS}) unless otherwise stated.

	Characteristics	Sym.	Min.	Typ. [‡]	Max.	Units	Conditions/Notes
1	Standby Supply Current:	I_{CC}		3	70	μA	$\overline{RESET} = 0$
	Operating Supply Current:	I_{DD}		20		mA	$\overline{RESET} = 1$, clocks active
2	Input HIGH voltage	V_{IH}	$0.7V_{DD}$			V	
3	Input LOW voltage	V_{IL}			$0.3V_{DD}$	V	
4	Input leakage current	I_{IH}/I_{IL}		0.1	10	μA	$V_{IN}=V_{SS}$ to V_{DD}
5	High level output voltage	V_{OH}	$0.8V_{DD}$			V	$I_{OH}=2.5$ mA
6	Low level output voltage	V_{OL}			0.4V	V	$I_{OL}=5.0$ mA
7	High impedance leakage	I_{OZ}		1	10	μA	$V_{IN}=V_{SS}$ to V_{DD}
8	Output capacitance	C_o		10		pF	
9	Input capacitance	C_i		8		pF	

[‡] Typical figures are at 25°C and are for design aid only: not guaranteed and not subject to production testing.

*DC Electrical Characteristics are over recommended temperature and supply voltage.

AC Electrical Characteristics[†] - Serial Data Interfaces - Voltages are with respect to ground (V_{SS}) unless otherwise stated.

	Characteristics	Sym.	Min.	Typ.	Max.	Units	Test Notes
1	MCLK Frequency	f_{CLK}	19.15		20.5	MHz	
2	BCLK/ $\overline{C4i}$ Clock High	t_{BCH} , t_{C4H}	90			ns	
3	BCLK/ $\overline{C4i}$ Clock Low	t_{BLL} , t_{C4L}	90			ns	
4	BCLK/ $\overline{C4i}$ Period	t_{BCP}	240		7900	ns	
5	SSI Enable Strobe to Data Delay (first bit)	t_{SD}	80			ns	$C_L = 150$ pF
6	SSI Data Output Delay (excluding first bit)	t_{DD}	80			ns	$C_L = 150$ pF
7	SSI Output Active to High Impedance	t_{AHZ}	80			ns	$C_L = 150$ pF
8	SSI Enable Strobe Signal Setup	t_{SSS}	10		t_{BCP} -15	ns	
9	SSI Enable Strobe Signal Hold	t_{SSH}	15		t_{BCP} -10	ns	
10	SSI Data Input Setup	t_{DIS}	10			ns	
11	SSI Data Input Hold	t_{DIH}	15			ns	
12	ST-BUS/GCI $\overline{F0i}$ Setup	t_{F0iS}	20		150	ns	
13	ST-BUS/GCI $\overline{F0i}$ Hold	t_{F0iH}	20		150	ns	
14	ST-BUS/GCI Data Output delay	t_{DSD}	80			ns	$C_L = 150$ pF
15	ST-BUS/GCI Output Active to High Impedance	t_{ASHZ}	80			ns	$C_L = 150$ pF
16	ST-BUS/GCI Data Input Hold time	t_{DSH}	20			ns	
17	ST-BUS/GCI Data Input Setup time	t_{DSS}	20			ns	

[†] Timing is over recommended temperature and power supply voltages.

AC Electrical Characteristics[†] - Microport Timing

	Characteristics	Sym.	Min.	Typ.	Max.	Units	Test Notes
1	Input Data Setup	t_{IDS}	30			ns	
2	Input Data Hold	t_{IDH}	30			ns	
3	Output Data Delay	t_{ODD}			100	ns	$C_L = 150 \text{ pF}$
4	Serial Clock Period	t_{SCP}	500			ns	
5	SCLK Pulse Width High	t_{SCH}	250			ns	
6	SCLK Pulse Width Low	t_{SCL}	250			ns	
7	CS Setup-Intel	t_{CSSI}	200			ns	
8	\overline{CS} Setup-Motorola	t_{CSSM}	100			ns	
9	\overline{CS} Hold	t_{CSH}	100			ns	
10	\overline{CS} to Output High Impedance	t_{OHZ}	100			ns	$C_L = 150 \text{ pF}$

[†] Timing is over recommended temperature range and recommended power supply voltages.

Characteristic	Symbol	CMOS Level	Units
CMOS reference level	V_{CT}	$0.5 \cdot V_{DD}$	V
Input HIGH level	V_H	$0.9 \cdot V_{DD}$	V
Input LOW level	V_L	$0.1 \cdot V_{DD}$	V
Rise/Fall HIGH measurement point	V_{HM}	$0.7 \cdot V_{DD}$	V
Rise/Fall LOW measurement point	V_{LM}	$0.3 \cdot V_{DD}$	V

Table 8 - Reference Level Definition for Timing Measurements

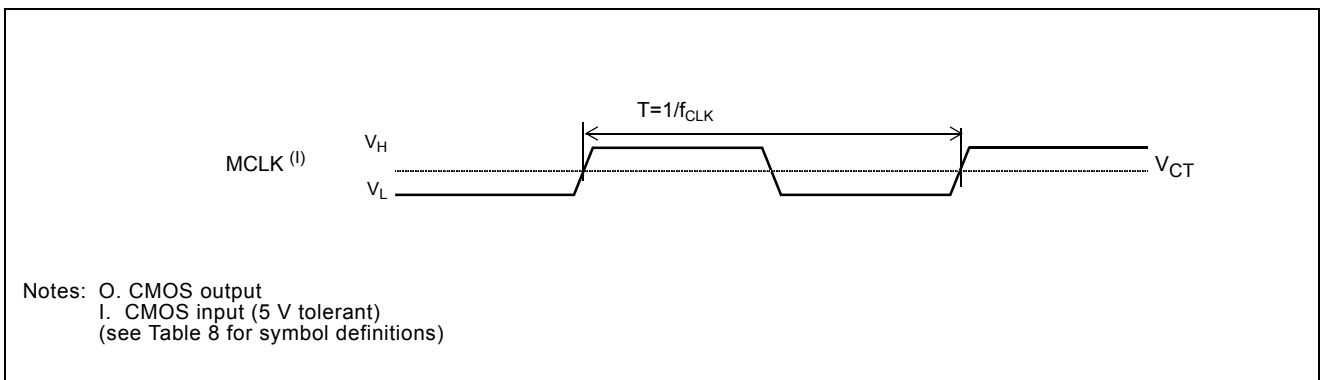

Figure 11 - Master Clock - MCLK

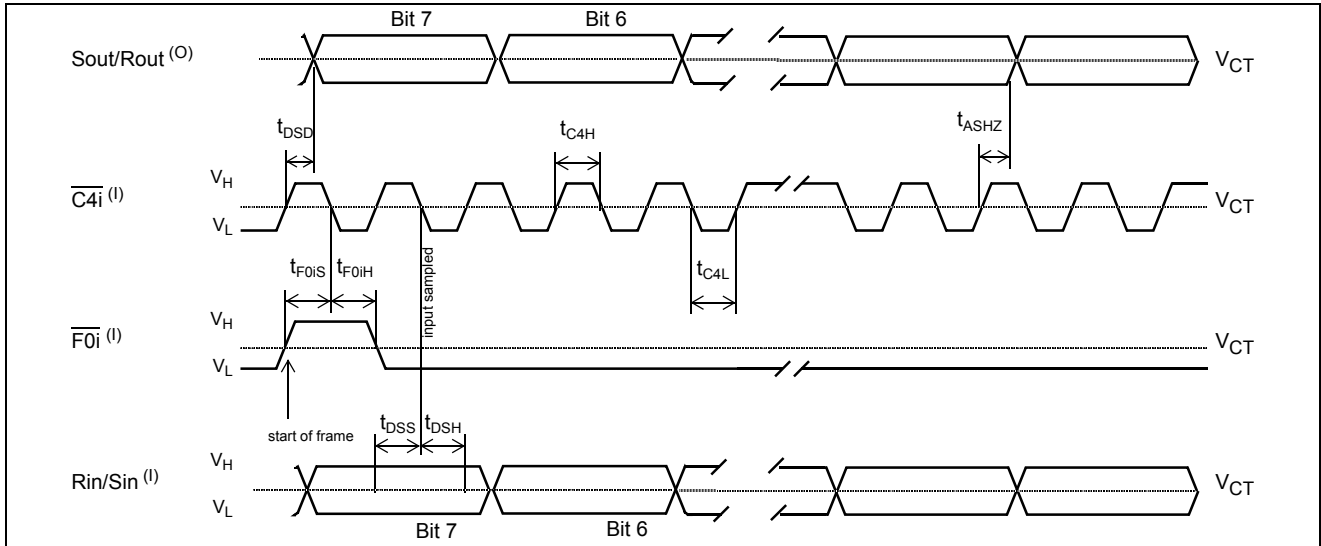

Figure 12 - GCI Data Port Timing

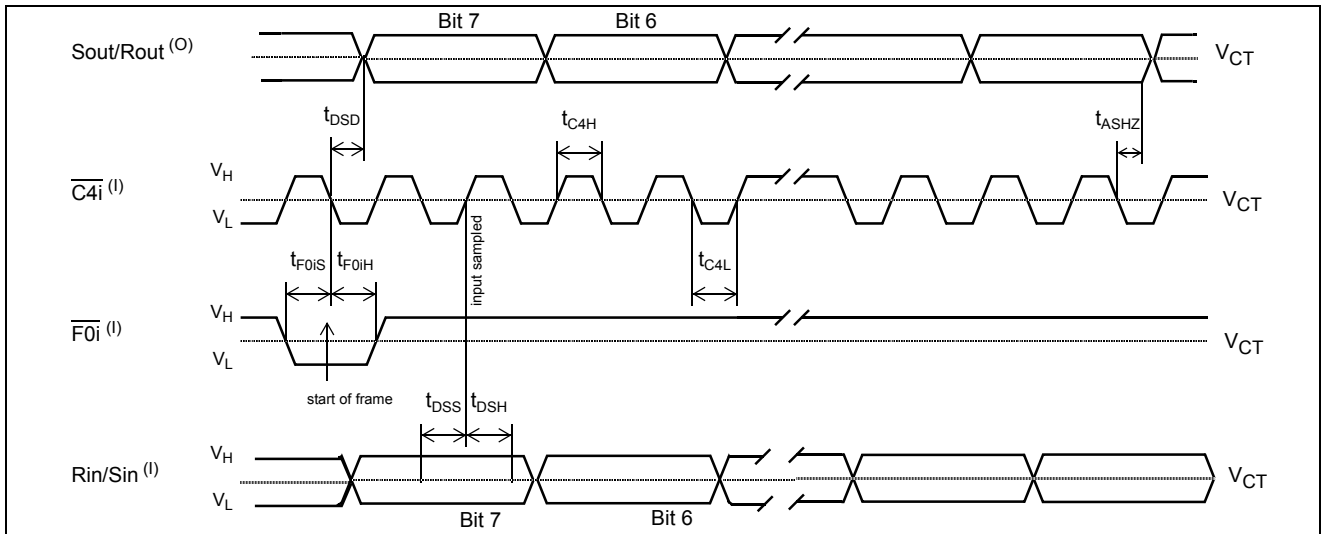

Figure 13 - ST-BUS Data Port Timing

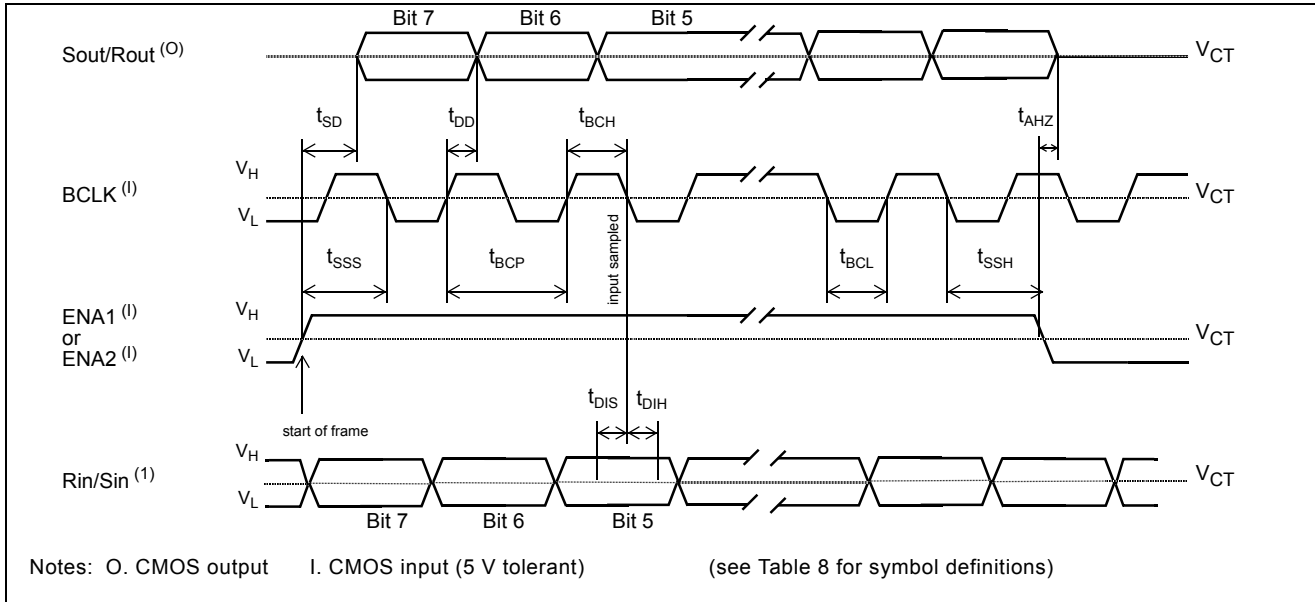

Figure 14 - SSI Data Port Timing

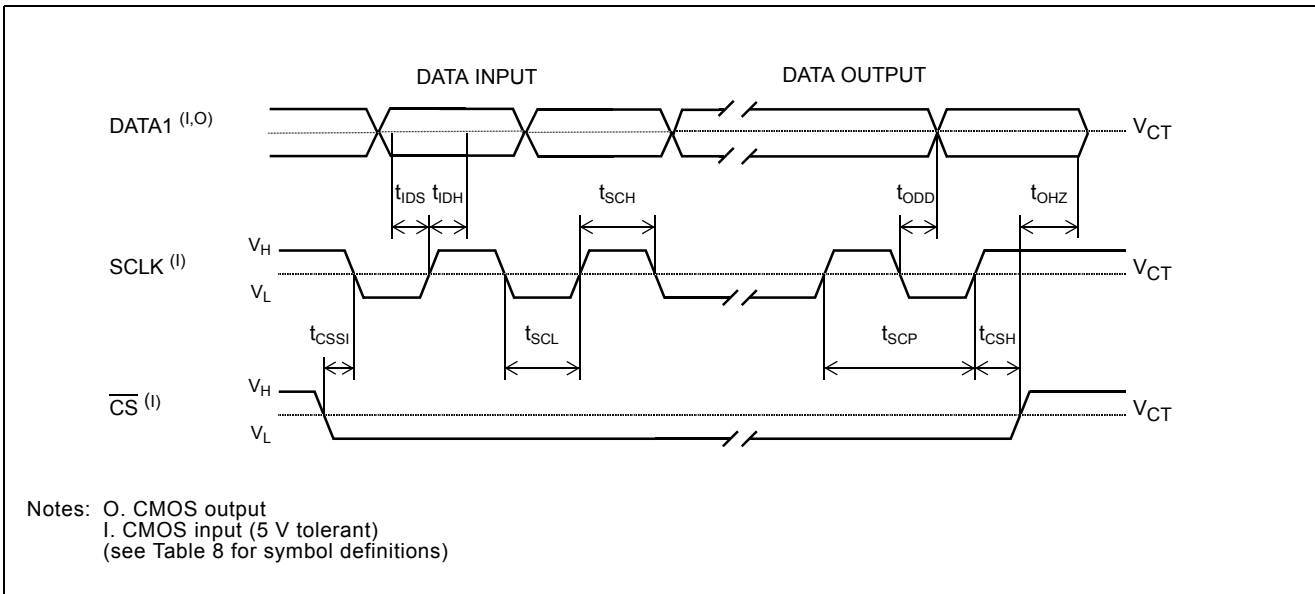

Figure 15 - INTEL Serial Microport Timing

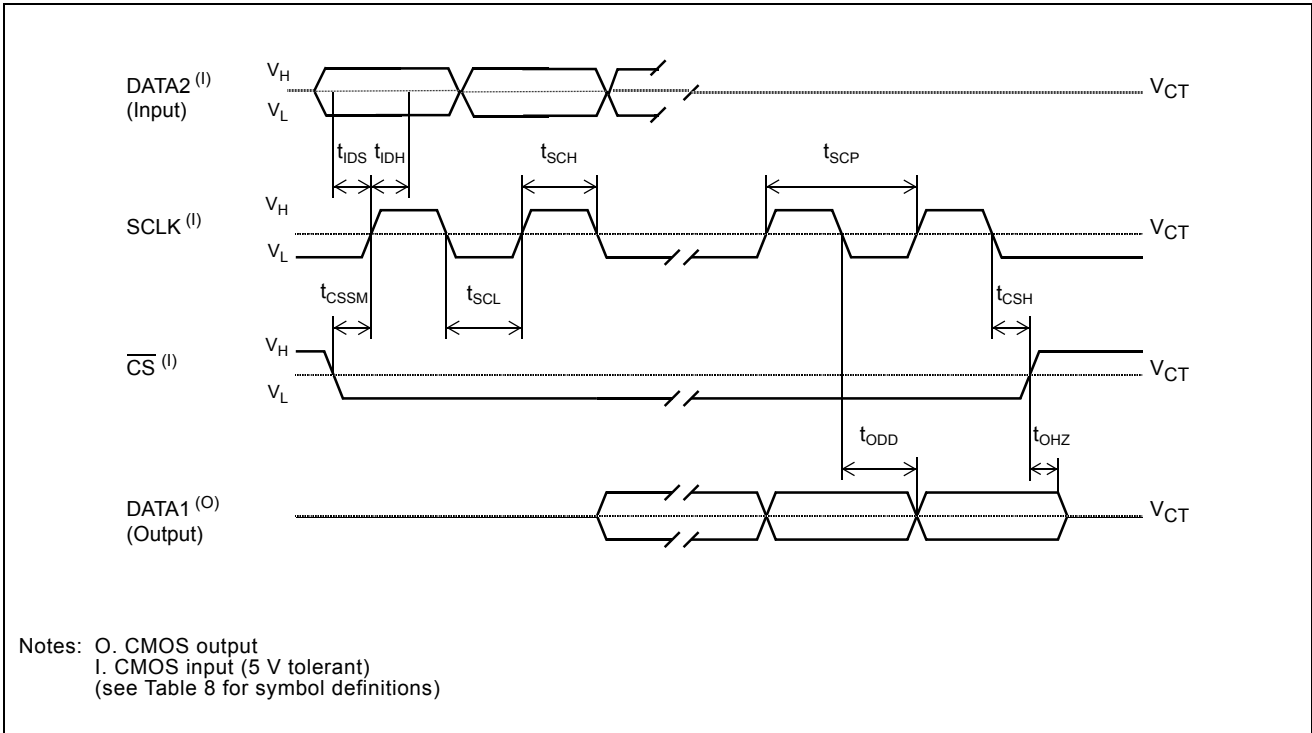
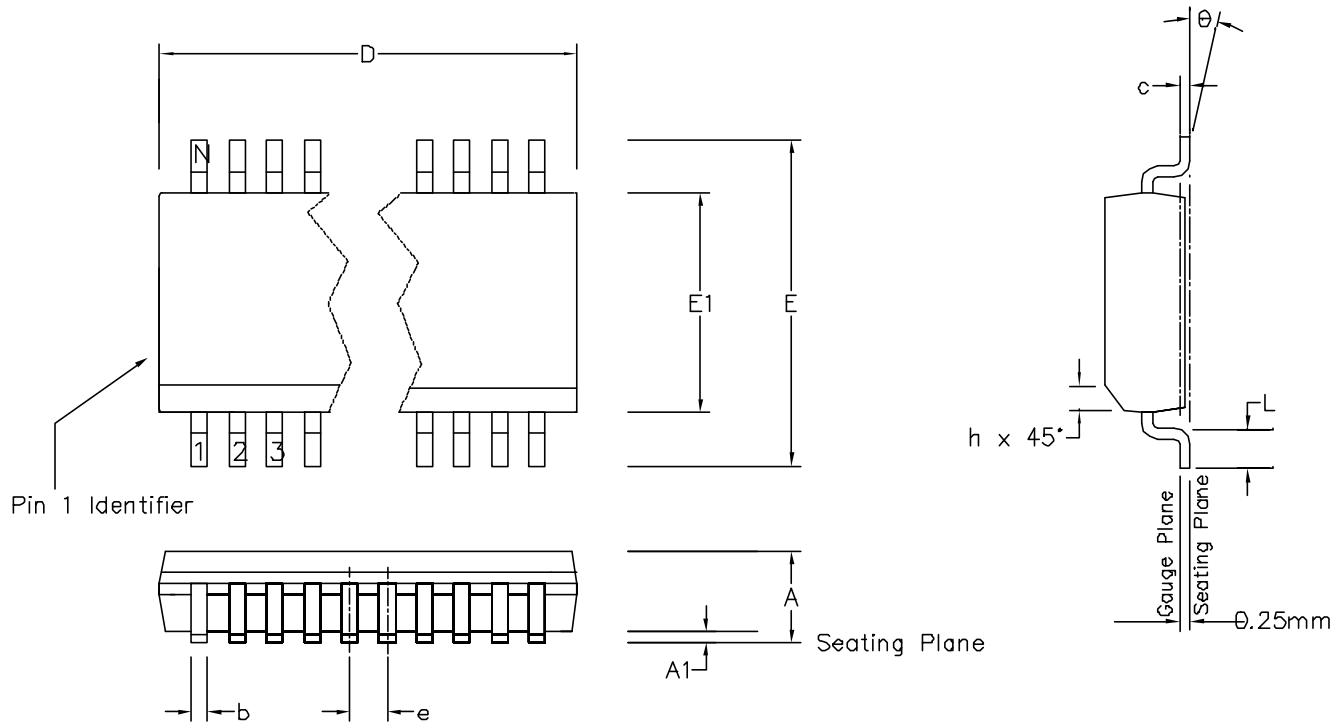

Figure 16 - Motorola Serial Microport Timing



Symbol	Altern. Dimensions In inches		Control Dimensions In millimetres	
	MIN	MAX	MIN	MAX
A	0.096	0.104	2.44	2.64
A1	0.004	0.012	0.10	0.30
D	0.598	0.612	15.20	15.54
E1	0.291	0.299	7.40	7.60
E	0.398	0.414	10.11	10.51
L	0.016	0.050	0.40	1.27
e	0.0315	BSC.	0.80	BSC.
b	0.011	0.020	0.28	0.51
c	0.009	0.013	0.23	0.32
θ	0°	8°	0°	8°
h	0.010	0.030	0.25	0.75
Pin features				
N	36			
NON JEDEC STANDARD DRAWING				

Notes:

1. Dimensioning and tolerancing per ANSI Y14.5M – 1982
2. The chamfer on the body is optional. If it is not present, a visual index feature, e.g. a dot, must be located at pin 1 position.
3. Controlling dimensions are in millimeters
4. D & E1 do not include mould flash or protrusion. But do include mold mismatch.
5. Dimension E1 does not include inter-lead flash or protrusion. These shall not exceed 0.010" per side.
6. Dimension b does not include dambar protrusion/intrusion. Allowable dambar protrusion shall be 0.13mm total in excess of b dimension.
7. Not to Scale

© Zarlink Semiconductor 2004. All rights reserved.					 ZARLINK SEMICONDUCTOR	Package Code	DD(ssop),DG(qsop)
ISSUE	1	2	3	4		Previous package codes	Package Outline for 36 lead SSOP (sometimes defined as QSOP) 7.5mm Body Width
ACN	6741	207728	212423	CDCA		NP / N,Q	
DATE	14MAR95	5NOV99	22Mar02	10Dec04			
APPRD.							GPD00008

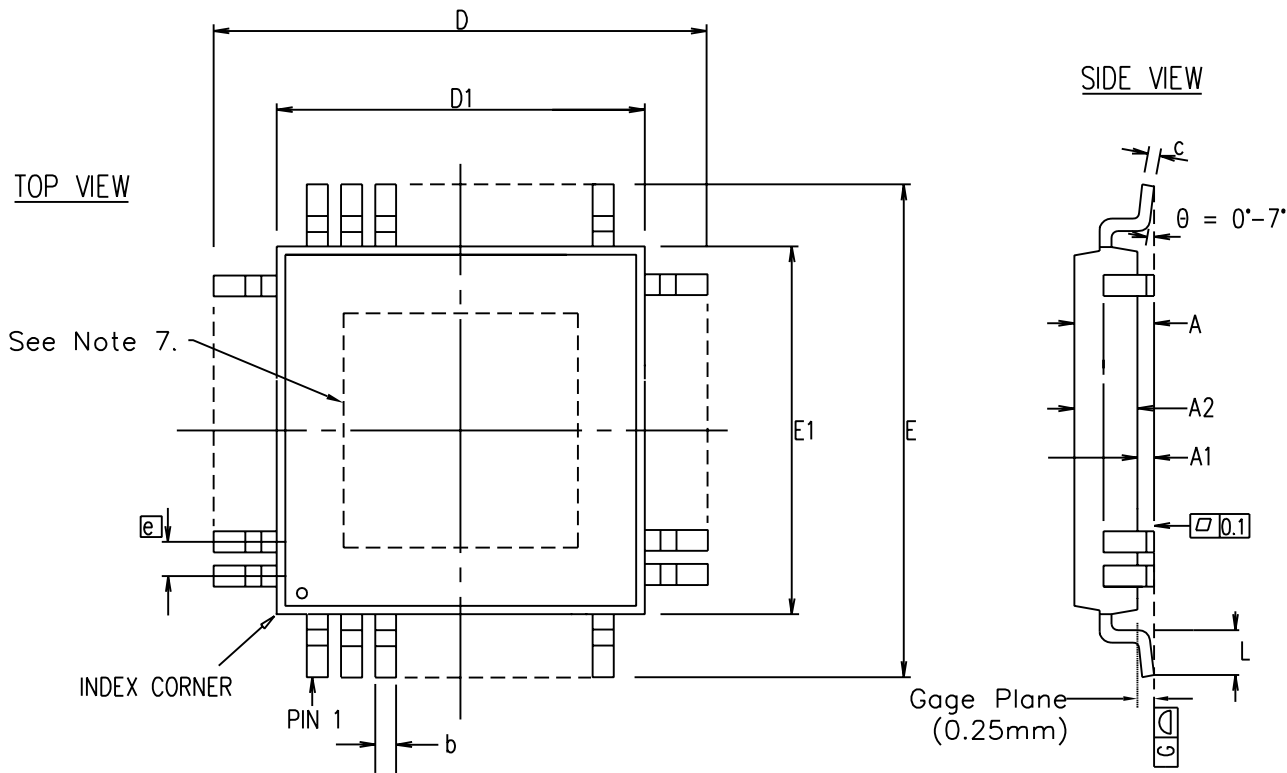

Symbol	Control Dimensions in millimetres		Altern. Dimensions in inches	
	MIN	MAX	MIN	MAX
A	---	1.20	---	0.047
A1	0.05	0.15	0.002	0.006
A2	0.95	1.05	0.037	0.041
D	9.00 BSC		0.354 BSC	
D1	7.00 BSC		0.276 BSC	
E	9.00 BSC		0.354 BSC	
E1	7.00 BSC		0.276 BSC	
L	0.45	0.75	0.018	0.030
e	0.50 BSC		0.020 BSC	
b	0.17	0.27	0.007	0.011
c	0.09	0.20	0.004	0.008
Pin features				
N	48			
ND	12			
NE	12			
NOTE	SQUARE			

Conforms to JEDEC MS-026 ABC Iss. C

Notes:

1. Pin 1 indicator may be a corner chamfer, dot or both.
2. Controlling dimensions are in millimeters.
3. The top package body size may be smaller than the bottom package body size by a max. of 0.15 mm.
4. Dimension D1 and E1 do not include mould protusion.
5. Dimension b does not include dambar protusion.
6. Coplanarity, measured at seating plane G, to be 0.08 mm max.
7. Dashed area represents exposed paddle for e-PAD Packages only.
 - See leadframe drawing for e-Pad dimension.
 - Metal area of exposed die pad shall be within 0.30mm of nominal pad size.

This drawing supersedes 418/ED/51612/002 (Swindon)

© Zarlink Semiconductor 2002 All rights reserved.				
ISSUE	1	2	3	4
ACN	201365	207083	208007	212441
DATE	28Oct96	6Jul99	14Dec99	25Mar02
APPRD.				



Previous package codes		Package Code
TP / TH / F		QD
		Package Outline for 48 lead TQFP / E-Pad TQFP (7x7x1.0mm) 2.0mm Footprint
		GPD00249

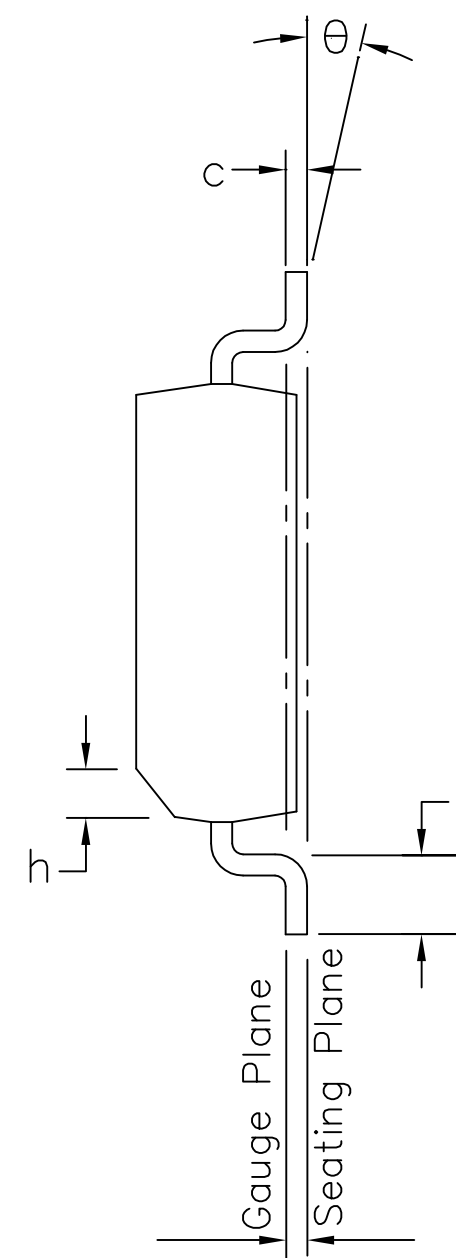
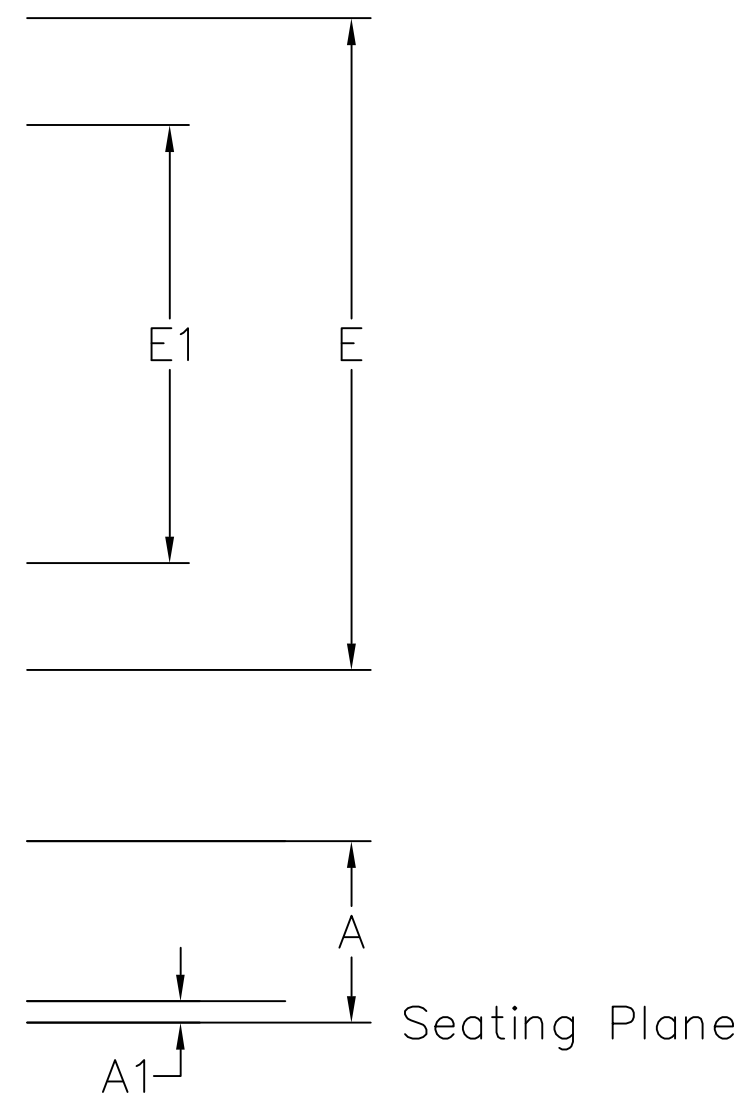
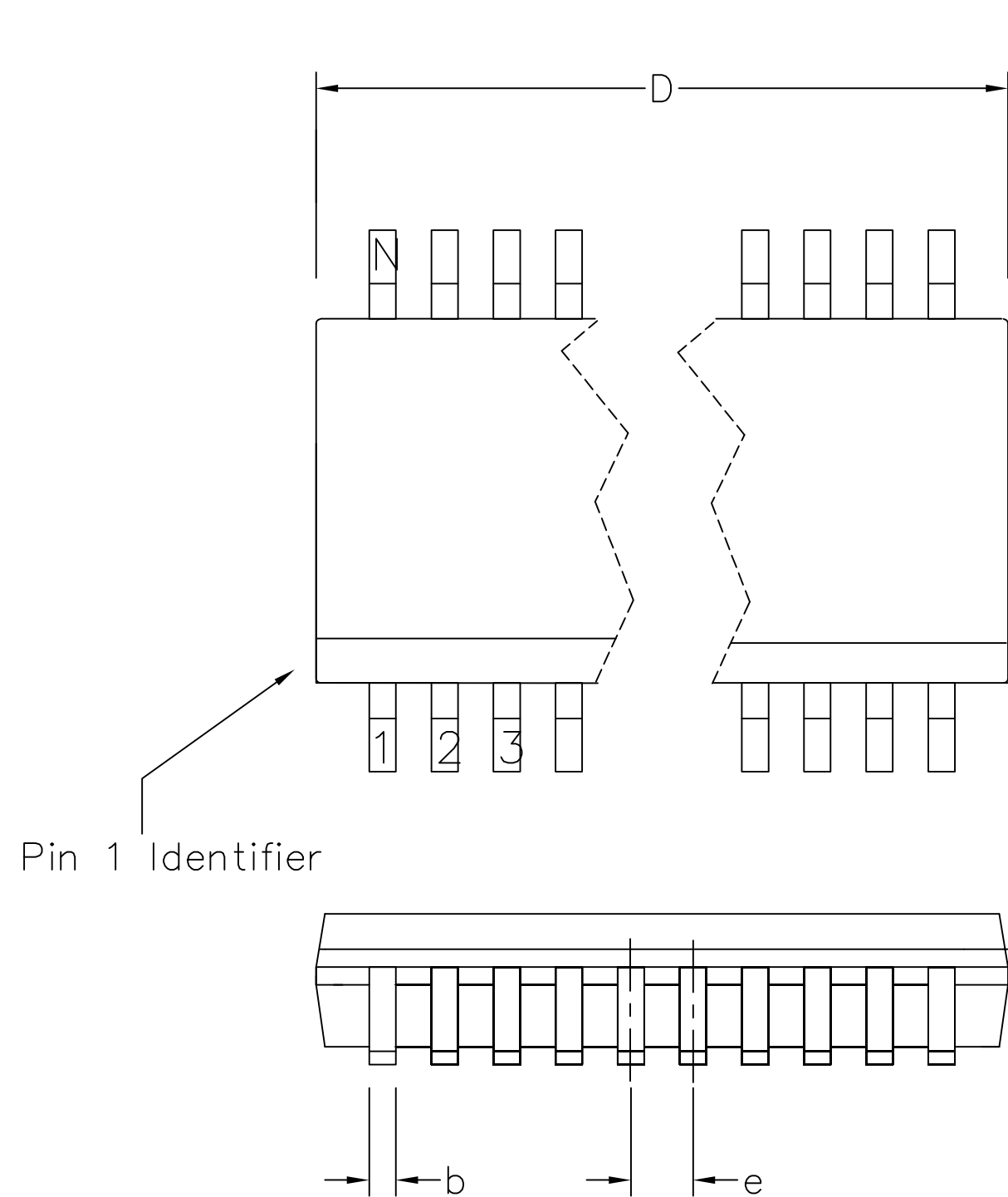

Symbol	Altern. Dimensions in inches		Control Dimensions in millimetres	
	MIN	MAX	MIN	MAX
A	0.096	0.104	2.44	2.64
A1	0.004	0.012	0.10	0.30
D	0.598	0.612	15.20	15.40
E1	0.291	0.299	7.40	7.60
E	0.398	0.414	10.11	10.51
L	0.016	0.050	0.40	1.27
e	0.0315	BSC.	0.80	BSC.
b	0.011	0.020	0.28	0.51
c	0.009	0.013	0.23	0.32
θ	0°	8°	0°	8°
h	0.018	0.0216	0.45	0.55
Pin features				
N	36			
NON JEDEC STANDARD DRAWING				

Notes:

1. The chamfer on the body is optional. If it is not present, a visual index feature, e.g. a dot, must be located at pin 1 position.
2. Controlling dimensions are in millimeters
3. D & E1 do not include mould flash or protrusion. But do include mold mismatch.
4. Dimension E1 does not include inter-lead flash or protrusion.
5. Dimension b does not include dambar protrusion/intrusion.
6. Not to Scale

© Zarlink Semiconductor 2003 All rights reserved.

ISSUE	1			
ACN				
DATE	09-02-04			
APPRD.				



Previous package codes

Q

Package Code DG

Package Outline for 36 lead QSOP, 300 mil (7.5mm) Body width

103461



**For more information about all Zarlink products
visit our Web Site at
www.zarlink.com**

Information relating to products and services furnished herein by Zarlink Semiconductor Inc. or its subsidiaries (collectively "Zarlink") is believed to be reliable. However, Zarlink assumes no liability for errors that may appear in this publication, or for liability otherwise arising from the application or use of any such information, product or service or for any infringement of patents or other intellectual property rights owned by third parties which may result from such application or use. Neither the supply of such information or purchase of product or service conveys any license, either express or implied, under patents or other intellectual property rights owned by Zarlink or licensed from third parties by Zarlink, whatsoever. Purchasers of products are also hereby notified that the use of product in certain ways or in combination with Zarlink, or non-Zarlink furnished goods or services may infringe patents or other intellectual property rights owned by Zarlink.

This publication is issued to provide information only and (unless agreed by Zarlink in writing) may not be used, applied or reproduced for any purpose nor form part of any order or contract nor to be regarded as a representation relating to the products or services concerned. The products, their specifications, services and other information appearing in this publication are subject to change by Zarlink without notice. No warranty or guarantee express or implied is made regarding the capability, performance or suitability of any product or service. Information concerning possible methods of use is provided as a guide only and does not constitute any guarantee that such methods of use will be satisfactory in a specific piece of equipment. It is the user's responsibility to fully determine the performance and suitability of any equipment using such information and to ensure that any publication or data used is up to date and has not been superseded. Manufacturing does not necessarily include testing of all functions or parameters. These products are not suitable for use in any medical products whose failure to perform may result in significant injury or death to the user. All products and materials are sold and services provided subject to Zarlink's conditions of sale which are available on request.

Purchase of Zarlink's I²C components conveys a licence under the Philips I²C Patent rights to use these components in and I²C System, provided that the system conforms to the I²C Standard Specification as defined by Philips.

Zarlink, ZL and the Zarlink Semiconductor logo are trademarks of Zarlink Semiconductor Inc.

Copyright Zarlink Semiconductor Inc. All Rights Reserved.

TECHNICAL DOCUMENTATION - NOT FOR RESALE



Компания «ЭлектроПласт» предлагает заключение долгосрочных отношений при поставках импортных электронных компонентов на взаимовыгодных условиях!

Наши преимущества:

- Оперативные поставки широкого спектра электронных компонентов отечественного и импортного производства напрямую от производителей и с крупнейших мировых складов;
- Поставка более 17-ти миллионов наименований электронных компонентов;
- Поставка сложных, дефицитных, либо снятых с производства позиций;
- Оперативные сроки поставки под заказ (от 5 рабочих дней);
- Экспресс доставка в любую точку России;
- Техническая поддержка проекта, помощь в подборе аналогов, поставка прототипов;
- Система менеджмента качества сертифицирована по Международному стандарту ISO 9001;
- Лицензия ФСБ на осуществление работ с использованием сведений, составляющих государственную тайну;
- Поставка специализированных компонентов (Xilinx, Altera, Analog Devices, Intersil, Interpoint, Microsemi, Aeroflex, Peregrine, Syfer, Eurofarad, Texas Instrument, Miteq, Cobham, E2V, MA-COM, Hittite, Mini-Circuits, General Dynamics и др.);

Помимо этого, одним из направлений компании «ЭлектроПласт» является направление «Источники питания». Мы предлагаем Вам помощь Конструкторского отдела:

- Подбор оптимального решения, техническое обоснование при выборе компонента;
- Подбор аналогов;
- Консультации по применению компонента;
- Поставка образцов и прототипов;
- Техническая поддержка проекта;
- Защита от снятия компонента с производства.



Как с нами связаться

Телефон: 8 (812) 309 58 32 (многоканальный)

Факс: 8 (812) 320-02-42

Электронная почта: org@eplast1.ru

Адрес: 198099, г. Санкт-Петербург, ул. Калинина, дом 2, корпус 4, литера А.