

Using the LM3447-A19-120VEVM

User's Guide



Literature Number: SLUU937
May 2012



WARNING

Always follow TI's set-up and application instructions, including use of all interface components within their recommended electrical rated voltage and power limits. Always use electrical safety precautions to help ensure your personal safety and the safety of those working around you. Contact TI's Product Information Center <http://support/ti.com> for further information.

Save all warnings and instructions for future reference.

Failure to follow warnings and instructions may result in personal injury, property damage, or death due to electrical shock and/or burn hazards.

The term TI HV EVM refers to an electronic device typically provided as an open framed, unenclosed printed circuit board assembly. It is intended strictly for use in development laboratory environments, solely for qualified professional users having training, expertise, and knowledge of electrical safety risks in development and application of high-voltage electrical circuits. Any other use and/or application are strictly prohibited by Texas Instruments. If you are not suitably qualified, you should immediately stop from further use of the HV EVM.

1. Work Area Safety:

- (a) Keep work area clean and orderly.
- (b) Qualified observer(s) must be present anytime circuits are energized.
- (c) Effective barriers and signage must be present in the area where the TI HV EVM and its interface electronics are energized, indicating operation of accessible high voltages may be present, for the purpose of protecting inadvertent access.
- (d) All interface circuits, power supplies, evaluation modules, instruments, meters, scopes and other related apparatus used in a development environment exceeding 50 V_{RMS}/75 VDC must be electrically located within a protected Emergency Power Off (EPO) protected power strip.
- (e) Use a stable and non-conductive work surface.
- (f) Use adequately insulated clamps and wires to attach measurement probes and instruments. No freehand testing whenever possible.

2. Electrical Safety:

- (a) De-energize the TI HV EVM and all its inputs, outputs, and electrical loads before performing any electrical or other diagnostic measurements. Revalidate that TI HV EVM power has been safely de-energized.
- (b) With the EVM confirmed de-energized, proceed with required electrical circuit configurations, wiring, measurement equipment hook-ups and other application needs, while still assuming the EVM circuit and measuring instruments are electrically live.
- (c) Once EVM readiness is complete, energize the EVM as intended.

WARNING: while the EVM is energized, never touch the EVM or its electrical circuits as they could be at high voltages capable of causing electrical shock hazard.

3. Personal Safety:

- (a) Wear personal protective equipment e.g. latex gloves and/or safety glasses with side shields or protect EVM in an adequate lucent plastic box with interlocks from accidental touch.

4. Limitation for Safe Use:

- (a) EVMs are not to be used as all or part of a production unit.

LM3447-A19-120VEVM is a Phase-Dimmable, Primary-Side Regulated LED Driver

1 Introduction

The LM3447-A19-120VEVM is a 10-W, 120-V_{AC} isolated dimmable LED driver whose form factor intended for A19/R27 applications.

2 Description

The LM3447-A19-120VEVM is a primary-side power regulated PFC controller used for commercial and residential phase-cut dimmer compatible LED lamp drivers. The LM3447-A19-120VEVM uses fixed frequency valley switching operation resulting in discontinuous current operation.

2.1 Typical Applications

- A19 Bulb Form Factor
- R27 Bulb Form Factor

2.2 Features

- Primary-Side Control
- Leading and Trailing Edge Compatible
- 50:1 Dimming Range
- Valley Switching
- Fixed Frequency Discontinuous Operation
- Thermal Foldback
- PFC
- Efficient Triac Hold Current Operation
- LED Short and Open Circuit Detection
- Thermal Foldback
- Constant Power Operation

3 Electrical Performance Specifications

Table 1. LM3447-A19-120VEVM Electrical Performance Specifications

PARAMETER	TEST CONDITIONS	MIN	TYP	MAX	UNITS
Input Characteristics					
Voltage range		90	120	135	V
Maximum input current			100		mA
Output Characteristics					
Output voltage, V_{OUT}	9 to 10 LED's	28	30	32	V
Output load current, I_{OUT}		240	275	310	mA
Output current ripple	$V_{IN} = 120 V_{AC}$		100		mApp
Output over voltage			36		V
Systems Characteristics					
Switching frequency			75		kHz
Full-load efficiency	$V_{IN} = 120 V_{AC}$		82%		
Power factor, PF			0.98		

4 Schematic

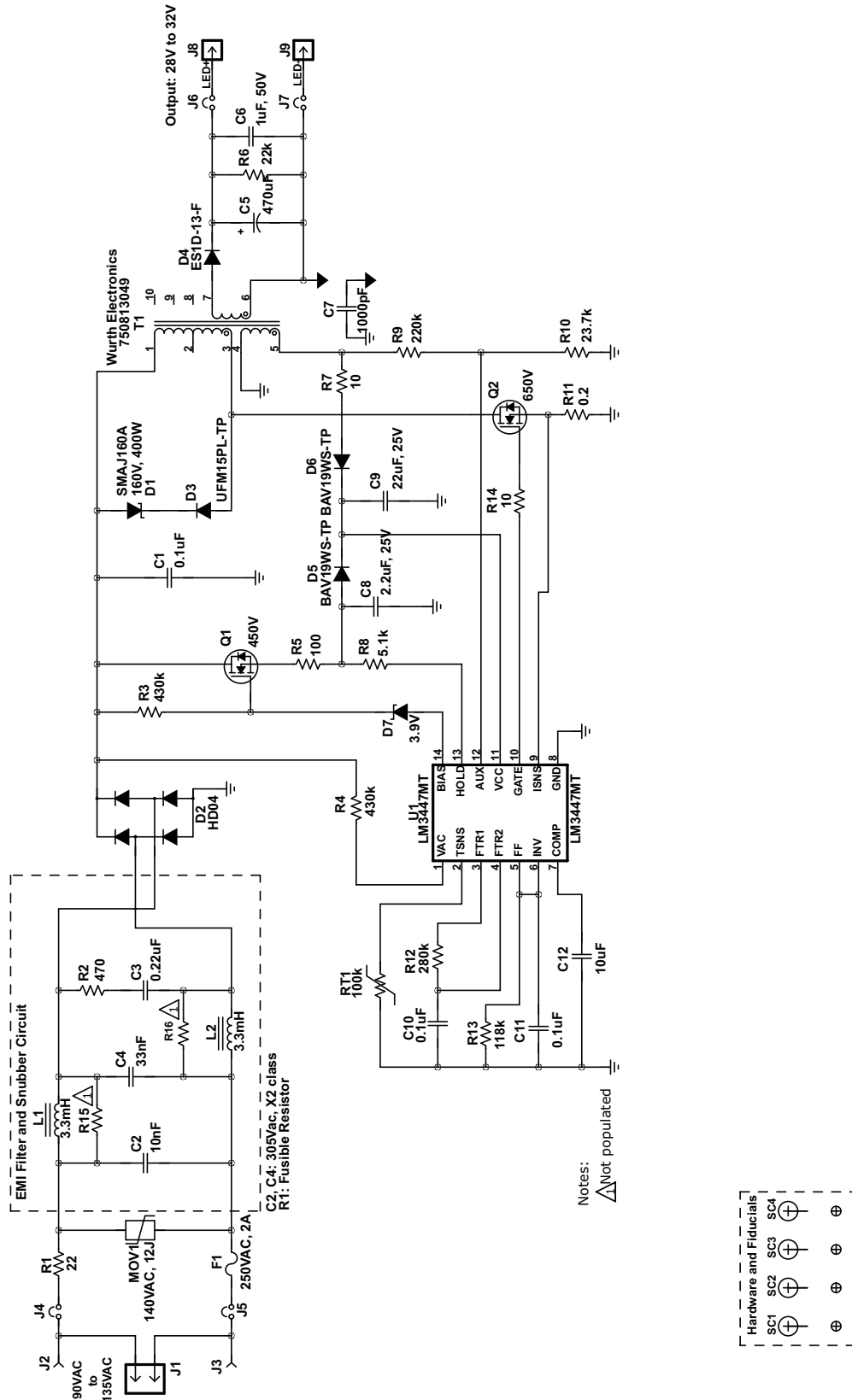

Figure 1. LM3447-A19-120VEVM Schematic

5 Test Setup

5.1 Test Equipment

Voltage Source: 105 VRMS to 135 VRMS isolated AC source PCR500LA (KIKUSUI)

Multimeters: Agilent 34401A

Power Meter: PM1000 Digital Power Meter (Voltech)

Output Load: 9 LEDs in series ($V_F = 3.2\text{ V}$ at 350 mA per LED)

Oscilloscope: TDS3045C (TEKTRONIX)

Operating Temperature: 25°C

Recommended Wire Gauge: 18 AWG not more than two feet long

5.2 Recommended Test Setup

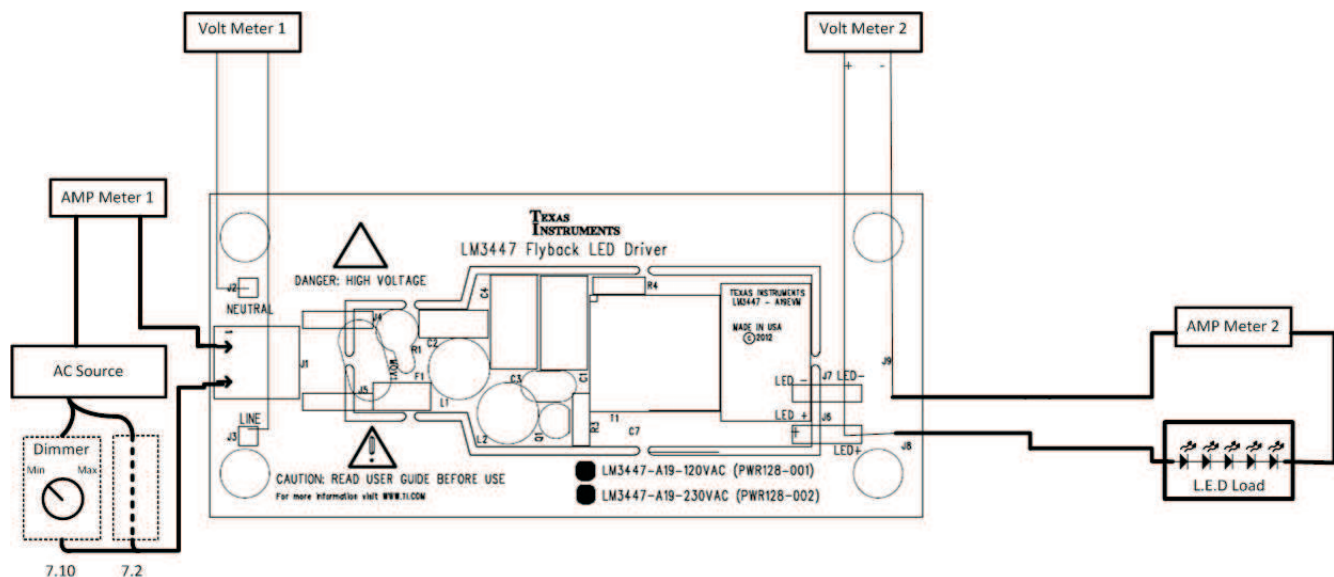

Figure 2. LM3447-A19-120VEVM Recommended Test Set Up

5.3 List of Test Points

Table 2. Test Points Functions

TEST POINTS	NAME	DESCRIPTION
TP1	Neutral	120 V _{AC} neutral connection
TP2	Line	120 V _{AC} line voltage
J8	LED+	LED anode connection
J9	LED-	LED cathode connection

6 Test Procedure

6.1 Line/Load Regulation and Efficiency Measurement Procedure

1. Connect EVM per [Figure 2](#) above. An external LED load must be used to start up the EVM.
2. Prior to turning on the AC source, set the voltage to 90 V_{RMS}.
3. Turn on the AC source.
4. Record the output voltage and current readings from Voltmeter 2 and output current reading from Ammeter 2 and input voltage reading from Voltmeter 1 and current from Ammeter 1.
5. Increase output voltage by 5 V_{RMS}.
6. Repeat steps 4 and 5 until 135 V_{AC} is reached.
7. Refer to [Section 6.2](#) for shutdown procedure.

6.2 Equipment Shutdown

1. Turn off equipment.
2. Make sure capacitors are discharged.

6.3 EVM Phase Angle Decode vs LED Current

1. Connect EVM per [Figure 2](#) above. An external LED load must be used to start up the EVM.
2. Prior to turning on the AC source, set the voltage to 120 VRMS.
3. Connect scope probe to EVM per [Figure 2](#) above to bridge rectifier output.
4. Turn on the AC source.
5. Record the output voltage and current readings from Voltmeter 2 and output current reading from Ammeter 2 and input voltage reading from Voltmeter 1 and current from Ammeter 1.
6. Set dimmer to minimum setting and vary by 1.0 msec till 8 msec is reached and record in 5 above.
7. Refer to [Section 6.2](#) for shutdown procedure.

NOTE: Scope must be isolated.

7 Performance Data and Typical Characteristic Curves

Figure 3 through Figure 26 present typical performance curves for LM3447-A19-120VEVM.

7.1 Efficiency

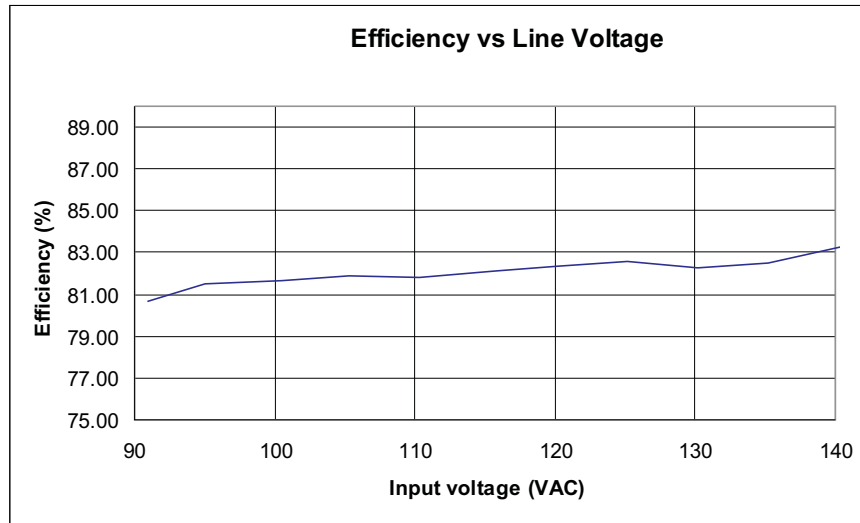

Figure 3. LM3447-A19-120VEVM Efficiency

7.2 Power Factor

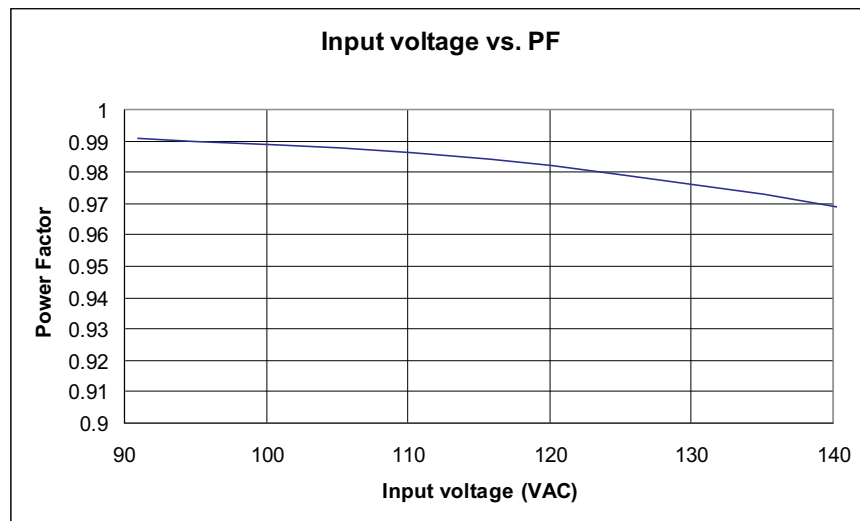

Figure 4. LM3447-A19-120VEVM Power Factor vs Line Voltage

7.3 Line Regulation

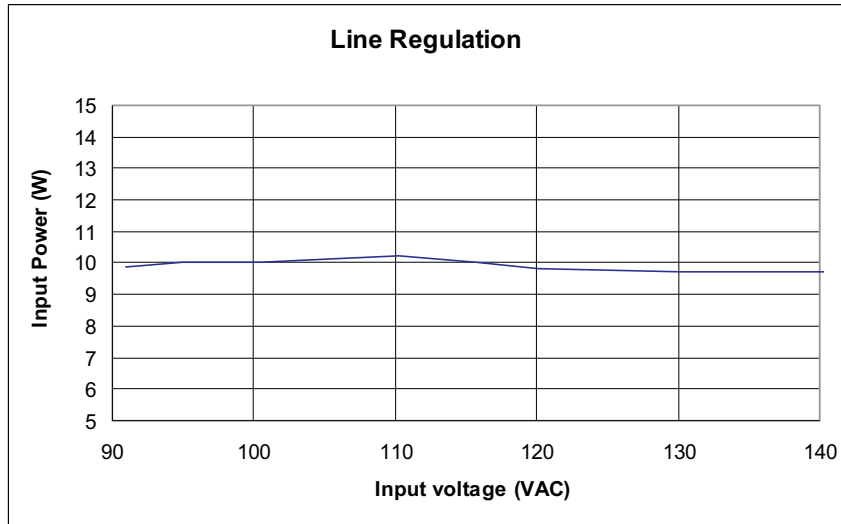

Figure 5. LM3447-A19-120VEVM Input Power Regulation

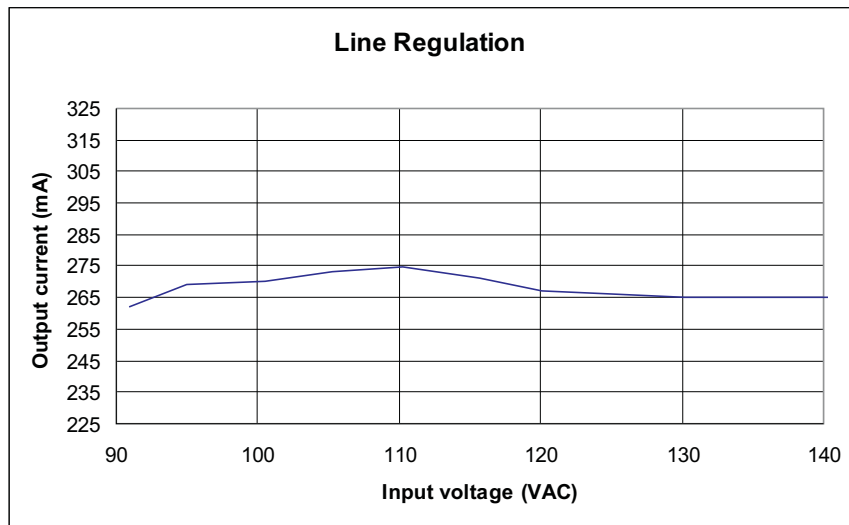

Figure 6. LM3447-A19-120VEVM LED Current Regulation

7.4 Input Current THD

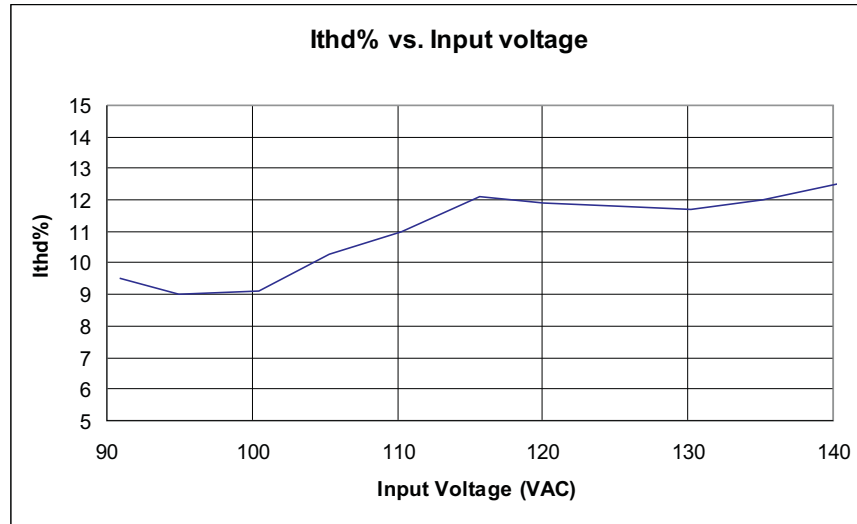

Figure 7. LM3447-A19-120VEVM- Ithd % vs Line Voltage

7.5 Output Ripple

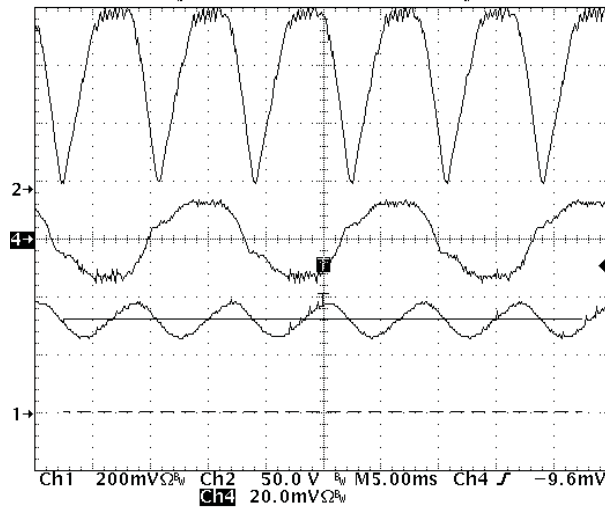

Figure 8. Output Ripple
(Ch1 - LED current Ch2 - rectified line voltage Ch4- line current 200 mA/div)

7.6 Switch Node Voltage Valley Switching

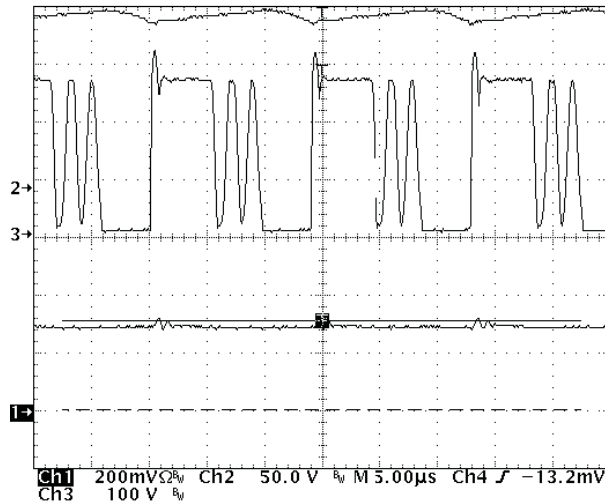

Figure 9. Switch Node Waveform
(Ch1 - LED current Ch2- switch node Ch3 - rectified line voltage)

7.7 Triac Dimmer LED Current vs Conduction Angle

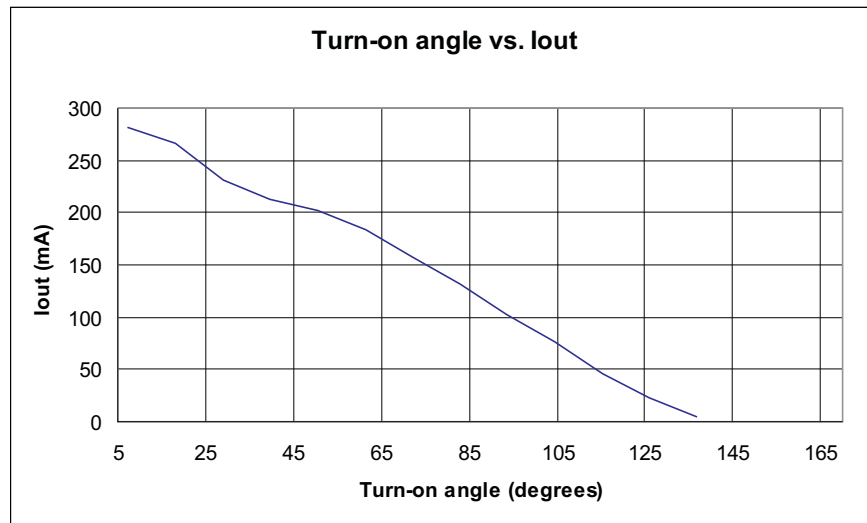

Figure 10. LED Current vs Conduction Angle

7.8 Turn-On Angle vs Input Power

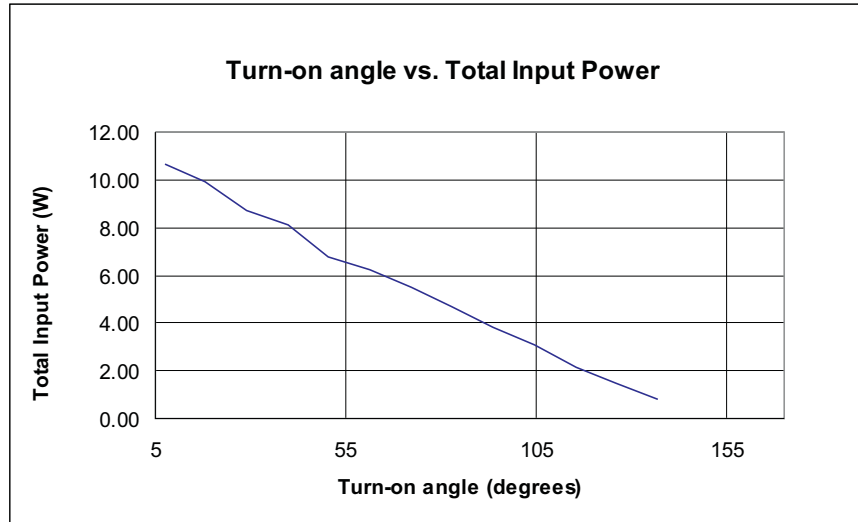

Figure 11. Turn-On Angle vs. Input Power

7.9 Input/Output Current and Line Voltage Waveforms vs. Dimmer Setting

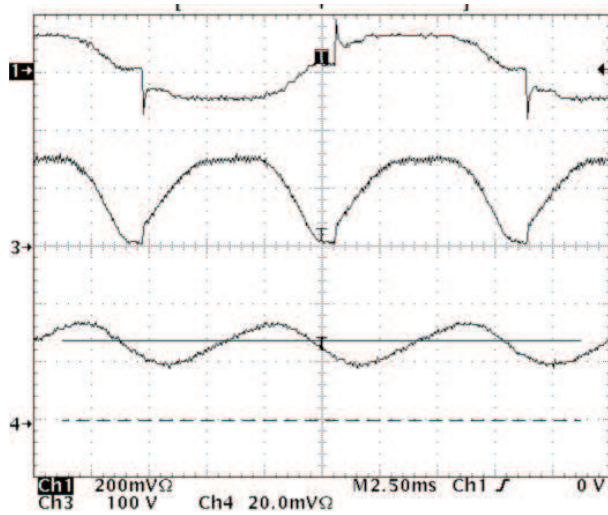

Figure 12. Dimmer Full
(Ch4- LED current Ch3 - rectified line voltage Ch1 – line current)

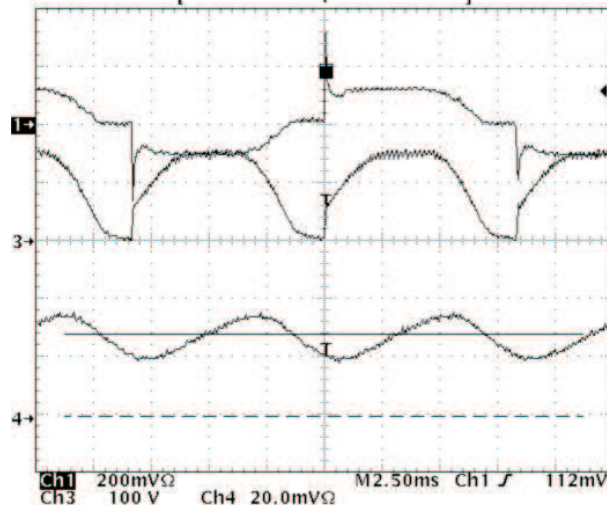

Figure 13. Dimmer 8 ms
(Ch4- LED current Ch3 - rectified line voltage Ch1 – line current)

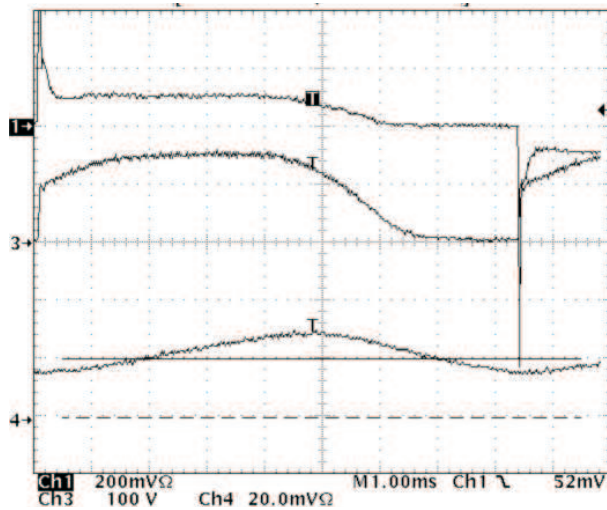

Figure 14. Dimmer 7 ms
(Ch4- LED current Ch3 - rectified line voltage Ch1 – line current)

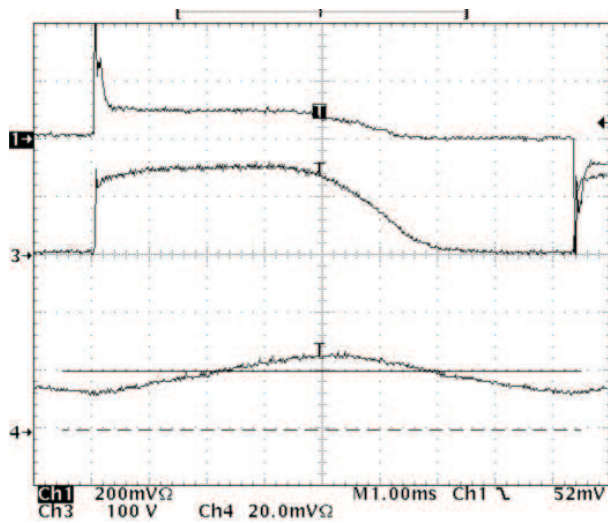

Figure 15. Dimmer 6 ms
(Ch4- LED current Ch3 - rectified line voltage Ch1 – line current)

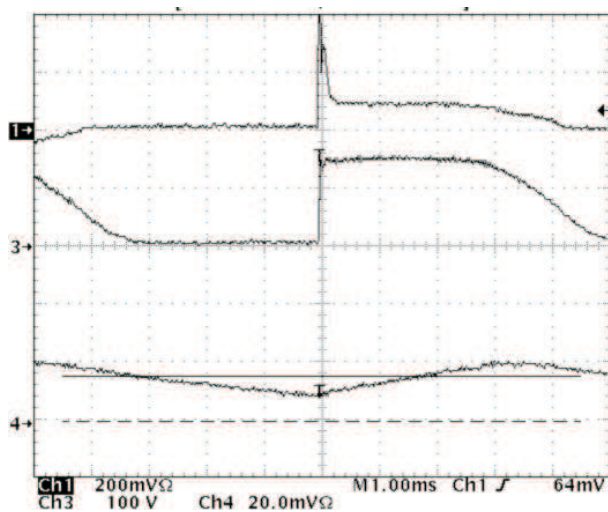

Figure 16. Dimmer 5 ms
(Ch4- LED current Ch3 - rectified line voltage Ch1 – line current)

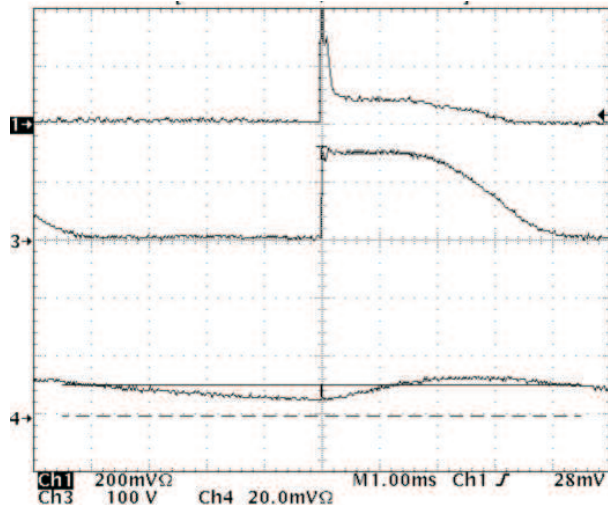

Figure 17. Dimmer 4 ms
 (Ch4- LED current Ch3 - rectified line voltage Ch1 – line current)

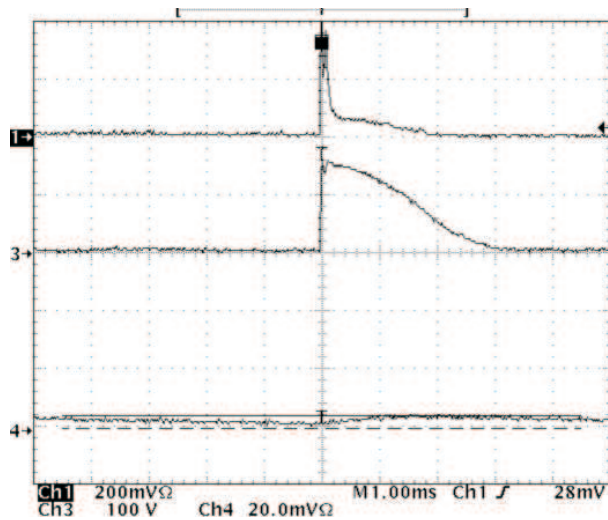

Figure 18. Dimmer 3 ms
 (Ch4- LED current Ch3 - rectified line voltage Ch1 – line current)

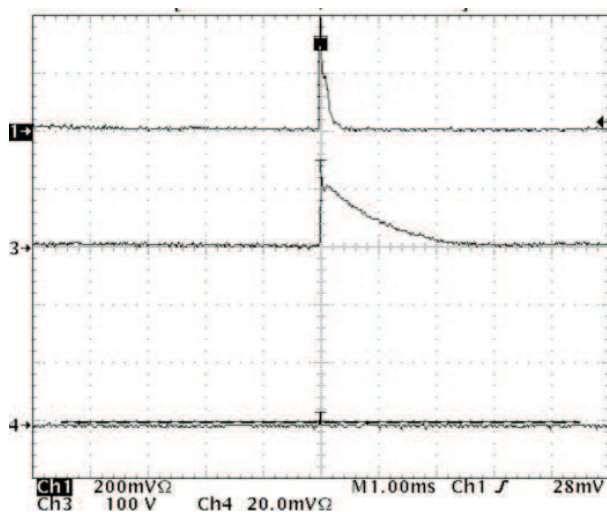

Figure 19. Dimmer 2.0 ms
(Ch4- LED current Ch3 - rectified line voltage Ch1 – line current)

7.10 Current Sense Waveform

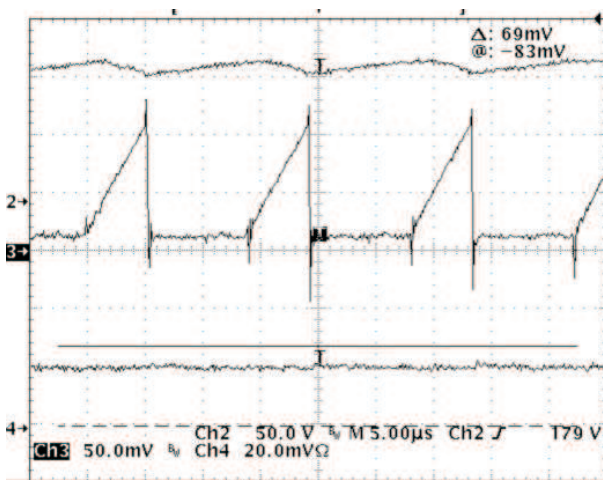

Figure 20. Current Sense Waveform
(Ch4- LED current Ch2 - rectified line voltage Ch3 –R11 Current Sense)

7.11 LED Open and Short Circuit Waveforms

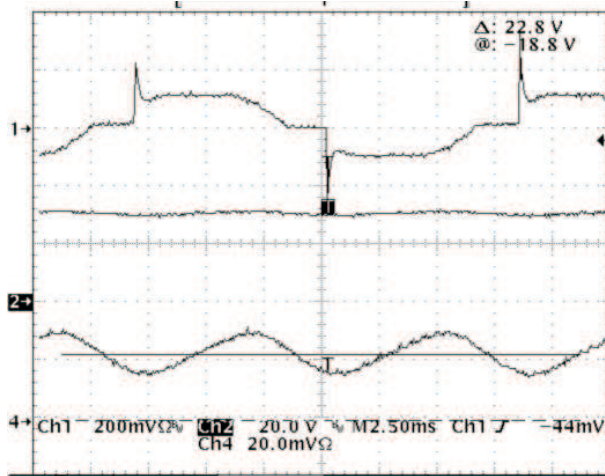

Figure 21. Pre-Open Circuit Waveforms
(Ch4- LED current Ch2- LED voltage Ch1 – line current)

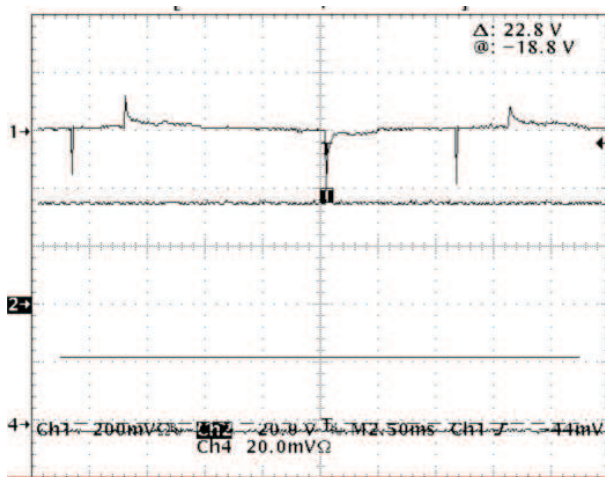

Figure 22. Open Circuit Waveforms
(Ch4- LED current Ch2- LED voltage Ch1 – line current)

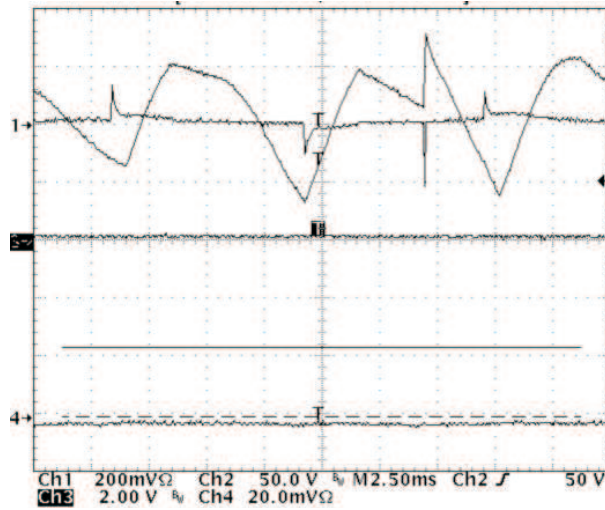

Figure 23. Open Circuit Waveforms
 (Ch4- LED current Ch2 - line voltage Ch1 – line current)

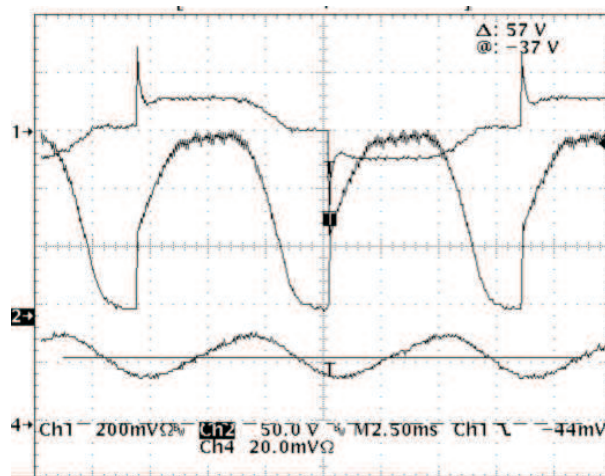

Figure 24. Pre-Short Circuit Waveforms
 (Ch4- LED current Ch2 - rectified line voltage Ch1 – line current)

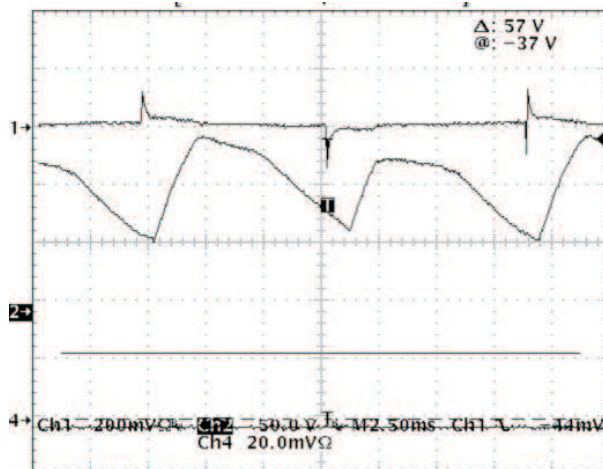

Figure 25. Short Circuit Waveforms
(Ch4- LED current Ch2 - rectified line voltage Ch1 – line current)

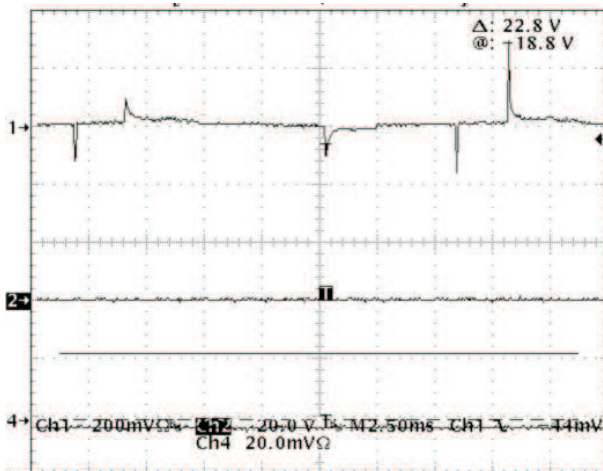
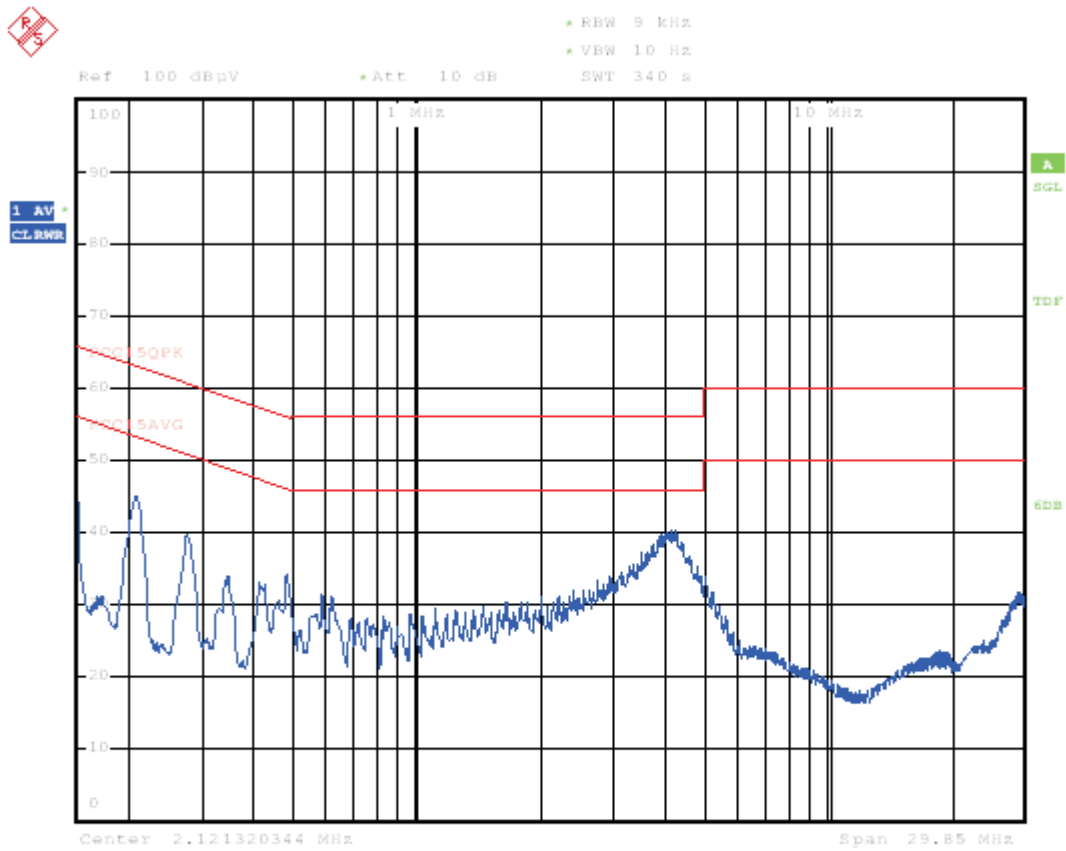

Figure 26. Short Circuit Waveforms
(Ch4- LED current Ch2- LED voltage Ch1 – line current)

7.12 EMI Plot



Date: 10.APR.2012 15:43:21

Figure 27. EMI Plot

7.13 Transformer Specification

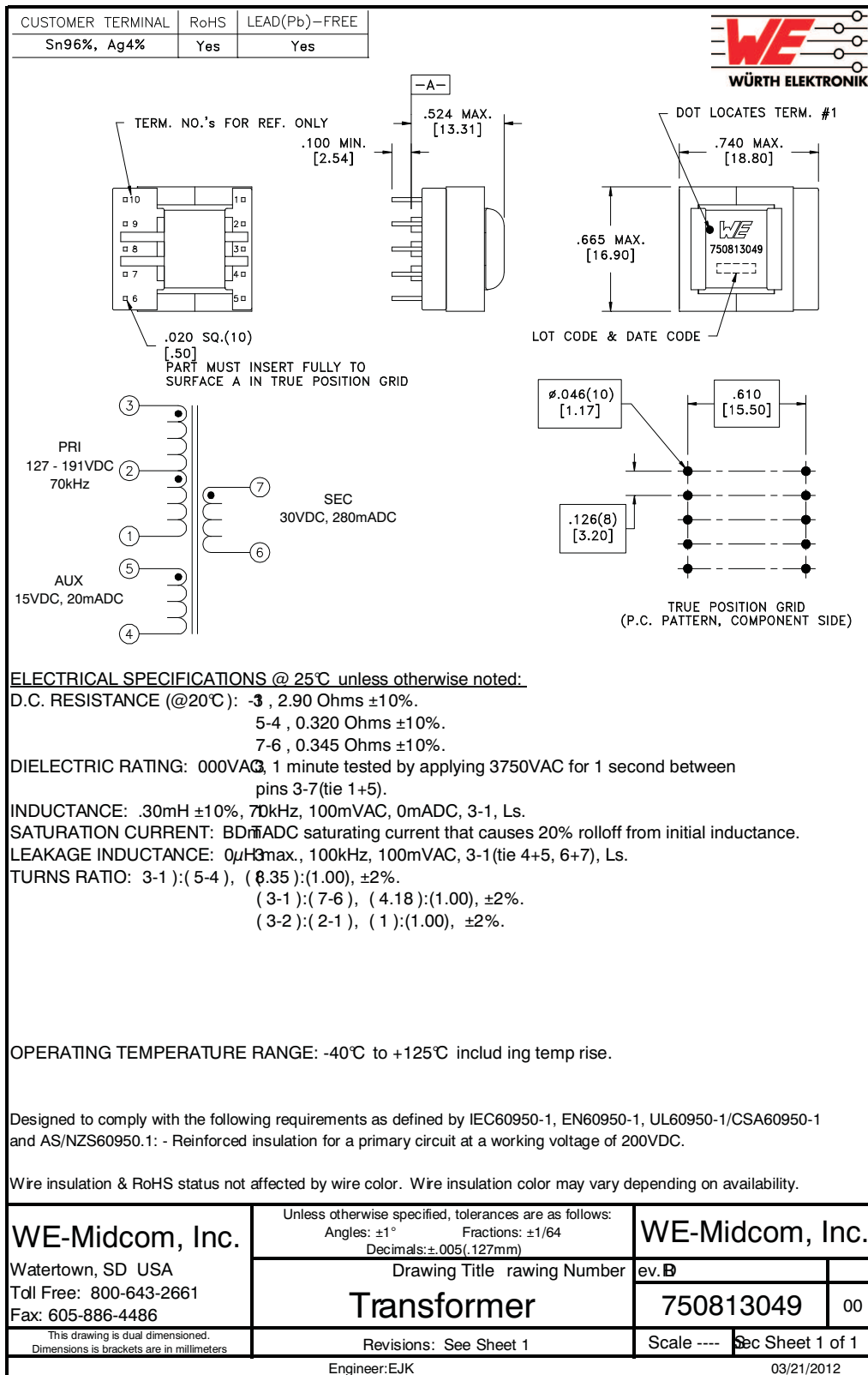

Figure 28. Transformer Specification

8 EVM Assembly Drawing and PCB Layout

The following figures (Figure 29 through Figure 32) show the design of the LM3447EVM-128 printed circuit board.

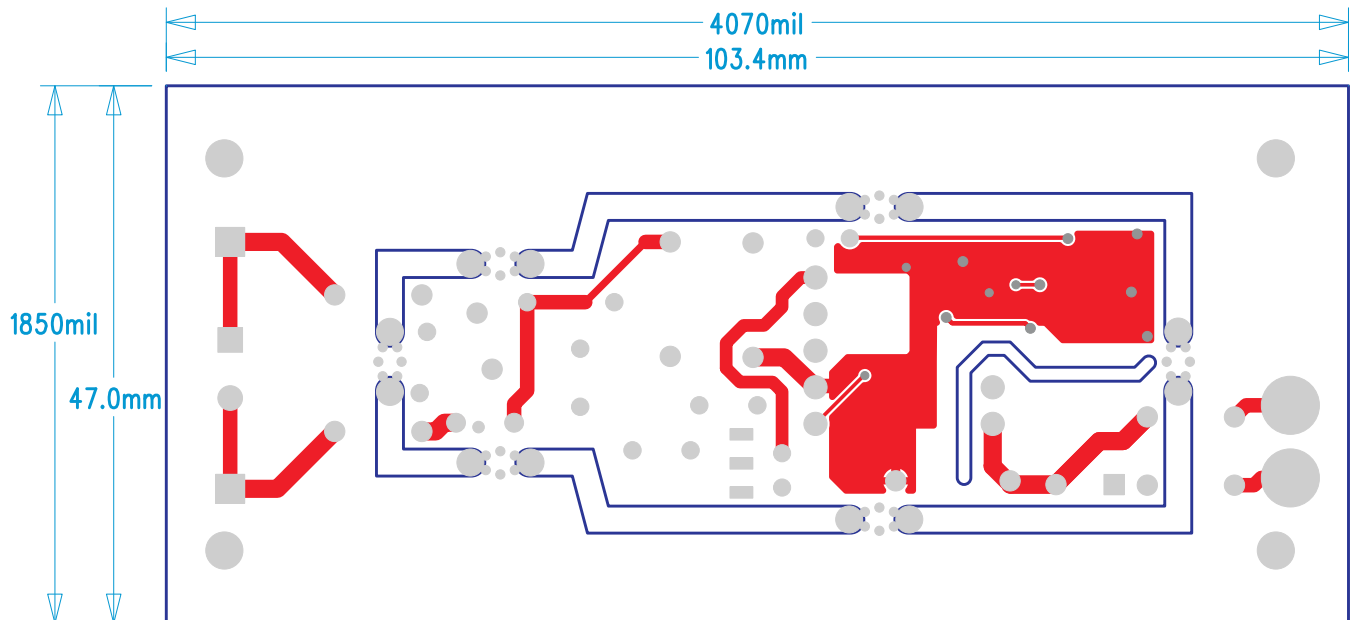

Figure 29. LM3447-A19-120VEVM Top Layer Copper (top view)

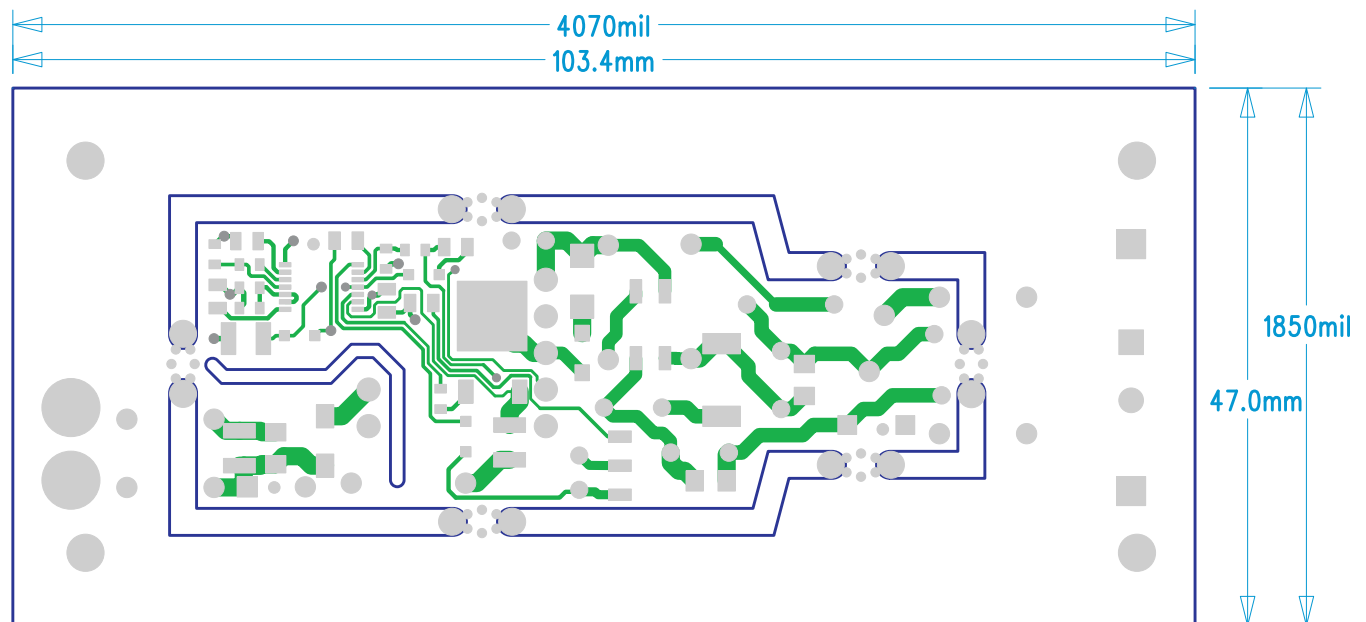

Figure 30. LM3447-A19-120VEVM Bottom Layer Copper (bottom view)

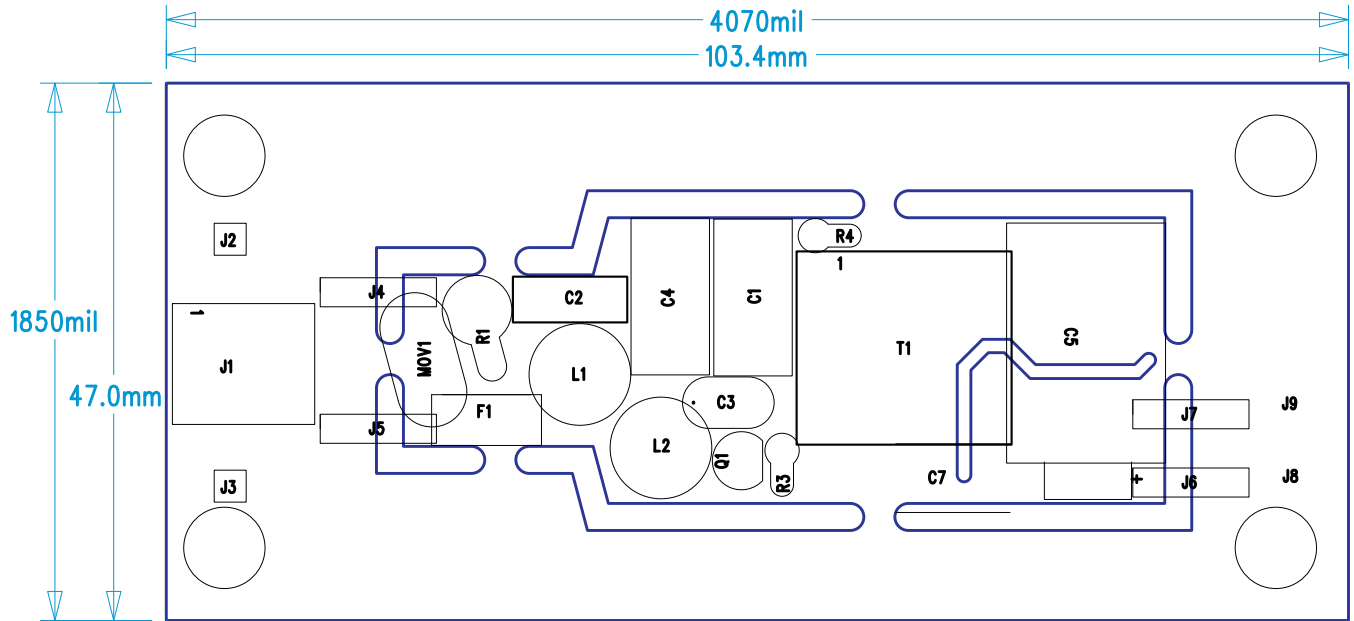

Figure 31. LM3447-A19-120VEVM Top Assembly Drawing (top view)

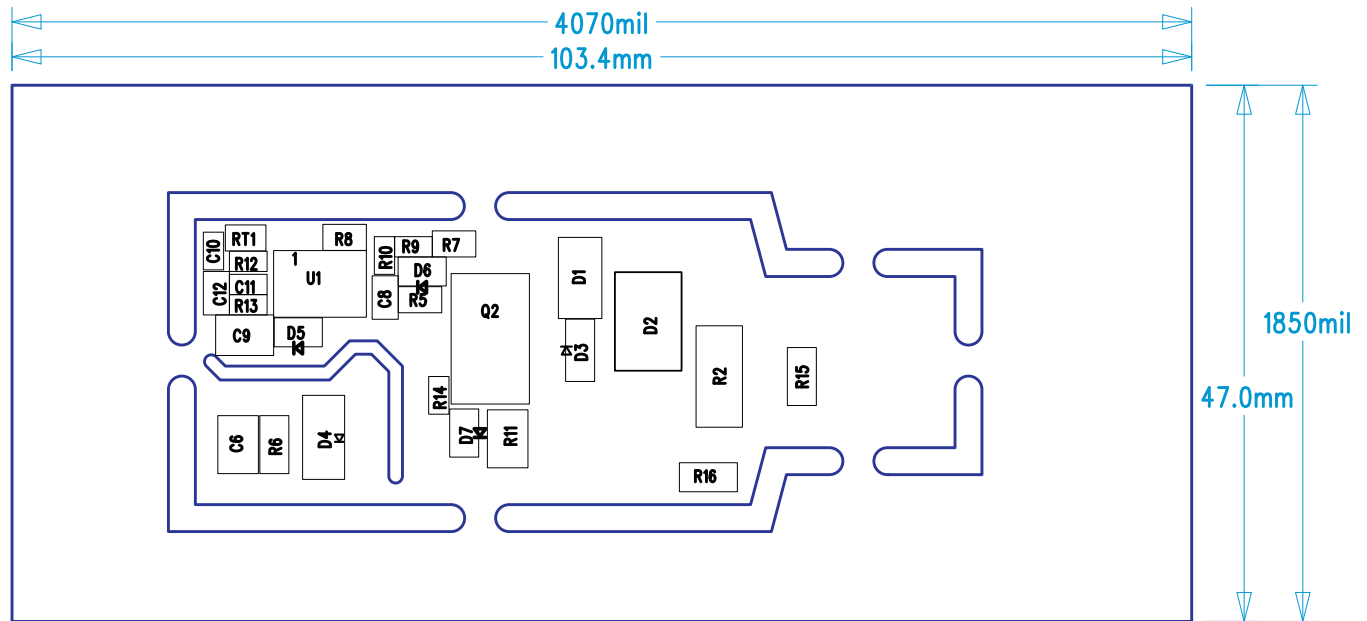

Figure 32. LM3447-A19-120VEVM Bottom Assembly Drawing (bottom view)

9 List of Materials

The EVM components list according to the schematic shown in [Figure 1](#).

Table 3. LM3447-A19-120VEVM List of Materials

QTY	REFDES	DESCRIPTION	MFR	PART NUMBER
2	C10,C11	Capacitor ceramic, 0.1 μ F, 16 V, 603	STD	STD
1	C12	Capacitor ceramic, 10 μ F, 6.3 V, 805	STD	STD
1	C6	Capacitor ceramic, 1.0 μ F, 1210	STD	STD
1	C7	Capacitor, 1000 pF, X1Y1, 250 V_{AC}	TDK	CD85-E2GA102MYNS
1	C2	Capacitor film, 10 nF, 310 V_{AC} , X2	Vishay/BC	BFC233820103
1	C5	Capacitor aluminum, 470 μ F 50V	Vishay/BC	MAL214651471E3
1	C4	Capacitor, 305 V_{AC} , 33 nF	Epcos	B32921C3333M
1	C1	Capacitor, 0.1 μ F, leaded, 305 V_{AC}	Epcos	B32921C3104M189
1	C3	Capacitor, 0.22 μ F, 250 V	Vishay	FK20X7R2E224K
1	D2	Bridge rectifier, 400 V, 0.8 A, HD04	Diodes, Inc	HD04
2	D5, D6	Diode, small signal, 250 mA, SOD-323	Micro Commercial	BAV19WS-TP
1	D3	Diode, SMD ultrafast rectifier 1 A, 600 V	Micro Commercial	UFM15PL-TP
1	D4	Diode, super fast rectifier,	Diodes, Inc	ES1D
1	D7	Diode, Zener, 3.9 V, 200 mW, SOD-323	On Semi	MM3Z23V9T1G
1	D1	Diode, SMT TVS 400 W, 160 V	Littlefuse	SMAJ160A
1	F1	Fuse, slow, 250 V_{AC} , 2 A, radial	Bel Fuse inc	RST2
2	L1,L2	Inductor, EMI, 140 mA, 3.3 mH	TDK	TSL0808RA-333KR17-P
1	MOV1	MOV, V_{MAX} 242 V_{DC} , V_{MIN} 198 V_{DC}	Littelfuse Inc	V140LA2P
1	R14	Resistor, chip, 10 Ω , 1/16 W, 603	STD	STD
1	R13	Resistor, chip, 118 k Ω , 1/16 W, 603	STD	STD
1	R9	Resistor, chip, 220 k Ω , 1/16 W, 603	STD	STD
1	R10	Resistor, chip, 23.7 k Ω , 1/16 W, 603	STD	STD
1	R12	Resistor, chip, 280 k Ω , 1/16W, 603	STD	STD
2	R3,R4	Resistor, chip, 430 k Ω , 0.25 W, 1%	Vishay Dale	HVR2500004303F, R500
1	R1	Resistor, Fusible, 22 Ω , 2 W, 5%	EMC-22RKI	Welwyn
1	R7	Resistor, chip, 10 Ω , 1/10 W, \pm 5% 805	STD	STD
1	R5	Resistor, chip, 100 Ω , 1/10 W, \pm 5% 805	STD	STD
1	R8	Resistor, chip, 5.1 k Ω , 1/10 W, \pm 5% 805	STD	STD
DNP	R15,R16	Resistor, chip, 10 k Ω , 1/4 W, \pm 5% 1206	STD	STD
1	R6	Resistor, chip, 22 k Ω , 1/4 W, \pm 5% 1206	STD	STD
1	R11	Resistor, chip, 0.2 Ω , 1/2 W, 1210	Vishay Dale	RCWL1210R200JNE A
1	R8	Resistor, chip, 470 Ω , 1.5 W, 5%, 2512	Vishay Dale	CRCW2512470RJ, NEGHP
1	RT1	"Thermistor, NTC, 100 k Ω , 0805	Murata	NCP21WF104J03RA
1	Q2	MOSFET, N-channel, 650 V, 7 A, 600 m Ω , DPAK	ST Micro	STD8N65M5
1	Q1	MOSFET, 450 V, 600 mA, 2 W	ST Micro	STQ3N45K3-AP
1	U1	Dimmable LED Controller TSSOP	TI	LM3447MT
	T1	EE16, 1.3 mH, 4.17:1	Würth	750813049

Evaluation Board/Kit Important Notice

Texas Instruments (TI) provides the enclosed product(s) under the following conditions:

This evaluation board/kit is intended for use for **ENGINEERING DEVELOPMENT, DEMONSTRATION, OR EVALUATION PURPOSES ONLY** and is not considered by TI to be a finished end-product fit for general consumer use. Persons handling the product(s) must have electronics training and observe good engineering practice standards. As such, the goods being provided are not intended to be complete in terms of required design-, marketing-, and/or manufacturing-related protective considerations, including product safety and environmental measures typically found in end products that incorporate such semiconductor components or circuit boards. This evaluation board/kit does not fall within the scope of the European Union directives regarding electromagnetic compatibility, restricted substances (RoHS), recycling (WEEE), FCC, CE or UL, and therefore may not meet the technical requirements of these directives or other related directives.

Should this evaluation board/kit not meet the specifications indicated in the User's Guide, the board/kit may be returned within 30 days from the date of delivery for a full refund. **THE FOREGOING WARRANTY IS THE EXCLUSIVE WARRANTY MADE BY SELLER TO BUYER AND IS IN LIEU OF ALL OTHER WARRANTIES, EXPRESSED, IMPLIED, OR STATUTORY, INCLUDING ANY WARRANTY OF MERCHANTABILITY OR FITNESS FOR ANY PARTICULAR PURPOSE.**

The user assumes all responsibility and liability for proper and safe handling of the goods. Further, the user indemnifies TI from all claims arising from the handling or use of the goods. Due to the open construction of the product, it is the user's responsibility to take any and all appropriate precautions with regard to electrostatic discharge.

EXCEPT TO THE EXTENT OF THE INDEMNITY SET FORTH ABOVE, NEITHER PARTY SHALL BE LIABLE TO THE OTHER FOR ANY INDIRECT, SPECIAL, INCIDENTAL, OR CONSEQUENTIAL DAMAGES.

TI currently deals with a variety of customers for products, and therefore our arrangement with the user **is not exclusive.**

TI assumes **no liability for applications assistance, customer product design, software performance, or infringement of patents or services described herein.**

Please read the User's Guide and, specifically, the Warnings and Restrictions notice in the User's Guide prior to handling the product. This notice contains important safety information about temperatures and voltages. For additional information on TI's environmental and/or safety programs, please contact the TI application engineer or visit www.ti.com/esh.

No license is granted under any patent right or other intellectual property right of TI covering or relating to any machine, process, or combination in which such TI products or services might be or are used.

FCC Warning

This evaluation board/kit is intended for use for **ENGINEERING DEVELOPMENT, DEMONSTRATION, OR EVALUATION PURPOSES ONLY** and is not considered by TI to be a finished end-product fit for general consumer use. It generates, uses, and can radiate radio frequency energy and has not been tested for compliance with the limits of computing devices pursuant to part 15 of FCC rules, which are designed to provide reasonable protection against radio frequency interference. Operation of this equipment in other environments may cause interference with radio communications, in which case the user at his own expense will be required to take whatever measures may be required to correct this interference.

EVM Warnings and Restrictions

It is important to operate this EVM within the input voltage range of 90 VAC to 135 VAC and the output voltage range of 26 VDC to 34 VDC.

Exceeding the specified input range may cause unexpected operation and/or irreversible damage to the EVM. If there are questions concerning the input range, please contact a TI field representative prior to connecting the input power.

Applying loads outside of the specified output range may result in unintended operation and/or possible permanent damage to the EVM. Please consult the EVM User's Guide prior to connecting any load to the EVM output. If there is uncertainty as to the load specification, please contact a TI field representative.

During normal operation, some circuit components may have case temperatures greater than 90°C. The EVM is designed to operate properly with certain components above 90°C as long as the input and output ranges are maintained. These components include but are not limited to linear regulators, switching transistors, pass transistors, and current sense resistors. These types of devices can be identified using the EVM schematic located in the EVM User's Guide. When placing measurement probes near these devices during operation, please be aware that these devices may be very warm to the touch.

IMPORTANT NOTICE

Texas Instruments Incorporated and its subsidiaries (TI) reserve the right to make corrections, modifications, enhancements, improvements, and other changes to its products and services at any time and to discontinue any product or service without notice. Customers should obtain the latest relevant information before placing orders and should verify that such information is current and complete. All products are sold subject to TI's terms and conditions of sale supplied at the time of order acknowledgment.

TI warrants performance of its hardware products to the specifications applicable at the time of sale in accordance with TI's standard warranty. Testing and other quality control techniques are used to the extent TI deems necessary to support this warranty. Except where mandated by government requirements, testing of all parameters of each product is not necessarily performed.

TI assumes no liability for applications assistance or customer product design. Customers are responsible for their products and applications using TI components. To minimize the risks associated with customer products and applications, customers should provide adequate design and operating safeguards.

TI does not warrant or represent that any license, either express or implied, is granted under any TI patent right, copyright, mask work right, or other TI intellectual property right relating to any combination, machine, or process in which TI products or services are used. Information published by TI regarding third-party products or services does not constitute a license from TI to use such products or services or a warranty or endorsement thereof. Use of such information may require a license from a third party under the patents or other intellectual property of the third party, or a license from TI under the patents or other intellectual property of TI.

Reproduction of TI information in TI data books or data sheets is permissible only if reproduction is without alteration and is accompanied by all associated warranties, conditions, limitations, and notices. Reproduction of this information with alteration is an unfair and deceptive business practice. TI is not responsible or liable for such altered documentation. Information of third parties may be subject to additional restrictions.

Resale of TI products or services with statements different from or beyond the parameters stated by TI for that product or service voids all express and any implied warranties for the associated TI product or service and is an unfair and deceptive business practice. TI is not responsible or liable for any such statements.

TI products are not authorized for use in safety-critical applications (such as life support) where a failure of the TI product would reasonably be expected to cause severe personal injury or death, unless officers of the parties have executed an agreement specifically governing such use. Buyers represent that they have all necessary expertise in the safety and regulatory ramifications of their applications, and acknowledge and agree that they are solely responsible for all legal, regulatory and safety-related requirements concerning their products and any use of TI products in such safety-critical applications, notwithstanding any applications-related information or support that may be provided by TI. Further, Buyers must fully indemnify TI and its representatives against any damages arising out of the use of TI products in such safety-critical applications.

TI products are neither designed nor intended for use in military/aerospace applications or environments unless the TI products are specifically designated by TI as military-grade or "enhanced plastic." Only products designated by TI as military-grade meet military specifications. Buyers acknowledge and agree that any such use of TI products which TI has not designated as military-grade is solely at the Buyer's risk, and that they are solely responsible for compliance with all legal and regulatory requirements in connection with such use.

TI products are neither designed nor intended for use in automotive applications or environments unless the specific TI products are designated by TI as compliant with ISO/TS 16949 requirements. Buyers acknowledge and agree that, if they use any non-designated products in automotive applications, TI will not be responsible for any failure to meet such requirements.

Following are URLs where you can obtain information on other Texas Instruments products and application solutions:

Products

Audio	www.ti.com/audio
Amplifiers	amplifier.ti.com
Data Converters	dataconverter.ti.com
DLP® Products	www.dlp.com
DSP	dsp.ti.com
Clocks and Timers	www.ti.com/clocks
Interface	interface.ti.com
Logic	logic.ti.com
Power Mgmt	power.ti.com
Microcontrollers	microcontroller.ti.com
RFID	www.ti-rfid.com
OMAP Mobile Processors	www.ti.com/omap
Wireless Connectivity	www.ti.com/wirelessconnectivity

Applications

Automotive and Transportation	www.ti.com/automotive
Communications and Telecom	www.ti.com/communications
Computers and Peripherals	www.ti.com/computers
Consumer Electronics	www.ti.com/consumer-apps
Energy and Lighting	www.ti.com/energy
Industrial	www.ti.com/industrial
Medical	www.ti.com/medical
Security	www.ti.com/security
Space, Avionics and Defense	www.ti.com/space-avionics-defense
Video and Imaging	www.ti.com/video

TI E2E Community Home Page

e2e.ti.com

Mailing Address: Texas Instruments, Post Office Box 655303, Dallas, Texas 75265
Copyright © 2012, Texas Instruments Incorporated



Компания «ЭлектроПласт» предлагает заключение долгосрочных отношений при поставках импортных электронных компонентов на взаимовыгодных условиях!

Наши преимущества:

- Оперативные поставки широкого спектра электронных компонентов отечественного и импортного производства напрямую от производителей и с крупнейших мировых складов;
- Поставка более 17-ти миллионов наименований электронных компонентов;
- Поставка сложных, дефицитных, либо снятых с производства позиций;
- Оперативные сроки поставки под заказ (от 5 рабочих дней);
- Экспресс доставка в любую точку России;
- Техническая поддержка проекта, помощь в подборе аналогов, поставка прототипов;
- Система менеджмента качества сертифицирована по Международному стандарту ISO 9001;
- Лицензия ФСБ на осуществление работ с использованием сведений, составляющих государственную тайну;
- Поставка специализированных компонентов (Xilinx, Altera, Analog Devices, Intersil, Interpoint, Microsemi, Aeroflex, Peregrine, Syfer, Eurofarad, Texas Instrument, Miteq, Cobham, E2V, MA-COM, Hittite, Mini-Circuits, General Dynamics и др.);

Помимо этого, одним из направлений компании «ЭлектроПласт» является направление «Источники питания». Мы предлагаем Вам помощь Конструкторского отдела:

- Подбор оптимального решения, техническое обоснование при выборе компонента;
- Подбор аналогов;
- Консультации по применению компонента;
- Поставка образцов и прототипов;
- Техническая поддержка проекта;
- Защита от снятия компонента с производства.



Как с нами связаться

Телефон: 8 (812) 309 58 32 (многоканальный)

Факс: 8 (812) 320-02-42

Электронная почта: org@eplast1.ru

Адрес: 198099, г. Санкт-Петербург, ул. Калинина, дом 2, корпус 4, литера А.