



The engineer's choice

ebmpapst

614 J/2HHPR-010

INDEX

1	General	3
2	Mechanics	3
2.1	General	3
2.2	Connections	3
3	Operating Data	4
3.1	Operating Data - Electrical Interface - Input	4
3.2	Electrical Operating Data	5
3.3	Operating Data - Electrical Interface -Output	5
3.4	Electrical Features	6
3.5	Aerodynamic	7
3.6	Sound Data	7
4	Environment	8
4.1	General	8
4.2	Climatic requirements*).....	8
5	Safety	9
5.1	Electrical Safety	9
5.2	Approval Tests	9

1 General

Fan type	Fan	
Rotational direction looking at rotor	clockwise	
Airflow direction	Air outlet over struts	
Bearing system	Ball bearing	
Mounting position	any	

2 Mechanics

2.1 General

Width	60,0 mm	
Height	60,0 mm	
Depth	32,0 mm	
Weight	0,100 kg	
Housing material	Plastic	
Impeller material	Plastic	

2.2 Connections

Electrical connection	Wires	
Length of lead wire	400 mm	
Tolerance	+/- 10,0 mm	
Wire gauge (AWG)	24	
Insulation diameter	1,45 mm	

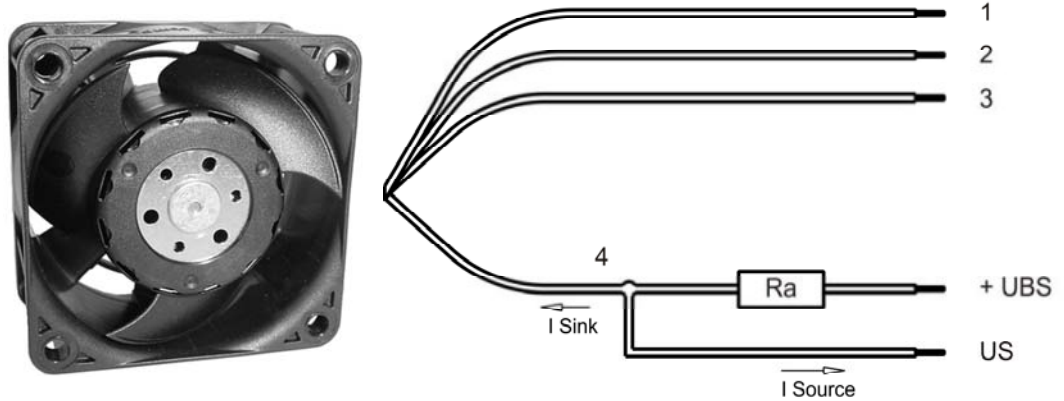

	Colour	Operation
Wire 1	red	+ UB
Wire 2	blue	- GND
Wire 3	black	PWM
Wire 4	white	Tacho

The auxiliaries shown on the schematic diagram (which are required for the intended use) are not part of our delivery.

3 Operating Data

3.1 Operating Data - Electrical Interface - Input

Control input	PWM
---------------	-----

Features

Input type	Open collector	
PWM - Frequency		1 kHz - 30 kHz Typical: 5 kHz

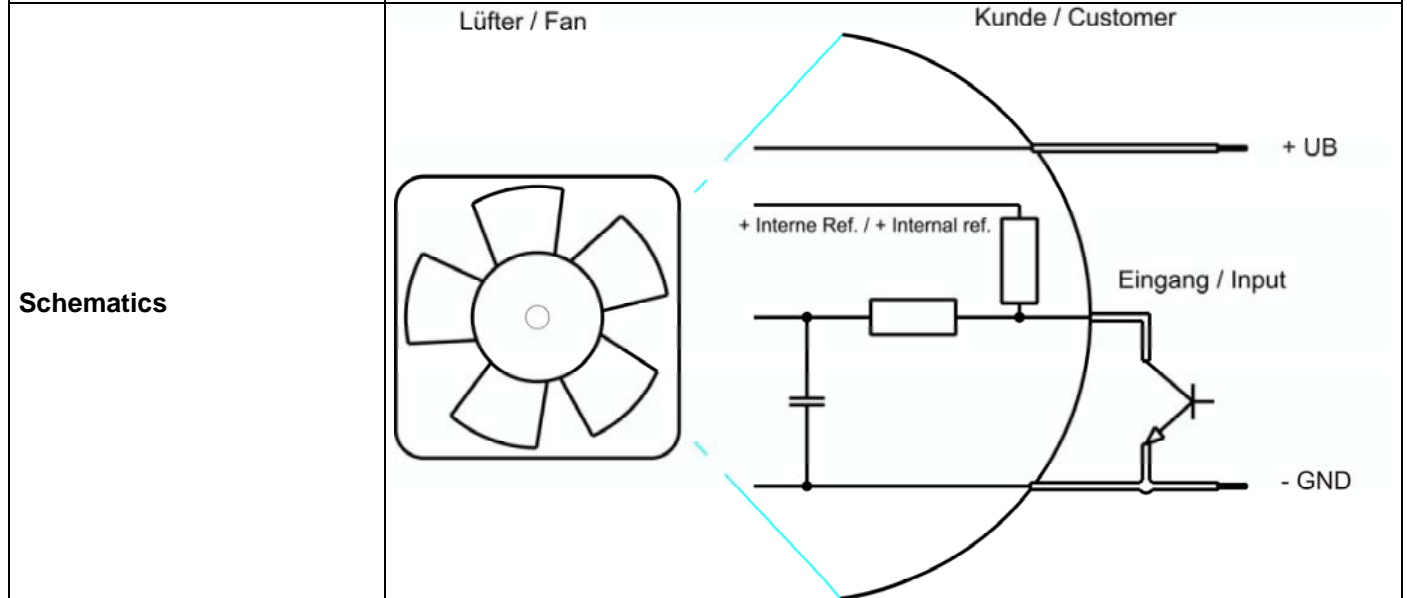
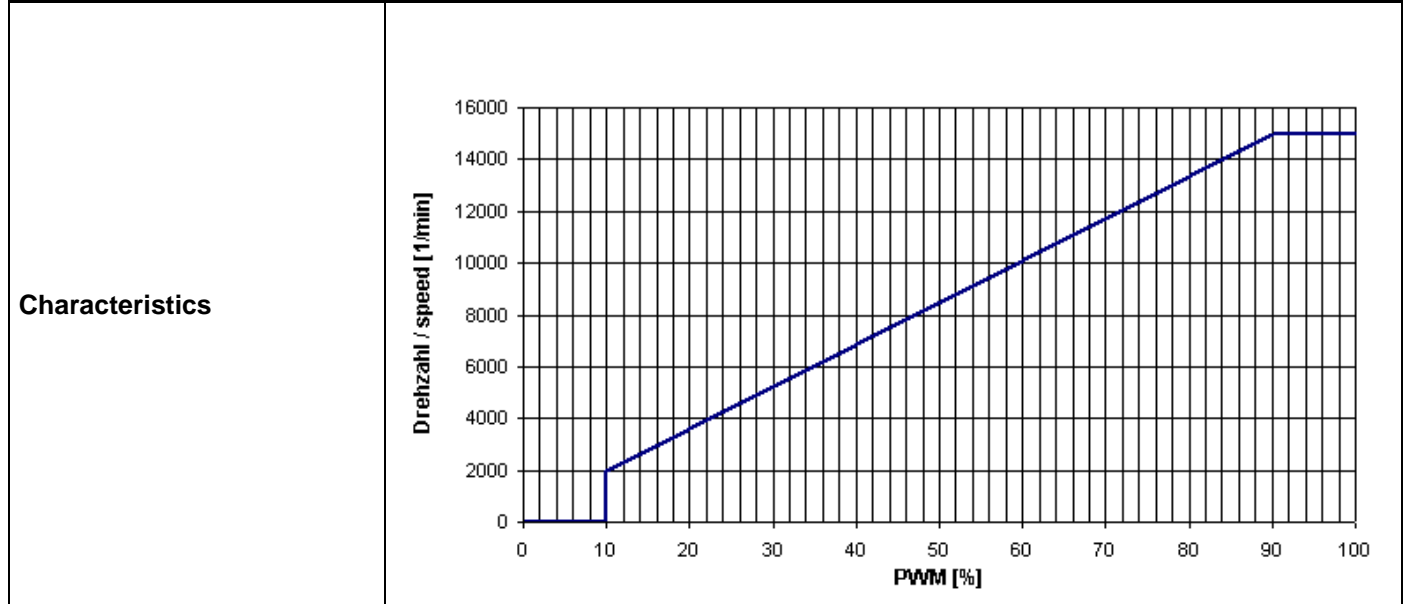

3.2 Electrical Operating Data

Measurement conditions: Normal air density = 1,2 kg/m³; Temperature 23°C +/- 3°C; Motor axis horizontal; warm-up time before measuring 5 minutes (unless otherwise specified). In the intake and outlet area should not be any solid obstruction within 0,5 m.

Δp = 0: corresp. to free air flow (see section 3.5)
 I: corresp. to arithm. mean current value

Name	Condition		
PWM 0001	PWM: 95 %;	f: 1 kHz	f: 30 kHz

Features	Condition	Symbol	Values		
Voltage range	Δp = 0	U	18,0 V		30,0 V
Nominal voltage	Δp = 0	U _N		24,0 V	
Power consumption	Δp = 0	P	7,5 W +/- 17,5 %	14,2 W +/- 25,0 %	14,7 W +/- 25,0 %
Tolerance	PWM 0001				
Current consumption	Δp = 0	I	415 mA +/- 17,5 %	590 mA +/- 25,0 %	490 mA +/- 25,0 %
Tolerance	PWM 0001				
Speed	Δp = 0	n	11.900 1/min +/- 12,5 %	15.000 1/min +/- 6,0 %	15.000 1/min +/- 6,0 %
Tolerance	PWM 0001				
Starting current consumption				2.000 mA	

3.3 Operating Data - Electrical Interface -Output

Tacho type	/2 (Open collector)
------------	---------------------

Signal-Ausgangsspannung / Signal output voltage

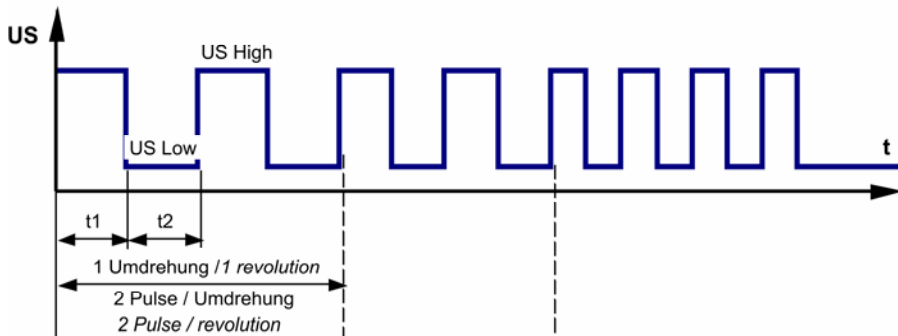

$$R_a = \frac{U_{BS} - U_{S \text{ Low}}}{I_{\text{Sink}}}$$

Lüfter-Drehzahl / Fan speed

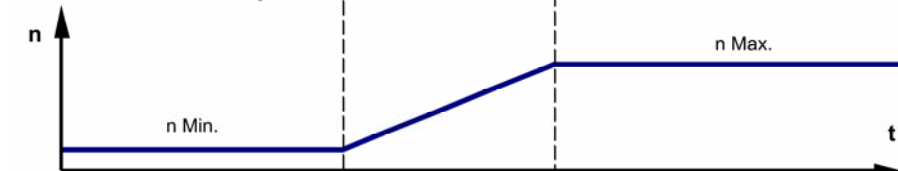

Features	Note	Values
Tacho operating voltage (UBS)		<= 60 V
Tacho signal Low	I sink: 2 mA	<= 0,4 V
Tacho signal High	I source: 0 mA	<= 60 V
Maximum sink current		<= 20 mA

External resistor	External resistor Ra from UBS to US required. All voltages measured to GND.	
Tacho frequency	$(2 \times n) / 60$	
Tacho isolated from motor	No	
Slew rate		=> 0,5 V/us

Alarm type	None
------------	------

3.4 Electrical Features

Electronic function	Speed-Controlled	
Reversed polarity protection	Rectifying diode	
Max. residual current at Un	IF <= 2 mA	
Locked rotor protection	Auto restart	
Locked rotor current at Un	approx. 1.650 mA	
Clock signal t3/t4 at locked rotor	Typical: 0,3 s / 5,3 s	

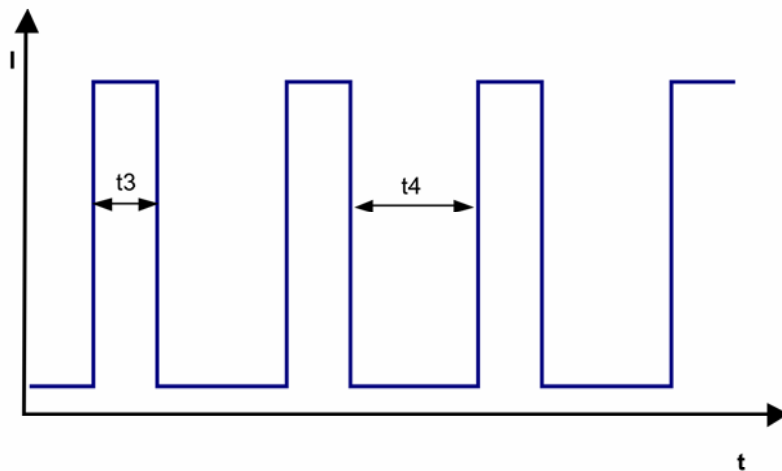

3.5 Aerodynamic

Measurement conditions: Measured with a double chamber intake rig acc. to DIN EN ISO 5801.
 Normal air density = 1,2 kg/m³; Temperature 23°C +/- 3°C;
 In the intake and outlet area should not be any solid obstruction within 0,5 m.

a.) Operation condition:

15.000 1/min at free air flow	PWM 95 %;	f: 1 kHz	f: 30 kHz
-------------------------------	-----------	----------	-----------

Max. free-air flow ($\Delta p = 0 / \dot{V} = \max.$)	83,0 m ³ /h	
Max. static pressure ($\Delta p = \max. / \dot{V} = 0$)	570 Pa	

3.6 Sound Data

Measurement conditions: Sound pressure level: 1 Meter distance between microphone and the air intake.
 Sound power level: Acc. to DIN 45635 part 38 (ISO 10302)
 Measured in a semianchoic chamber with a background noise level of Lp(A) < 5 dB(A)
 For further measurement conditions see section 3.5

a.) Operation condition:

15.000 1/min at free air flow	PWM 95 %	PWM min.: ; f: 1 kHz	PWM max.:; f: 30 kHz
-------------------------------	----------	----------------------	----------------------

Optimal operating point	75,0 m ³ /h @ 121 Pa	
Sound power level at the optimal operating point	7,6 bel(A)	
Sound pressure level at free air flow, measured in rubber bands	62,0 dB(A)	

4 Environment

4.1 General

Min. permitted ambient temperature TU min.	-40 °C	
Max. permitted ambient temperature TU max.	78 °C	
Min. permitted storage temperature TL min.	-40 °C	
Max. permitted storage temperature TL max.	80 °C	

for start up conditions ambient temperature has to be > -20°C

4.2 Climatic requirements*)

Humidity requirements	humid heat, cyclic; according to DIN EN 60068-2-30, 6 cycle	
Water exposure	None	
Radiation exposure	None	
Dust requirements	Dust check; according to DIN EN 60068-2-68, 6g/m2d, 1 day	
Salt fog requirements	None	
Harmful gas requirements	None	

*) Permitted application area:

The product is for the use in sheltered rooms with limited controlled temperature. Occasionally condensed water is allowed. Direct exposure to water must be avoided. Saline ambient conditions must be avoided.

Pollution degree 2 (according DIN EN 60664-1)

It occurs only non-conductive pollution. Occasionally, temporary conductivity caused by condensation occurs.

5 Safety

5.1 Electrical Safety

Dielectric strength DIN EN 60950 (VDE 0805) and DIN EN 60335 (VDE 0700) A.) Type test Measuring conditions: After 48h of storage at 95% R.H. and 25°C. No arcing or breakdown is allowed! All connections together to ground.	500 VAC / 1 Min.	
B.) Routine test Measuring conditions: At indoor climate. No arcing or breakdown is allowed! All connections together to ground.	500 VAC / 1 Sec.	
Isolation resistance Measuring conditions: After 48h of storage at 95% R.H. and 25°C measured with U=500 VDC for 1 min.	RI > 10 MOhm	
Air and leakage distances	1,0 mm / 1,2 mm	
Protection class	III	

5.2 Approval Tests

CE	Yes
UL	Yes / UL507, Electric Fans
VDE	Yes / Approval acc. to EN 60950 (VDE 0805) - Information technology equipment
CSA	No
CCC	No

The approval tests are observed to:

Maximal permitted operating voltage (see section 3.1) and max. permitted ambient temperature TU max.

Copy of this document, and printing it, shall not be an authorization of the contents thereof. Its
 provision shall remain entirely unaffected. Offenders are liable to the payment of fines. All rights are reserved.
 In the event of the grant of a patent or the registration of a utility model or design.

Spezialmodell nach DIN EN 60113 (Ausgabe 1
 bitte für praktische Maße DIN EN 60113-1

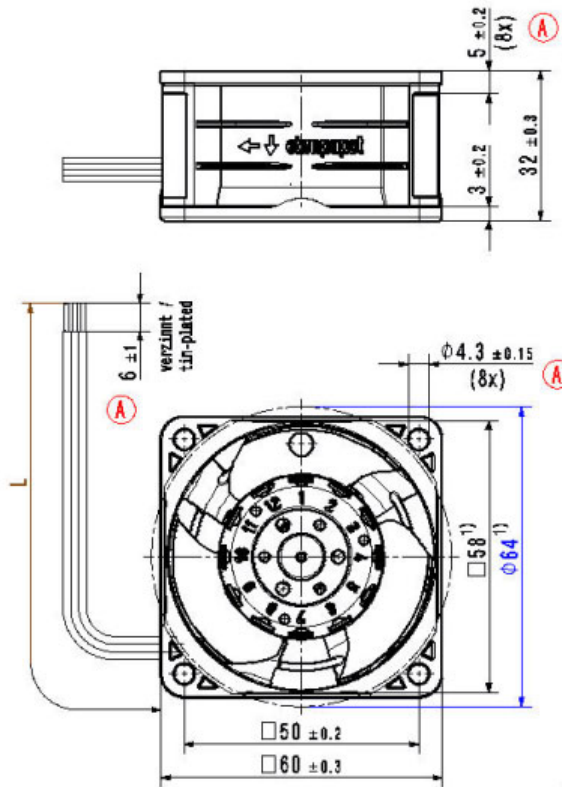

- 1.) Maße für Montagewand
 - Anzahl und Länge der Litzen siehe Produktspezifikation
 - Kein Axialspiel bei Kugellager durch Federausgleich
- 1.) Dimensions for worktop mounting
 - Number and length of the wires see product specification
 - No axial clearance in ball bearings by spring compensation

09-Instanz/State April-Wr./ State-yr.		0424-System-Version/ 0424 System-Version		00-Regional/ 00-Region		Werkstoff / Material: Volumen / Volume (m³):	
		BEZUGSWERT CIPROVA 30-Referenzmodell / 30-Reference model Datum Name				Artikel / Title: Zeichn.-Nr. / Drawing no.:	
Tolerierung / Tolerances: Allgemeine Tolerenzen / Res. Tolerances:		Werkz./ Draw. Zeichn./ Drawing Stückl./ Qty.		00-Referenzmodell / 30-Reference model Datum Name		Art.-f./Coll. / No. Name: Form- / Size: Material/Stück 1:2	
				Dokument- / Type of Document		Zeichnung / (Title/Title)	
		abe-papst Dr. Georgier GmbH & Co KG		Index / Index		Form- / Size: Material/Stück 1:2	



Компания «ЭлектроПласт» предлагает заключение долгосрочных отношений при поставках импортных электронных компонентов на взаимовыгодных условиях!

Наши преимущества:

- Оперативные поставки широкого спектра электронных компонентов отечественного и импортного производства напрямую от производителей и с крупнейших мировых складов;
- Поставка более 17-ти миллионов наименований электронных компонентов;
- Поставка сложных, дефицитных, либо снятых с производства позиций;
- Оперативные сроки поставки под заказ (от 5 рабочих дней);
- Экспресс доставка в любую точку России;
- Техническая поддержка проекта, помощь в подборе аналогов, поставка прототипов;
- Система менеджмента качества сертифицирована по Международному стандарту ISO 9001;
- Лицензия ФСБ на осуществление работ с использованием сведений, составляющих государственную тайну;
- Поставка специализированных компонентов (Xilinx, Altera, Analog Devices, Intersil, Interpoint, Microsemi, Aeroflex, Peregrine, Syfer, Eurofarad, Texas Instrument, Miteq, Cobham, E2V, MA-COM, Hittite, Mini-Circuits, General Dynamics и др.);

Помимо этого, одним из направлений компании «ЭлектроПласт» является направление «Источники питания». Мы предлагаем Вам помощь Конструкторского отдела:

- Подбор оптимального решения, техническое обоснование при выборе компонента;
- Подбор аналогов;
- Консультации по применению компонента;
- Поставка образцов и прототипов;
- Техническая поддержка проекта;
- Защита от снятия компонента с производства.



Как с нами связаться

Телефон: 8 (812) 309 58 32 (многоканальный)

Факс: 8 (812) 320-02-42

Электронная почта: org@eplast1.ru

Адрес: 198099, г. Санкт-Петербург, ул. Калинина, дом 2, корпус 4, литера А.