



User manual

UM EN THERMOMARK ROLL

Thermal Transfer Printer for Labels and
Continuous Media

User manual

Thermal Transfer Printer for Labels and Continuous Media

2012-04-13

Designation: UM EN THERMOMARK ROLL

Version: 03

Order No.: –

This user manual is valid for:

Designation	Order no.
THERMOMARK ROLL	5146477
THERMOMARK ROLL AR	5146749
THERMOMARK ROLL X1	5146723

General terms and conditions of use for technical documentation

Phoenix Contact reserves the right to alter, correct, and/or improve the technical documentation and the products described in the technical documentation at its own discretion and without giving prior notice, insofar as this is reasonable for the user. The same applies to any technical changes that serve the purpose of technical progress.

The receipt of technical documentation (in particular user documentation) does not constitute any further duty on the part of Phoenix Contact to furnish information on modifications to products and/or technical documentation. You are responsible to verify the suitability and intended use of the products in your specific application, in particular with regard to observing the applicable standards and regulations. All information made available in the technical data is supplied without any accompanying guarantee, whether expressly mentioned, implied or tacitly assumed.

In general, the provisions of the current standard Terms and Conditions of Phoenix Contact apply exclusively, in particular as concerns any warranty liability.

This manual, including all illustrations contained herein, is copyright protected. Any changes to the contents or the publication of extracts of this document is prohibited.

Phoenix Contact reserves the right to register its own intellectual property rights for the product identifications of Phoenix Contact products that are used here. Registration of such intellectual property rights by third parties is prohibited.

Other product identifications may be afforded legal protection, even where they may not be indicated as such.

How to contact us

Internet

Up-to-date information on Phoenix Contact products and our Terms and Conditions can be found on the Internet at:

www.phoenixcontact.com

Make sure you always use the latest documentation.

It can be downloaded at:

www.phoenixcontact.net/catalog

Subsidiaries

If there are any problems that cannot be solved using the documentation, please contact your Phoenix Contact subsidiary.

Subsidiary contact information is available at www.phoenixcontact.com.

Published by

PHOENIX CONTACT GmbH & Co. KG
Flachsmarktstraße 8
32825 Blomberg
GERMANY

Should you have any suggestions or recommendations for improvement of the contents and layout of our manuals, please send your comments to:

tecdoc@phoenixcontact.com

Note on the print media

The result of the print depends essentially on the suitable combination of material and print ribbon.









NOTE: Use suitable print media

A low-quality ink ribbon can lead to premature wear on the printhead and result in a poor print image. Use only print media from Phoenix Contact.

You can find suitable print media in the Phoenix Contact catalog.

Change language of Touch Screen

The language of the Touch Screen is set to English by default. To select a different language, proceed as follows:

- Touch  to open the menu.
- Select  then for the settings.
- With , you access the regional settings.
- Touch the  symbol.
- Use the horizontal arrows to select your language.
- Confirm your selection with .
- Touch  to return to the menu.

Technical data

	THERMOMARK ROLL THERMOMARK ROLL AR	THERMOMARK ROLL X1
Resolution	300 dpi x 300 dpi (12 points/mm x 12 points/mm)	300 dpi x 300 dpi (12 points/mm x 12 points/mm)
Print mode	Thermal transfer, thermal direct	Thermal transfer, thermal direct
CPU	32 Bit/400 MHz	32 Bit/400 MHz
Material sensor		
Position	Center	Center
Type	Gap sensor	Gap sensor
Detection	Label gap, black mark and punch-hole mark	Label gap, black mark and punch-hole mark
Print speed	30 mm/s ... 125 mm/s	30 mm/s ... 125 mm/s
Print length	At least 5 mm, maximum 1000 mm	At least 5 mm, maximum 1000 mm
Print width	Maximum 104 mm	Maximum 104 mm
Print medium		
Outside diameter of the roll of labels	Maximum 152 mm	Maximum 205 mm
Internal core diameter	38.1 mm ... 76 mm	38.1 mm ... 76 mm
Ink ribbon		
Length	Maximum 300 m	Maximum 300 m
Outside diameter of the ink ribbon reel	Maximum 68 mm	Maximum 68 mm
Internal core diameter	25.4 mm	25.4 mm
Ink side	Outside	Outside
Interfaces	USB 2.0, Full speed slave, Ethernet 10/100Base-T 1 x USB master, 500 mA (back side)	USB 2.0, Full speed slave, Ethernet 10/100Base-T 1 x USB master, 500 mA (back side) 2 x USB master, 100 mA (front side)
Display and Operation	Touch display with 160 x 255 pixels, 96.31 mm diagonal	Touch display with 160 x 255 pixels, 96.31 mm diagonal
Voltage	100 V AC ... 240 V AC, 50/60 Hz, PFC	100 V AC ... 240 V AC, 50/60 Hz, PFC
Power	Maximal 100 W	Maximal 100 W
Temperature		
Operation	+5 °C ... +35 °C	+5 °C ... +35 °C
Bearings	0 °C ... +60 °C	0 °C ... +60 °C
Transport	-25 °C ... +60 °C	-25 °C ... +60 °C
Humidity		
Operation	10 % ... 85 %, not condensing	10 % ... 85 %, not condensing
Bearings	20 % ... 80 %, not condensing	20 % ... 80 %, not condensing
Transport	20 % ... 80 %, not condensing	20 % ... 80 %, not condensing

THERMOMARK ROLL

Technical data

	THERMOMARK ROLL THERMOMARK ROLL AR	THERMOMARK ROLL X1
Approvals	5146477: CE, FCC class A, UL, CB 5146749: CE, FCC class A, UL, CB, S-Mark	5146723: CE, FCC class A, UL, CB
Dimensions (H x D x W)	189 mm x 320 mm x 253 mm	245 mm x 412 mm x 264 mm
Weight	3.5 kg	5.0 kg
Optional extensions		
Cutter	THERMOMARK ROLL-CUTTER	THERMOMARK ROLL X1-CUTTER
Perforation cutter	THERMOMARK ROLL-CUTTER/P	THERMOMARK ROLL X1-CUTTER/P
Media hub	THERMOMARK ROLL-ERH	-

1	Introduction	8
1.1	Product Description	8
1.2	Instructions	8
1.3	Intended Use	9
1.4	Safety Instructions	9
1.5	Environment	10
2	Installation	11
2.1	Device Overview	11
2.2	Unpacking and Setting-up the Printer	14
2.3	Connecting the Device	15
2.3.1	Connecting to the Power Supply	15
2.3.2	Connecting to a Computer via USB	16
2.3.3	Connecting to a Network via Ethernet	16
2.4	Switching on the Device	17
3	Touchscreen Display	18
3.1	Structure of the Touchscreen Display	18
3.2	Operating the Touchscreen Display	18
3.3	Symbols on the Start Display	18
3.4	Printer States	19
3.5	Configure Ethernet Interface	20
3.6	Perform Test Print	20
4	Loading Material	21
4.1	Loading Continuous Media from Roll	21
4.2	Loading Fanfold Labels	22
4.3	Loading Transfer Ribbon	23
5	Option	25
5.1	Cutter/Perforation Cutter	25
5.2	External Supply Hub	26
6	Printing Operation	27
6.1	Printing in Tear-off Mode	27
6.2	Printing in Cutting Mode	27
7	Cleaning	28
7.1	Cleaning Instructions	28
7.2	Cleaning the Printhead	29
7.3	Cleaning or Replacing the Print Roller	30
7.4	Cleaning Cutter/Perforation Cutter and Replace Blades	31
8	Fault Correction	33
8.1	Problem Solution	33
8.2	Error Messages and Fault Correction	34
9	Licences	36
9.1	EC Declaration of Conformity	36
9.2	FCC	38
9.3	GPL Code Statement	38
10	Index	39

1.1 Product Description

The device is an industrial thermal transfer printer for printing labels and continuous media.

1.2 Instructions

Important information and instructions in this documentation are designated as follows:



Danger!

Draws your attention to an exceptionally grave, impending danger to your health or life.



Warning!

Indicates a hazardous situation that could lead to injuries or material damage.



Attention!

Draws attention to possible dangers, material damage or loss of quality.



Notice!

Gives you tips. They make a working sequence easier or draw attention to important working processes.



Environment!

Gives you tips on protecting the environment.



Handling instruction



Reference to section, position, illustration number or document.



Option (accessories, peripheral equipment, special fittings).

Zeit Information in the display.

1.3 Intended Use

- The device is manufactured in accordance with the current technological status and the recognized safety rules. However, danger to the life and limb of the user or third parties and/or damage to the device and other tangible assets can arise during use.
- The device may only be used for its intended purpose and if it is in perfect working order, and it must be used with regard to safety and dangers as stated in the operating manual.
- The device printer is intended exclusively for printing suitable materials. Any other use or use going beyond this shall be regarded as improper use. The manufacturer/supplier shall not be liable for damage resulting from unauthorized use; the user shall bear the risk alone.
- Usage for the intended purpose also includes complying with the operating manual, including the manufacturer's maintenance recommendations and specifications.

Notice!



The complete documentation is included in the scope of delivery on DVD, and can also currently be found in the Internet.

1.4 Safety Instructions

- The device is configured for voltages of 100 to 240 V AC. It only has to be plugged into a grounded socket.
- Only connect the device to other devices which have a protective low voltage.
- The device may only be used in a dry environment, do not expose it to moisture (sprays of water, mists, etc.).
- Do not use the device in an explosive atmosphere.
- Do not use the device close to high-voltage power lines.
- If the device is operated with the cover open, ensure that people's clothing, hair, jewelry etc. do not come into contact with the exposed rotating parts.
- The device or parts of it can become hot while printing. Do not touch during operation, and allow to cool down before changing material and before disassembly.
- Risk of crushing when closing the cover. Touch the cover at the outside only. Do not reach into the swivel range of the cover.
- Perform only those actions described in this operating manual. Work going beyond this may only be performed by trained personnel or service technicians.
- Unauthorized interference with electronic modules or their software can cause malfunctions.

- Other unauthorized work on or modifications to the device can also endanger operational safety.
- Always have service work done in a qualified workshop, where the personnel have the technical knowledge and tools required to do the necessary work.
- There are various warning stickers on the device. They draw your attention to dangers.
Warning stickers must therefore not be removed, as then you and other people cannot be aware of dangers and may be injured.
- The maximum sound pressure level is less than 70 dB(A).



Danger!

Danger to life and limb from power supply.

- ▶ **Do not open the device casing.**

1.5 Environment



Obsolete devices contain valuable recyclable materials that should be sent for recycling.

- ▶ Send to suitable collection points, separately from residual waste.

The modular construction of the printer enables it to be easily disassembled into its component parts.

- ▶ Send the parts for recycling.



The electronic circuit board of the device is equipped with a lithium battery.

- ▶ Take old batteries to collection boxes in shops or public waste disposal centers..

2.1 Device Overview

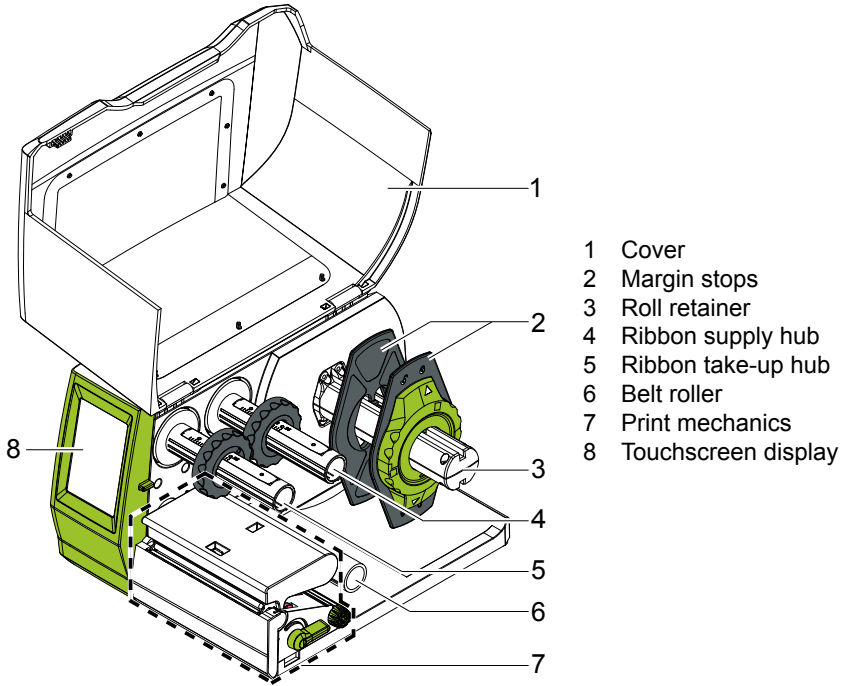

Fig. 1 THERMOMARK ROLL with Tear-off Plate

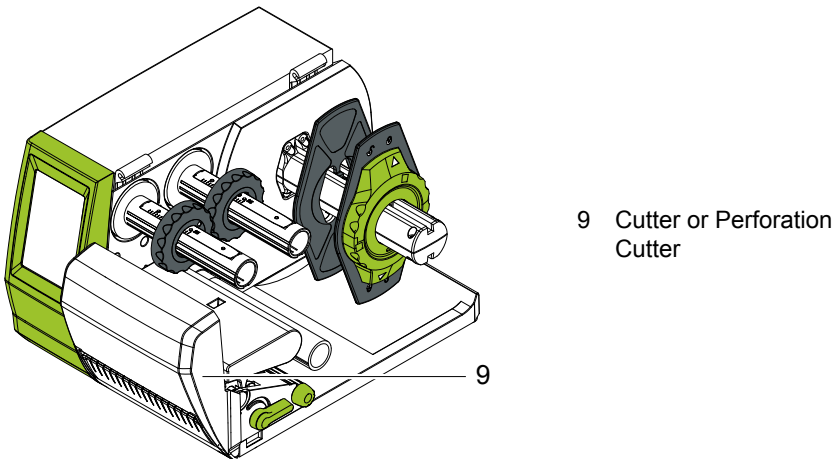

Fig. 2 THERMOMARK ROLL with Cutter or Perforation Cutter

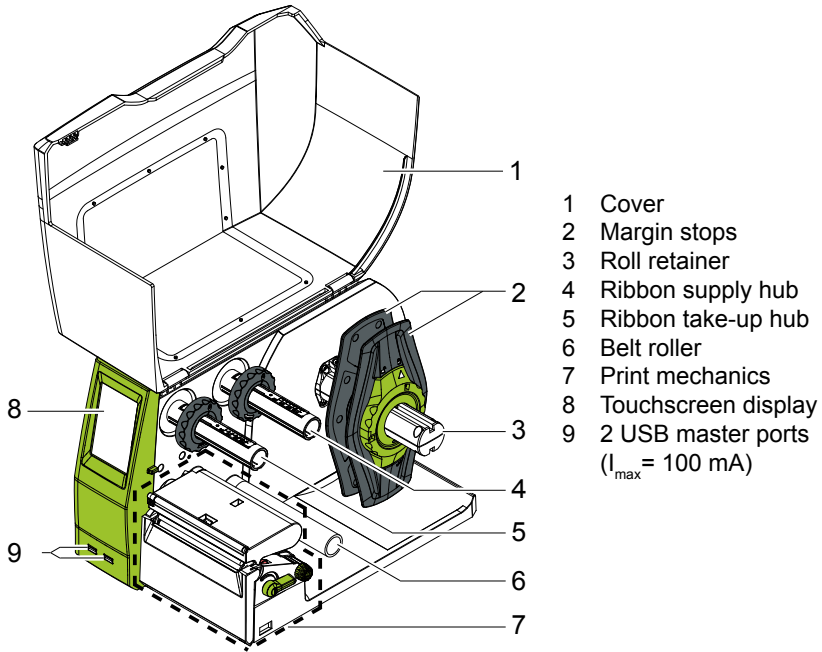

Fig. 3 THERMOMARK ROLL X1 with Tear-off Plate

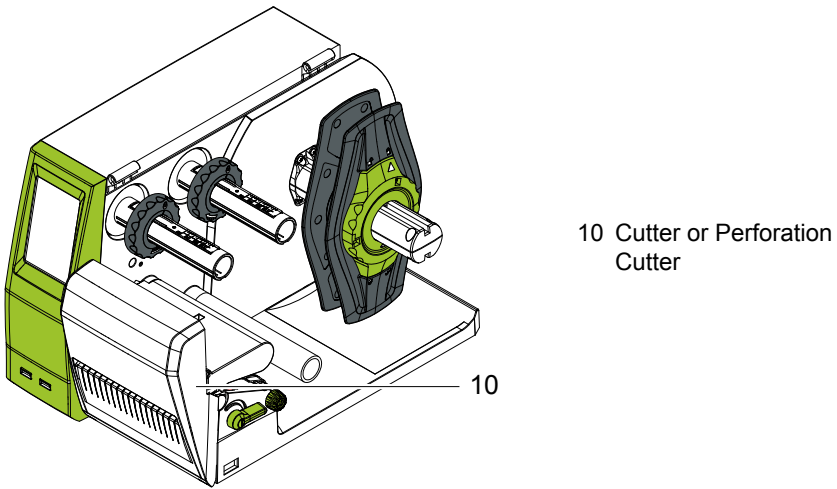

Fig. 4 THERMOMARK ROLL X1 with Cutter or Perforation Cutter

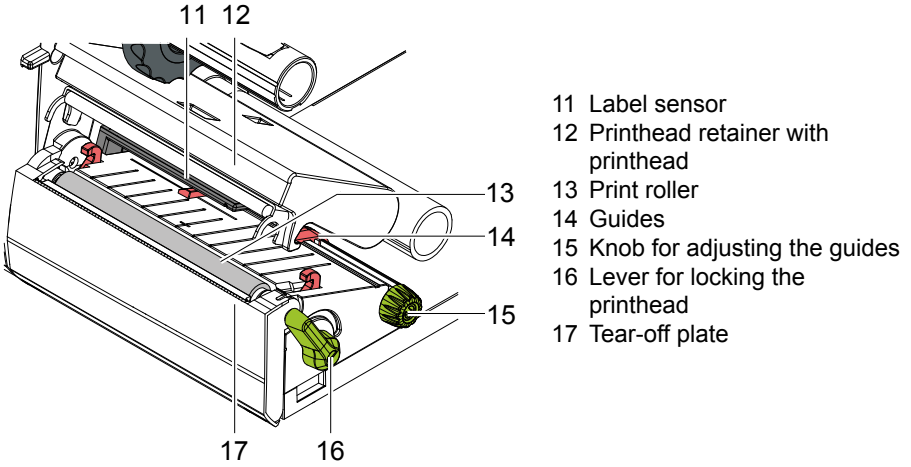

Fig. 5 Print Mechanics

2.2 Unpacking and Setting-up the Printer

- ▶ Lift the label printer out of the box and set it up on a level surface.
- ▶ Check label printer for damage which may have occurred during transport.
- ▶ Check delivery for completeness.

Contents of Delivery:

- Label Printer
- Power Cable Type E+F
- USB Cable
- Operator's Manual
- DVD with application software CLIP PROJECT, driver and documentation
- Transfer ribbon
- Continuous labels on roll



Notice!

Please keep the original packaging in case the printer must be returned.



Notice!

When transporting the printer remove the transfer ribbon and media.



Attention!

The device and printing materials will be damaged by moisture and wetness.

- ▶ **Set up label printers only in dry locations protected from splash water.**

2.3 Connecting the Device

Fig. 6 Connections

2.3.1 Connecting to the Power Supply

The printer is equipped with a wide area power unit for a supply voltage of 100 V to 240 V.

1. Check that the device is switched off.
2. Plug the power cable into the power connection jack (5).
3. Plug the power cable into a grounded socket.

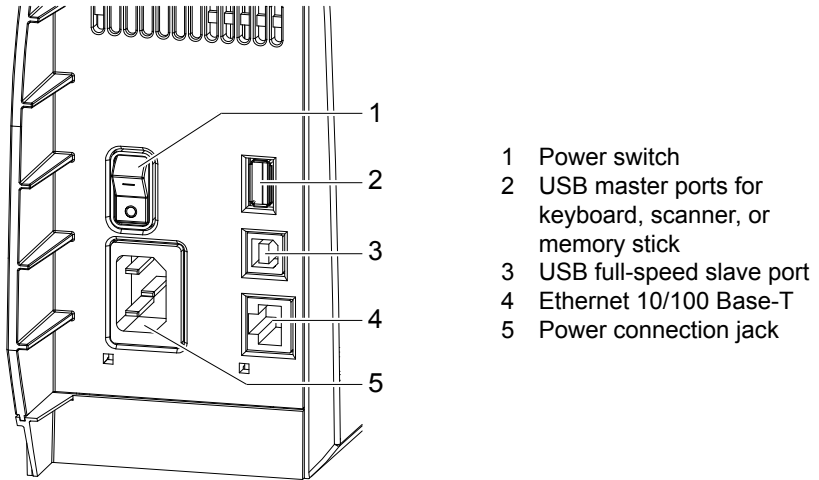
2.3.2 Connecting to a Computer via USB

**Attention!**

Inadequate or no grounding can cause malfunctions during operations.

- ▶ **Ensure that all computers and cables connected to the label printer are grounded.**

In order to connect the printer to a USB interface a printer driver must be installed. The adequate driver for your device can be found on the DVD included in the contents of delivery or on the internet at www.phoenixcontact.net/catalog.

- ▶ Switch on computer.
- ▶ Terminate all running tasks.
- ▶ Switch on THERMOMARK ROLL.
- ▶ Connect computer with THERMOMARK ROLL using the included USB cable.
- ▶ Insert DVD with the driver software into the DVD drive.
- ▶ The Windows installation wizard is started automatically.
- ▶ Follow the instructions on the screen.
- ▶ When the error message "Windows logo test failed" appears, still continue the installation.

After a successful installation an icon for the THERMOMARK ROLL appears in the windows system directory "Printer".

CLIP PROJECT

Afterwards, configure the THERMOMARK ROLL in the planning and marking software CLIP PROJECT in the module "Marking".

- ▶ Add the THERMOMARK ROLL as a new printer in CLIP PROJECT "Marking" under „File... configure output device...“.

2.3.3 Connecting to a Network via Ethernet

The integrated Ethernet interface allows the operation of the printer in a network. To connect the printer to a network outlet a patch cable with a RJ45 plug for 10Base or 100Base-T is necessary.

**Attention!**

When connecting the printer to the network a shielded cable must necessarily be used.

- ▶ Connect computer to a printer by a suitable cable.

2.4 Switching on the Device

When all connections have been made:

- ▶ Switch the printer on at the power switch (1).
The printer performs a system test, and then shows the system status `READY` in the touch-screen display.

If an error occurs during the system test, the symbol , `Critical fault` and type of error are displayed.

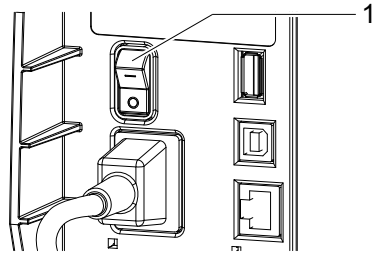
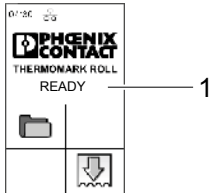

Fig. 7 Power Switch

3.1 Structure of the Touchscreen Display



The touchscreen display (1) indicates the current status of the printer and the print job, indicates faults and shows the printer settings in the menu.

By selecting the buttons on the touchscreen display (1) settings can be made.

Fig. 8 Touchscreen Display

3.2 Operating the Touchscreen Display

The touchscreen display is operated directly by touch:

- To open a menu or select a menu item lightly touch the corresponding symbol.
- To scroll in lists slide finger up or down on the display.

3.3 Symbols on the Start Display

Symbol	Status	Function
	Ready	To offline menu
	Error	
	Ready	Feeds a blank label
	Ready	After the end of a print job, reprint the last label
	Printing label	Interrupt print job, printer goes into "Pause" state
	Pause	Continue the print job, printer goes into "Printing label" state
	Error	
	Ready	Delete internal memory, the last label can no longer be reprinted.
	Printing label	Cancel current print job and delete all print jobs.
	Pause	
	Error	

Table 1 Symbols on the Start Display

3.4 Printer States











State	Display	Description
Ready	Ready and the symbols  and 	The printer is in the ready state and can receive data or print labels.
Ready (after first print)	Ready and the symbols  ,  and 	The printer is in the ready state and can receive data.
Printing Label	Label description and the number of the printed label in the print job and the symbols  and 	The printer is currently processing an active print job. Data can be transmitted for a new print job. The new print job will start when the previous one has finished.
Pause	Pause and the symbol 	The printing process has been interrupted by the operator.
Error	 Error and the type of error, the label description and the number of labels still to be printed	An error has occurred.
Critical error	 Critical fault and the type of error Display flashes red	An error occurs during the system test. ▶ Switch the printer off and then on again at the power switch. ▶ Call Service if the fault occurs persistently.
Power Save Mode		If the printer is not used for a lengthy period, it automatically switches to power save mode. ▶ To exit power save mode: Touch touchscreen display.

Table 2 Printer States

3.5 Configure Ethernet Interface





The Ethernet interface can be configured under menu item **Setup > Interfaces**.

The following parameters are necessary for operating the printer in a network. Contact your network administrator if required.

- IP address
- Subnet mask
- if necessary gateway

Alternatively, the Ethernet configuration is also available via DHCP server. In this case, make sure that the transmitted configuration is always the same.

Configure Ethernet interface at the printer

- ▶ Select  .
- ▶ Select **Setup**.
- ▶ Select **Interfaces**.
- ▶ Select **Ethernet**.
- ▶ Select setting options.
- ▶ Select desired setting with ▶ ◀.
- ▶ Confirm selection with  or cancel selection with  .
- ▶ Return to start screen with  .

3.6 Perform Test Print

- ▶ Select  .
- ▶ Select **Test**.
- ▶ Select **EML**.
- ▶ Test print starts.

4.1 Loading Continuous Media from Roll

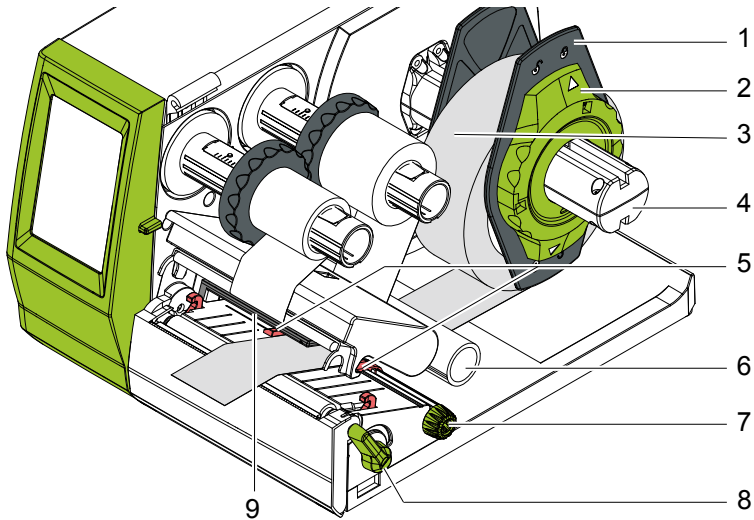



Fig. 9 Loading Continuous Media from Roll

1. Turn ring (2) counterclockwise, so that the arrows points to the symbol  and thus release the margin stop (1) from the roll retainer (4).
2. Load label roll (3) on the roll retainer (4) in such a way that the printing side of the labels is visible from above.
3. Re-mount the margin stop (1) and push against the label roll as far as possible.
4. Turn ring (2) clockwise, so that the arrow points to the symbol , and thus fix the margin stop(1) on the roll retainer (4).
5. Turn lever (8) counterclockwise to open printhead.
6. If the printer is equipped with a cutter or perforation cutter, fold it down.
7. Position guides (5) by turning the knob (7) so that they are several millimeters wider than the material.
8. Position material below the belt roller (6) and guide it through the print unit.

**Attention!**

► **Guide material through the print unit below the label sensor (9).**

9. Move guides (3) closely to the edges of the material without clamping the material.
10. If the printer is equipped with a cutter/perforation cutter, guide material through the cutter and fold cutter back to the printing unit.
11. Press printhead retainer down and turn lever (8) clockwise to lock the printhead.

4.2 Loading Fanfold Labels

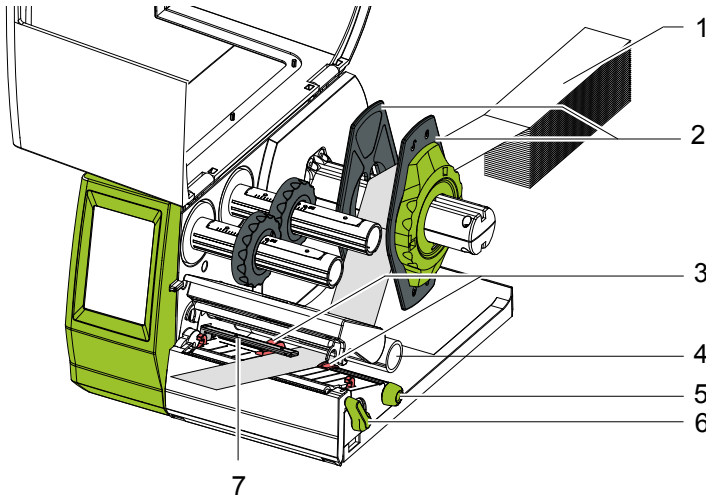

Fig. 10 Loading Fanfold Labels

1. Position label stack (1) behind the printer.
2. Guide material below the roll retainer (2) to the printing unit. Ensure that the printing side of the labels is visible from above.
3. Turn lever (6) counterclockwise to open printhead.
4. If the printer is equipped with a cutter or perforation cutter, fold it down.
5. Position guides (3) by turning the knob (5) so that they are several millimeters wider than the material.
6. Position material below the belt roller (4) and guide it through the print unit.

**Attention!**

► **Guide material through the print unit below the label sensor (7).**

7. Move guides (3) closely to the edges of the material without clamping the material.
8. If the printer is equipped with a cutter/perforation cutter, guide material through the cutter and fold cutter back to the printing unit.
9. Press printhead retainer down and turn lever (6) clockwise to lock the printhead.

4.3 Loading Transfer Ribbon

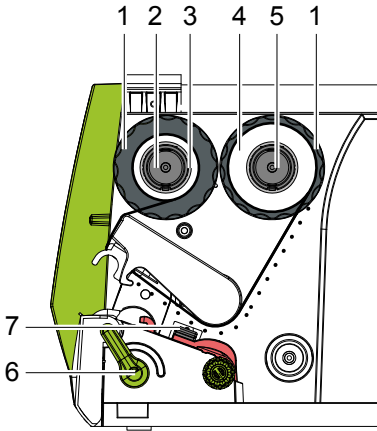

Fig. 11 Transfer Ribbon Feed Path

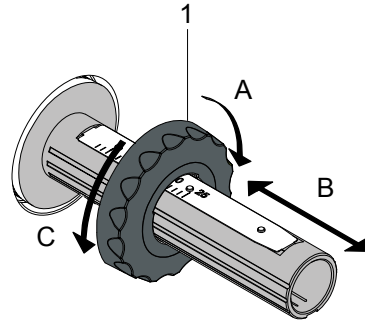

Fig. 12 Guide Adjustment

Notice!

With direct thermal printing, do not load a transfer ribbon; if one has already been loaded, remove it.

1. Clean the printhead before loading the transfer ribbon (▷ 7.2 on page 28).
2. Turn lever (6) counterclockwise to open the printhead.
3. Set guide (1) on both hubs to the correct transfer ribbon width (Fig. 12):
 - Hold hub and unlock guide (1) by turning it in direction A.
 - Slide guide in direction B and adjust guide to ribbon width using the scale.
 - Hold hub and lock guide by turning it in direction C.
4. Load transfer ribbon (4) on the hub (5) until it reaches the guide in a way that the color coating of the ribbon faces the opposite side of the printhead after being loaded.

Notice!

To wind the ribbon a ribbon core (3) is needed that must be at least equal in width to the supply ribbon.

▶ **When changing the transfer ribbon use the empty supply ribbon core for winding the next ribbon.**

5. Adjust position of the guide on the take-up hub to the width of the ribbon core (3) and push ribbon core on the take-up hub (2).
6. Guide transfer ribbon through the printing unit as shown in Fig. 9.

**Attention!**

▶ **Guide transfer ribbon over the label sensor (7).**

7. Secure starting end of the transfer ribbon to the ribbon core (3) using adhesive tape. Ensure counterclockwise rotation direction of the transfer ribbon take-up hub.
8. Turn transfer ribbon take-up hub (2) counterclockwise to smooth out the feed path of the transfer ribbon.
9. Press printhead down and turn lever (6) clockwise to lock printhead.

5.1 Cutter/Perforation Cutter

As an option a cutter (THERMOMARK ROLL-CUTTER, Art.-No.: 5146422, THERMOMARK ROLL-CUTTER X1, Art.-No.: 5146765), with which labels can be cut automatically is available. This cutter is also suitable for cutting endless labels.

For marking sleeves a perforation cutter (THERMOMARK ROLL-CUTTER/P, Art.-No.: 5146435, THERMOMARK ROLL-CUTTER/P X1, Art.-No.: 5146766) is available.

Dismount Tear-Off Plate

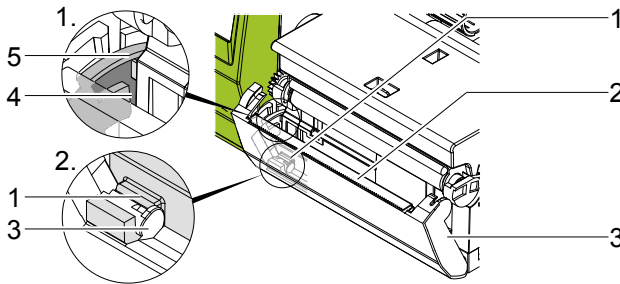

Fig. 13 Dismount tear-off plate

1. Fold down cover (3) with tear-off plate (2) until the slot (4) at the latch-hook (5) is visible.
2. Lift cover (3) from the retainer (1).

Mount Cutter/Perforation Cutter

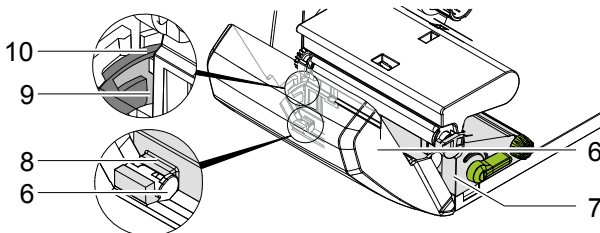

Fig. 14 Mount cutter/perforation cutter

3. First, put the latch-hook (10) of the cutter with the slot (9) into the guiding of the retainer (7).
4. Push cutter (6) down into the retainers (8) .
5. Fold up cutter (6) until it snaps in at both sides of the retainer (7).

5.2 External Supply Hub

As an option an external supply hub (THERMOMARK ROLL-ERH, Art.-No.: 5146448), with which media rolls with bigger diameters can be processed is available.

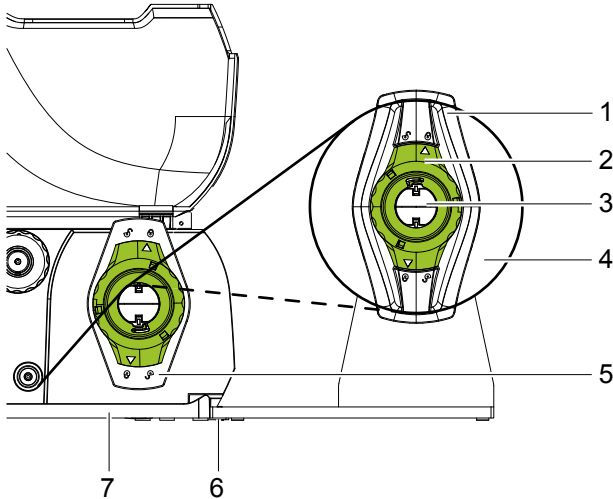



Fig. 15 Load Material to External Supply Hub

Mount External Supply Hub

1. Position External supply hub behind the printer.
2. Lift printer slightly and position ground plate (7) on both hooks (6) of the external supply hub.

Load Material

1. Turn ring (2), so that the arrows points to the symbol , and thus release the margin stop (1) from the roll retainer (3).
2. Load label roll (4) on the roll retainer (3) in such a way that the printing side of the labels is visible from above.
3. Re-mount the margin stop (1) and push against the label roll as far as possible.
4. Turn ring (2) clockwise, so that the arrow points to the symbol , and thus fix the margin stop (1) on the roll retainer (3).
5. Adjust guide (5) of the printer to the material width.
6. Guide material over roll retainer of the printer and load into printing unit (▷ 4.1 on page 21).



Attention!

Printhead damage caused by improper handling!

- ▶ **Do not touch the underside of the printhead with the fingers or sharp objects.**
- ▶ **Ensure that the labels are clean.**

The printer is ready for operation when all connections have been made and labels and the transfer ribbon have been loaded.

6.1 Printing in Tear-off Mode

After printing the label is torn-off manually. For this the printer is equipped with a tear-off plate.

6.2 Printing in Cutting Mode

The printer version with cutter or perforation cutter is used to cut off or perforate labels and endless material automatically after printing.



Notice!

The cutting mode must be activated in the software.

7.1 Cleaning Instructions



Danger!

Risk of death via electric shock!

- ▶ **Disconnect the printer from the power supply before performing any maintenance work.**

It is important to clean the thermal printhead regularly. This guarantees a consistently good printed image and reduces wear of the printhead.



Attention!

The printer can be damaged by aggressive cleansers.

- ▶ **Do not use abrasive cleaners or solvents for cleaning the external surfaces or modules.**
- ▶ Remove dust and paper fluff from the print area with a soft brush or vacuum cleaner.
- ▶ The cover of the printer can be cleaned with a standard cleanser.

7.2 Cleaning the Printhead

Cleaning intervals:

direct thermal printing - every media roll change

thermal transfer printing - every ribbon roll change

Substances may accumulate on the printhead during printing and adversely affect printing.



Attention!

Printhead can be damaged!

- ▶ Do not use sharp or hard objects to clean the printhead.
- ▶ Do not touch protective glass layer of the printhead.



Attention!

Risk of injury from the hot printhead line.

- ▶ Ensure that the printhead has cooled down before starting cleaning.

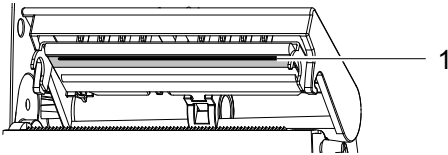

Fig. 16 Printhead Line

1. Lift the printhead.
2. Remove labels and transfer ribbon from the printer.
3. Clean printhead line (1) with rubbing alcohol and a soft cloth.
4. Allow printhead to dry for 2–3 minutes before commissioning the printer.

7.3 Cleaning or Replacing the Print Roller

Accumulations of dirt on the print roller may impair the media transport and the print quality.



Attention!

Damage of the print roller.

- ▶ Do not use sharp objects (knives, screwdrivers, etc.) to clean the printhead.



Notice!

When large amounts of narrow and thick media (10 mm profiles, narrow endless shrink sleeve) are used, the print roller might be deformed and a result in a worsened printing for labels.

After approximately 24 h the deformation will disappear.

For these applications two separate print rollers should be used for different labels.

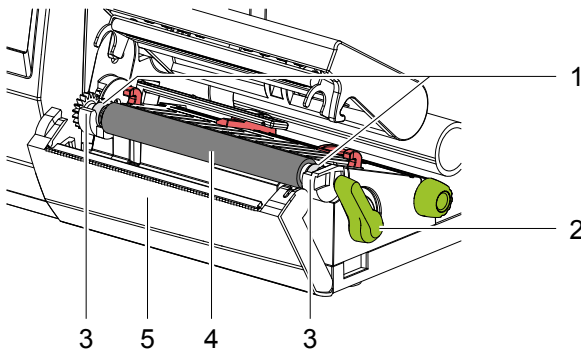

Fig. 17 Print Roller

1. Turn lever (2) counterclockwise to open printhead.
2. Remove material and transfer ribbon from the printer.
3. Fold down cover (5) with tear-off plate, cutter or perforation cutter.
4. Lift print roller (4) from its retainers (3).
5. Remove deposits with roller cleaner and a soft cloth, or replace it if the roller appears damaged.
6. Push roller with bearings (1) into the retainer (3) until they click into place.
7. Fold up cover (5) with tear-off plate, cutter or perforation cutter.

7.4 Cleaning Cutter/Perforation Cutter and Replace Blades

**Warning!**

- ▶ Disconnect printer from electrical outlet to prevent accidental blade movement.

**Warning!**

Risk of injury! The cutter blades are sharp!

**Notice!**

When cutting through the label material instead of the label gap remains of adhesive may accumulate on the blades. If operating in backfeed mode, such remains of adhesive may be deposited on the drive roller as well.

- ▶ Clean the drive roller and the cutter blades often.

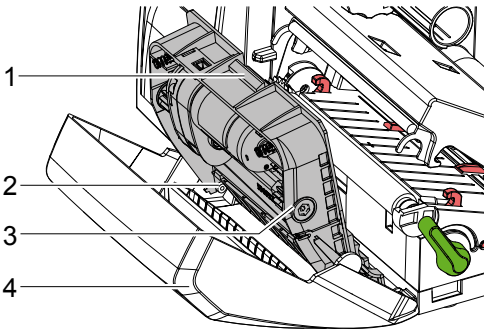

Fig. 18 Dismount Cutter

1. Fold down cutter.
2. Push release push button (1) and lift blade unit (3) from the cover (4).
3. If the blades are only slightly dirty it is sufficient to clean them with a soft cloth and continue with point 5.

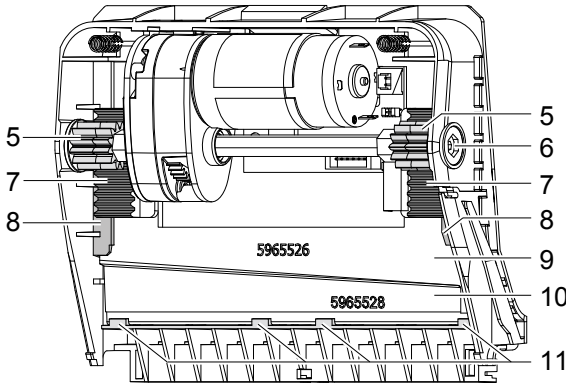

Fig. 19 Replace Blades

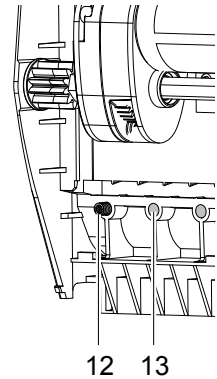

Fig. 20 Springs

4. If the blades are very dirty with residues of adhesive or if they are worn, change blades:
 - ▶ Turn shaft (6) clockwise using a torx wrench TX10 until the gear racks (7) cannot engage anymore.
 - ▶ Pull upper blade (9) out of the guides (8).
 - ▶ Take out lower blade (10).
 - ▶ Remove deposits on the blades with label remover and a soft cloth.
 - ▶ If necessary, replace blades.
 - ▶ Push lower blade down into the guides (11).
 - ▶ If necessary, put springs (12) back into spring retainers (13).
 - ▶ To re-mount the upper blade push lower blade down on the cover and push upper blade into the guide until the gear racks (7) can engage with the gear wheels (5).
 - ▶ Turn shaft (6) counterclockwise using a torx wrench TX10 until the blade reaches the upper limit.
5. Fit blade unit (3) according to Fig. 16 into the axes (2) and fold it towards the cover (4) until it snaps in.
6. Fold cutter/perforation cutter up to the print unit.

8.1 Problem Solution

Problem	Cause	Remedy
Print image has smears or voids	Printhead is dirty	Clean the printhead ▷ 7.2 on page 28
	Print roller is dirty	Clean the print roller ▷ 7.3 on page 30
	Print roller is worn/ damaged	Change the print roller ▷ 7.3 on page 30
Printer transports labels but does not print them.	Transfer ribbon inserted incorrectly	Check transfer ribbon feed path and orientation of the coated side and correct if necessary. Clean the printhead ▷ 7.2 on page 28

Table 3 Problem Solution

8.2 Error Messages and Fault Correction

Error message	Cause	Remedy
Out of ribbon	Out of transfer ribbon	Insert new transfer ribbon.
	Transfer ribbon melted during printing	Cancel current print job. Change the heat level via software. Clean the printhead ▷ 7.2 on page 28 Load transfer ribbon Restart print job.
	The printer is loaded with thermal labels, but the software is set to transfer printing	Cancel current print job. Set software to direct thermal printing. Restart print job.
Device not conn.	Programming addresses a non-existent optional device	Either connect this optional device or correct the programming.
No label found	There are labels missing on the label material	Press  repeatedly until printer recognizes the next label on the material.
	The label format as set in the software does not correspond with the real label format	Cancel current print job. Change the label format set in the software. Restart print job.
	Printer is loaded with continuous paper, but the software is set on labels	Cancel current print job. Change the label format set in the software. Restart the print job.
Head open	Printhead not locked	Lock printhead.
Head too hot	Printhead is overheated	After pausing the print job will be continued automatically. If the fault recurs repeatedly, reduce the heat level or the print speed via software.
Material too thick	Material too thick or hard, cutter does not cut through material but can return to initial position.	Cancel print job. Check material.



Error message	Cause	Remedy
Cutter blocked	Cutter cannot return into its home position and stays in an undefined position Material too thick or hard, cutter does not cut through material but can return to initial position.	Switch off the printer. Remove material. Switch on the printer. Restart print job. Check material
	No cutter function	Switch the printer off and then on. If error recurs call service.
Network Error	e.g. No DHCP server, no link, no SMTP server, no Timeserver	Please contact your network administrator.
Out of paper	Out of label roll	Load labels.
	Error in the paper feed, Material is not positioned under the label sensor.	Check paper feed.
Protocol error	Printer has received an unknown or invalid command from the computer, e.g. the command to perform a cut although a cutter is not mounted	Select  to skip the command or select  to cancel the print job.
Buffer overflow	The input buffer memory is full and the computer is still transmitting data.	Use data transmission via protocol (preferably RTS/CTS).
Memory overflow	Current print job contains too much information, e.g. selected font, large graphics	Cancel current print job. Reduce amount of data to be printed.
System Error	e.g. FPGA defective, invalid setup, voltage error	Switch the printer off and then on. Please note error details shown on the display. If error recurs call service.

Table 5 Error Messages and Fault Correction

9.1 EC Declaration of Conformity



5146477.CE.02

EG-Konformitätserklärung EC-Declaration of Conformity

Hersteller / Manufacturer: **PHOENIX CONTACT GMBH & CO. KG**
 Anschrift / Address: Flachsmarktstraße 8, D-32825 Blomberg, Germany

Produktbezeichnung / Product description: **THERMOMARK ROLL**
(Artikelbezeichnung, / Article description, Artikel-Nr. / Article no.) **5146477**

Das vorstehend bezeichnete Produkt stimmt mit den wesentlichen Anforderungen der nachfolgenden Richtlinie(n) und deren Änderungsrichtlinien überein / The above mentioned product is in line with the essential requirements of the below directive(s) and their modification directive(s):

2004/108/EC	EMV-Richtlinie (Elektromagnetische Verträglichkeit) Electromagnetic Compatibility Directive (EMC)
2006/95/EC	Niederspannungs-Richtlinie (NSR) Low Voltage Directive (LVD)

Für die Beurteilung der Übereinstimmung wurden folgende einschlägige Normen herangezogen:
 For evaluation of the conformity following relevant standards were consulted:

EN 60950-1:2006/A11:2009	EN 61558-1:2005/A1:2009	EN 55022:2006/A1:2007
EN 55024:1998/A1:2001/A2:2003	EN 61000-3-2:2006/A1:2009/A2:2009	EN 61000-3-3:2008
EN 61000-6-2:2005		

Weitere Informationen (z. B. Dokumente, Prüfberichte, Einschränkungen, etc.) zur Konformitätsbewertung:
 Additional information (for example documents, test reports, restrictions etc.,) of the conformity assessment:

Zertifikate einer benannten Stelle / Certificates by a notified body:

Anschrift / Address: _____
 Referenz / Reference: _____
 Anschrift / Address: _____
 Referenz / Reference: _____

Die letzten beiden Ziffern des Jahres in dem die CE-Kennzeichnung angebracht wurde:
 The last two figures of the year in which the CE marking was applied: 11
(nur einzutragen, bei der Niederspannungsrichtlinie / only to be entered on the low voltage directive)

Diese Erklärung gilt auch für die im Anhang aufgelisteten Produkte. (wenn angekreuzt)
 This declaration also applies for the products listed in the annex. (if marked with a cross)

Diese Erklärung bescheinigt die Übereinstimmung mit den wesentlichen Anforderungen der genannten Richtlinie(n), enthält jedoch keine Zusicherung von Eigenschaften. Die Sicherheits- und Einbauhinweise der mitgelieferten Produktdokumentation sind zu beachten.
 This declaration certifies the conformity with the essential requirements of the indicated directive(s), it does not, however, covenant any characteristics. The instructions for safety and installation of the enclosed product documentation have to be observed.

Blomberg, 2012-02-15

Sandra Klocke
 Sandra Klocke
 Business Unit Marking and Installation
 Head of Development
 Ansprechpartner / contact person

Dirk Gölitzner
 Dirk Gölitzner
 Division Industrial Components
 Senior Vice President, Head of the Division
 Zeichnungsberechtigter / authorized signatory



5146477.CE.02

**Anhang zur EG-Konformitätserklärung
Annex on EC Declaration of Conformity
vom / dated 2012-02-15**

Produktbezeichnung / *Product description*: THERMOMARK ROLL
(Artikelbezeichnung, / Article description,
 Artikel-Nr. / Article no.) 5146477

Die Konformität mit den wesentlichen Anforderungen der Richtlinie(n) wird auch für folgende Produkte bescheinigt:
The conformity with the essential requirements of the directive(s) is also certified by the declaration for following products.

<u>Artikel-Nr. / Article no.</u>	<u>Artikelbezeichnung / Article description</u>
<u>5146749</u>	<u>THERMOMARK ROLL AR</u>
<u>5146723</u>	<u>THERMOMARK ROLL X1</u>

9.2 FCC

NOTE : This equipment has been tested and found to comply with the limits for a Class A digital device, pursuant to Part 15 of the FCC Rules. These limits are designed to provide reasonable protection against harmful interference when the equipment is operated in a commercial environment. The equipment generates, uses, and can radiate radio frequency and, if not installed and used in accordance with the instruction manual, may cause harmful interference to radio communications. Operation of this equipment in a residential area is likely to cause harmful interference in which case the user may be required to correct the interference at his own expense.

9.3 GPL Code Statement

This product includes software code developed by third parties, including software code subject to the GNU General Public License ("GPL") or GNU Lesser General Public License ("LGPL"). As applicable, the terms of the GPL and LGPL, and information on obtaining access to the GPL Code and LGPL Code used in this product, are available to you at:

<http://www.phoenixcontact.net/catalog>
under the description of the printer.

The GPL Code and LGPL Code used in this product is distributed **WITHOUT ANY WARRANTY** and is subject to the copyrights of one or more authors. For details ,see the GPL Code and the LGPL Code for this product and the terms of the GPL and LGPL.

Written Offer to GPL Source Code:

Whereas such specific license terms entitle you to the source code of such software, PHOENIX CONTACT will provide upon written request via email and/or traditional paper mail the applicable GPL source code files via CD-ROM for a nominal cost to cover shipping and media charges as allowed under the GPL and LGPL.

Please direct all inquiries to:
PHOENIX CONTACT GmbH & Co. KG
Flachsmarktstraße 8
32825 Blomberg
DEUTSCHLAND

C

Cleaning
 Printhead.....29
 Print Roller30
 Connecting 15
 Contents of Delivery 14
 Critical error 19

D

Device Overview..... 11

E

Environment 10
 Error
 Correction.....34
 Messages.....34
 State..... 19

I

Important information..... 8
 Instructions 8
 Intended Use 9

L

Lithium Battery..... 10
 Loading Continuous Media
 from Roll21
 Loading Fanfold Labels22
 Loading Material.....21

M

Margin stops 11, 12
 Modifications..... 10

P

Pause 19
 Power Supply 15
 Printer States..... 19
 Printhead
 Cleaning29
 Damage.....27
 Problem Solution 33

R

Recycling..... 10

S

Safety Instructions 9
 Service Work 10
 Setting-up 14
 Supply Voltage..... 15
 Switching on the Device 17
 Symbols..... 18

T

Tear-off Mode 27
 Touchscreen Display 18

U

Unpacking..... 14

W

Warning Stickers 10



Компания «ЭлектроПласт» предлагает заключение долгосрочных отношений при поставках импортных электронных компонентов на взаимовыгодных условиях!

Наши преимущества:

- Оперативные поставки широкого спектра электронных компонентов отечественного и импортного производства напрямую от производителей и с крупнейших мировых складов;
- Поставка более 17-ти миллионов наименований электронных компонентов;
- Поставка сложных, дефицитных, либо снятых с производства позиций;
- Оперативные сроки поставки под заказ (от 5 рабочих дней);
- Экспресс доставка в любую точку России;
- Техническая поддержка проекта, помощь в подборе аналогов, поставка прототипов;
- Система менеджмента качества сертифицирована по Международному стандарту ISO 9001;
- Лицензия ФСБ на осуществление работ с использованием сведений, составляющих государственную тайну;
- Поставка специализированных компонентов (Xilinx, Altera, Analog Devices, Intersil, Interpoint, Microsemi, Aeroflex, Peregrine, Syfer, Eurofarad, Texas Instrument, Miteq, Cobham, E2V, MA-COM, Hittite, Mini-Circuits, General Dynamics и др.);

Помимо этого, одним из направлений компании «ЭлектроПласт» является направление «Источники питания». Мы предлагаем Вам помощь Конструкторского отдела:

- Подбор оптимального решения, техническое обоснование при выборе компонента;
- Подбор аналогов;
- Консультации по применению компонента;
- Поставка образцов и прототипов;
- Техническая поддержка проекта;
- Защита от снятия компонента с производства.



Как с нами связаться

Телефон: 8 (812) 309 58 32 (многоканальный)

Факс: 8 (812) 320-02-42

Электронная почта: org@eplast1.ru

Адрес: 198099, г. Санкт-Петербург, ул. Калинина, дом 2, корпус 4, литера А.