

## Silicon SPDT Surface Mount HMIC PIN Diode Switch RoHS Compliant

Rev. V9

### Features

- Operates 50 MHz to 20 GHz
- Usable up to 26 GHz
- Low Insertion Loss
- High Isolation
- Low Parasitic Capacitance and Inductance
- RoHS Compliant Surmount Package
- Rugged, Fully Monolithic
- Glass Encapsulated Construction
- Up to +38 dBm C.W. Power Handling @ +25°C
- Silicon Nitride Passivation
- Polymer Scratch Protection
- Solderable

### Description

The MASW-002103-1363 is a SPDT, surmount, broadband, monolithic switch using two sets of series and shunt connected PIN diodes. This device is designed for use in broadband, low to moderate signal, high performance, switch applications up to 20 GHz. It is a surface mountable switch configured for optimized performance and offers a distinct advantage over MMIC, beamlead and chip and wire hybrid designs. Because the PIN diodes of the MASW-002103-1363 are integrated into the chip and kept within close proximity, the parasitics typically associated with other designs that use individual components are kept to a minimum.

To minimize the parasitics and achieve high performance the MASW-002103-1363 is fabricated using M/A-COM Technology Solutions' patented HMIC™ (Heterolithic Microwave Integrated Circuit) process. This process allows the silicon pedestals, which form the series and shunt diodes or vias, to be imbedded in low loss, low dispersion glass. The combination of low loss glass and using tight spacing between elements results in an HMIC device with low loss and high isolation through low millimeter wave frequencies.

The topside is fully encapsulated with silicon nitride and also has an additional layer of polymer for scratch and impact protection. The protective coating guards against damage to the junction and the anode airbridges during handling and assembly.

On the backside of the chip gold metalized pads have been added to produce a solderable surmount device.

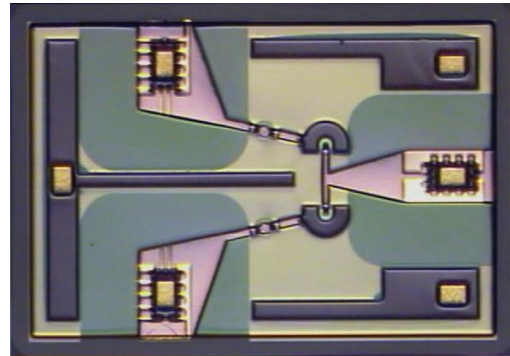

### Functional Schematic

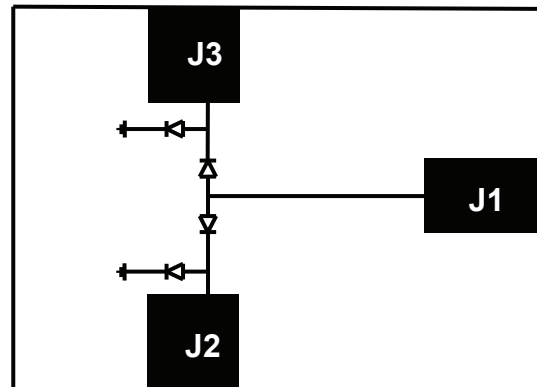

### Pin Configuration

Pin	Function
J1	RFC
J2	RF1
J3	RF2

### Ordering Information

Part Number	Package
MASW-002103-13630G	50 piece gel pack
MASW-002103-13635P	500 piece reel
MASW-002103-13630P	3000 piece reel
MASW-002103-001SMB	Sample Test Board

## Silicon SPDT Surface Mount HMIC PIN Diode Switch RoHS Compliant

Rev. V9

**Electrical Specifications:  $T_A = 25^\circ\text{C}$ ,  $P_{IN} = 0 \text{ dBm}$ ,  $Z_0 = 50 \Omega$ , 20mA/-10V**

Parameter	Frequency	Units	Min.	Typ.	Max.
Insertion Loss	6 GHz	dB	—	0.55	0.65
	13 GHz		—	0.80	0.95
	20 GHz		—	1.05	1.25
Input to Output Isolation	6 GHz	dB	38	52	—
	13 GHz		28	38	—
	20 GHz		23	27	—
Return Loss	6 GHz	dB	20	25	—
	13 GHz		17.3	23	—
	20 GHz		16.5	23	—
Input 0.1dB Compression Point	2 GHz	dBm	—	36	—
IIP3	0.05 GHz, 5 MHz Spacing, +10dBm	dBm	—	45	—
	0.5 GHz, 5 MHz Spacing, +20dBm		—	59	—
	1 GHz, 10 MHz Spacing, +20dBm		—	63	—
	2 GHz, 10 MHz Spacing, +20dBm		—	66	—
Switching Speed <sup>1</sup>	—	ns	—	20	—
Voltage Rating <sup>2</sup>	—	V	—	—	80

1. Typical Switching Speed measured from 10% to 90 % of detected RF signal driven by TTL compatible drivers.
2. Maximum reverse leakage current in either the shunt or series PIN diodes shall be 0.5  $\mu\text{A}$  maximum @ -80 volts.

### Absolute Maximum Ratings <sup>3,4</sup>

Parameter	Absolute Maximum
Operating Temperature	-65 °C to +125 °C
Storage Temperature	-65 °C to +150 °C
Junction Temperature	+175 °C
Applied Reverse Voltage	-80 V
RF CW Incident Power	38dBm CW @ 2GHz,+25°C 33dBm CW @ 20GHz,+25°C
Bias Current +25°C	$\pm 50 \text{ mA}$

3. Exceeding any one or combination of these limits may cause permanent damage to this device.
4. M/A-COM Tech does not recommend sustained operation at these survivability limits.

**Combined maximum operating conditions for RF power, DC bias, & temperature: 33dBm CW, 20mA per Diode, +85°C**

### Static Sensitivity

These devices are rated at Class 1A Human Body Model. Proper ESD control techniques should be used when handling these devices.

## Typical Small Signal Performance at +25°C (Probed On-Wafer RF Test)

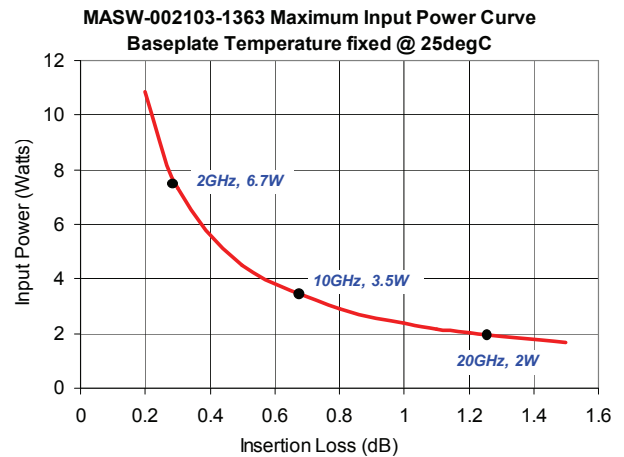
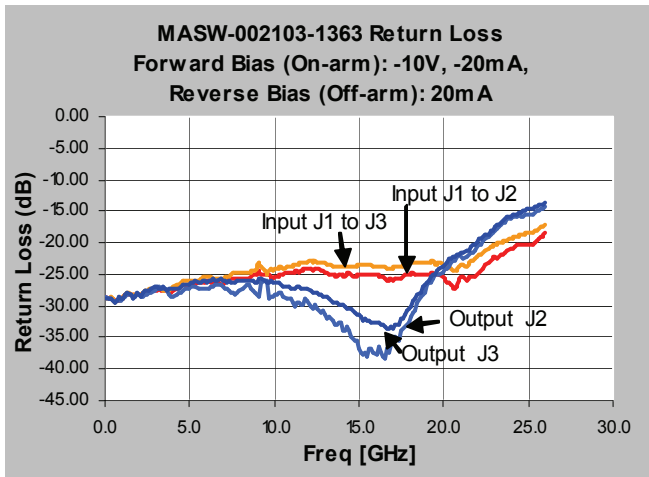
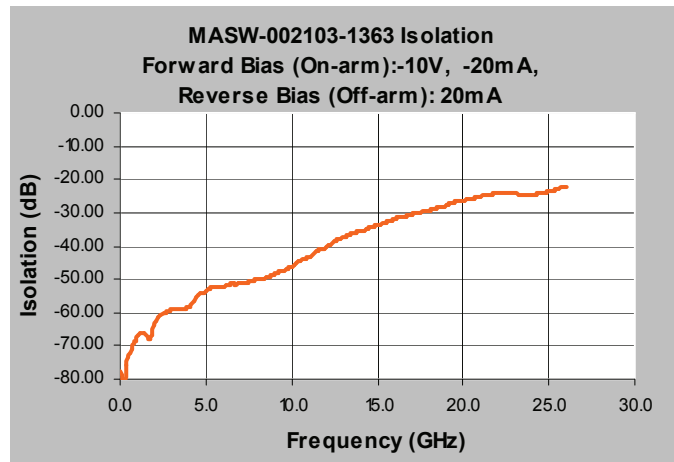
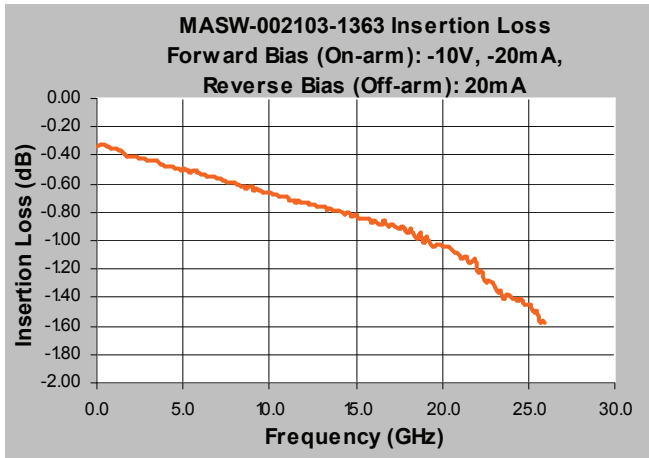

## Silicon SPDT Surface Mount HMIC PIN Diode Switch RoHS Compliant

Rev. V9

### Bias Control

Optimal operation of the MASW-002103-1363 is achieved by simultaneous application of negative DC voltage and current to the low loss switching arm and positive DC voltage and current to the remaining switching arm as shown in the circuit diagram below. DC return is achieved via R2 on the RFC path. In the low loss state, the series diode must be forward biased with current and the shunt diode reverse biased with voltage. In the isolated arm, the shunt diode is forward biased with current and the series diode is reverse biased with voltage.

### Driver Connections

Control Level (DC Currents and Voltages)		Condition of RF Output	Condition of RF Output
B2	B3	J1-J2	J1-J3
-15V at -20mA <sup>5</sup>	6V at +20mA	Low Loss	Isolation
6V at +20mA	-15V at -20mA <sup>5</sup>	Isolation	Low Loss

5. The voltage applied to the off arm is allowed to vary provided a constant current is applied through the shunt diode on the off arm.

### Application Circuit <sup>7,8,9,10,11</sup>

#### Example:

J1 to J2 → Low Loss  
 R1 = 250Ω  
 R2 = 450Ω  
 B2 = -15V  
 B3 = 6V

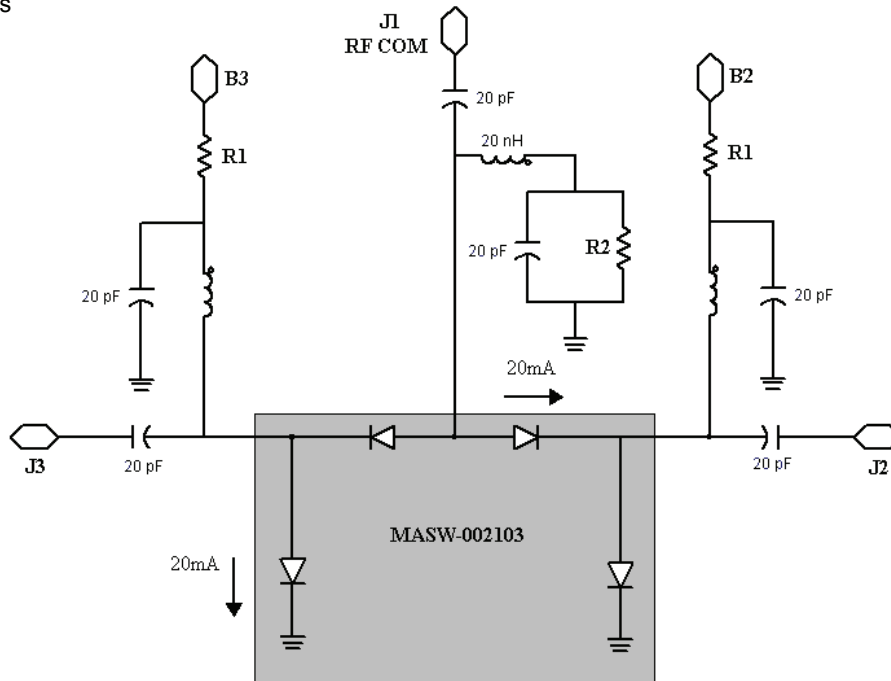

#### Notes:

- Assume  $V_f \sim 1V$  at 20mA
- $R1 = 5V / 0.02A = 250\Omega$ ;  $R2 = 9V / 0.02A = 450\Omega$
- $P_{R1} = 0.02A \times 0.02A \times 250 = 0.1 W$
- $P_{R2} = 0.02A \times 0.02A \times 450 = 0.18 W$
- Inductors shown in the above schematic are RF bias chokes. The operating bandwidth of a broad-band PIN diode switch is often dependent on the bias components, particularly the RF bias chokes. It is suggested that the response at the frequencies of interest be measured with all the bias components in place prior to installing of MASW-002103-1363.

## MASW-002103-1363 Outline Drawing (All dims. in $\mu\text{m}$ )

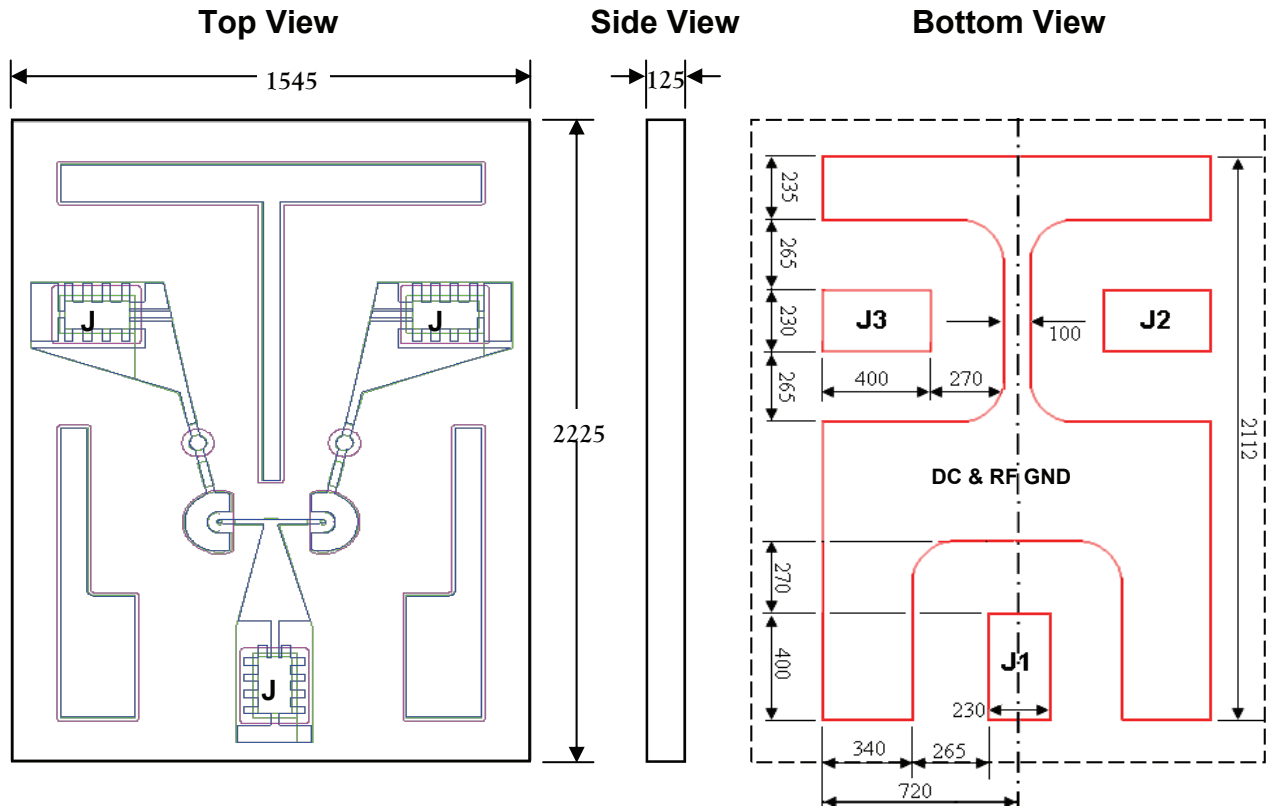

- 1) Bottom view shows the back metal foot print and mounting pads.
- 2) All dimension are  $\pm 0.5 \mu\text{m}$ .
- 3) The center pad shown on the chip bottom view must be connected to RF and DC ground

MASW- 002103-1363				
DIM	Inches		mm	
	MIN	MAX	MIN	MAX
Width	0.060	0.062	1.52	1.57
Length	0.087	0.089	2.20	2.25
Thickness	0.004	0.006	0.10	0.15

## Sample Board

Samples test boards are available upon request

## Handling Procedures

Attachment to a circuit board is made simple through the use of standard surface mount technology. Mounting pads are conveniently located on the bottom of the chip and are removed from the active junction locations making it well suited for solder attachment. Connections may be made onto hard or soft substrates via the use of 80Au/20Sn, or RoHS compliant solders. Typical re-flow profiles for provided in [Application Note M538](#), "Surface Mounting Instructions" and can viewed in the Customer Support, Technical Resources section of the MA-COM Technology Solutions website at [www.macomtech.com](http://www.macomtech.com).

For applications where the average power is  $\leq 1W$ , a thermally conductive silver epoxy may also be used. Cure per manufacturers recommended time and temperature. Typically 1 hour at 150°C.

When soldering these devices to a hard substrate, a solder re-flow method is preferred. A vacuum pick up tool with a soft tip is recommended while placing the chip . When soldering to soft substrates, such as Duroid, a soft solder is recommended at the circuit board to chip mounting pad interface to minimize stress due to any TCE mismatches that may exist. Position the die so that its mounting pads are aligned with the circuit board land pads. Solder reflow should not be performed by causing heat to flow through the top surface of the die to the back. Since the HMIC glass is transparent, the edges of the mounting pads can be visually inspected through the die after attachment is completed.

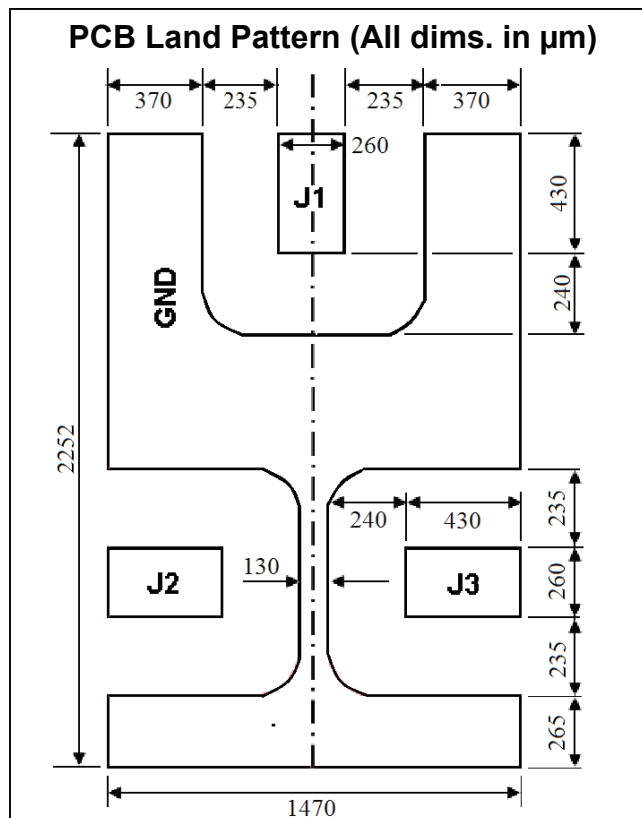

## Pocket Tape Dimensions

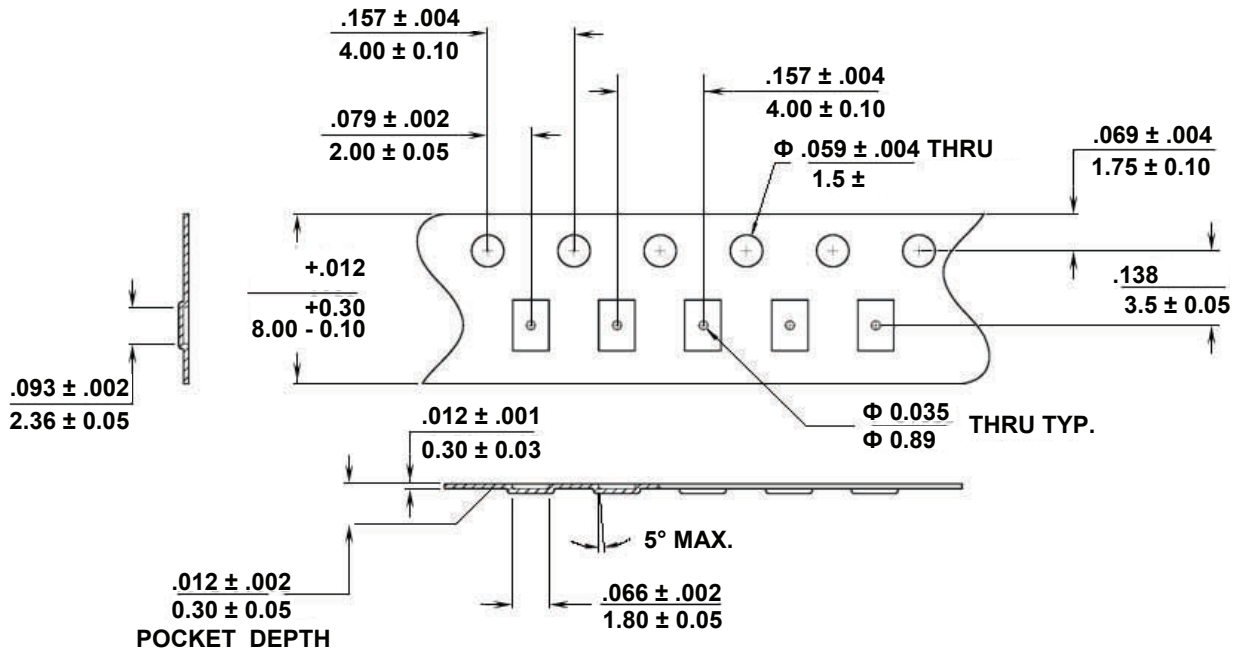

## Chip Orientation in Pocket

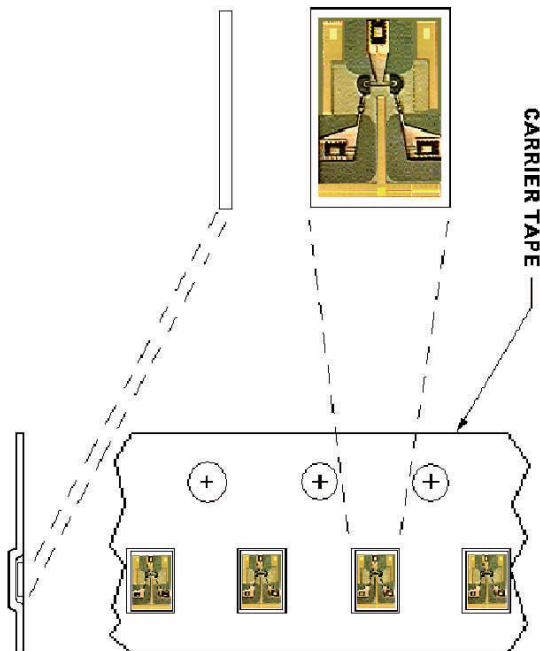

## Reel Information

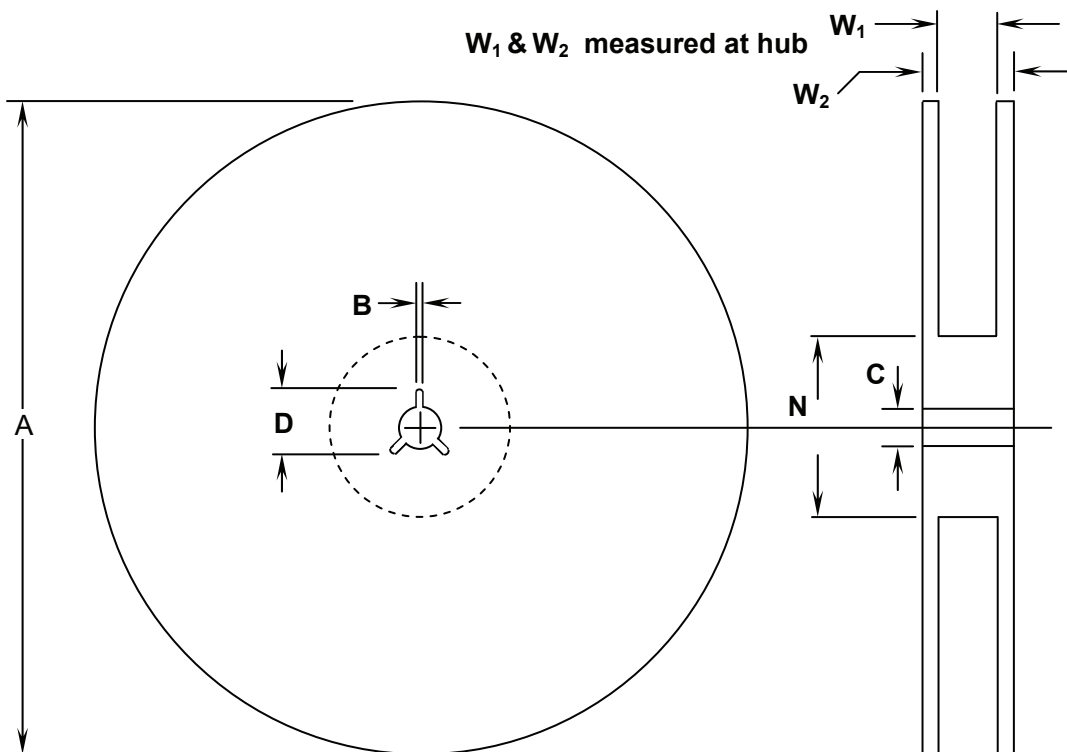

DIM	INCHES		MM	
	MIN.	MAX.	MIN.	MAX.
A	6.98	7.02	177.3	178.3
B	.059	.098	1.5	2.5
C	.504	.520	12.8	13.2
D	.795	.815	20.2	20.7
N	2.14	2.19	54.5	55.5
$W_1$	.331	.337	8.4	8.55
$W_2$	—	.567	—	14.4





Компания «ЭлектроПласт» предлагает заключение долгосрочных отношений при поставках импортных электронных компонентов на взаимовыгодных условиях!

Наши преимущества:

- Оперативные поставки широкого спектра электронных компонентов отечественного и импортного производства напрямую от производителей и с крупнейших мировых складов;
- Поставка более 17-ти миллионов наименований электронных компонентов;
- Поставка сложных, дефицитных, либо снятых с производства позиций;
- Оперативные сроки поставки под заказ (от 5 рабочих дней);
- Экспресс доставка в любую точку России;
- Техническая поддержка проекта, помощь в подборе аналогов, поставка прототипов;
- Система менеджмента качества сертифицирована по Международному стандарту ISO 9001;
- Лицензия ФСБ на осуществление работ с использованием сведений, составляющих государственную тайну;
- Поставка специализированных компонентов (Xilinx, Altera, Analog Devices, Intersil, Interpoint, Microsemi, Aeroflex, Peregrine, Syfer, Eurofarad, Texas Instrument, Miteq, Cobham, E2V, MA-COM, Hittite, Mini-Circuits, General Dynamics и др.);

Помимо этого, одним из направлений компании «ЭлектроПласт» является направление «Источники питания». Мы предлагаем Вам помощь Конструкторского отдела:

- Подбор оптимального решения, техническое обоснование при выборе компонента;
- Подбор аналогов;
- Консультации по применению компонента;
- Поставка образцов и прототипов;
- Техническая поддержка проекта;
- Защита от снятия компонента с производства.



#### Как с нами связаться

**Телефон:** 8 (812) 309 58 32 (многоканальный)

**Факс:** 8 (812) 320-02-42

**Электронная почта:** [org@eplast1.ru](mailto:org@eplast1.ru)

**Адрес:** 198099, г. Санкт-Петербург, ул. Калинина, дом 2, корпус 4, литера А.