

SMT Connectors

SMT Steckverbinder



Advantages and Special Features

This SMT connector was specifically developed for use with fully automatic assembly and solder procedures. The following special criteria were taken into account:

- Loading with „Pick and Place“ procedure via a vacuum grabber
- Application with “Tape on Reel” packaging
- Insulator in heat-resistant plastic
- RoHS compliant, 260°C/10s, for reflow soldering

Vorteile und Merkmale im Überblick

Diese SMT-Steckverbinder wurden gezielt für den Einsatz mit vollautomatischen Montage- und Lötverfahren entwickelt. Folgende spezielle Kriterien wurden dabei berücksichtigt:

- Bestückung im „Pick and Place“-Verfahren durch Vakuum-Greifer
- Einsatz mit „Tape on Reel“-Verpackungen
- Isolierkörper aus Hochtemperatur-Kunststoff
- RoHS konform, 260°C/10s, zum Reflow-Löten geeignet

Shell Dimensions

Gehäuseabmessungen

Pin Connector Shell

Stiftsteckverbindergehäuse

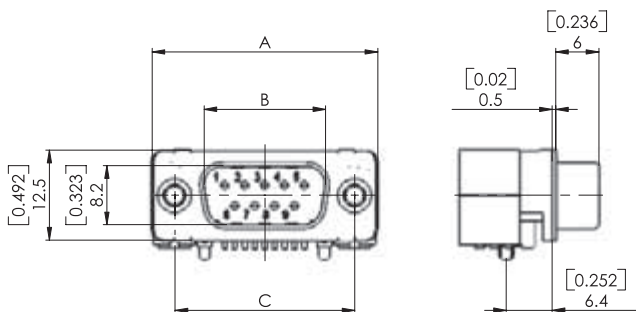

Shell Size	No. of Contacts	A	B	C
Gehäusegröße	Polzahl	±0,1 (±0.004)	±0,4 (±0.016)	+0,2 (+0.008) ±0,15 (±0.006)
1	9	31,4 (1.236)	16,9 (0.665)	25,0 (0.984)
2	15	39,2 (1.543)	25,2 (0.992)	33,3 (1.311)
3	25	53,2 (2.094)	38,9 (1.531)	47,04 (1.852)

Dimensions in mm (inch) - Abmessungen in mm (inch)

Socket Connector Shell

Buchsensteckverbindergehäuse

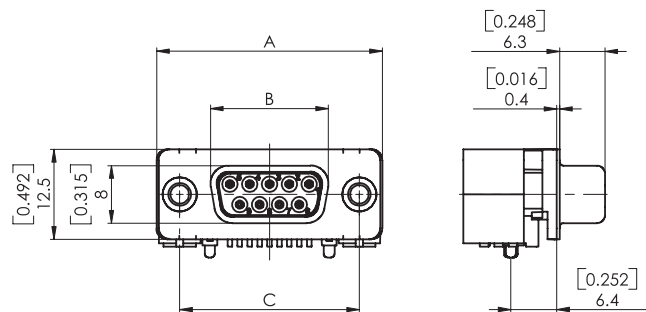

Shell Size	No. of Contacts	A	B	C
Gehäusegröße	Polzahl	±0,1 (±0.004)	±0,4 (±0.016)	- 0,2 (- 0.008) ±0,15 (±0.006)
1	9	31,4 (1.236)	16,4 (0.646)	25,0 (0.984)
2	15	39,2 (1.543)	24,7 (0.972)	33,3 (1.311)
3	25	53,2 (2.094)	38,5 (1.516)	47,04 (1.852)

Dimensions in mm (inch) - Abmessungen in mm (inch)



Order Code

Bestellschlüssel

	F	SL	T	09	P	101	G1	...
Series Prefix / Serienbezeichnung								
Insulator / Isolierkörper								
SL	Surface Mounted (Can be soldered on PCB surface) Surface Mounted (Auf Leiterplattenoberfläche auflötbar)							
Mounting Type / Befestigungsarten								
T	4-40 UNC 4-40 UNC							
Z	M3 M3							
U	Spacer 4-40 UNC Abstandsbolzen 4-40 UNC							
M	Spacer M3 Abstandsbolzen M3							
D	Through Hole Durchgangsloch							
No. of Contacts / Polzahl	09	15	25					
Shell Size / Gehäusegröße	1	2	3					
Contact Type / Kontaktart								
P	Pin contact Stiftkontakt							
S	Socket contact Buchsenkontakt							
Contact Design, e.g. / Kontaktvarianten, z.B.								
101	Overall Hight 3,7 mm (0.146") Bauhöhe 3,7mm							
107	Overall Hight 7,3 mm (0.287") Bauhöhe 7,3 mm							
More contacts and layouts on request. <i>Weitere Kontakte und Layouts auf Anfrage.</i>								
Direction of Right Angled Contacts Richtung der abgewinkelten Kontakte								
--	Standard / Standard							
R	Revers* Revers*							
Performance Classes Available in Accordance with Din 41652 Lieferbare Gütestufe nach DIN 41652								
G1	= 500 Contact Cycles = 500 Steckzyklen	= Performance Class 1 = Gütestufe 1						
G2	= 200 Contact Cycles = 200 Steckzyklen	= Performance Class 2* = Gütestufe 2*						
G3	= 50 Contact Cycles = 50 Steckzyklen	= Performance Class 3* = Gütestufe 3*						
Modifications / Modifikationen								
*On request / *auf Anfrage								

Materials and Platings

Materialien und Oberflächen

Shell <i>Gehäuse</i>	Steel <i>Stahl</i>
Insulator <i>Isolierkörper</i>	Heat resistant, glass filled (UL94V-0) <i>hochtemperaturbeständig, glasfaserverstärkt (UL94V-0)</i>
Relative temperature index according to UL 746 B <i>rel. Temperaturindex nach UL 746 B</i>	≥150 °C (≥302 °F)
Heat deflection temperature limit according to DIN 53461 HDT/A <i>Formbeständigkeitstemperatur nach DIN 53461 HDT/A</i>	≥276 °C (≥529 °F)
Sub temperature limit <i>Untere Grenztemperatur</i>	-55 °C (-67 °F)
Shell plating (standard) <i>Gehäuseoberfläche (Standard)</i>	Tin plated over nickel* <i>verzinkt über Nickel*</i>
Shell (standard) <i>Gehäuse (Standard)</i>	Pin connector shell with dimples <i>Stiftsteckverbindergehäuse mit Kontaktnoppen</i>
Contact material <i>Kontaktmaterial</i>	Copper alloy <i>Kupfer-Legierung</i>

*On request nickel plated over copper / *Auf Anfrage vernickelt über Kupfer

Electrical Data

Elektrische Daten

Current rating at room temperature <i>Maximale Stromstärke bei Raumtemperatur</i>	5 A
Test voltage between 2 contacts / shell and contact <i>Prüfspannung zwischen 2 Kontakten bzw. Kontakt u. Gehäuse</i>	1200 V / 1 min.
Insulation resistance between contacts <i>Isolationswiderstand Kontakt / Kontakt</i>	≥ 5000 MΩ
Volume resistivity <i>Spezifischer Durchgangswiderstand</i>	≤ 10 ¹⁶ Ω cm



Right Angled Signal Contacts (SMT)

Abgewinkelte Signalkontakte (SMT)

Overall Height 3.7 mm (0.146")

Bauhöhe 3,7 mm

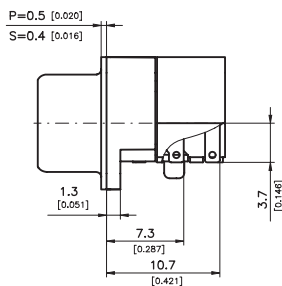

Contact design
Kontaktvariante **101**

Overall Height 7.3 mm (0.287")

Bauhöhe 7,3 mm

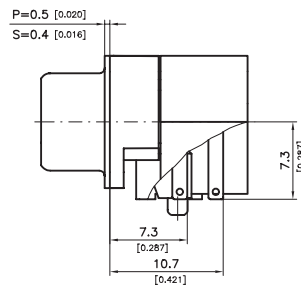

Contact design
Kontaktvariante **107**

PCB Layout

Leiterplattenlayout

9 Contacts

9-polig

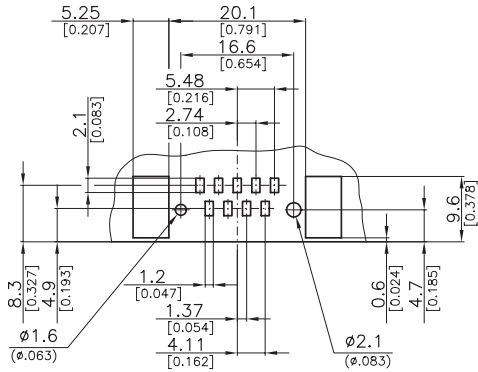

15 Contacts

15-polig

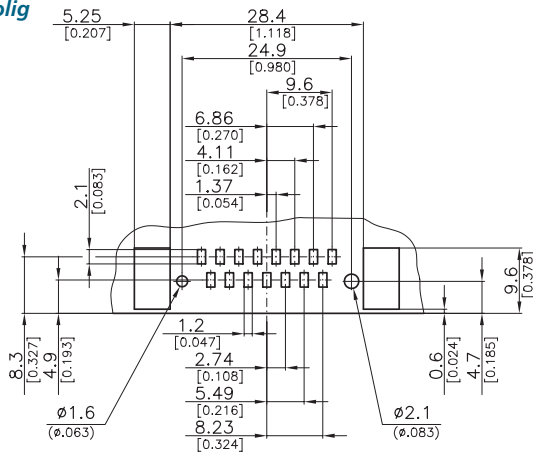

25 Contacts

25-polig

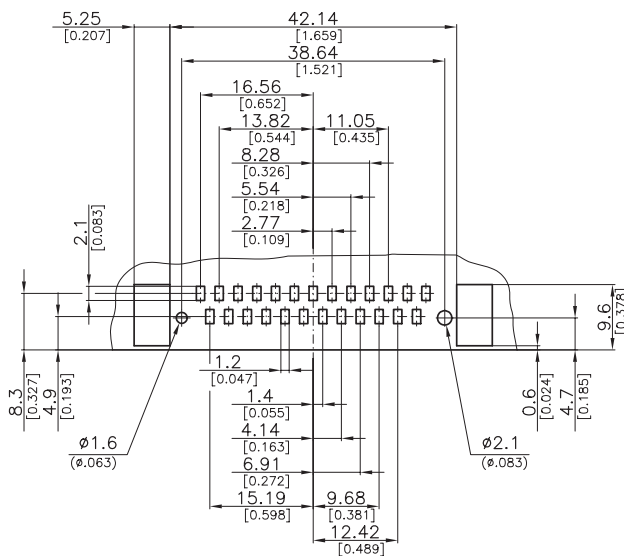

Summary of Connector Designs

Übersicht Steckverbindervarianten

Other dimensions possible on request
Andere Abmaße auf Anfrage möglich

Please see order code on page 30.
Siehe auch Bestellschlüssel auf Seite 30.

FSL... Connector Designs FSL...Steckverbinder-varianten		Contact Design Kontaktvariante		
No. of Contacts Polzahl				
09/15/25	4-40 UNC	...T		
	M3	...Z		
	M3	...M		
	4-40 UNC	...U		
		101		107



Packing Units

SMT connectors are located in the blister tape in the unreeling direction of the tape.

The connectors are not usually stamped, as they are normally delivered in blister tape on a reel (Tape on reel) and the labels can be found on the reel.

Verpackungseinheiten

Lageorientierung der SMT-Steckverbinder im Blistergurt in Abrollrichtung des Blistergurtes.

Die Steckverbinder werden standardmäßig nicht bedruckt, da die Steckverbinder üblicherweise in einem Blistergurt auf Rollen (Tape on Reel) geliefert werden und sich das Etikett auf der Spule befindet.

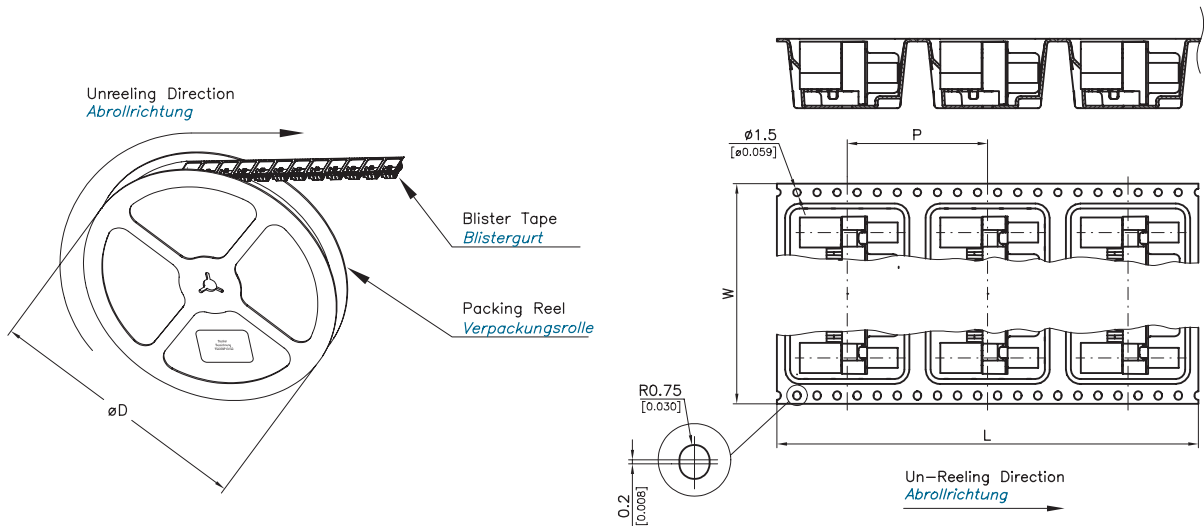

Connector Steckverbinder	Connectors per Reel Steckverbinder pro Rolle	D	W	P	L
FSL...09P/S101	182	330,2 (13)	44,0 (1.732)	28,0 (1.102)	5124 (201.732)
FSL...15P/S101	182	330,2 (13)	56,0 (2.205)	28,0 (1.102)	6804 (267.874)
FSL...25P/S101	182	330,2 (13)	72,0 (2.835)	28,0 (1.102)	6804 (267.874)
FSL...09P/S107	140	330,2 (13)	44,0 (1.732)	28,0 (1.102)	3948 (155.433)
FSL...15P/S107	140	330,2 (13)	56,0 (2.205)	28,0 (1.102)	5460 (214.961)
FSL...25P/S107	140	330,2 (13)	72,0 (2.835)	28,0 (1.102)	5460 (214.961)

Dimensions in mm (inch) - *Abmessungen in mm (inch)*

Further packing units on request.
Depending upon the automating medium used, please request the minimum order quantities (see page 445).

Weitere Verpackungseinheiten auf Anfrage.
Bitte erfragen Sie abhängig von dem verwendeten Automatisierungshilfsmittel (siehe Seite 445) die Mindestbestellmenge.



Компания «ЭлектроПласт» предлагает заключение долгосрочных отношений при поставках импортных электронных компонентов на взаимовыгодных условиях!

Наши преимущества:

- Оперативные поставки широкого спектра электронных компонентов отечественного и импортного производства напрямую от производителей и с крупнейших мировых складов;
- Поставка более 17-ти миллионов наименований электронных компонентов;
- Поставка сложных, дефицитных, либо снятых с производства позиций;
- Оперативные сроки поставки под заказ (от 5 рабочих дней);
- Экспресс доставка в любую точку России;
- Техническая поддержка проекта, помощь в подборе аналогов, поставка прототипов;
- Система менеджмента качества сертифицирована по Международному стандарту ISO 9001;
- Лицензия ФСБ на осуществление работ с использованием сведений, составляющих государственную тайну;
- Поставка специализированных компонентов (Xilinx, Altera, Analog Devices, Intersil, Interpoint, Microsemi, Aeroflex, Peregrine, Syfer, Eurofarad, Texas Instrument, Miteq, Cobham, E2V, MA-COM, Hittite, Mini-Circuits, General Dynamics и др.);

Помимо этого, одним из направлений компании «ЭлектроПласт» является направление «Источники питания». Мы предлагаем Вам помощь Конструкторского отдела:

- Подбор оптимального решения, техническое обоснование при выборе компонента;
- Подбор аналогов;
- Консультации по применению компонента;
- Поставка образцов и прототипов;
- Техническая поддержка проекта;
- Защита от снятия компонента с производства.



Как с нами связаться

Телефон: 8 (812) 309 58 32 (многоканальный)

Факс: 8 (812) 320-02-42

Электронная почта: org@eplast1.ru

Адрес: 198099, г. Санкт-Петербург, ул. Калинина, дом 2, корпус 4, литера А.