

Door Interlock Switch D2D

Power Switch with Minimum Contact Gap up to 3 mm.

- Minimum contact gap of 3 mm (standard models), needed in general power switches, is provided.
- Mechanism with double return spring and direct drive positive contact opening features
- Pull-on lock type for easy maintenance is also available.
- Conforms to Class II of VDE Insulation Grade.
- RoHS Compliant



Ordering Information

Type	Contact Gap	Contact Form	Part Number	
			Screw mount type	Panel mount type
Standard	3 mm min.	SPDB-NO/NC	D2D-1000	D2D-1100
		SPDB-NO	D2D-1001	D2D-1101
		SPDB-NC	D2D-1002	D2D-1102
		SPDB-NO + SPDB-NO/NC	- - -	D2D-3103
		DPDB-NO	- - -	D2D-3104
Pull-on lock	1 mm	SPDB-NO/NC	D2D-2000	D2D-2100

Note: "DB" in the contact form = "Double Break".

Model Number Legend

D2D -
 1 2 3

1. Construction

- 1: Single pole, 3-mm contact gap
- 2: Pull-on-lock type, 1-mm contact gap
- 3: Double-pole, 3-mm contact gap

2. Mounting

- 0: Screw mount
- 1: Panel snap-fit mount

3. Contact Form

- 0: SPDB-NO/NC
- 1: SPDB-NO
- 2: SPDB-NC
- 3: SPDB-NO + SPDB-NO/NC
- 4: DPDB-NO

Specifications

■ Characteristics

Item		D2D-1000 models	D2D-2000 models	D2D-3000 models
Operating speed		10 mm/s to 1 m/s		
Operating frequency		Mechanical: 300 operations per minute max. Electrical: 30 operations per minute max.		
Contact resistance		50 mΩ max.		
Insulation resistance		100 MΩ min. (at 500 VDC)		
Dielectric strength 50/60 Hz, 1mm (See note 2)	Between terminals of same polarity	2,000 VAC	1,000 VAC	2,000 VAC
	Between terminals and ground	2,000 VAC	1,500 VAC	2,000 VAC
	Between terminals and non-current carrying metal parts	2,500 VAC	1,500 VAC	---
	Between terminals and actuator	4,000 VAC	---	4,000 VAC
Vibration resistance		Malfunction: 10 to 55 Hz, 1.5 mm double amplitude		
Shock resistance	Destruction	1,000 m/s ² (approx 100G) max.		
	Malfunction	500 m/s ² (approx. 50G) max.	300 m/s ² (approx. 30G) max.	500 m/s ² (approx. 50G) max.
Degree of protection		IEC IP40		
Degree of protection vs. electric shock		Class II		
Proof tracking index (PTI)		175		
Ambient operating temperature		-25° to 85°C (at 60% RH max.) with no icing		
Ambient operating humidity		85% max (for 5°C to 35°C)		
Life expectancy		Mechanical: 10,000,000 operations min. at 60 operations/minute Electrical: 100,000 operations min. at 30 operations/minute		
Weight		Approx. 14 g (D2D-1000)		

- Note:** 1. Data shown are of initial value
2. The dielectric strength shown is measured using a separator between the switch and metal mounting plate

■ Ratings (Reference values)

Type	Voltage	Resistive load		Motor load	
		NC	NO	NC	NO
Standard	125 VAC 250 VAC	16 A		4 A	
Pull-on lock	125 VAC 250 VAC	10 A		---	

- Note:** 1. The above values are for steady-state current and the motor load has an inrush current of 6 times the steady-state current.
2. The ratings apply under the following test conditions: Ambient Temperature = 20±2°C, Ambient Humidity = 65±5%, Operating frequency = 30 operations/min.

■ Approved Standards

UL Recognized (File No. E41515)
CSA Certified (File No. LR21642)

Rated voltage	D2D-1000	D2D-2000	D2D-3000
125 VAC	---	---	3/4 hp
250 VAC	16 A	10 A	16A, 1.5 hp

EN61058-1 (File No. 136005 VDE approval)

Rated voltage	D2D-1000	D2D-2000	D2D-3000
250 VAC	16(4) A	10 A	16(4) A

Testing conditions: 1E4 (10,000 operations), T85 (0°C to 85°C)

Note: The value in parentheses indicate motor load ratings.

EN61058-1 (File No. R9551934, TÜV Rheinland approval)

Rated voltage	D2D-3104
24 VDC	4 A

Testing conditions: 5E4 (50,000 operations), T85 (0°C to 85°C)

■ Contact Specifications

Item	Standard model	Pull-on lock model
Specification	Rivet	
Material	Silver	
Gap (standard value)	3 mm min.	1 mm
Inrush current	30 A max.	24 A max.
Minimum applicable load (see note)	160 mA at 5 VDC	

Note: Minimum applicable loads are indicated by N standard reference values. This value represents the failure rate at a 60% (λ_{60}) reliability level (JIS C5003).
The equation $\lambda_{60}=0.5 \times 10^{-6} / \text{operations}$ indicates that a failure rate of 1/2,000,000 operations can be expected at a reliability level of 60%

Engineering Data

Mechanical Service Life

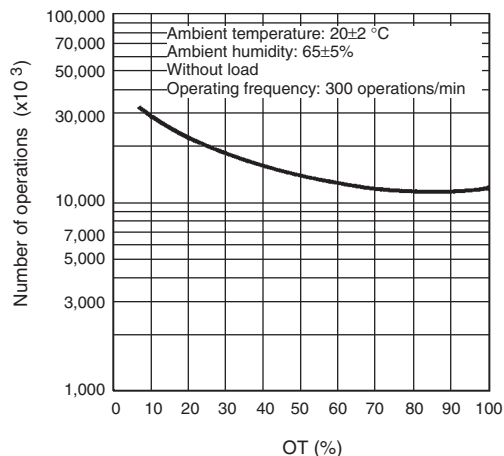

Electrical Service Life

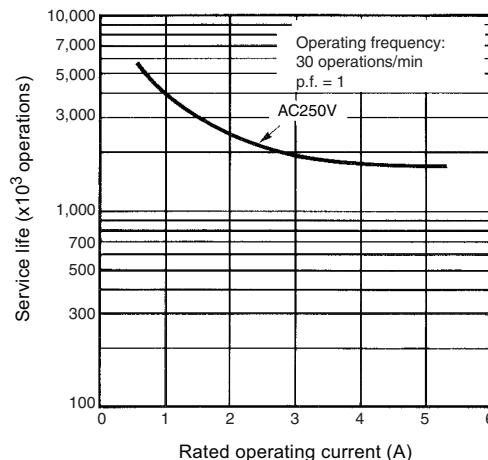

Contact Form

SPDB-NO/NC

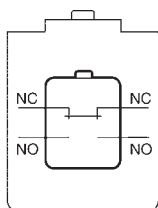

D2D-1000 D2D-2000
D2D-1100 D2D-2100

SPDB-NO

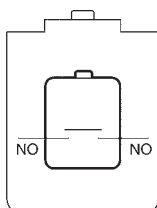

D2D-1001
D2D-1101

SPDB-NC

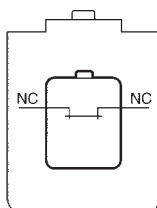

D2D-1002
D2D-1102

SPDB-NO +
SPDB-NO/NC

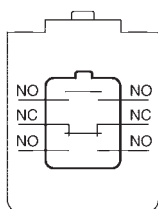

D2D-3103

DPDB-NO

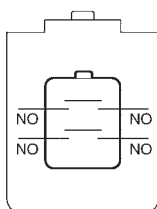

D2D-3104

Mounting Holes

Screw mount switches may be panel mounted using M4 mounting screws with plane washers or spring washers to securely mount the switch. Tighten the screws to a torque of 0.49 to 0.69 N·m

Panel Mount Holes

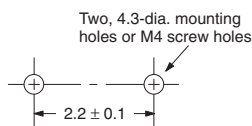

Panel Cutout Dimensions

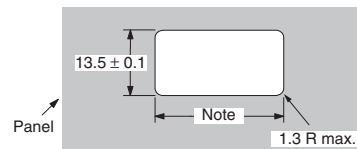

Panel thickness: 1.0 to 2.5 mm

Note: Dimension is 36.7±0.1 with a panel thickness of 1.0 mm and 37.0±0.1 with a panel thickness of 2.5 mm



Screw mount type panel

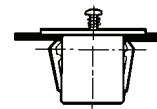

Panel mount type panel

Snap-fit panel mount switches use the panel cutout hole illustrated above. When mounting on a metal surface, be sure to provide a separator between the switch and mounting plate.

Pull-on Lock Function

When opening or closing the door, the power ON state of the switch can be checked with the door left open. By closing the door after maintenance inspection, the switch will resume the normal momentary action. (this feature is ideal for conducting the electrical continuity test, inspection, repair, etc. of the switch after its assembly.)

Example		To turn ON the power when the door is closed	To turn OFF the power when the door is open	To turn ON the power with the door left open
Connection	NO-NO	ON	OFF	ON
	NC-NC	OFF	ON	OFF

■ Safety Features

Double Spring Mechanism

Two return springs are provided for the pin plunger. Thus, if either of the springs are broken, this feature will prevent the switch from malfunctioning or short-circuiting.

(Applicable to D2D-1000 and D2D-3000 models. The D2D-2000 models with pull-on lock is not provided with this feature.)

Direct Contact Opening Mechanism

The insulating ring, identified by , will positively break the circuit if a contact weld occurs in the switch. (D2D-1000 models).

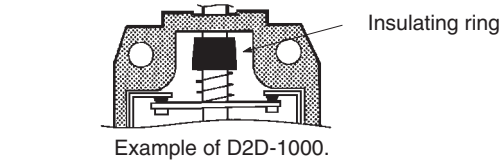

The section marked  pushes the movable contact to apply force in the direction which separates the movable contact forcibly from the fixed contact.

■ Structure

Standard Types

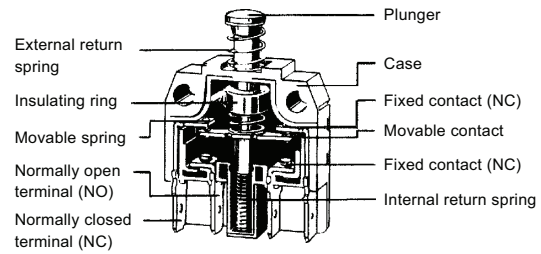

Pull-on Lock Types

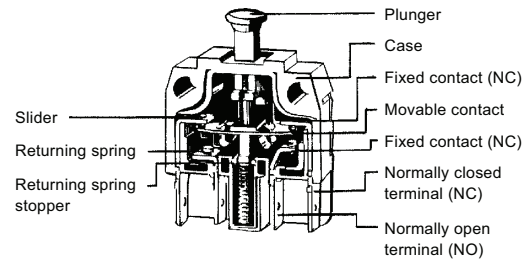

Dimensions and Operating Characteristics

- Note:** 1. Unless otherwise specified, all units are in millimeters and a tolerance of ± 0.4 mm applies to all dimensions
 2. The operating characteristics are for operation in the A direction()

■ Standard Models

Screw Mounting

D2D-1000
 D2D-1001
 D2D-1002

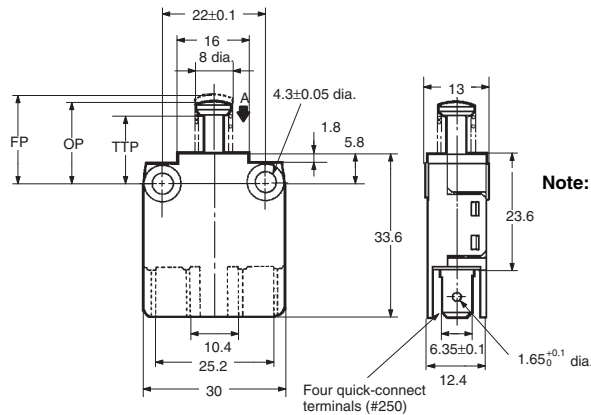

- Note:** 1. NC-OFF: The force applied to the actuator to cause it to move from the free position to the position at which the NC contact opens.
 2. NO-ON: The force applied to the actuator to cause it to move from the free position to the position at which the NO contact closes

Model		D2D-1000	D2D-1001	D2D-1002
OF max.	NC-OFF	300 gf	---	300 gf
	NO-ON	600 gf	600 gf	---
TTF max.			750 gf	
OT min.		2.3 mm		5.5 mm
FP max.		16.4 mm	17 mm	16.4 mm
OP	NC-OFF	15.9 ± 0.4 mm	---	15.9 ± 0.4 mm
	NO-ON	12.7 ± 0.4 mm	12.7 ± 0.4 mm	---
TTP max.			10 mm	

- Note:** 1. Unless otherwise specified, all units are in millimeters and a tolerance of ± 0.4 mm applies to all dimensions
 2. The operating characteristics are for operation in the A direction(▼)

Panel Mounting

D2D-1100
 D2D-1101
 D2D-1102

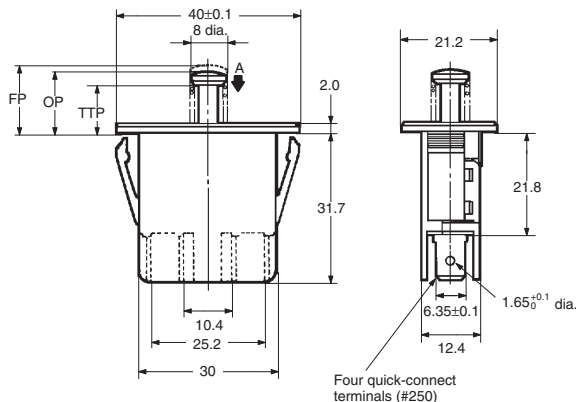
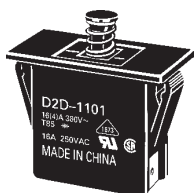

	Model	D2D-1100	D2D-1101	D2D-1102
OF max.	NC-OFF NO-ON	300 gf 600 gf	---	300 gf ---
TTF max.		750 gf		
OT min.		2.3 mm		5.5 mm
FP max.		12.4 mm	13 mm	12.4 mm
OP	NC-OFF NO-ON	11.9 ± 0.4 mm 8.7 ± 0.4 mm	---	11.9 ± 0.4 mm ---
TTP max.		6 mm		

Panel Mounting

D2D-3103

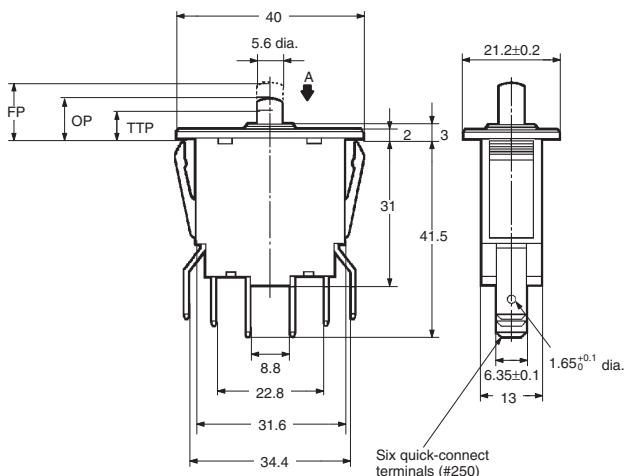
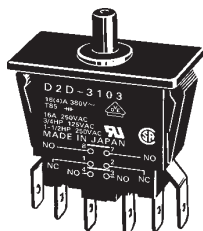

	Model	D2D-3103
OF max.	NC-OFF NO-ON	300 gf 600 gf
TTF max.		1,000 gf
OT min.		2.3 mm
FP max.		12.4 mm
OP	NC-OFF NO-ON	11.9 ± 0.8 mm 8.7 ± 0.8 mm
TTP max.		6.4 mm

Panel Mounting

D2D-3104

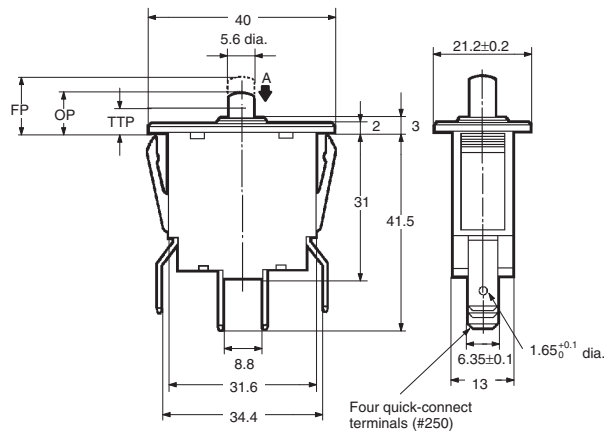
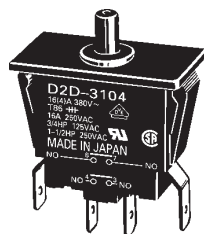

	Model	D2D-3104
OF max.	NC-OFF NO-ON	---
TTF max.		1,000 gf
OT min.		2.3 mm
FP max.		13.4 mm
OP	NC-OFF NO-ON	---
TTP max.		8.7 ± 0.8 mm 6.4 mm

- Note:** 1. Unless otherwise specified, all units are in millimeters and a tolerance of ± 0.4 mm applies to all dimensions
 2. The operating characteristics are for operation in the A direction(▼)

■ Pull-on Lock Models

Screw Mounting

D2D-2000



Note: At pull-on lock operation.

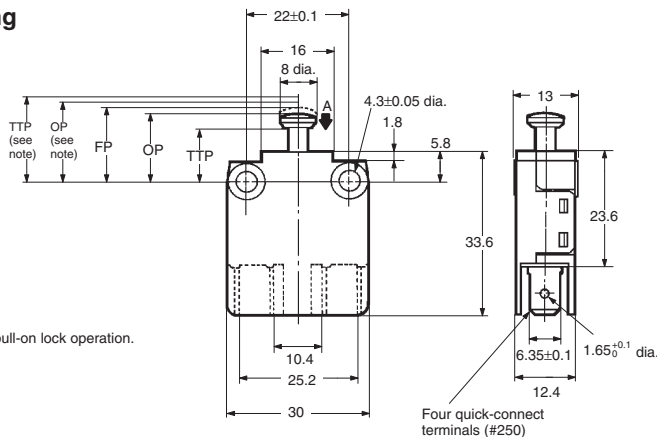

Momentary Operation (Normal Operation)

Model	D2D-2000	D2D-2100
OF max.	NC-OFF NO-ON	200 gf 300 gf
TTF max.	600 gf	
OT min.	4.5 mm	
FP max.	14.3 mm	10.3 mm
OP	NC-OFF NO-ON	13.5 ± 0.6 mm 9.5 ± 0.6 mm
TTP max.	8.3 mm	4.3 mm

Panel Mounting

D2D-2100

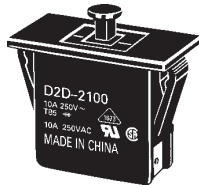

Note: At pull-on lock operation.

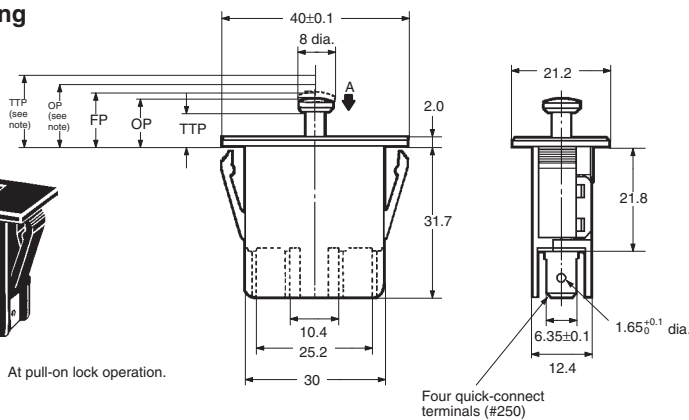

Pull-on Lock Operation

Model	D2D-2000	D2D-2100
OF max.	2,000 gf	
PT max.	2 mm	
OT min.	0.4 mm	
MD max.	1.5 mm	
FP max.	14.3 mm	10.3 mm
OP	15.1 ± 0.6 mm	11.1 ± 0.6 mm
TTP max.	16.5 mm	12.5 mm

Precautions

Be sure to read the precautions and information common to all Snap Action and Detection Switches, contained in the Technical User's Guide, "Snap Action Switches, Technical Information" for correct use.

■ Correct Use

Actuation

Apply operation force to the pin plunger in the direction it operates. Applying forces laterally or from an oblique direction may damage the pin plunger.

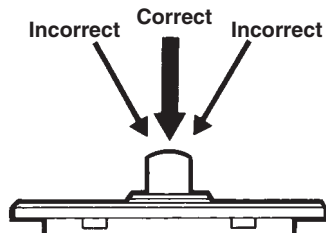

Using Microloads

Using a model for ordinary loads to switch microloads may result in faulty operation. Instead, use the models that are designed for microloads and that operate in the following range;

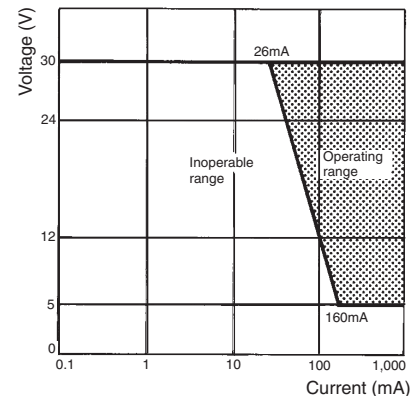

However, even when using microload models within the operating range shown above, if inrush current or inductive voltage spikes occur when the contact is opened or closed, then contact wear may increase and so decrease the service life. Therefore, insert a contact protection circuit where necessary.

A large grid of 20 columns and 30 rows of small squares, used for taking notes or drawing diagrams. The grid is composed of thin, light gray lines forming a uniform pattern across the page.

All sales are subject to Omron Electronic Components LLC standard terms and conditions of sale, which can be found at http://www.components.omron.com/components/web/webfiles.nsf/sales_terms.html

ALL DIMENSIONS SHOWN ARE IN MILLIMETERS.
To convert millimeters into inches, multiply by 0.03937. To convert grams into ounces, multiply by 0.03527.

OMRON[®]

**OMRON ELECTRONIC
COMPONENTS LLC**

55 E. Commerce Drive, Suite B
Schaumburg, IL 60173

847-882-2288

OMRON ON-LINE

Global - <http://www.omron.com>

USA - <http://www.components.omron.com>

Cat. No. X303-E-1

11/10

Specifications subject to change without notice

Printed in USA



Компания «ЭлектроПласт» предлагает заключение долгосрочных отношений при поставках импортных электронных компонентов на взаимовыгодных условиях!

Наши преимущества:

- Оперативные поставки широкого спектра электронных компонентов отечественного и импортного производства напрямую от производителей и с крупнейших мировых складов;
- Поставка более 17-ти миллионов наименований электронных компонентов;
- Поставка сложных, дефицитных, либо снятых с производства позиций;
- Оперативные сроки поставки под заказ (от 5 рабочих дней);
- Экспресс доставка в любую точку России;
- Техническая поддержка проекта, помощь в подборе аналогов, поставка прототипов;
- Система менеджмента качества сертифицирована по Международному стандарту ISO 9001;
- Лицензия ФСБ на осуществление работ с использованием сведений, составляющих государственную тайну;
- Поставка специализированных компонентов (Xilinx, Altera, Analog Devices, Intersil, Interpoint, Microsemi, Aeroflex, Peregrine, Syfer, Eurofarad, Texas Instrument, Miteq, Cobham, E2V, MA-COM, Hittite, Mini-Circuits, General Dynamics и др.);

Помимо этого, одним из направлений компании «ЭлектроПласт» является направление «Источники питания». Мы предлагаем Вам помощь Конструкторского отдела:

- Подбор оптимального решения, техническое обоснование при выборе компонента;
- Подбор аналогов;
- Консультации по применению компонента;
- Поставка образцов и прототипов;
- Техническая поддержка проекта;
- Защита от снятия компонента с производства.



Как с нами связаться

Телефон: 8 (812) 309 58 32 (многоканальный)

Факс: 8 (812) 320-02-42

Электронная почта: org@eplast1.ru

Адрес: 198099, г. Санкт-Петербург, ул. Калинина, дом 2, корпус 4, литера А.