

PULSEJACK™

1x1 Tab-UP RJ45

Description:

10/100 Base-TX RJ45 1x1 Tab-UP with LEDs 8-pin (J1 series) and 6-pin (JP series) integrated magnetics connector, designed to support applications, such as ADSL modems, LAN-on-Motherboard, and Hub and Switches.

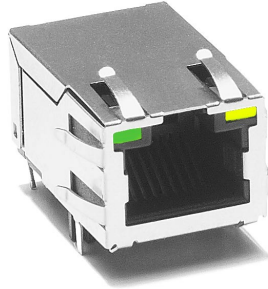

Features and Benefits:

- RoHS peak wave solder temperature rating 260°C
- Suitable for CAT 5 & 6 Fast Ethernet Cable or better UTP

Electrical Performance Summary:

- Meets IEEE 802.3 specification
- 350µH minimum OCL with 8mA bias current
- High performance for maximum EMI suppression

Electrical Specifications @ 25°C — Operating Temperature 0°C to +70°C

RoHS Compliant	Turns Ratios		EMI Fingers	LEDs ¹ L/R	Insertion Loss (dB TYP)	Return Loss (dB TYP) 100Ω ±15Ω					Crosstalk (dB TYP)			Common Mode Rejection (dB TYP)		Hipot (Vrms)
	TX	RX				1-65 MHz	1-10 MHz	10-30 MHz	30-60 MHz	60-80 MHz	1-30 MHz	30-60 MHz	60-100 MHz	1-50 MHz	50-150 MHz	
	Part No.															
	J1006F01PNL	1CT:1	1CT:1	No	G/Y	-1.0	-20	-16	-12	-10	-40	-35	-30	-30	-20	1500
	J1006F21NL	1CT:1	1CT:1	YES	NONE	-1.0	-20	-16	-12	-10	-40	-35	-30	-30	-20	1500
	J1011F01PNL	1CT:1	1CT:1	No	G/Y	-1.0	-20	-16	-12	-10	-40	-35	-30	-30	-20	1500
	J1011F21PNL	1CT:1	1CT:1	YES	G/Y	-1.0	-20	-16	-12	-10	-40	-35	-30	-30	-20	1500
	J1012F01CNL	1CT:1	1CT:1	No	Y/G	-1.0	-20	-16	-12	-10	-40	-35	-30	-30	-20	1500
	J1012F21CNL	1CT:1	1CT:1	YES	Y/G	-1.0	-20	-16	-12	-10	-40	-35	-30	-30	-20	1500
	J1012F21KNL	1CT:1	1CT:1	YES	G/G	-1.0	-20	-16	-12	-10	-40	-35	-30	-30	-20	1500
	J1012F21RNL	1CT:1	1CT:1	YES	RG/R	-1.0	-20	-16	-12	-10	-40	-35	-30	-30	-20	1500
	J1026F01NL	1CT:1	1CT:1	No	NONE	-1.0	-20	-16	-12	-10	-40	-35	-30	-30	-20	1500
	J1026F01PNL	1CT:1	1CT:1	No	G/Y	-1.0	-20	-16	-12	-10	-40	-35	-30	-30	-20	1500
	J1026F21CNL	1CT:1	1CT:1	YES	Y/G	-1.0	-20	-16	-12	-10	-40	-35	-30	-30	-20	1500
	JP006821UNL	1CT:1	1CT:1	YES	G_O/Y	-1.0	-20	-16	-12	-10	-40	-35	-30	-30	-20	1500
	JP011821UNL	1CT:1	1CT:1	YES	G_O/Y	-1.0	-20	-16	-12	-10	-40	-35	-30	-30	-20	1500
	JP026821UNL	1CT:1	1CT:1	YES	G_O/Y	-1.0	-20	-16	-12	-10	-40	-35	-30	-30	-20	1500

NOTES:

- LEDs Left/Right: G = green, Y = yellow, G_O = green/orange bi-color LED, R = LEDs with resistors.

RJ45 Durability Testing Rating

Part Number	Mating Force (MAX)	Unmating Force (MAX)	Durability	Plug to Jack Retention (MIN)
JP/J1 Series	5 lbs./2.268 kgs.	5 lbs./2.268 kgs.	750 Insertions	20 lbs./9.072 kgs.

RJ45 Material Specification

Part Number	Shield		Contact			Housing		MSL ² Rating
	Material	Finish	Material	Plating Area	Solder Area	Material	Specification	
JP/J1 Series	Brass	10-20m inches Nickel over 10-20m inches Brass	Phosphor Bronze	Nickel underplating and selective gold plating 15µ inches	Tin matte finish	Thermoplastic	UL 94 V-0	1

Notes: 1. Connector dimensions comply with FCC dimension requirements. 2. MSL = Moisture Sensitivity Level rating from 1 to 5 (highest rating = 1, lowest rating = 5).

PULSEJACK™

1x1 Tab-UP RJ45



A TECHNITROL COMPANY

www.pulseeng.com

J1 Series Mechanicals

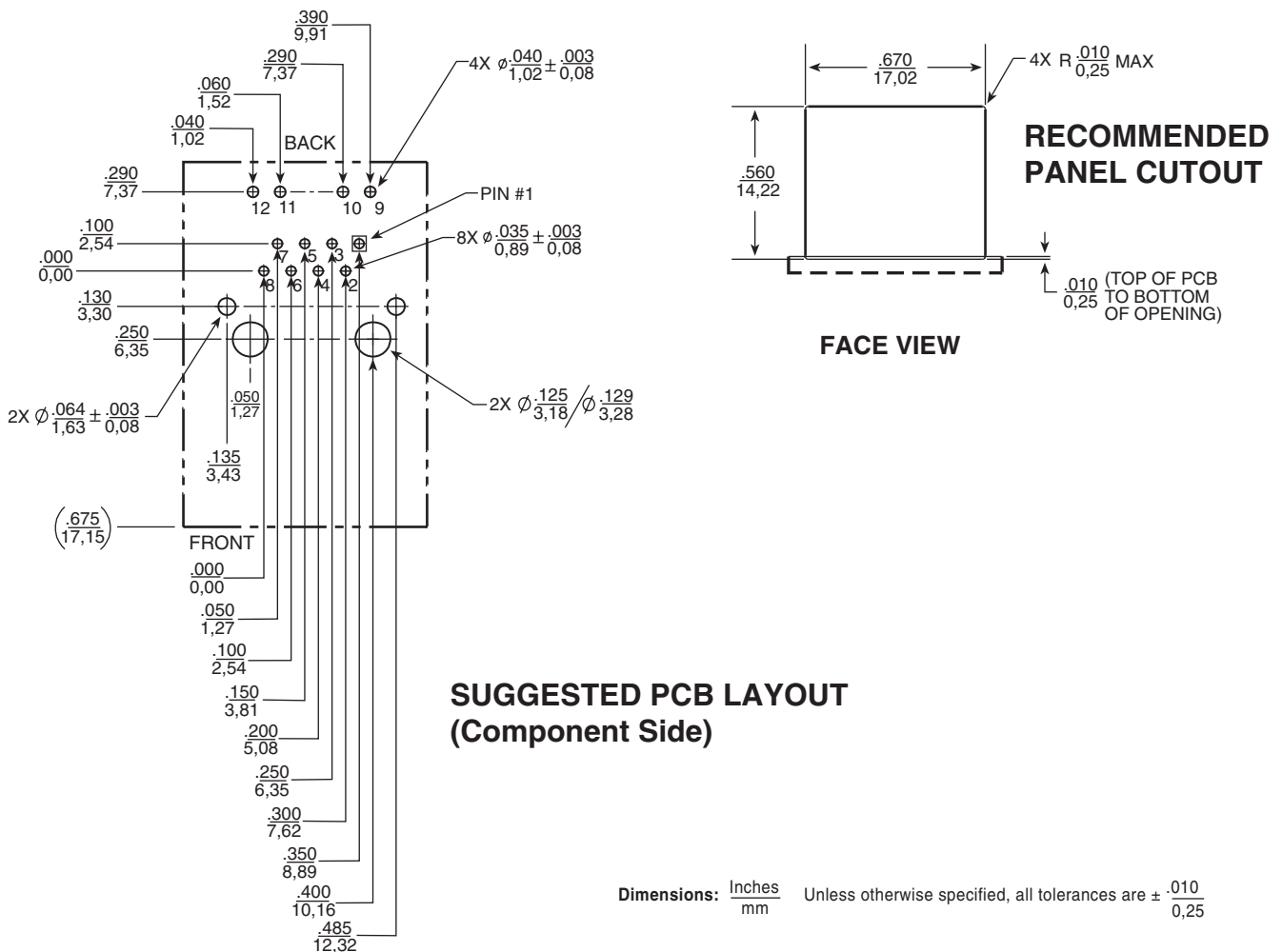
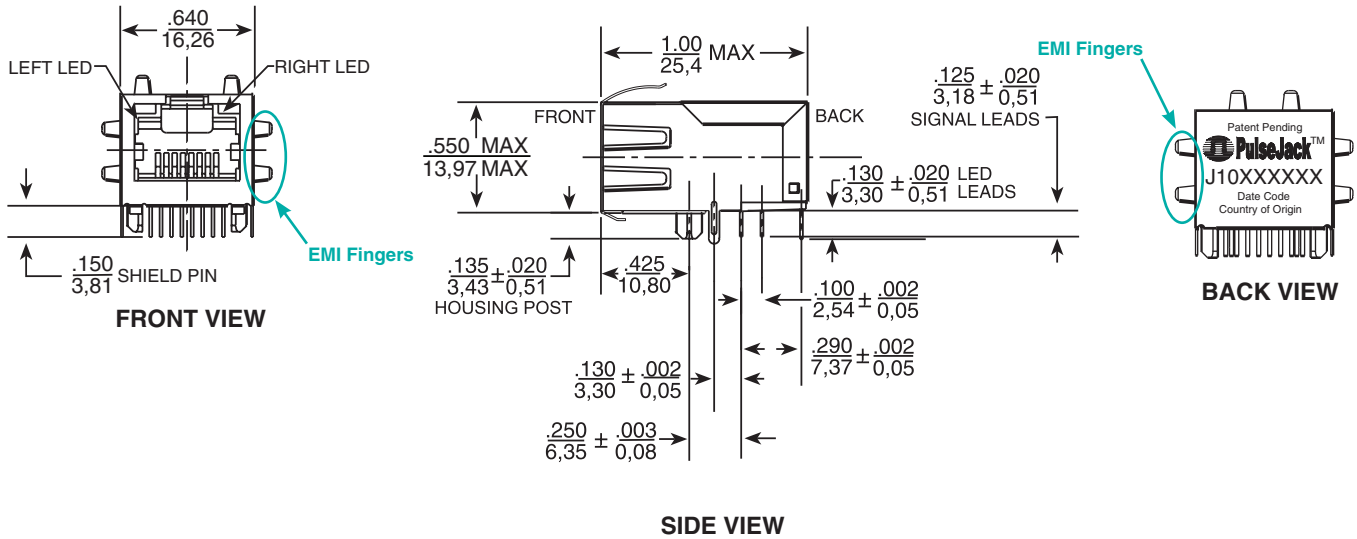

Dimensions: $\frac{\text{Inches}}{\text{mm}}$ Unless otherwise specified, all tolerances are $\pm \frac{.010}{0,25}$

J1 Series Electrical Schematics

J1006

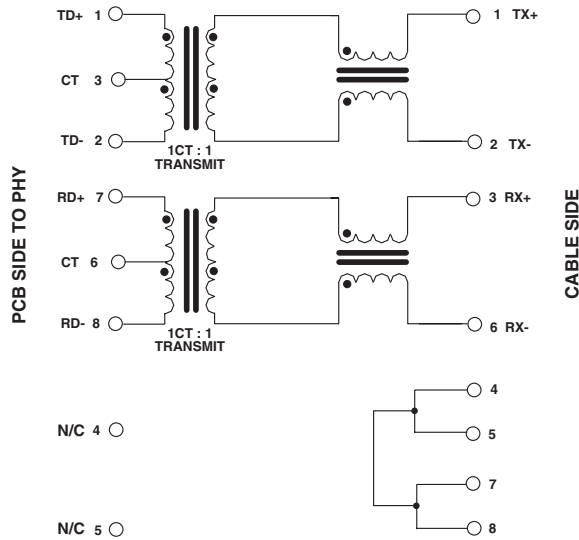

NOTE: Connect CHS GND to PCB ground.

J1011

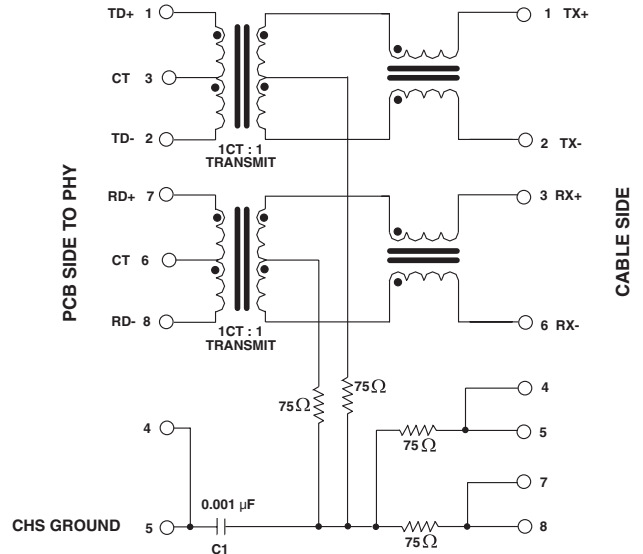

NOTE: Connect CHS GND to PCB ground.

J1012

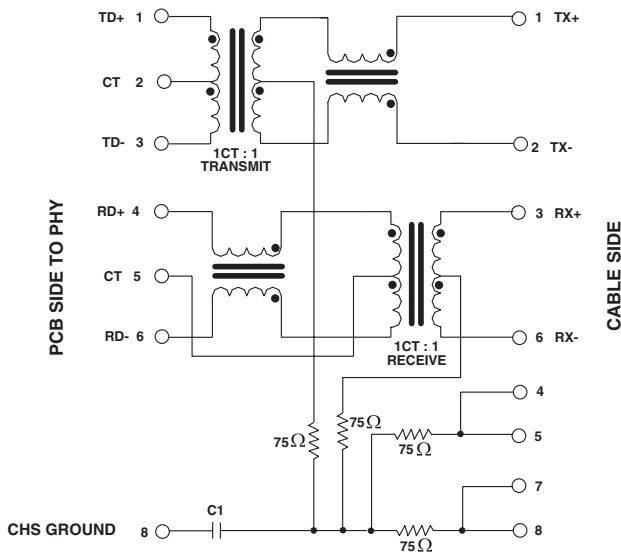

NOTE: Connect CHS GND to PCB ground.

J1026

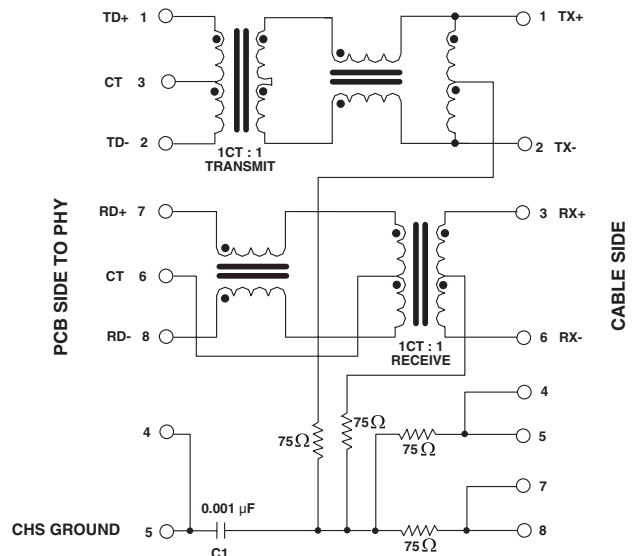

NOTE: Connect CHS GND to PCB ground.

LED = P

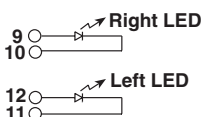

LED = L or R

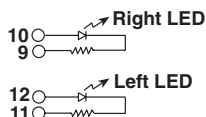

LED = C or K

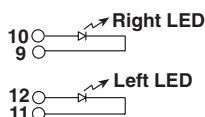

Standard LED	Wavelength	Forward* V(MAX)	(TYP)
Yellow	585 nm	2.5 V	2.1 V
Green	565 nm	2.5 V	2.2 V

* With a forward current of 20 mA

JP Series Mechanicals

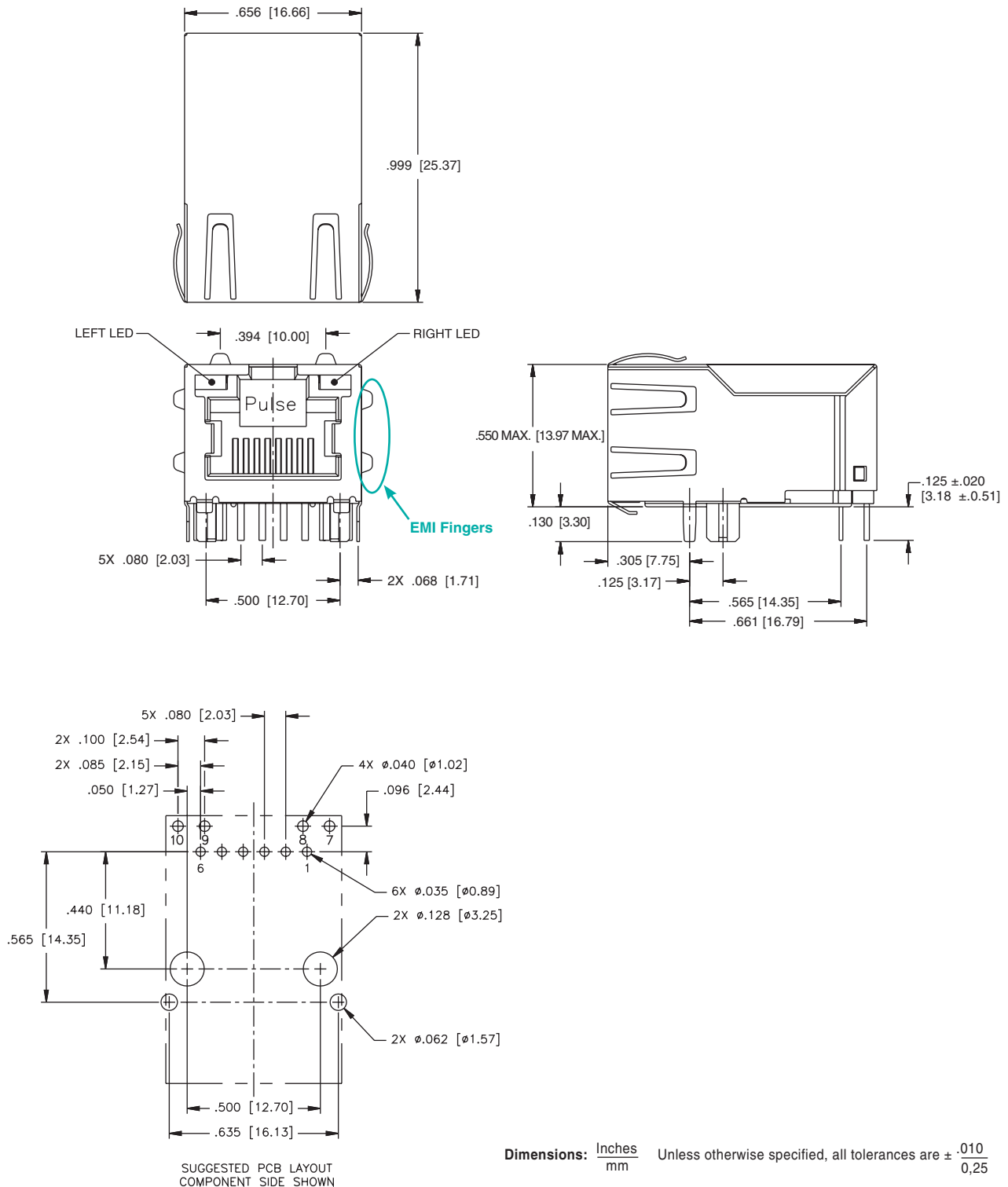



JP Series Electrical Schematics

JP006

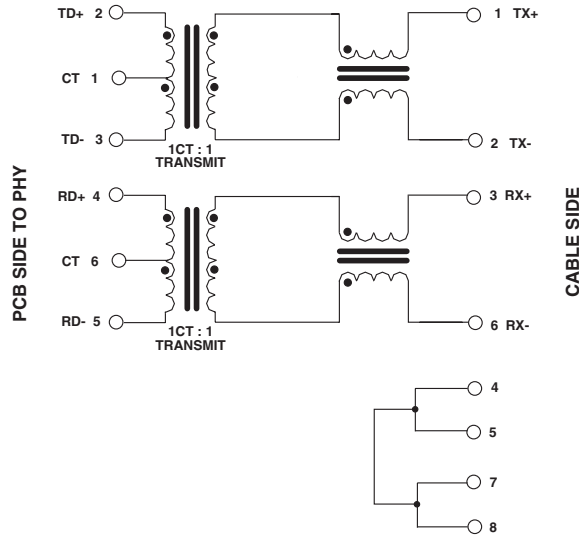

NOTE: Connect CHS GND to PCB ground.

JP011

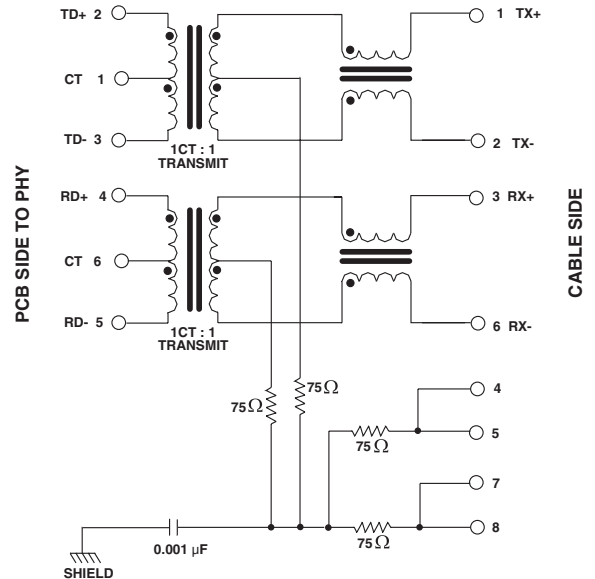

JP026

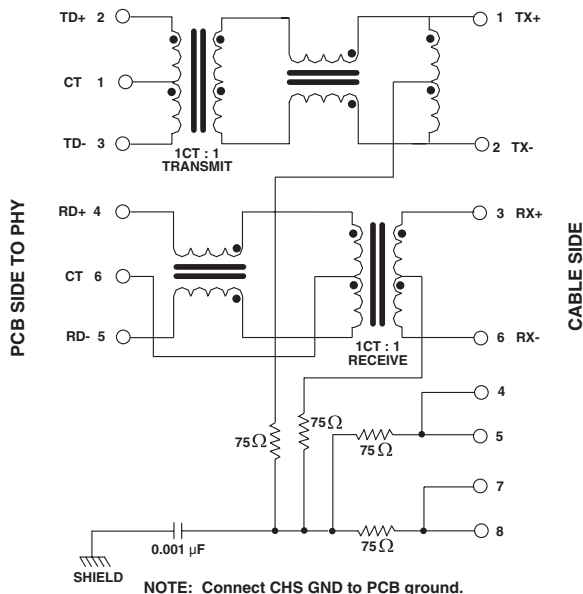

NOTE: Connect CHS GND to PCB ground.

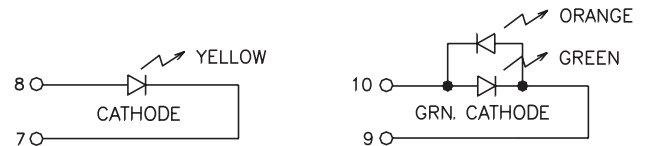

Standard LED	Wavelength	Forward* V (MAX)	(TYP)
Yellow	585 nm	2.5 V	2.1 - 2.2 V
Green	565 nm	2.5 V	2.1 - 2.2 V
Orange	610 nm	2.5 V	2.1 - 2.2 V

* With a forward current of 20 mA

For More Information:

Pulse Worldwide Headquarters

12220 World Trade Dr.
San Diego, CA 92128
U.S.A.

www.pulseeng.com

TEL: 858 674 8100

FAX: 858 674 8262

Pulse Europe

Einsteinstrasse 1
D-71083 Herrenberg
Germany

Tel: 49 7032 7806 116

Fax: 49 7032 7806 135

Pulse China Headquarters

No. 1
Industrial District
Changan, Dongguan
China

Tel: 86 769 85538070

Fax: 86 769 85538870

Pulse North China

Room 1503
XinYin Building
No. 888 YiShan Rd.
Shanghai 200233
China

Tel: 86 21 54643211/2

Fax: 86 21 54643210

Pulse South Asia

150 Kampong Ampat
#07-01/02
KA Centre
Singapore 368324

Tel: 65 6287 8998

Fax: 65 6280 0080

Pulse North Asia

No. 26
Kao Ching Rd.
Yang Mei Chen
Taoyuan Hsien
Taiwan, R. O. C.

Tel: 886 3 4641811

Fax: 886 3 4641911

Performance warranty of products offered on this data sheet is limited to the parameters specified. Data is subject to change without notice. Other brand and product names mentioned herein may be trademarks or registered trademarks of their respective owners.

© Copyright, 2006. Pulse Engineering, Inc. All rights reserved.



Компания «ЭлектроПласт» предлагает заключение долгосрочных отношений при поставках импортных электронных компонентов на взаимовыгодных условиях!

Наши преимущества:

- Оперативные поставки широкого спектра электронных компонентов отечественного и импортного производства напрямую от производителей и с крупнейших мировых складов;
- Поставка более 17-ти миллионов наименований электронных компонентов;
- Поставка сложных, дефицитных, либо снятых с производства позиций;
- Оперативные сроки поставки под заказ (от 5 рабочих дней);
- Экспресс доставка в любую точку России;
- Техническая поддержка проекта, помощь в подборе аналогов, поставка прототипов;
- Система менеджмента качества сертифицирована по Международному стандарту ISO 9001;
- Лицензия ФСБ на осуществление работ с использованием сведений, составляющих государственную тайну;
- Поставка специализированных компонентов (Xilinx, Altera, Analog Devices, Intersil, Interpoint, Microsemi, Aeroflex, Peregrine, Syfer, Eurofarad, Texas Instrument, Miteq, Cobham, E2V, MA-COM, Hittite, Mini-Circuits, General Dynamics и др.);

Помимо этого, одним из направлений компании «ЭлектроПласт» является направление «Источники питания». Мы предлагаем Вам помощь Конструкторского отдела:

- Подбор оптимального решения, техническое обоснование при выборе компонента;
- Подбор аналогов;
- Консультации по применению компонента;
- Поставка образцов и прототипов;
- Техническая поддержка проекта;
- Защита от снятия компонента с производства.



Как с нами связаться

Телефон: 8 (812) 309 58 32 (многоканальный)

Факс: 8 (812) 320-02-42

Электронная почта: org@eplast1.ru

Адрес: 198099, г. Санкт-Петербург, ул. Калинина, дом 2, корпус 4, литера А.