



TW

Hybrid D'Sub series



CONTENT

Specifications

• Connectors according to: MIL C24308 - NFC93425 - HE507

Materials and platings		Electrical Data	
Shells	Steel-Tin plating	Current rating	
Insulators	High temperature black thermoplastic	Signal contacts	7.5 A. with 10 A. peaks
Signal contacts	Female: machined bronze	Power contacts	
Material	Male: machined brass	PCB terminations	10 to 40 A.
Plating finish	16µ "Au over 79µ" Ni min.	Solder cup terminations	10 to 40 A.
Or	30µ "Au over 79µ" Ni min.	Crimp terminations	10 to 40 A.
Shielded contacts	Female: machined bronze	Shielded contacts	0.5 A.
Material	Male: machined brass	Voltage rating	
Plating		Signal and power contacts	300 V.R.M.S. at 50 Hz
Inner conductor	16µ "Au or 30µm Au over 79µ" Ni	Shielded contacts	150 V.R.M.S. at 50 Hz
Outer ring	10µ "Au over 79µ" Ni	Shielded contacts	
Terminations	Tinned	Frequency range	0-1 GHz
Except solder cup and crimp terminations	gold flash	Attenuation	0.2dB
Power contacts	Female: machined bronze	V. S. W. R.	1.4(+0.04/GHz)
Material	Male: machined brass	Characteristic impedance	50 Ohms
Plating		Dielectric withstanding voltage	≥ 1000 V.R.M.S. at 50Hz
Contacts	16µ "Au or 30µ" Au over 79µ" Ni	Insulation resistance	≥ 5000 M Ohms at 500 VDC
Terminations	Tinned	Contact resistance	≤ 5m Ohms
Except solder cup and crimp terminations	gold flash	Shell resistance (electrical grounding)	≤ 1m Ohm
Brackets	Steel-Tin plating		
Front jackscrews	Brass-Tin plating		
Rear clinch nuts	Brass-Tin plating		
Boardlocks	Bronze-Tin plating		
Stand-off	Brass-Tin plating		

Climatic Data		Mechanical data	
Operating temperature	-55°C + 155°C (with peaks up to 180°C)	Shells	With or without dimples
Damp heat	56 days (40°C - 95% HR)	Contact retention force in dielectric material	> 40N
Salt spray	48 hours	Maximum mating and unmating force	
		With dimples	E size = 70 N A size = 80 N B size = 100 N C size = 150 N D size = 180 N
		Without dimples	E size = 30 N A size = 50 N B size = 80 N C size = 120 N D size = 160 N
		Compatible with process	
		IR - Air convectioned	260° for 20 s.
		Resistance to solder iron heat	260°C for 30 s.
		Mating cycles	≥ 200 (classe II) or 500 (classe I)
		Blind mating system	Available upon request
		Polarization	Available with locking accessories Consult factory

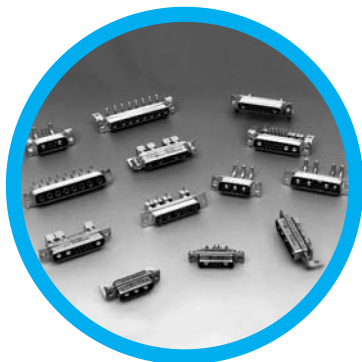

DESCRIPTION

Amphenol D'Sub TW Hybrid Series permits a mix of contacts including signal, power, shielded, high voltage and fiber optics in the same housing with 18 different contacts arrangements.

This economic series was first developed from our military series, and has improved features:

- new contacts
- new high temperature black thermoplastic insert
- PCB configurations come preloaded with fixed contacts and brackets.

These connectors are supplied with screw machined contacts which are fixed in the insulator.

A complete range of housings are also available for cable application.

A full range of arrangements compatible with reflow process

APPLICATIONS

- Commercial
- Medical
- Industrial
- Telecom
- Any application requiring optimization of space



Amphenol

TW / E1

Shell and contacts plating

CLASS II

0.4µm (16µ") Au contacts gold plating
200 mating cycles

Types	Shells and plating
77 TW	Tin plated shell <i>*Male and female</i>
717 TW	Tin plated shell with dimples <i>Male only</i>









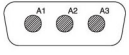
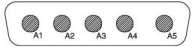
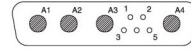
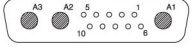
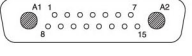
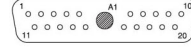

CLASS I

0.76µm (30µ") Au contacts gold plating
500 mating cycles

Types	Shells and plating
177 TW	Tin plated shell <i>*Male and female</i>
777 TW	Tin plated shell with dimples <i>Male only</i>

Housing arrangements

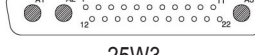
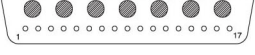
Male front view

Arrangement Shell size	 5W1 E	 7W2 A	 11W1 A
Arrangement Shell size	 3W3 A	 5W5 B	 9W4 B
Arrangement Shell size	 13W3 B	 17W2 B	 21W1 B
Arrangement Shell size	 27W2 C	 13W6 C	 17W5 C
Arrangement Shell size	 21W4 C	 8W8 C	 25W3 C
Arrangement Shell size	 24W7 D	 36W4 D	 43W2 D

Shell size dimensions



Shell size	Contact P: Pin S: Socket	A ±0.25 (±.010)	B 0/-0.20 (0/-0.008)	B' +0.20/0 (+.008/0)	C ±0.10 (±.004)	D 0/-0.25 (0/-0.010)	D' +0.25/0 (+.010/0)	E ±0.20 (±.008)	F +0.05/-0.20 (+.002/-0.008)	F' +0.10/-0.20 (+.004/-0.008)	G +0.10/-0.20 (+.004/-0.008)	G' ±0.10 (±.004)	H +0.10/-0.40 (+.004/-0.016)	J 0/-0.50 (0/-0.020)
E	P	30.7 (1.209")		16.8 (.661")	25.0 (.984")		8.2 (.323")	12.4 (.488")		10.9 (.429")		5.9 (.232")	19.4 (.764")	11.0 (.433")
	S		16.4 (.646")			8.0 (.315")			11.1 (.437")		6.2 (.244")			
A	P	39.0 (1.535")		25.1 (.988")	33.3 (1.311")		8.2 (.323")	12.4 (.488")		10.9 (.429")		5.9 (.232")	27.7 (1.091")	11.0 (.433")
	S		24.8 (.976")			8.0 (.315")			11.1 (.437")		6.2 (.244")			
B	P	52.9 (2.083")		38.8 (1.528")	47.0 (1.850")		8.2 (.323")	12.4 (.488")		11.0 (.433")		5.8 (.228")	41.4 (1.630")	11.0 (.433")
	S		38.5 (1.513")			8.0 (.315")			11.1 (.437")		6.2 (.244")			
C	P	69.2 (2.724")		55.3 (2.177")	63.5 (2.500")		8.2 (.323")	12.4 (.488")		11.0 (.433")		5.8 (.228")	57.9 (2.280")	11.0 (.433")
	S		54.9 (2.161")			8.0 (.315")			11.1 (.437")		6.2 (.244")			
D	P	66.8 (2.630")		52.7 (2.075")	61.1 (2.406")		11.0 (.433")	15.2 (.598")		11.0 (.433")		5.8 (.228")	55.5 (2.185")	13.8 (.543")
	S		52.5 (2.067")			10.9 (.429")			11.1 (.437")		6.2 (.244")			

Panel cutouts

Optimal cutout for rear mounting

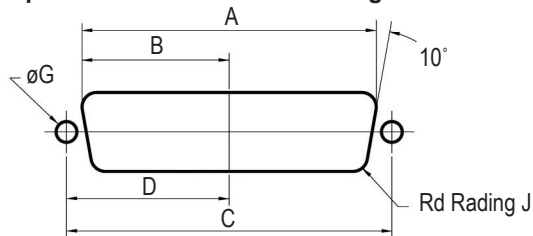

Standard cutout

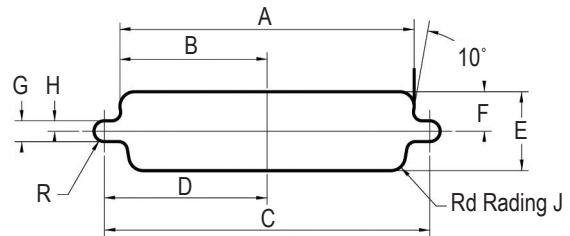

Shell size	Mounting method	A ±0.20 (±.008)	B ±0.20 (±.008)	C ±0.20 (±.008)	D ±0.20 (±.008)	E ±0.20 (±.008)	F ±0.20 (±.008)	G ±0.20 (±.008)	H ±0.20 (±.008)	J ±0.20 (±.008)
E	Front	22.2 (.874")	11.1 (.437")	25.0 (.984")	12.5 (.492")	13.0 (.512")	6.5 (.256")	3.0 (.118")	1.5 (.059")	2.1 (.083")
	Rear	20.5 (.807")	10.2 (.402")							3.4 (.134")
A	Front	30.5 (1.201")	15.3 (.602")	33.3 (1.311")	16.7 (.657")	13.0 (.512")	6.5 (.256")	3.0 (.118")	1.5 (.059")	2.1 (.083")
	Rear	28.8 (1.134")	14.4 (.567")							3.4 (.134")
B	Front	44.3 (1.744")	22.1 (.870")	47.0 (1.850")	23.5 (.925")	13.0 (.512")	6.5 (.256")	3.0 (.118")	1.5 (.059")	2.1 (.083")
	Rear	42.5 (1.673")	21.3 (.839")							3.4 (.134")
C	Front	60.7 (2.390")	30.4 (1.197")	63.5 (2.500")	31.7 (1.248")	13.0 (.512")	6.5 (.256")	3.0 (.118")	1.5 (.059")	2.1 (.083")
	Rear	59.1 (2.327")	29.5 (1.161")							3.4 (.134")
D	Front	58.3 (2.295")	29.2 (1.150")	61.1 (2.406")	30.6 (1.205")	15.8 (.622")	7.9 (.311")	3.0 (.118")	1.5 (.059")	2.1 (.083")
	Rear	56.3 (2.217")	28.2 (1.110")							3.4 (.134")

Straight connector footprint



Signal tail 0.6 mm Dia. (.0236")
 1.6 mm (.063")PCB
 For other PCB thickness: consult factory.

Description		Dimensions	
		a	b
Power (.126" tail dia.)	1	4.80 mm (.198")	7.2 mm (.283")
Power (.0787" tail dia.)	1	4.80 mm (.198")	7.2 mm (.283")
Shielded	3	4.00 mm (.157")	7.2 mm (.283")
Signal	2	5.00 mm (.196")	11.50 mm (.453")

Straight contact combinations

Arrangement with signal contacts

See above dimensions	Size 8 and 20 Contacts
P 3SY	Power 3.2 mm DIA. (.126") (20 to 40 A) and signal
P 2SY	Power 2 mm DIA. (.0787") (10 to 20 A) and signal
CSY	Shielded and signal
SY	Signal only
No reference	Signal (Size 20) with solder cup terminations <i>Housing preloaded with contacts</i>

Arrangement without signal contacts 3W3 - 5W5 - 8W8

See above dimensions	Size 8 Contacts
P 3Y	Power only 3.2 mm DIA. (.126") (20 to 40 A)
P 2Y	Power only 2 mm DIA. (.0787") (10 to 20 A)
CY	Shielded only

Right angle connector footprint

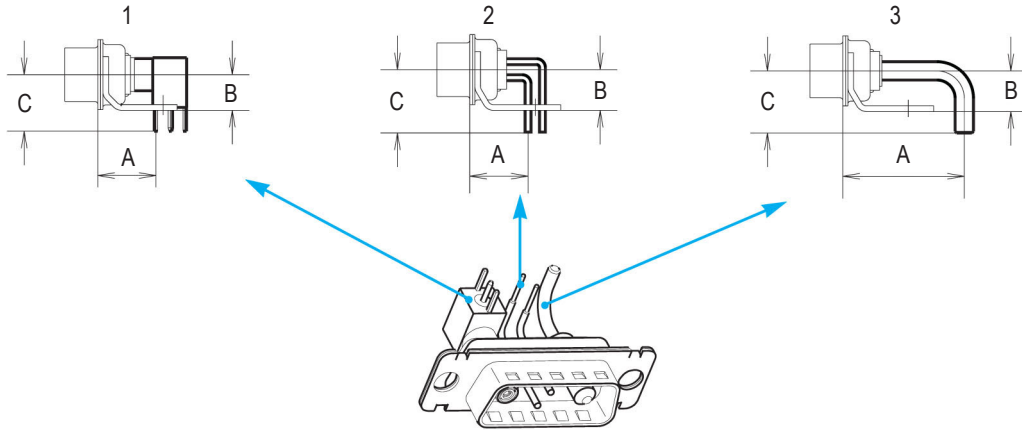

Signal tail 0.6 mm Dia. (.0236")
 1.6 mm (.063") PCB
 For other PCB thickness: consult factory.

Description		Europe			Mix			MIL		
		a	b	c	a	b	c	a	b	c
Shielded	1	-	-	-	10.30mm (.406")	6.30mm (.248")	10.00mm (.394")	10.30mm (.406")	6.30mm (.248")	10.00mm (.394")
Signal	2	10.30mm (.406")	7.20mm (.283")	11.20mm (.441")	10.30mm (.406")	6.30mm (.248")	9.50mm (.374")	8.10mm (.319")	6.30mm (.248")	9.50mm (.374")
Power (.0787" tail dia.)	3	11.57mm (.456")	7.20mm (.283")	10.50mm (.413")	11.57mm (.456")	6.30mm (.248")	9.50mm (.374")	9.52mm (.375")	6.30mm (.248")	9.50mm (.374")
Power (.126" tail dia.)	3	21.46mm (.845")	7.20mm (.283")	10.50mm (.413")	21.46mm (.845")	6.30mm (.248")	9.50mm (.374")	21.46mm (.845")	6.30mm (.248")	9.50mm (.374")

Note: above dimensions correspond to sizes E to C. Consult factory for D sizes.
 Connector comes equipped with contacts and brackets.

Right angle contacts combinations

Arrangement with signal contacts

European footprint	Mixed footprint	MIL (U.S.) footprint	Size 8 and 20 Contacts
EP3SV	HP3SV	MP3SV	Power 3.2 mm DIA. (.126") (20 to 40 A) and signal
EP2SV	HP2SV	MP2SV	Power 2 mm DIA. (.0787") (10 to 20 A) and signal
-	HCSV	MCSV	Shielded and signal
ESV	HSV	MSV	Signal only

Arrangement without signal contacts 3W3 - 5W5 - 8W8

European footprint	Mixed footprint	MIL (U.S.) footprint	Size 8 contacts only
EP3V	HP3V	MP3V	Power only 3.2 mm DIA. (.126") (20 to 40 A)
EP2V	HP2V	MP2V	Power only 2.0 mm DIA. (.0787") (10 to 20 A)
-	HCV	MCV	Shielded only

Mounting options

Right angle version

Connectors come equipped with metal brackets

BLANK: 3.10mm (.122") dia mounting hole

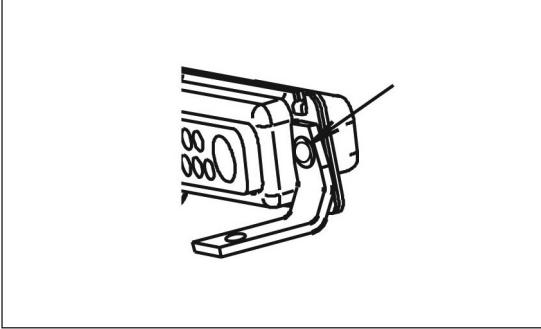

RM6: metal brackets + boardlock

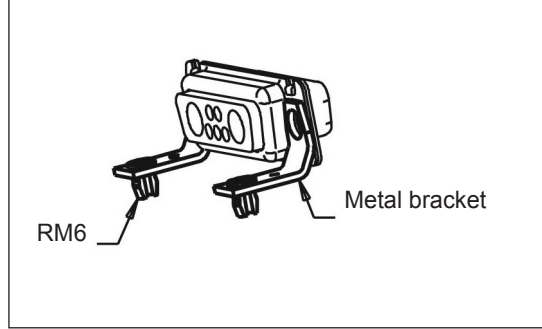

Straight version

BLANK: 3.10mm (.122") dia mounting hole

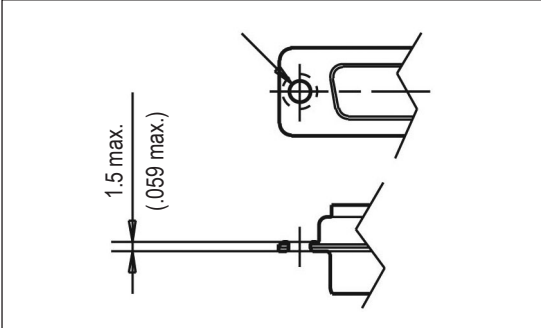

RM54: RM5 4.40 threaded
RM53: RM5 M3 threaded

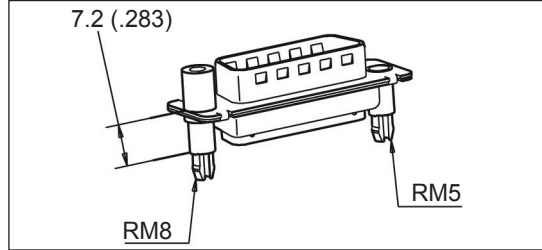

RM84: RM8 4.40 threaded
RM83: RM8 M3 threaded

A514: blind mating system

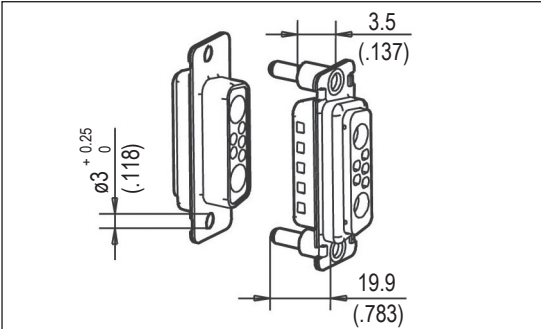

FM: float mounting system

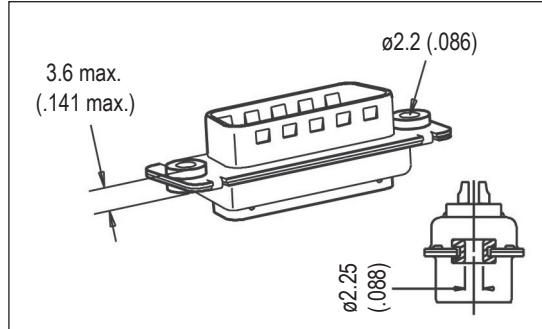

Straight and right angle version

4R: 4.40 rear nut

3R: M3 rear nut

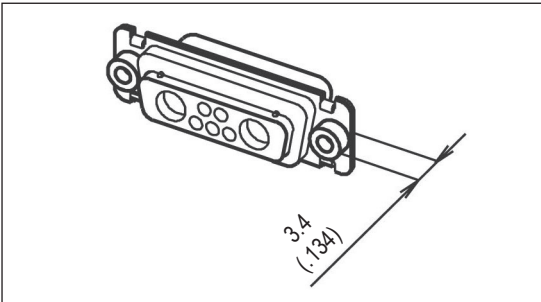

4F: 4.40 front female screwlock

3F: M3 front female screwlock

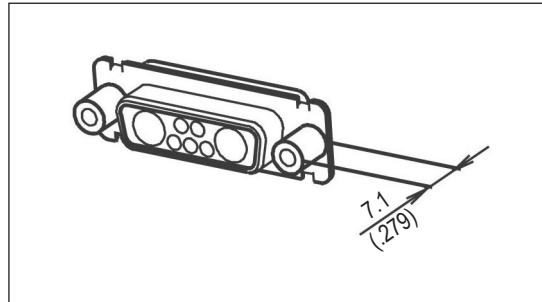

High power contacts



Solder cup version

Technical drawings of solder cup version contacts. The left drawing shows a side view with dimensions 22 (.866), øA, and øB. The right drawing shows a top view with dimensions 22 (.866), øA, and øB. The rightmost drawing shows a side view of the solder cup with a dimension of 16 (.622).

P/N		Current	Dimensions	
Plug	Socket		A mm (inch)	B mm (inch)
L 17DM 53745-8	L 17DM 53744-7	10 to 20 Amp.	1.80 (.071")	2.55 (.100")
L 17DM 53745-7	L 17DM 53744-6	20 to 30 Amp.	2.80 (.110")	3.70 (.145")
L 17DM 53745-1	L 17DM 53744-1	30 to 40 Amp.	4.80 (.189")	5.60 (.220")

Trim dimensions: 7.5 mm (.295")

Crimp version

Technical drawings of crimp version contacts. The left drawing shows a side view with dimensions 22 (.866), øA, and øB. The right drawing shows a top view with dimensions 22 (.866), øA, and øB. The rightmost drawing shows a side view of the crimp with a dimension of 16 (.622).

P/N		Current	Dimensions	
Plug	Socket		A mm (inch)	B mm (inch)
L 17DM 53745-208	L 17DM 53744-207	10 to 20 Amp.	1.80 (.071")	2.55 (.100")
L 17DM 53745-207	L 17DM 53744-206	20 to 30 Amp.	2.80 (.110")	3.70 (.145")
L 17DM 53745-201	L 17DM 53744-201	30 to 40 Amp.	4.80 (.189")	5.60 (.220")

Trim dimensions: 7.5 mm (.295")

**Crimping tool for all sizes
L17D479SP**



Extraction tool for sizes 8 cts



Straight shielded contacts

Crimp ferrule and inner solder

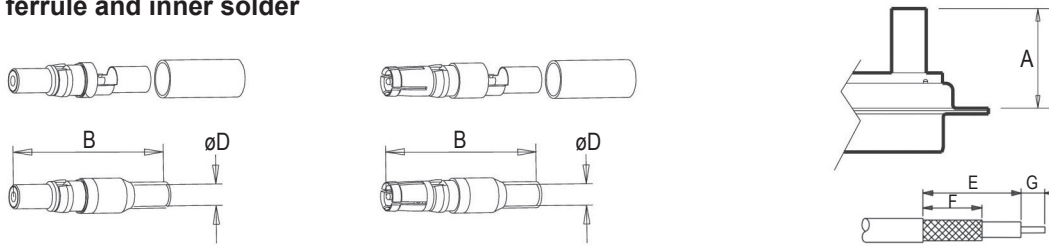

Type	P/N	Dimensions (inch)			Cable - RG	Trim dimensions (inch)		
		A Max	B	D		E	F	G
plug	L17DM 53740	18.8 (740")	23.6 (.929")	1.0 (.039")	178 B/U	7.9 (.311")	6.3 (.248")	2 (.078")
plug	L17DM 53740-1	18.8 (740")	23.6 (.929")	1.7 (.066")	179 B/U 316 B/U	7.9 (.311")	6.3 (.248")	2 (.078")
plug	L17DM 53740-3	21.5 (846")	23.6 (.929")	2.8 (.110")	180 B/U	9.5 (.374")	7.9 (.311")	2 (.078")
plug	L17DM 53740-5	21.5 (846")	23.6 (.929")	3.2 (.126")	58 C/U	9.5 (.374")	7.9 (.311")	2 (.078")
socket	L17DM 53742	18.8 (740")	23.6 (.929")	1.0 (.039")	178 B/U	7.9 (.311")	6.3 (.248")	2 (.078")
socket	L17DM 53742-1	18.8 (740")	23.6 (.929")	1.7 (.066")	179 B/U 316 B/U	7.9 (.311")	6.3 (.248")	2 (.078")
socket	L17DM 53742-3	21.5 (846")	23.6 (.929")	2.8 (.110")	180 B/U	9.5 (.374")	7.9 (.311")	2 (.078")
socket	L17DM 53742-5	21.5 (846")	23.6 (.929")	3.2 (.126")	58 C/U	9.5 (.374")	7.9 (.311")	2 (.078")

Ferrule and inner solder

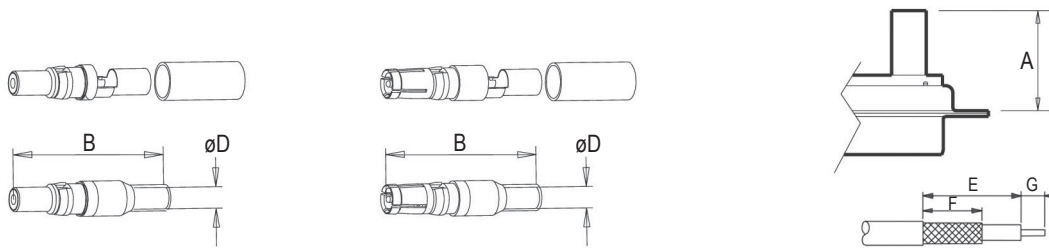

Type	P/N	Dimensions (inch)			Cable - RG	Trim dimensions (inch)		
		A Max	B	D		E	F	G
short plug	L17DM 53740-5000	17.0 (669")	21.8 (.858")	1.0 (.039")	178 B/U	7.9 (.311")	6.3 (.248")	2 (.078")
plug	L17DM 53740-5001	18.8 (740")	23.6 (.929")	1.7 (.066")	179 B/U 316 B/U	7.9 (.311")	6.3 (.248")	2 (.078")
plug	L17DM 53740-5002	21.5 (846")	26.3 (1.035")	2.8 (.110")	180 B/U	9.5 (.374")	7.9 (.311")	2 (.078")
plug	L17DM 53740-5005	21.5 (846")	26.3 (1.035")	3.2 (.126")	58 C/U	9.5 (.374")	7.9 (.311")	2 (.078")
plug	L17DM 53740-5008	18.8 (740")	23.6 (.929")	1.0 (.039")	178 B/U	7.9 (.311")	6.3 (.248")	2 (.078")
short socket	L17DM 53742-5000	17.0 (669")	21.8 (.858")	1.0 (.039")	178 B/U	7.9 (.311")	6.3 (.248")	2 (.078")
socket	L17DM 53742-5001	18.8 (740")	23.6 (.929")	1.7 (.066")	179 B/U 316 B/U	7.9 (.311")	6.3 (.248")	2 (.078")
socket	L17DM 53742-5002	21.5 (846")	26.3 (1.035")	2.8 (.110")	180 B/U	9.5 (.374")	7.9 (.311")	2 (.078")
socket	L17DM 53742-5004	21.5 (846")	26.3 (1.035")	3.2 (.126")	58 C/U	9.5 (.374")	7.9 (.311")	2 (.078")
socket	L17DM 53742-50060	18.8 (740")	23.6 (.929")	1.0 (.039")	178 B/U	7.9 (.311")	6.3 (.248")	2 (.078")

Right angled shielded contact

Crimp ferrule and inner solder

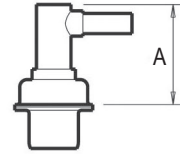
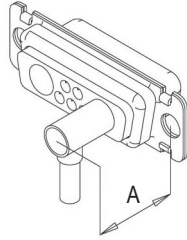

Type	P/N	Dimensions (inch)			Cable - RG	Trim dimensions (inch)		
		A Max	B	D		E	F	G
plug	L17DM 53741	13.5 (.531")	18.6 (.732")	1.0 (.039")	178 B/U	9.5 (.374")	5.9 (.232")	1.6 (.062")
plug	L17DM 53741-1	13.5 (.531")	18.6 (.732")	1.7 (.066")	179 B/U 316 B/U	9.5 (.374")	5.9 (.232")	1.6 (.062")
plug	L17DM 53741-3	13.5 (.531")	18.6 (.732")	2.8 (.110")	180 B/U	10.7 (.421")	7.9 (.311")	2.4 (.094")
plug	L17DM 53741-4	13.5 (.531")	18.6 (.732")	3.2 (.126")	58 C/U	10.7 (.421")	7.9 (.311")	2.4 (.094")
socket	L17DM 53743-2	13.5 (.531")	18.6 (.732")	1.0 (.039")	178 B/U	9.5 (.374")	5.9 (.232")	1.6 (.062")
socket	L17DM 53743-3	13.5 (.531")	18.6 (.732")	1.7 (.066")	179 B/U 316 B/U	9.5 (.374")	5.9 (.232")	1.6 (.062")
socket	L17DM 53743-5	13.5 (.531")	18.6 (.732")	2.8 (.110")	180 B/U	10.7 (.421")	7.9 (.311")	2.4 (.094")
socket	L17DM 53743-6	13.5 (.531")	18.6 (.732")	3.2 (.126")	58 C/U	10.7 (.421")	7.9 (.311")	2.4 (.094")

Ferrule and inner solder

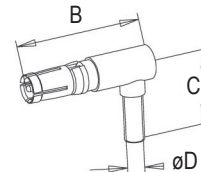
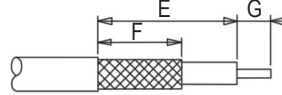
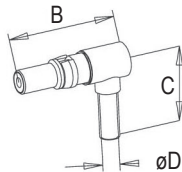

Type	P/N	Dimensions (inch)			Cable - RG	Trim dimensions (inch)		
		A Max	B	D		E	F	G
plug	L17DM 53741-5000	13.5 (.531")	18.6 (.732")	1.0 (.039")	178 B/U	9.5 (.374")	5.9 (.232")	1.6 (.062")
plug	L17DM 53741-5001	13.5 (.531")	18.6 (.732")	1.7 (.066")	179 B/U 316 B/U	9.5 (.374")	5.9 (.232")	1.6 (.062")
plug	L17DM 53741-5003	13.5 (.531")	18.6 (.732")	2.8 (.110")	180 B/U	10.7 (.421")	7.9 (.311")	2.4 (.094")
plug	L17DM 53741-5004	13.5 (.531")	18.6 (.732")	3.2 (.126")	58 C/U	10.7 (.421")	7.9 (.311")	2.4 (.094")
socket	L17DM 53743-5000	13.5 (.531")	18.6 (.732")	1.0 (.039")	178 B/U	9.5 (.374")	5.9 (.232")	1.6 (.062")
socket	L17DM 53743-5001	13.5 (.531")	18.6 (.732")	1.7 (.066")	179 B/U 316 B/U	9.5 (.374")	5.9 (.232")	1.6 (.062")
socket	L17DM 53743-5003	13.5 (.531")	18.6 (.732")	2.8 (.110")	180 B/U	10.7 (.421")	7.9 (.311")	2.4 (.094")
socket	L17DM 53743-5004	13.5 (.531")	18.6 (.732")	3.2 (.126")	58 C/U	10.7 (.421")	7.9 (.311")	2.4 (.094")

Crimping tool

Hand crimp tool

227-0944 (without dies) (M 22 520/5-01)

RG cables	MIL reference	Amphenol P/N	dim. between 2 flat surface	
			cavity A	cavity B
RG 58 C/U	M 22 520/5-05	227 1221-05	5.41	-
RG 178 B/U	M 22 520/5-03	227 1221-03	-	2.67
RG 179 B/U	M 22 520/5-03	227 1221-03	3.25	-
RG 180 B/U	M 22 520/5-05	227 1221-05	-	4.52

Extraction tool

Extraction tool for sizes 8 cts

L17D429SP



Cabling instructions for shielded contacts

Straight crimp shielded contacts:



inner solder contact outer crimp contact



Right angle crimp shielded contacts:



inner solder contact outer crimp contact



Assembly method

- Slide the outer ring over the cable jacket. Trim the cable according to the recommended dimensions.
- Insert the cable dielectric and the center conductor inside the inner sleeve.
- Solder the central conductor to the shielded center contacts.
- Slide the outer ring towards the inner sleeve and recover the braid.
- Using crimp hand tool equipped with the appropriate dies, crimp in the area defined.

Solder straight shielded contacts:



Solder right angle shielded contacts:

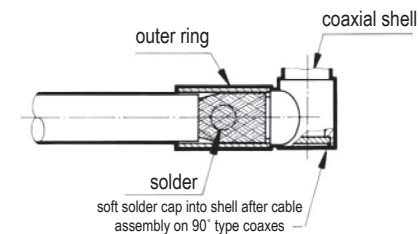

Assembly method

- Slide the outer ring over the cable jacket. Trim the cable according to the recommended dimensions.
- Insert the cable dielectric and the center conductor inside the inner sleeve.
- Solder the central conductor to the shielded center contacts.
- Slide the outer ring towards the inner sleeve and recover the braid.
- Solder by introducing metal through the outer ring hole.

How to build your part number

L

... TW ...

RoHS Compliant

Contacts and Shell		
Contact Plating	Shell	
	Tinned	Tinned & Indents; Plug only
0.4µm(16µ") Au	77	717
0.76µm(30µ") Au	177	777

Shell size and Configuration:
 E5W1, A3W3, A7W2, A11W1, B5W5, B9W4, B13W3,
 B17W2, B21W1, C8W8, C13W6, C17W5, C21WA4
 C25W3, C27W2, D24W7, D36W4, D43W2

Gender:
 P: Pin
 S: Socket

Special Deviations
 Please consult factory

Board Mounting Options
For Straight
Blank: .120"(3.05mm) Clear Hole
RM53: M3 Threaded (panel side)
 standoff with boardlock
RM54: 4-40UNC Threaded (panel side)
 standoff with boardlock
RM84: Non-Removable M3 screwlock,
 with standoff and boardlock
For Right Angle
RM6: Metal bracket with boardlocks

Contacts:
For straight
BLANK: Solder-cup signal contacts only
P3SY: 20-40 Amp power & signal mix
P2SY: 10-20 Amp power & signal mix
CSY: Coax & signal mix
SY: Signal only
P3Y: 20-40 Amp power only (3W3, 5W5, 8W8)
P2Y: 10-20 Amp power only (3W3, 5W5, 8W8)
CY: Coax only (3W3, 5W5, 8W8)

For right angle
MP3SV: US Footprint, 20-40 Amp power & signal mix
MP2SV: US Footprint, 10-20 Amp power & signal mix
MCSV: US Footprint, Coax & signal mix
MSV: US Footprint, Signal only
MP3V: US Footprint, 20-40 Amp power only (3W3, 5W5, 8W8)
MP2V: US Footprint, 10-20 Amp power only (3W3, 5W5, 8W8)
MCV: US Footprint, Coax only (3W3, 5W5, 8W8)
EP3SV: European Footprint, 20-40 Amp power & signal mix
EP2SV: European Footprint, 10-20 Amp power & signal mix
ESV: European Footprint, Signal only
EP3V: European Footprint, 20-40 Amp power only (3W3, 5W5, 8W8)
EP2V: European Footprint, 10-20 Amp power only (3W3, 5W5, 8W8)
HP3SV: Mixed Footprint, 20-40 Amp power & signal mix
HP2SV: Mixed Footprint, 10-20 Amp power & signal mix
HCSV: Mixed Footprint, Coax & signal mix
HSV: Mixed Footprint, Signal only
HP3V: Mixed Footprint, 20-40 Amp power only (3W3, 5W5, 8W8)
HP2V: Mixed Footprint, 10-20 Amp power only (3W3, 5W5, 8W8)
HCV: Mixed Footprint, Coax only (3W3, 5W5, 8W8)

Panel Mounting Options
For right angle & cable mount
Blank: .120"(3.05mm) Clear Hole
3F: M3 Front Screwlock
3R: M3 Rear Threaded Insert
4F: #4-40 Front Screwlock
4R: #4-40 Threaded Rear Insert
FM: Float mount system
A514: Blind Mate Guide Pin



Компания «ЭлектроПласт» предлагает заключение долгосрочных отношений при поставках импортных электронных компонентов на взаимовыгодных условиях!

Наши преимущества:

- Оперативные поставки широкого спектра электронных компонентов отечественного и импортного производства напрямую от производителей и с крупнейших мировых складов;
- Поставка более 17-ти миллионов наименований электронных компонентов;
- Поставка сложных, дефицитных, либо снятых с производства позиций;
- Оперативные сроки поставки под заказ (от 5 рабочих дней);
- Экспресс доставка в любую точку России;
- Техническая поддержка проекта, помощь в подборе аналогов, поставка прототипов;
- Система менеджмента качества сертифицирована по Международному стандарту ISO 9001;
- Лицензия ФСБ на осуществление работ с использованием сведений, составляющих государственную тайну;
- Поставка специализированных компонентов (Xilinx, Altera, Analog Devices, Intersil, Interpoint, Microsemi, Aeroflex, Peregrine, Syfer, Eurofarad, Texas Instrument, Miteq, Cobham, E2V, MA-COM, Hittite, Mini-Circuits, General Dynamics и др.);

Помимо этого, одним из направлений компании «ЭлектроПласт» является направление «Источники питания». Мы предлагаем Вам помощь Конструкторского отдела:

- Подбор оптимального решения, техническое обоснование при выборе компонента;
- Подбор аналогов;
- Консультации по применению компонента;
- Поставка образцов и прототипов;
- Техническая поддержка проекта;
- Защита от снятия компонента с производства.



Как с нами связаться

Телефон: 8 (812) 309 58 32 (многоканальный)

Факс: 8 (812) 320-02-42

Электронная почта: org@eplast1.ru

Адрес: 198099, г. Санкт-Петербург, ул. Калинина, дом 2, корпус 4, литера А.