

Description

The 9DBU0241 is a member of IDT's 1.5V Ultra-Low-Power (ULP) PCIe family. It has integrated output terminations providing $Z_o=100\Omega$ for direct connection to 100ohm transmission lines. The device has 2 output enables for clock management.

Recommended Application

1.5V PCIe Gen1-2-3 Zero-Delay/Fan-out Buffer (ZDB/FOB)

Output Features

- 2 – 1-167MHz Low-Power (LP) HCSL DIF pairs
w/ $Z_o=100\Omega$

Key Specifications

- DIF cycle-to-cycle jitter <50ps
- DIF output-to-output skew <50ps
- DIF phase jitter is PCIe Gen1-2-3 compliant
- DIF bypass mode *additive* phase jitter is <300fs rms for PCIe Gen3
- DIF bypass mode *additive* phase jitter <350fs rms for 12k-20MHz

Features/Benefits

- Direct connection to 100 Ω transmission lines; saves 8 resistors compared to standard HCSL outputs
- 35mW typical power consumption in PLL mode; eliminates thermal concerns
- Spread Spectrum (SS) compatible; allows SS for EMI reduction
- OE# pins; support DIF power management
- HCSL-compatible differential input; can be driven by common clock sources
- SMBus-selectable features; optimize signal integrity to application
 - slew rate for each output
 - differential output amplitude
- Pin/SMBus selectable PLL bandwidth and PLL Bypass; optimize PLL to application
- Outputs blocked until PLL is locked; clean system start-up
- Device contains default configuration; SMBus interface not required for device control
- 3.3V tolerant SMBus interface works with legacy controllers
- Space saving 24-pin 4x4mm VFQFPN; minimal board space

Block Diagram

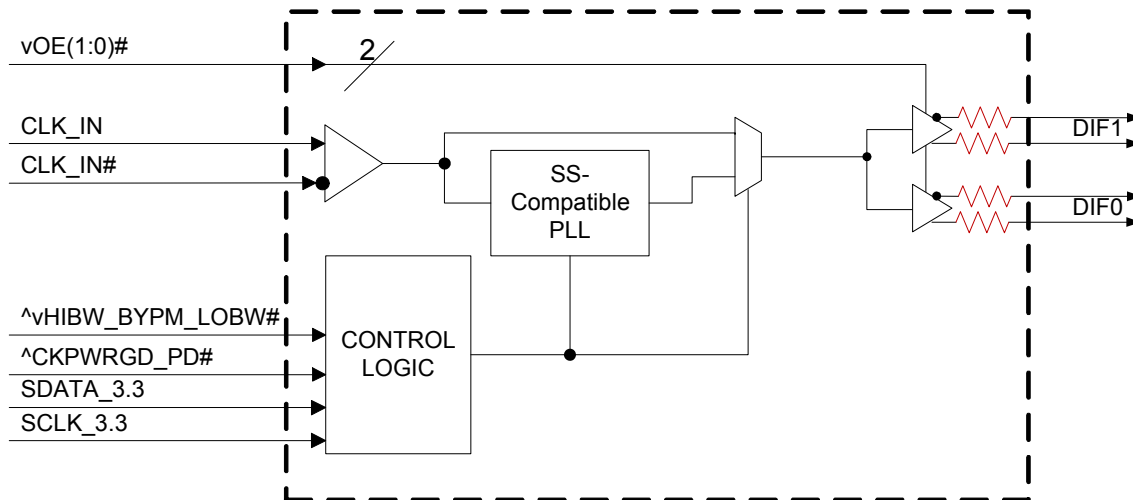

Pin Configuration

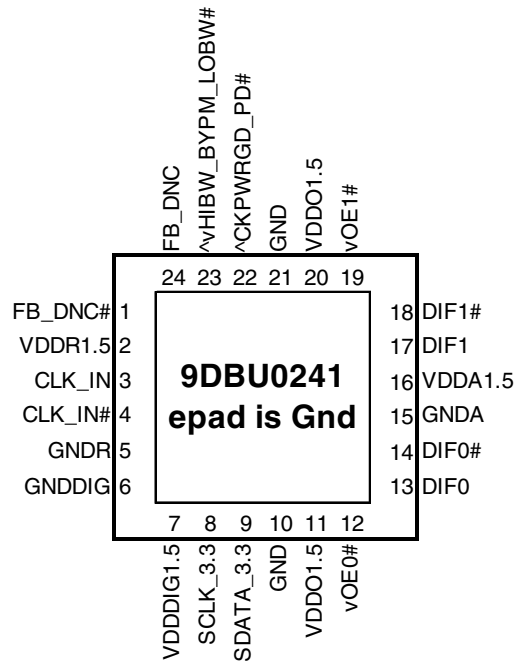

24-pin VFQFPN, 4x4 mm, 0.5mm pitch

^ prefix indicates internal 120KOhm pull up resistor

^v prefix indicates internal 120KOhm pull up AND pull down resistor (biased to VDD/2)

v prefix indicates internal 120KOhm pull down resistor

SMBus Address Selection Table

| Address | + Read/Write bit |
|---------|------------------|
| 1101101 | x |

Power Management Table

| CKPWRGD_PD# | CLK_IN | SMBus OEx bit | OEx# Pin | DIFx | | PLL |
|-------------|---------|---------------|----------|----------|-----------|-----------------|
| | | | | True O/P | Comp. O/P | |
| 0 | X | X | X | Low | Low | Off |
| 1 | Running | 0 | X | Low | Low | On ¹ |
| 1 | Running | 1 | 0 | Running | Running | On ¹ |
| 1 | Running | 1 | 1 | Low | Low | On ¹ |

1. If Bypass mode is selected, the PLL will be off, and outputs will be running.

Power Connections

| Pin Number | | Description |
|------------|-------|-----------------------|
| VDD | GND | |
| 2 | 5 | Input receiver analog |
| 7 | 6 | Digital Power |
| 11,20 | 10,21 | DIF outputs |
| 16 | 15 | PLL Analog |

Note: epad on this device is not electrically connected to the die. It should be connected to ground for best thermal performance.

PLL Operating Mode

| HiBW_ByPM_LoBW# | MODE | Byte1 [7:6] Readback | Byte1 [4:3] Control |
|-----------------|-----------|----------------------|---------------------|
| 0 | PLL Lo BW | 00 | 00 |
| M | Bypass | 01 | 01 |
| 1 | PLL Hi BW | 11 | 11 |

Pin Descriptions

| Pin# | Pin Name | Pin Type | Description |
|------|-------------------|------------|---|
| 1 | FB_DNC# | DNC | Complement clock of differential feedback. The feedback output and feedback input are connected internally on this pin. Do not connect anything to this pin. |
| 2 | VDDR1.5 | PWR | 1.5V power for differential input clock (receiver). This VDD should be treated as an Analog power rail and filtered appropriately. |
| 3 | CLK_IN | IN | True Input for differential reference clock. |
| 4 | CLK_IN# | IN | Complementary Input for differential reference clock. |
| 5 | GNDR | GND | Analog Ground pin for the differential input (receiver) |
| 6 | GNDDIG | GND | Ground pin for digital circuitry |
| 7 | VDDDIG1.5 | PWR | 1.5V digital power (dirty power) |
| 8 | SCLK_3.3 | IN | Clock pin of SMBus circuitry, 3.3V tolerant. |
| 9 | SDATA_3.3 | I/O | Data pin for SMBus circuitry, 3.3V tolerant. |
| 10 | GND | GND | Ground pin. |
| 11 | VDDO1.5 | PWR | Power supply for outputs, nominally 1.5V. |
| 12 | vOE0# | IN | Active low input for enabling DIF pair 0. This pin has an internal pull-down. 1 =disable outputs, 0 = enable outputs |
| 13 | DIF0 | OUT | Differential true clock output |
| 14 | DIF0# | OUT | Differential Complementary clock output |
| 15 | GNDA | GND | Ground pin for the PLL core. |
| 16 | VDDA1.5 | PWR | 1.5V power for the PLL core. |
| 17 | DIF1 | OUT | Differential true clock output |
| 18 | DIF1# | OUT | Differential Complementary clock output |
| 19 | vOE1# | IN | Active low input for enabling DIF pair 1. This pin has an internal pull-down. 1 =disable outputs, 0 = enable outputs |
| 20 | VDDO1.5 | PWR | Power supply for outputs, nominally 1.5V. |
| 21 | GND | GND | Ground pin. |
| 22 | ^CKPWRGD_PD# | IN | Input notifies device to sample latched inputs and start up on first high assertion. Low enters Power Down Mode, subsequent high assertions exit Power Down Mode. This pin has internal pull-up resistor. |
| 23 | ^vHIBW_BYPM_LOBW# | LATCHED IN | Trilevel input to select High BW, Bypass or Low BW mode. See PLL Operating Mode Table for Details. |
| 24 | FB_DNC | DNC | True clock of differential feedback. The feedback output and feedback input are connected internally on this pin. Do not connect anything to this pin. |
| 25 | ePad | GND | Connect ePad to ground. |

NOTE: DNC indicates Do Not Connect anything to this pin.

Test Loads

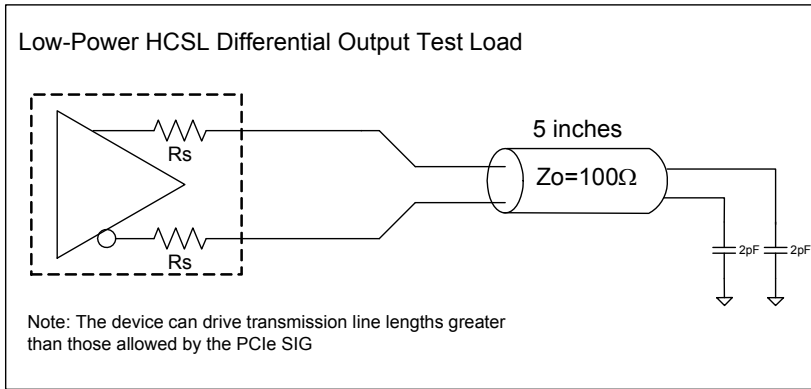

Driving LVDS

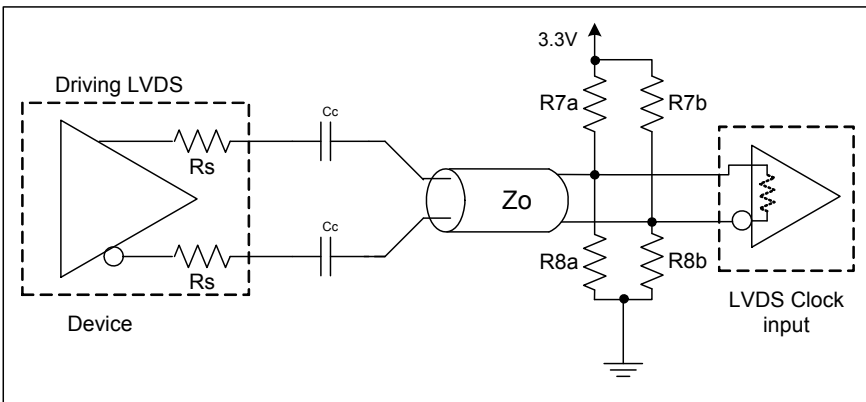

Driving LVDS inputs

| Component | Value | | Note |
|-----------|--------------------------|------------------------------------|------|
| | Receiver has termination | Receiver does not have termination | |
| R7a, R7b | 10K ohm | 140 ohm | |
| R8a, R8b | 5.6K ohm | 75 ohm | |
| Cc | 0.1 uF | 0.1 uF | |
| Vcm | 1.2 volts | 1.2 volts | |

Absolute Maximum Ratings

Stresses above the ratings listed below can cause permanent damage to the 9DBU0241. These ratings, which are standard values for IDT commercially rated parts, are stress ratings only. Functional operation of the device at these or any other conditions above those indicated in the operational sections of the specifications is not implied. Exposure to absolute maximum rating conditions for extended periods can affect product reliability. Electrical parameters are guaranteed only over the recommended operating temperature range.

| PARAMETER | SYMBOL | CONDITIONS | MIN | TYP | MAX | UNITS | NOTES |
|---------------------------|--------------------|---------------------------|------|-----|----------------------|-------|-------|
| Supply Voltage | VDDx | | -0.5 | | 2 | V | 1,2 |
| Input Voltage | V _{IN} | | -0.5 | | V _{DD} +0.5 | V | 1,3 |
| Input High Voltage, SMBus | V _{IHSMB} | SMBus clock and data pins | | | 3.3 | V | 1 |
| Storage Temperature | T _s | | -65 | | 150 | °C | 1 |
| Junction Temperature | T _j | | | | 125 | °C | 1 |
| Input ESD protection | ESD prot | Human Body Model | 2000 | | | V | 1 |

¹Guaranteed by design and characterization, not 100% tested in production.

²Operation under these conditions is neither implied nor guaranteed.

³Not to exceed 2.0V.

Electrical Characteristics–Clock Input Parameters

T_A = T_{AMB}, Supply Voltages per normal operation conditions, See Test Loads for Loading Conditions

| PARAMETER | SYMBOL | CONDITIONS | MIN | TYP | MAX | UNITS | NOTES |
|------------------------------------|--------------------|---|-----|-----|------|-------|-------|
| Input Common Mode Voltage - DIF_IN | V _{COM} | Common Mode Input Voltage | 200 | | 725 | mV | 1 |
| Input Swing - DIF_IN | V _{SWING} | Differential value | 300 | | 1450 | mV | 1 |
| Input Slew Rate - DIF_IN | dv/dt | Measured differentially | 0.4 | | 8 | V/ns | 1,2 |
| Input Leakage Current | I _{IN} | V _{IN} = V _{DD} , V _{IN} = GND | -5 | | 5 | uA | |
| Input Duty Cycle | d _{tin} | Measurement from differential waveform | 45 | 50 | 55 | % | 1 |
| Input Jitter - Cycle to Cycle | J _{DIFIn} | Differential Measurement | 0 | | 150 | ps | 1 |

¹ Guaranteed by design and characterization, not 100% tested in production.

² Slew rate measured through +/-75mV window centered around differential zero

Electrical Characteristics–Input/Supply/Common Parameters–Normal Operating Conditions

TA = T_{AMB}; Supply Voltages per normal operation conditions, See Test Loads for Loading Conditions

| PARAMETER | SYMBOL | CONDITIONS | MIN | TYP | MAX | UNITS | NOTES |
|--|------------------------|---|----------------------|--------|-----------------------|--------|-------|
| Supply Voltage | VDDx | Supply voltage for core and analog | 1.425 | 1.5 | 1.575 | V | |
| Ambient Operating Temperature | T _{AMB} | Commercial range | 0 | 25 | 70 | °C | 1 |
| | | Industrial range | -40 | 25 | 85 | °C | 1 |
| Input High Voltage | V _{IH} | Single-ended inputs, except SMBus | 0.75 V _{DD} | | V _{DD} + 0.3 | V | |
| Input Mid Voltage | V _{IM} | Single-ended tri-level inputs ('_tri' suffix) | 0.4 V _{DD} | | 0.6 V _{DD} | V | |
| Input Low Voltage | V _{IL} | Single-ended inputs, except SMBus | -0.3 | | 0.25 V _{DD} | V | |
| Input Current | I _{IN} | Single-ended inputs, V _{IN} = GND, V _{IN} = VDD | -5 | | 5 | uA | |
| | I _{INP} | Single-ended inputs V _{IN} = 0 V; Inputs with internal pull-up resistors V _{IN} = VDD; Inputs with internal pull-down resistors | -200 | | 200 | uA | |
| Input Frequency | F _{ibyp} | Bypass mode | 1 | | 167 | MHz | 2 |
| | F _{ipll} | 100MHz PLL mode | 20 | 100.00 | 110 | MHz | 2 |
| Pin Inductance | L _{pin} | | | | 7 | nH | 1 |
| Capacitance | C _{IN} | Logic Inputs, except DIF_IN | 1.5 | | 5 | pF | 1 |
| | C _{INDIF_IN} | DIF_IN differential clock inputs | 1.5 | | 2.7 | pF | 1,5 |
| | C _{OUT} | Output pin capacitance | | | 6 | pF | 1 |
| Clk Stabilization | T _{STAB} | From V _{DD} Power-Up and after input clock stabilization or de-assertion of PD# to 1st clock | | | 1 | ms | 1,2 |
| Input SS Modulation Frequency PCIe | f _{MODINPCIe} | Allowable Frequency for PCIe Applications (Triangular Modulation) | 30 | | 33 | kHz | |
| Input SS Modulation Frequency non-PCIe | f _{MODIN} | Allowable Frequency for non-PCIe Applications (Triangular Modulation) | 0 | | 66 | kHz | |
| OE# Latency | t _{LATOE#} | DIF start after OE# assertion DIF stop after OE# deassertion | 1 | | 3 | clocks | 1,3 |
| Tdrive_PD# | t _{DRVDPD} | DIF output enable after PD# de-assertion | | | 300 | us | 1,3 |
| Tfall | t _F | Fall time of single-ended control inputs | | | 5 | ns | 2 |
| Trise | t _R | Rise time of single-ended control inputs | | | 5 | ns | 2 |
| SMBus Input Low Voltage | V _{ILSMB} | | | | 0.6 | V | |
| SMBus Input High Voltage | V _{IHSMB} | V _{DD} SMB = 3.3V, see note 4 for V _{DD} SMB < 3.3V | 2.1 | | 3.3 | V | 4 |
| SMBus Output Low Voltage | V _{OLSMB} | @ I _{PULLUP} | | | 0.4 | V | |
| SMBus Sink Current | I _{PULLUP} | @ V _{OL} | 4 | | | mA | |
| Nominal Bus Voltage | V _{DD} SMB | Bus Voltage | 1.425 | | 3.3 | V | |
| SCLK/SDATA Rise Time | t _{RSMB} | (Max VIL - 0.15) to (Min VIH + 0.15) | | | 1000 | ns | 1 |
| SCLK/SDATA Fall Time | t _{FSMB} | (Min VIH + 0.15) to (Max VIL - 0.15) | | | 300 | ns | 1 |
| SMBus Operating Frequency | f _{MAXSMB} | Maximum SMBus operating frequency | | | 400 | kHz | 6 |

¹Guaranteed by design and characterization, not 100% tested in production.

²Control input must be monotonic from 20% to 80% of input swing.

³Time from deassertion until outputs are >200 mV

⁴ For V_{DD}SMB < 3.3V, V_{IHSMB} >= 0.8xV_{DD}SMB

⁵DIF_IN input

⁶The differential input clock must be running for the SMBus to be active

Electrical Characteristics–DIF Low-Power HCSL Outputs

TA = T_{AMB}; Supply Voltages per normal operation conditions, See Test Loads for Loading Conditions

| PARAMETER | SYMBOL | CONDITIONS | MIN | TYP | MAX | UNITS | NOTES |
|------------------------|------------------------|---|------|------|------|-------|-------|
| Slew rate | dV/dt | Scope averaging on, fast setting (100MHz) | 1 | 2.4 | 3.5 | V/ns | 1,2,3 |
| | dV/dt | Scope averaging on, slow setting (100MHz) | 0.7 | 1.7 | 2.5 | V/ns | 1,2,3 |
| Slew rate matching | ΔV/dt | Slew rate matching, Scope averaging on | | 9 | 20 | % | 1,2,4 |
| Voltage High | V _{HIGH} | Statistical measurement on single-ended signal using oscilloscope math function. (Scope averaging on) | 630 | 750 | 850 | mV | 7 |
| Voltage Low | V _{LOW} | | -150 | 26 | 150 | | 7 |
| Max Voltage | V _{max} | Measurement on single ended signal using absolute value. (Scope averaging off) | | 763 | 1150 | mV | 7 |
| Min Voltage | V _{min} | | -300 | 22 | | | 7 |
| Vswing | Vswing | Scope averaging off | 300 | 1448 | | mV | 1,2 |
| Crossing Voltage (abs) | V _{cross_abs} | Scope averaging off | 250 | 390 | 550 | mV | 1,5 |
| Crossing Voltage (var) | Δ-V _{cross} | Scope averaging off | | 11 | 140 | mV | 1,6 |

¹Guaranteed by design and characterization, not 100% tested in production.

² Measured from differential waveform

³ Slew rate is measured through the Vswing voltage range centered around differential 0V. This results in a +/-150mV window around differential 0V.

⁴ Matching applies to rising edge rate for Clock and falling edge rate for Clock#. It is measured using a +/-75mV window centered on the average cross point where Clock rising meets Clock# falling. The median cross point is used to calculate the voltage thresholds the oscilloscope is to use for the edge rate calculations.

⁵ V_{cross} is defined as voltage where Clock = Clock# measured on a component test board and only applies to the differential rising edge (i.e. Clock rising and Clock# falling).

⁶ The total variation of all V_{cross} measurements in any particular system. Note that this is a subset of V_{cross_min/max} (V_{cross} absolute) allowed. The intent is to limit V_{cross} induced modulation by setting Δ-V_{cross} to be smaller than V_{cross} absolute.

⁷ At default SMBus settings.

Electrical Characteristics–Current Consumption

TA = T_{AMB}; Supply Voltages per normal operation conditions, See Test Loads for Loading Conditions

| PARAMETER | SYMBOL | CONDITIONS | MIN | TYP | MAX | UNITS | NOTES |
|--------------------------|----------------------|--|-----|-------|------|-------|-------|
| Operating Supply Current | I _{DDR} | VDDR @100MHz | | 3 | 6 | mA | 1 |
| | I _{DDDIG} | VDDIG, All outputs @100MHz | | 0.125 | 0.25 | mA | 1 |
| | I _{DDAO} | VDDA+VDDO, PLL Mode, All outputs @100MHz | | 13 | 17 | mA | 1 |
| Powerdown Current | I _{DDRPD} | VDDR, CKPWRGD_PD# = 0 | | 0.1 | 0.3 | mA | 1,2,3 |
| | I _{DDDIGPD} | VDDDIG, CKPWRGD_PD# = 0 | | 0.1 | 0.2 | mA | 1,2 |
| | I _{DDAOPD} | VDDA+VDDO, CKPWRGD_PD# = 0 | | 0.7 | 1 | mA | 1,2 |

¹ Guaranteed by design and characterization, not 100% tested in production.

² Input clock stopped.

³ In bypass mode, the PLL is off and IDDAO is ~50% of this value.

Electrical Characteristics–Output Duty Cycle, Jitter, Skew and PLL Characteristics

TA = T_{AMB}; Supply Voltages per normal operation conditions, See Test Loads for Loading Conditions

| PARAMETER | SYMBOL | CONDITIONS | MIN | TYP | MAX | UNITS | NOTES |
|------------------------|----------------------|--|------|------|------|-------|-------|
| PLL Bandwidth | BW | -3dB point in High BW Mode (100MHz) | 2.3 | 3.6 | 4.7 | MHz | 1,5 |
| | | -3dB point in Low BW Mode (100MHz) | 1 | 1.6 | 2.5 | MHz | 1,5 |
| PLL Jitter Peaking | t _{JPEAK} | Peak Pass band Gain (100MHz) | | 1.3 | 2.5 | dB | 1 |
| Duty Cycle | t _{DC} | Measured differentially, PLL Mode | 45 | 50 | 55 | % | 1 |
| Duty Cycle Distortion | t _{DCD} | Measured differentially, Bypass Mode @100MHz | -1.5 | -1.1 | 0 | % | 1,3 |
| Skew, Input to Output | t _{pdBYP} | Bypass Mode, V _T = 50% | 3400 | 4301 | 5200 | ps | 1 |
| | t _{pdPLL} | PLL Mode V _T = 50% | 0 | 50 | 150 | ps | 1,4 |
| Skew, Output to Output | t _{sk3} | V _T = 50% | | 37 | 50 | ps | 1,4 |
| Jitter, Cycle to cycle | t _{jcy-cyc} | PLL mode | | 24 | 50 | ps | 1,2 |
| | | Additive Jitter in Bypass Mode | | 0.1 | 5 | ps | 1,2 |

¹ Guaranteed by design and characterization, not 100% tested in production.

² Measured from differential waveform

³ Duty cycle distortion is the difference in duty cycle between the output and the input clock when the device is operated in bypass mode.

⁴ All outputs at default slew rate

⁵ The MIN/TYP/MAX values of each BW setting track each other, i.e., Low BW MAX will never occur with Hi BW MIN.

Electrical Characteristics–Phase Jitter Parameters

TA = T_{AMB}; Supply Voltages per normal operation conditions, See Test Loads for Loading Conditions

| PARAMETER | SYMBOL | CONDITIONS | MIN | TYP | MAX | INDUSTRY LIMIT | UNITS | Notes |
|------------------------------------|---|--|-----|-----|-----|----------------|----------|-----------|
| Phase Jitter, PLL Mode | t _{jphPCleG1} | PCIe Gen 1 | | 30 | 58 | 86 | ps (p-p) | 1,2,3,5 |
| | t _{jphPCleG2} | PCIe Gen 2 Lo Band 10kHz < f < 1.5MHz | | 0.9 | 1.4 | 3 | ps (rms) | 1,2,3,5 |
| | | PCIe Gen 2 High Band 1.5MHz < f < Nyquist (50MHz) | | 2.1 | 2.6 | 3.1 | ps (rms) | 1,2,3,5 |
| | t _{jphPCleG3Com} | PCIe Gen 3 Common Clock Architecture (PLL BW of 2-4 or 2-5MHz, CDR = 10MHz) | | 0.5 | 0.6 | 1 | ps (rms) | 1,2,3,5 |
| | t _{jphPCleG3SRns} | PCIe Gen 3 Separate Reference No Spread (SRns) (PLL BW of 2-4 or 2-5MHz, CDR = 10MHz) | | 0.5 | 0.6 | 0.7 | ps (rms) | 1,2,3,5 |
| Additive Phase Jitter, Bypass Mode | t _{jphPCleG1} | PCIe Gen 1 | | 0.1 | 5 | N/A | ps (p-p) | 1,2,3,5 |
| | t _{jphPCleG2} | PCIe Gen 2 Lo Band 10kHz < f < 1.5MHz | | 0.1 | 0.5 | N/A | ps (rms) | 1,2,3,4,5 |
| | | PCIe Gen 2 High Band 1.5MHz < f < Nyquist (50MHz) | | 0.1 | 0.3 | N/A | ps (rms) | 1,2,3,4 |
| | t _{jphPCleG3} | PCIe Gen 3 (PLL BW of 2-4 or 2-5MHz, CDR = 10MHz) | | 0.2 | 0.3 | N/A | ps (rms) | 1,2,3,4 |
| | t _{jph125M0} | 125MHz, 1.5MHz to 10MHz, -20dB/decade rollover < 1.5MHz, -40db/decade rolloff > 10MHz | | 200 | 300 | N/A | fs (rms) | 1,6 |
| t _{jph125M1} | 125MHz, 12KHz to 20MHz, -20dB/decade rollover < 1.5MHz, -40db/decade rolloff > 10MHz | | 313 | 350 | N/A | fs (rms) | 1,6 | |

¹ Guaranteed by design and characterization, not 100% tested in production.

² See <http://www.pcisig.com> for complete specs

³ Sample size of at least 100K cycles. This figures extrapolates to 108ps pk-pk @ 1M cycles for a BER of 1-12.

⁴ For RMS figures, additive jitter is calculated by solving the following equation: Additive jitter = SQRT[(total jitter)² - (input jitter)²]

⁵ Driven by 9FGU0831 or equivalent

⁶ Rohde&Schartz SMA100

Additive Phase Jitter Plot: 125M (12kHz to 20MHz)



General SMBus Serial Interface Information

How to Write

- Controller (host) sends a start bit
- Controller (host) sends the write address
- IDT clock will **acknowledge**
- Controller (host) sends the beginning byte location = N
- IDT clock will **acknowledge**
- Controller (host) sends the byte count = X
- IDT clock will **acknowledge**
- Controller (host) starts sending Byte N through Byte N+X-1
- IDT clock will **acknowledge** each byte **one at a time**
- Controller (host) sends a Stop bit

| Index Block Write Operation | | |
|-----------------------------|-----------|----------------------|
| Controller (Host) | | IDT (Slave/Receiver) |
| T | starT bit | |
| Slave Address | | |
| WR | WRite | |
| Beginning Byte = N | | ACK |
| Data Byte Count = X | | ACK |
| Beginning Byte N | | ACK |
| O | | X Byte |
| O | | |
| O | | |
| Byte N + X - 1 | | ACK |
| P | stoP bit | |

How to Read

- Controller (host) will send a start bit
- Controller (host) sends the write address
- IDT clock will **acknowledge**
- Controller (host) sends the beginning byte location = N
- IDT clock will **acknowledge**
- Controller (host) will send a separate start bit
- Controller (host) sends the read address
- IDT clock will **acknowledge**
- IDT clock will send the data byte count = X
- IDT clock sends Byte N+X-1
- IDT clock sends **Byte 0 through Byte X (if X_(H) was written to Byte 8)**
- Controller (host) will need to acknowledge each byte
- Controller (host) will send a not acknowledge bit
- Controller (host) will send a stop bit

| Index Block Read Operation | | |
|----------------------------|-----------------|----------------------|
| Controller (Host) | | IDT (Slave/Receiver) |
| T | starT bit | |
| Slave Address | | |
| WR | WRite | |
| Beginning Byte = N | | ACK |
| Data Byte Count = X | | ACK |
| RT | Repeat starT | |
| Slave Address | | |
| RD | ReaD | |
| Beginning Byte N | | ACK |
| Data Byte Count=X | | ACK |
| Beginning Byte N | | |
| Byte N + X - 1 | | |
| O | | X Byte |
| O | | |
| O | | |
| O | | |
| Byte N + X - 1 | | |
| N | Not acknowledge | |
| P | stoP bit | |

Note: SMBus Address is Latched on SADR pin.

SMBus Table: Output Enable Register ¹

| Byte 0 | Name | Control Function | Type | 0 | 1 | Default |
|--------|---------|------------------|------|---------|---------|---------|
| Bit 7 | | Reserved | | | | 1 |
| Bit 6 | | Reserved | | | | 1 |
| Bit 5 | DIF OE1 | Output Enable | RW | Low/Low | Enabled | 1 |
| Bit 4 | | Reserved | | | | 1 |
| Bit 3 | DIF OE0 | Output Enable | RW | Low/Low | Enabled | 1 |
| Bit 2 | | Reserved | | | | 1 |
| Bit 1 | | Reserved | | | | 1 |
| Bit 0 | | Reserved | | | | 1 |

1. A low on these bits will override the OE# pin and force the differential output Low/Low

SMBus Table: PLL Operating Mode and Output Amplitude Control Register

| Byte 1 | Name | Control Function | Type | 0 | 1 | Default |
|--------|-----------------|-------------------------------|-----------------|--------------------------------|--------------------------------|---------|
| Bit 7 | PLLMODERB1 | PLL Mode Readback Bit 1 | R | See PLL Operating Mode Table | | Latch |
| Bit 6 | PLLMODERB0 | PLL Mode Readback Bit 0 | R | | | Latch |
| Bit 5 | PLLMODE_SWCNTRL | Enable SW control of PLL Mode | RW | Values in B1[7:6] set PLL Mode | Values in B1[4:3] set PLL Mode | 0 |
| Bit 4 | PLLMODE1 | PLL Mode Control Bit 1 | RW ¹ | See PLL Operating Mode Table | | 0 |
| Bit 3 | PLLMODE0 | PLL Mode Control Bit 0 | RW ¹ | | | 0 |
| Bit 2 | | Reserved | | | | 1 |
| Bit 1 | AMPLITUDE 1 | Controls Output Amplitude | RW | 00 = 0.55V | 01 = 0.65V | 1 |
| Bit 0 | AMPLITUDE 0 | | RW | 10 = 0.75V | 11 = 0.85V | 0 |

1. B1[5] must be set to a 1 for these bits to have any effect on the part.

SMBus Table: DIF Slew Rate Control Register

| Byte 2 | Name | Control Function | Type | 0 | 1 | Default |
|--------|------------------|---------------------|------|--------------|--------------|---------|
| Bit 7 | | Reserved | | | | 1 |
| Bit 6 | | Reserved | | | | 1 |
| Bit 5 | SLEWRATESEL DIF1 | Slew Rate Selection | RW | Slow Setting | Fast Setting | 1 |
| Bit 4 | | Reserved | | | | 1 |
| Bit 3 | SLEWRATESEL DIF0 | Slew Rate Selection | RW | Slow Setting | Fast Setting | 1 |
| Bit 2 | | Reserved | | | | 1 |
| Bit 1 | | Reserved | | | | 1 |
| Bit 0 | | Reserved | | | | 1 |

SMBus Table: FB Slew Rate Control Register

| Byte 3 | Name | Control Function | Type | 0 | 1 | Default |
|--------|----------------|------------------------|------|--------------|--------------|---------|
| Bit 7 | | Reserved | | | | 1 |
| Bit 6 | | Reserved | | | | 1 |
| Bit 5 | | Reserved | | | | 0 |
| Bit 4 | | Reserved | | | | 0 |
| Bit 3 | | Reserved | | | | 0 |
| Bit 2 | | Reserved | | | | 1 |
| Bit 1 | | Reserved | | | | 1 |
| Bit 0 | SLEWRATESEL FB | Adjust Slew Rate of FB | RW | Slow Setting | Fast Setting | 1 |

Byte 4 is Reserved and reads back 'hFF'

SMBus Table: Revision and Vendor ID Register

| Byte 5 | Name | Control Function | Type | 0 | 1 | Default |
|--------|------|------------------|------|--------------|---|---------|
| Bit 7 | RID3 | Revision ID | R | A rev = 0000 | | 0 |
| Bit 6 | RID2 | | R | | | 0 |
| Bit 5 | RID1 | | R | | | 0 |
| Bit 4 | RID0 | | R | | | 0 |
| Bit 3 | VID3 | VENDOR ID | R | 0001 = IDT | | 0 |
| Bit 2 | VID2 | | R | | | 0 |
| Bit 1 | VID1 | | R | | | 0 |
| Bit 0 | VID0 | | R | | | 1 |

SMBus Table: Device Type/Device ID

| Byte 6 | Name | Control Function | Type | 0 | 1 | Default |
|--------|--------------|------------------|------|--|---|---------|
| Bit 7 | Device Type1 | Device Type | R | 00 = FGx, 01 = DBx ZDB/FOB, 10 = DMx, 11= DBx FOB | | 0 |
| Bit 6 | Device Type0 | | R | | | 1 |
| Bit 5 | Device ID5 | Device ID | R | 000100 binary or 02 hex | | 0 |
| Bit 4 | Device ID4 | | R | | | 0 |
| Bit 3 | Device ID3 | | R | | | 0 |
| Bit 2 | Device ID2 | | R | | | 0 |
| Bit 1 | Device ID1 | | R | | | 1 |
| Bit 0 | Device ID0 | | R | | | 0 |

SMBus Table: Byte Count Register

| Byte 7 | Name | Control Function | Type | 0 | 1 | Default |
|--------|------|------------------------|------|---|---|---------|
| Bit 7 | | Reserved | | | | 0 |
| Bit 6 | | Reserved | | | | 0 |
| Bit 5 | | Reserved | | | | 0 |
| Bit 4 | BC4 | Byte Count Programming | RW | Writing to this register will configure how many bytes will be read back, default is = 8 bytes. | | 0 |
| Bit 3 | BC3 | | RW | | | 1 |
| Bit 2 | BC2 | | RW | | | 0 |
| Bit 1 | BC1 | | RW | | | 0 |
| Bit 0 | BC0 | | RW | | | 0 |

Marking Diagrams

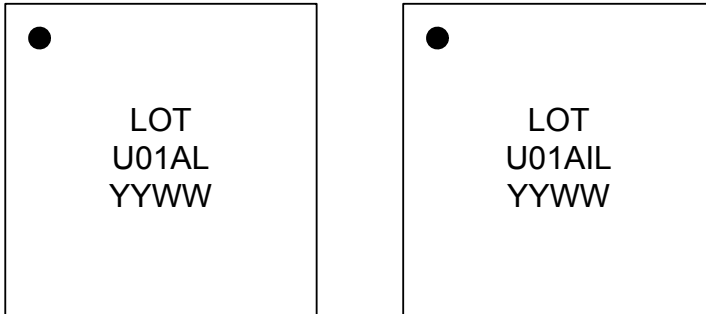

Notes:

1. "LOT" is the lot sequence number.
2. YYWW is the last two digits of the year and week that the part was assembled.
3. Line 2: truncated part number
4. "L" denotes RoHS compliant package.
5. "I" denotes industrial temperature range device.

Thermal Characteristics

| PARAMETER | SYMBOL | CONDITIONS | PKG | TYP VALUE | UNITS | NOTES |
|--------------------|----------------|---------------------------------|----------------|-----------|-----------------------------|-------|
| Thermal Resistance | Θ_{JC} | Junction to Case | NLG20 NLG24 | 62 | $^{\circ}\text{C}/\text{W}$ | 1 |
| | Θ_{Jb} | Junction to Base | | 5.4 | $^{\circ}\text{C}/\text{W}$ | 1 |
| | Θ_{JA0} | Junction to Air, still air | | 50 | $^{\circ}\text{C}/\text{W}$ | 1 |
| | Θ_{JA1} | Junction to Air, 1 m/s air flow | | 43 | $^{\circ}\text{C}/\text{W}$ | 1 |
| | Θ_{JA3} | Junction to Air, 3 m/s air flow | | 39 | $^{\circ}\text{C}/\text{W}$ | 1 |
| | Θ_{JA5} | Junction to Air, 5 m/s air flow | | 38 | $^{\circ}\text{C}/\text{W}$ | 1 |

¹ePad soldered to board

Package Outline and Package Dimensions (NLG24)

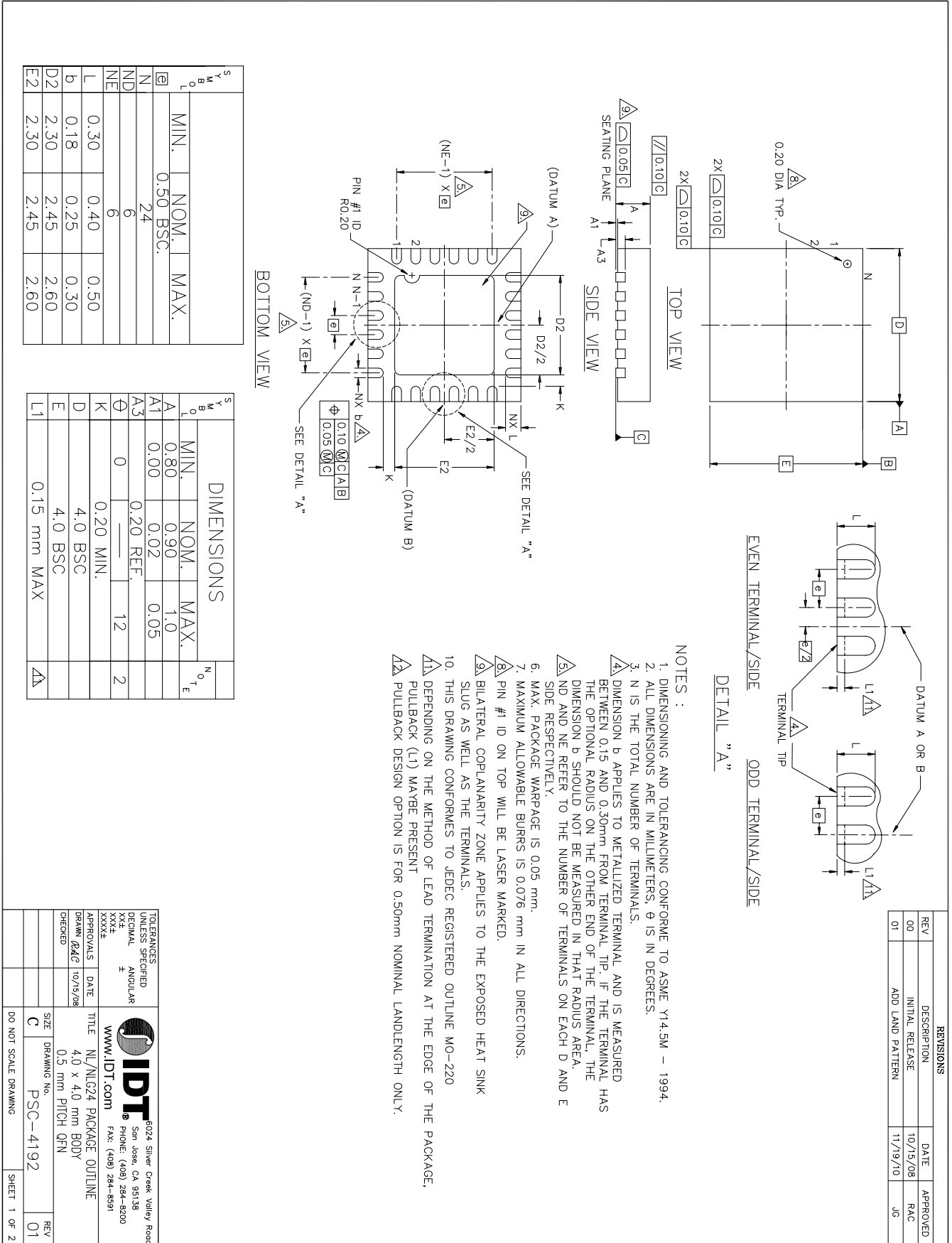

| S^M | M | B | L | N | ND | NE | L | b | $D2$ | $E2$ |
|----------|------|-----------|------|-----|------|------|------|------|------|------|
| | MIN. | NOM. | MAX. | | | | | | | |
| θ | | 0.50 BSC. | | 24 | 6 | 6 | 0.30 | 0.40 | 0.25 | 0.30 |
| N | | | | | | | 0.18 | 0.25 | 2.45 | 2.60 |
| ND | | | | | | | 0.30 | 0.40 | 2.45 | 2.60 |
| NE | | | | | | | 0.30 | 0.40 | 2.45 | 2.60 |
| L | | | | | | | 0.18 | 0.25 | 2.45 | 2.60 |
| b | | | | | | | 0.30 | 0.40 | 2.45 | 2.60 |
| D2 | | | | | | | 0.18 | 0.25 | 2.45 | 2.60 |
| E2 | | | | | | | 0.30 | 0.40 | 2.45 | 2.60 |

| S^M | M | B | L | N | ND | NE | L | b | $D2$ | $E2$ |
|-------|------|-------------|------|-----|------|------|-----|-----|------|------|
| | MIN. | NOM. | MAX. | | | | | | | |
| A | 0.80 | 0.90 | 1.0 | | | | | | | |
| A1 | 0.00 | 0.02 | 0.05 | | | | | | | |
| A3 | 0 | 0.20 REF. | | | | | | | | |
| K | | 0.20 MIN. | | | | | | | | |
| D | | 4.0 BSC | | | | | | | | |
| E | | 4.0 BSC | | | | | | | | |
| L1 | | 0.15 mm MAX | | | | | | | | |

Package Outline and Package Dimensions (NLG24), cont.

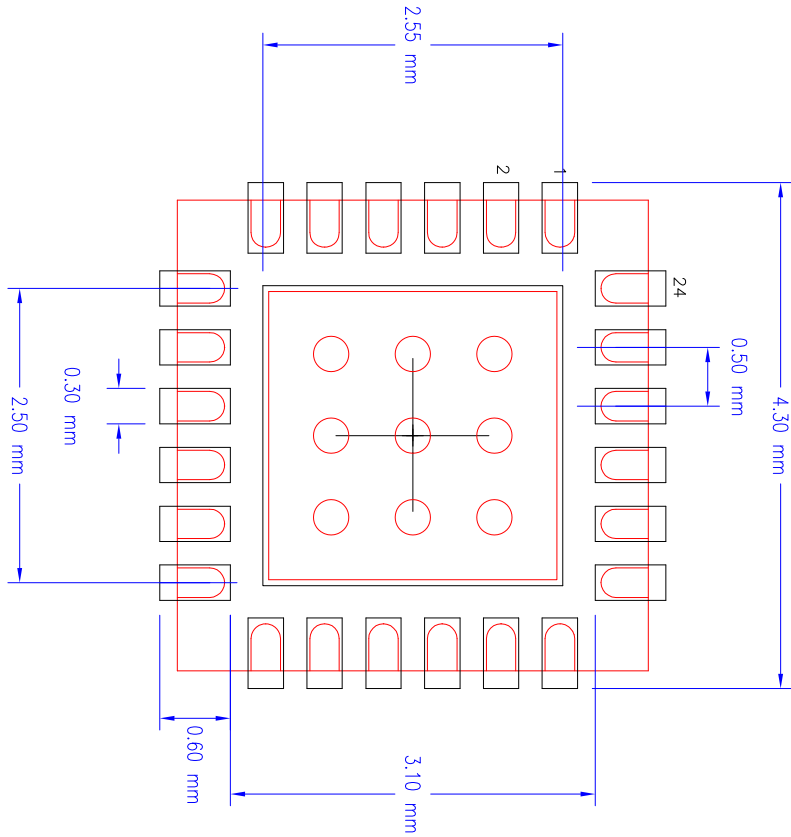

NLG24 RECOMMENDED FOOTPRINT 2.45 mm SQ EPAD

| REVISIONS | | | |
|-----------|------------------|----------|----------|
| REV | DESCRIPTION | DATE | APPROVED |
| 00 | INITIAL RELEASE | 11/19/10 | JG |
| 01 | ADD LAND PATTERN | 11/19/10 | JG |

| | | |
|-----------------------------|-------------|---|
| TOLERANCES UNLESS SPECIFIED | | 8024 Silver Creek Valley Road San Jose, CA 95138 PHONE: (408) 284-8200 FAX: (408) 284-8591 |
| DECIMAL | ANGULAR | |
| XXXX | ± | www.idt.com |
| APPROVALS | DATE | TITLE |
| DRAWN: <i>gb</i> | 11/19/10 | NL/NLG24 PACKAGE OUTLINE |
| CHECKED | | 4.0 x 4.0 mm BODY 0.5 mm PITCH VFOEPN |
| SIZE | DRAWING No. | REV |
| C | PSC-4192 | 01 |
| DO NOT SCALE DRAWING | | SHEET 2 OF 2 |

Ordering Information

| Part / Order Number | Shipping Packaging | Package | Temperature |
|---------------------|--------------------|---------------|---------------|
| 9DBU0241AKLF | Tubes | 24-pin VFQFPN | 0 to +70° C |
| 9DBU0241AKLFT | Tape and Reel | 24-pin VFQFPN | 0 to +70° C |
| 9DBU0241AKILF | Tubes | 24-pin VFQFPN | -40 to +85° C |
| 9DBU0241AKILFT | Tape and Reel | 24-pin VFQFPN | -40 to +85° C |

"LF" suffix to the part number are the Pb-Free configuration and are RoHS compliant.

"A" is the device revision designator (will not correlate with the datasheet revision).

Revision History

| Rev. | Initiator | Issue Date | Description | Page # |
|------|-----------|------------|--|---------|
| A | RDW | 7/14/2014 | <ol style="list-style-type: none"> 1. Updated electrical tables with char data. 2. Added an additive phase jitter plot. 3. Added 12kHz to 20MHz <i>additive</i> phase jitter spec. 4. Updated Amplitude control bit <i>descriptions</i> in Byte 1. | Various |
| B | RDW | 9/19/2014 | Updated SMBus Input High/Low parameters conditions, MAX values, and footnotes. | 6 |
| C | RDW | 4/22/2015 | <ol style="list-style-type: none"> 1. Updated pin out and pin descriptions to show ePad on package connected to ground. 2. Updated front page text to standard format for these devices. Added explicit bullet indicated Spread Spectrum compatibility. 3. Updated Clock Input Parameters table to be consistent with PCIe Vswing parameter. 4. Minor updates to front page text for family consistency. 5. Add note about epad to Power Connections table. | 1-5 |



Corporate Headquarters
6024 Silver Creek Valley Road
San Jose, CA 95138 USA

Sales
1-800-345-7015 or 408-284-8200
Fax: 408-284-2775
www.IDT.com

Tech Support
email: clocks@idt.com

DISCLAIMER Integrated Device Technology, Inc. (IDT) and its subsidiaries reserve the right to modify the products and/or specifications described herein at any time and at IDT's sole discretion. All information in this document, including descriptions of product features and performance, is subject to change without notice. Performance specifications and the operating parameters of the described products are determined in the independent state and are not guaranteed to perform the same way when installed in customer products. The information contained herein is provided without representation or warranty of any kind, whether express or implied, including, but not limited to, the suitability of IDT's products for any particular purpose, an implied warranty of merchantability, or non-infringement of the intellectual property rights of others. This document is presented only as a guide and does not convey any license under intellectual property rights of IDT or any third parties.

IDT's products are not intended for use in applications involving extreme environmental conditions or in life support systems or similar devices where the failure or malfunction of an IDT product can be reasonably expected to significantly affect the health or safety of users. Anyone using an IDT product in such a manner does so at their own risk, absent an express, written agreement by IDT.

Integrated Device Technology, IDT and the IDT logo are registered trademarks of IDT. Product specification subject to change without notice. Other trademarks and service marks used herein, including protected names, logos and designs, are the property of IDT or their respective third party owners.

Copyright ©2015 Integrated Device Technology, Inc.. All rights reserved.

Mouser Electronics

Authorized Distributor

Click to View Pricing, Inventory, Delivery & Lifecycle Information:

[IDT \(Integrated Device Technology\):](#)

[9DBU0241AKLF](#) [9DBU0241AKILF](#) [9DBU0241AKILFT](#) [9DBU0241AKLFT](#)



Компания «ЭлектроПласт» предлагает заключение долгосрочных отношений при поставках импортных электронных компонентов на взаимовыгодных условиях!

Наши преимущества:

- Оперативные поставки широкого спектра электронных компонентов отечественного и импортного производства напрямую от производителей и с крупнейших мировых складов;
- Поставка более 17-ти миллионов наименований электронных компонентов;
- Поставка сложных, дефицитных, либо снятых с производства позиций;
- Оперативные сроки поставки под заказ (от 5 рабочих дней);
- Экспресс доставка в любую точку России;
- Техническая поддержка проекта, помощь в подборе аналогов, поставка прототипов;
- Система менеджмента качества сертифицирована по Международному стандарту ISO 9001;
- Лицензия ФСБ на осуществление работ с использованием сведений, составляющих государственную тайну;
- Поставка специализированных компонентов (Xilinx, Altera, Analog Devices, Intersil, Interpoint, Microsemi, Aeroflex, Peregrine, Syfer, Eurofarad, Texas Instrument, Miteq, Cobham, E2V, MA-COM, Hittite, Mini-Circuits, General Dynamics и др.);

Помимо этого, одним из направлений компании «ЭлектроПласт» является направление «Источники питания». Мы предлагаем Вам помощь Конструкторского отдела:

- Подбор оптимального решения, техническое обоснование при выборе компонента;
- Подбор аналогов;
- Консультации по применению компонента;
- Поставка образцов и прототипов;
- Техническая поддержка проекта;
- Защита от снятия компонента с производства.



Как с нами связаться

Телефон: 8 (812) 309 58 32 (многоканальный)

Факс: 8 (812) 320-02-42

Электронная почта: org@eplast1.ru

Адрес: 198099, г. Санкт-Петербург, ул. Калинина, дом 2, корпус 4, литера А.