

Product Specification

50 GHz High-Power Photodetector

HPDV2120R

PRODUCT FEATURES

- 50 GHz 3 dB bandwidth
- 3 dBm RF output power @ 50 GHz
- 6 dBm RF output power @ 20 GHz
- High Linearity
(>25 dBm OIP3 @ 40 GHz)
- No cooling required

APPLICATIONS

- Microwave Photonics
- Analog Photonic links
- Radio-over-Fiber



The HPDV is a compact module that is based on an advanced waveguide photodetector chip integrated with a Bias-Tee. The HP-PD utilizes a mode-converting tapered waveguide for efficient fiber-to-chip coupling and a 1×4 Multi-Mode Interference (MMI) Coupler. The optical signal is split by the MMI coupler into 4 equal parts and then it is fed into an array of 4 photodiodes which are connected in-parallel. It has a responsivity of 0.52 A/W @ 1550 nm and a high saturation photocurrent of 35 mA @ 20 GHz. The HP-PD is capable of delivering 6 dBm RF output power @ 20 GHz and 3 dBm @ 50 GHz. The device exhibits a high linearity with typical OIP3 values above 20 dBm at a frequency of 40 GHz.

ORDERING INFORMATION

HPDV2120R-VF-zz

R:	R	= internal 50Ω termination
VF:	VF	= V-connector, female
zz:	FC	= FC/PC connector
	FA	= FC/APC connector

I. Block Diagram

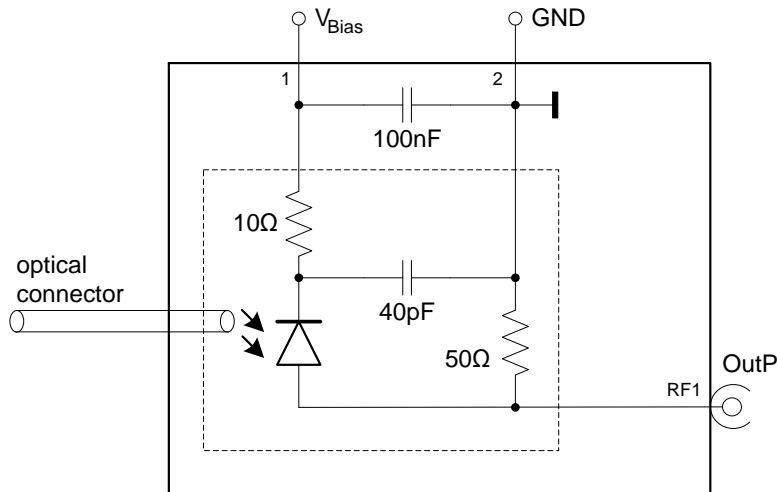

II. Absolute Maximum Ratings

Parameter	Symbol	Condition	Min.	Typ.	Max.	Unit
Storage Temperature	T_{STORAGE}	non condensing	-40		+85	°C
Photodiode Bias Voltage	V_{PD}		0		5.2	V
Maximum Average Optical Input Power	P_{OPT}	continuous wave (CW) or 40 Gb/s NRZ			18.5	dBm
Maximum Peak Optical Input Power	P_{peak}	pulse width ≤ 25 ps or 40 Gb/s RZ			24	dBm
Electrostatic Discharge	V_{ESD}	100pF, 1.5kΩ HBM	-250		+250	V
Fiber Bend Radius	r_{bend}		16			mm



Notice

Stresses greater than those listed under “Absolute Maximum Ratings” may cause permanent damage to the device. This is a stress rating only and functional operation of the device at these or any other conditions above those indicated in the operations section for extended periods of time may affect reliability.

The inherent design of this component causes it to be sensitive to electrostatic discharge (ESD). To prevent ESD-induced damage and/or degradation to equipment, take normal ESD precautions when handling this product.

III. Environmental Conditions

Parameter	Symbol	Condition	Min.	Typ.	Max.	Unit
Relative Humidity Range	RH	non condensing	5		85	%

IV. Operating Conditions

Parameter	Symbol	Condition	Min.	Typ.	Max.	Unit
Case Temperature Range	T_{CASE}		0		+50	°C
Wavelength Range	λ		1520		1570	nm
Average Optical Input Power	P_{OPT}				18	dBm
Photodiode Bias Voltage	V_{PD}		2.8	4.0	5.0	V

V. Electro-Optical Specifications

Parameter	Symbol	Condition	Min.	Typ.	Max.	Unit
DC responsivity	R	optimum polarization	0.4	0.5		A/W
Polarization dependent loss	PDL			0.3	0.7	dB
Optical return loss	ORL		27			dB
3dB cut-off frequency	f_{3dB}		48	54		GHz
Output reflection coefficient	S_{22}	0...15 GHz 15...50 GHz		-15 -3	-10 -1	dB
Output 1dB compression	P_{1dB}	50 GHz, $V_{PD} = 4.0V$		3		dBm
Output 3 rd order intercept point	OIP3	50 GHz, $V_{PD} = 4.0V$		20		dBm
Dark current	I_{dark}			25	200	nA

VI. Typical Performance Curves

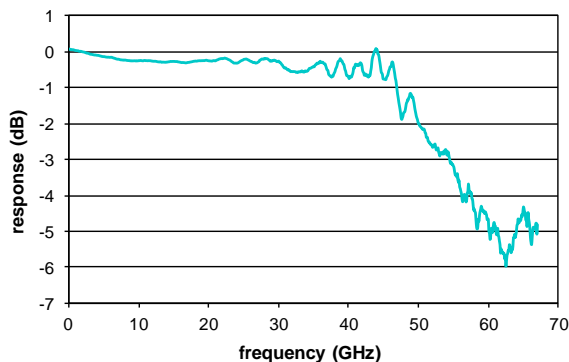

Fig. 1: Frequency response measured with a Lightwave Component Analyzer.

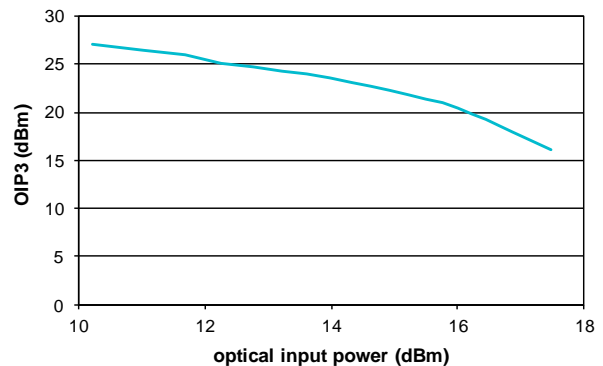

Fig. 2: Output IP3 at a frequency of 20 GHz and at a bias voltage of 4 V.

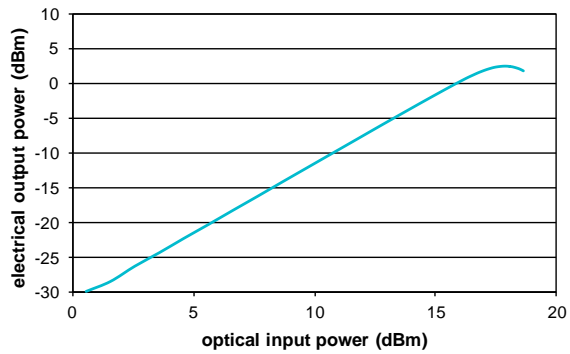

Fig. 3(a): RF output power as a function of the optical input power for a bias voltage of 4 V at a frequency of 50 GHz.

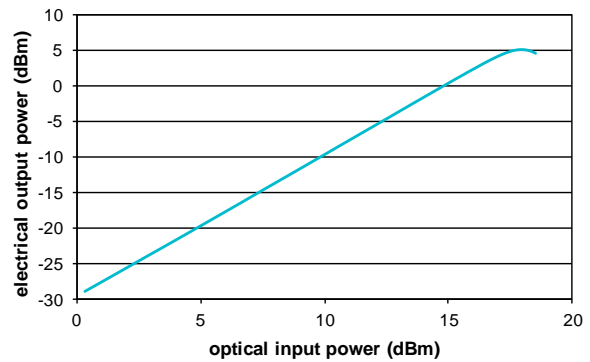

Fig. 3(b): RF output power as a function of the optical input power for a bias voltage of 4 V at a frequency of 20 GHz.

VII. Revision History

Revision	Date	Description
A1	04/09/2014	• Document created.
A2	06/27/2014	• Data and design update according M4

Notes

- Any trademarks used in this document are properties of their respective owners.
- Finisar Corporation reserves the right to make changes without notice.

For More Information

Finisar Corporation
 1389 Moffett Park Drive
 Sunnyvale, CA 94089-1133
 Tel. 1-408-548-1000
 Fax 1-408-541-6138
sales@finisar.com
www.finisar.com



Компания «ЭлектроПласт» предлагает заключение долгосрочных отношений при поставках импортных электронных компонентов на взаимовыгодных условиях!

Наши преимущества:

- Оперативные поставки широкого спектра электронных компонентов отечественного и импортного производства напрямую от производителей и с крупнейших мировых складов;
- Поставка более 17-ти миллионов наименований электронных компонентов;
- Поставка сложных, дефицитных, либо снятых с производства позиций;
- Оперативные сроки поставки под заказ (от 5 рабочих дней);
- Экспресс доставка в любую точку России;
- Техническая поддержка проекта, помощь в подборе аналогов, поставка прототипов;
- Система менеджмента качества сертифицирована по Международному стандарту ISO 9001;
- Лицензия ФСБ на осуществление работ с использованием сведений, составляющих государственную тайну;
- Поставка специализированных компонентов (Xilinx, Altera, Analog Devices, Intersil, Interpoint, Microsemi, Aeroflex, Peregrine, Syfer, Eurofarad, Texas Instrument, Miteq, Cobham, E2V, MA-COM, Hittite, Mini-Circuits, General Dynamics и др.);

Помимо этого, одним из направлений компании «ЭлектроПласт» является направление «Источники питания». Мы предлагаем Вам помощь Конструкторского отдела:

- Подбор оптимального решения, техническое обоснование при выборе компонента;
- Подбор аналогов;
- Консультации по применению компонента;
- Поставка образцов и прототипов;
- Техническая поддержка проекта;
- Защита от снятия компонента с производства.



Как с нами связаться

Телефон: 8 (812) 309 58 32 (многоканальный)

Факс: 8 (812) 320-02-42

Электронная почта: org@eplast1.ru

Адрес: 198099, г. Санкт-Петербург, ул. Калинина, дом 2, корпус 4, литера А.