



**Compact size 2 Form A and 2 Form A 1 Form B 35A power relays for energy management and industrial equipment**

# HE-S RELAYS

**New**



**RoHS compliant**

Protective construction: Flux-resistant type

## FEATURES

**1. High-capacity and long life 35A 277V AC 5×10<sup>4</sup> (long life type)**

**2. Electrical life (resistive load)**

Form A contact	Standard type	Long life type
35A 277V AC	3×10 <sup>4</sup>	5×10 <sup>4</sup>
30A 220V AC	—	1×10 <sup>5</sup>
20A 277V AC	1×10 <sup>5</sup>	2×10 <sup>5</sup>

**3. Compact size and low operating power**

W: 30 × L: 36 × H: 40 mm **W: 1.181 × L: 1.417 × H: 1.575 inch**  
Operating power: 1,880 mW (holding power: 170 mW)

**4. Reduced coil holding voltage contributes to saving energy of equipment**

The coil holding voltage can be reduced up to 30%V of the nominal coil voltage. This equals to operating power of approximately 170 mW, which contributes equipment energy savings.

\* Coil holding voltage is the coil voltage after 100 ms from the applied nominal coil voltage.

**5. Contact gap: 3.2 mm .126 inch (VDE0126 compliant)**

Compliant with European photovoltaic standard VDE0126  
Compliant with EN61810-1 2.5 kV surge breakdown voltage (between contacts)

**6. Insulation distance (initial)**

- Between Form A contact and coil: Min. 11.0 mm .433 inch (Clearance/Creepage)
- Between Form B contact and coil: Min. 3.2 mm .126 inch (Clearance/Creepage)
- Between Form A contact sets: Min. 8.2 mm .323 inch (Clearance/Creepage)
- Between Form A contact and Form B contact: Min. 12.8 mm .504 inch (Clearance/Creepage)

## TYPICAL APPLICATIONS

- Photovoltaic power generation systems (Solar inverter)
- Uninterruptible Power Supplies (UPS)
- Inverter
- Office air conditioner
- Industrial equipment

**7. Contact gap (initial)**

- Form A contact: Min. 3.2 mm .126 inch/each contact
- Form B contact: Min. 0.7 mm .028 inch  
Min. 0.5 mm .020 inch (When Form A contact welded)

**8. Mirror contact mechanisms (Compliant with EN60947-4-1 mirror contact)**

**Detection of main contact welding makes it possible to construct a safety circuit.**

- Designed so that Form A contact and Form B contact will not close at the same time.
- When Form A contact welded, Form B contact gap of at least 0.5 mm .020 inch is maintained.

\* Form B contact, when used to monitor the condition of Form A contact, can be used exclusively as an auxiliary contact.



**ORDERING INFORMATION**

AHES   **9**

Contact arrangement / Operating function  
 3: 2 Form A Single side stable type  
 4: 2 Form A 1 Form B Single side stable type

Contact specifications  
 1: Standard type  
 2: Long life type

Terminals form  
 9: PC board terminal type

Nominal coil voltage (DC)

Part No.	0	1	2	3	5
Nominal coil voltage (V)	6	12	24	48	9

Note: Certified by UL/C-UL and VDE

**TYPES**

Contact arrangement	Nominal coil voltage	Part No.	
		Standard type	Long life type
2 Form A	6V DC	AHES3190	AHES3290
	9V DC	AHES3195	AHES3295
	12V DC	AHES3191	AHES3291
	24V DC	AHES3192	AHES3292
	48V DC	AHES3193	AHES3293
2 Form A 1 Form B	6V DC	AHES4190	AHES4290
	9V DC	AHES4195	AHES4295
	12V DC	AHES4191	AHES4291
	24V DC	AHES4192	AHES4292
	48V DC	AHES4193	AHES4293

Standard packing: Carton: 25 pcs.; Case: 100 pcs.

**RATING**

**1. Coil data**

Nominal coil voltage	Pick-up voltage (at 20°C 68°F) (Initial)	Drop-out voltage (at 20°C 68°F) (Initial)	Nominal operating current [±10%] (at 20°C 68°F)	Coil resistance [±10%] (at 20°C 68°F)	Nominal operating power (at 20°C 68°F)	Max. applied voltage (at 55°C 131°F)
6V DC	75%V or less of nominal voltage	5%V or more of nominal voltage	313mA	19.1Ω	ON: 1,880mW Holding: 170mW*1	110%V of nominal coil voltage 150%V of nominal coil voltage*2
9V DC			209mA	43.1Ω		
12V DC			157mA	76.6Ω		
24V DC			78mA	306.4Ω		
48V DC			39mA	1,225.5Ω		

Notes: \*1. With 30%V coil holding voltage

\*2. With no more than 24 hours per time with non-consecutive voltage application time.

## 2. Specifications

Characteristics	Item		Specifications	
			Standard type	Long life type
Contact	Arrangement		2 Form A, 2 Form A 1 Form B	2 Form A, 2 Form A 1 Form B
	Form A contact	Contact resistance (Initial)	Max. 100mΩ (By voltage drop 6V DC 1A), Max. 3mΩ (By voltage drop 6V DC 20A, Reference value)	
		Contact material	AgSnO <sub>2</sub> type	
	Form B contact*6	Contact resistance (Initial)	Max. 100mΩ (By voltage drop 6V DC 1A)	
Contact material		Au flashed AgNi type		
Rating	Form A contact	Nominal switching capacity (Resistive load)	35A 277V AC	
		Max. switching voltage	480V AC, 110V DC	
		Contact carrying power (Resistive load)	9,695VA	
		Max. switching current	35A	
		Min. switching capacity (Reference value)*1	100mA 5V DC	
	Form B contact*6	Nominal switching capacity (Resistive load)	1A 277V AC, 1A 30V DC	
		Max. switching voltage	277V AC, 30V DC	
		Contact carrying power (Resistive load)	277VA	
		Max. switching current	1A	
	Min. switching capacity (Reference value)*1		10mA 5V DC	
Nominal operating power		1,880mW (after applying min.100ms coil nominal voltage) 170mW (30%V of coil holding voltage)		
Electrical characteristics	Insulation resistance (Initial)		Min. 1,000MΩ (at 500 V DC) Measurement at same location as "Breakdown voltage" section.	
	Short current (A contact, Initial)		Max. 1,000A 1 ms, 3 times (Reference value)	
	Breakdown voltage (Initial)	Between open Form A contacts	2,000 Vrms for 1 min. (Detection current: 10mA)	
		Between Form A contact and coil	5,000 Vrms for 1 min. (Detection current: 10mA)	
		Between Form A contact sets	5,000 Vrms for 1 min. (Detection current: 10mA)	
		Between open Form B contacts	1,000 Vrms for 1 min. (Detection current: 10mA)	
		Between Form B contact and coil	2,000 Vrms for 1 min. (Detection current: 10mA)	
		Between Form A contact and Form B contact	5,000 Vrms for 1 min. (Detection current: 10mA)	
	Surge breakdown voltage*2 (Between contact and coil)		10,000V (Between Form A contact and coil) (Initial) 2,500V (Between Form B contact and coil) (Initial)	
	Coil holding voltage*3		30 to 110%V (Form A contact carrying current: 35A, at -40 to +55°C -40 to +131°F) 30 to 60%V (Form A contact carrying current: 35A, at -40 to +85°C -40 to +185°F)	
Operate time (at 20°C 68°F) (Initial)		Max. 30 ms (at nominal coil voltage, excluding contact bounce time)		
Release time (at 20°C 68°F)*4 (Initial)		Max. 10 ms (at nominal coil voltage, excluding contact bounce time, without diode)		
Mechanical characteristics	Shock resistance	Functional	98 m/s <sup>2</sup> (Half-wave pulse of sine wave: 11 ms; detection time: 10 μs)	
		Destructive	980 m/s <sup>2</sup> (Half-wave pulse of sine wave: 6 ms)	
	Vibration resistance	Functional	10 to 55 Hz at double amplitude of 1.0 mm .039 inch (Detection time: 10 μs)	
		Destructive	10 to 55 Hz at double amplitude of 1.5 mm .059 inch	
Expected life	Mechanical		Min. 5×10 <sup>6</sup> (at 180 times/min.)	
	Electrical (Form A contact)	Resistive load	Min. 3×10 <sup>4</sup> (35A 277V AC) (ON : OFF = 1s : 9s)	Min. 5×10 <sup>4</sup> (35A 277V AC) (ON : OFF = 1s : 9s)
			—	Min. 1×10 <sup>5</sup> (30A 220V AC) (ON : OFF = 1s : 9s)
		Min. 1×10 <sup>5</sup> (20A 277V AC) (ON : OFF = 1s : 9s)	Min. 2×10 <sup>5</sup> (20A 277V AC) (ON : OFF = 1s : 9s)	
	Inductive load	Min. 3×10 <sup>4</sup> (35A 250V AC) (cosφ = 0.8) (ON : OFF = 0.1s : 10s)	Min. 5×10 <sup>4</sup> (35A 250V AC) (cosφ = 0.8) (ON : OFF = 0.1s : 10s)	
Electrical (Form B contact)*6		Resistive load	Min. 1×10 <sup>5</sup> (1A 277V AC) (ON : OFF = 1s : 9s) Min. 1×10 <sup>5</sup> (1A 30V DC) (ON : OFF = 1s : 9s)	
Conditions	Conditions for operation, transport and storage*5		Temperature: -40 to +55°C -40 to +131°F (Coil holding voltage 30 to 110%V) Temperature: -40 to +85°C -40 to +185°F (Coil holding voltage 30 to 60%V or storage) Humidity: 5 to 85% R.H. (Not freezing and condensing at low temperature) Air pressure: 86 to 106 kPa	
Unit weight		Approx. 64 g 2.26 oz		

Notes: \*1. This value can change due to the switching frequency, environmental conditions, and desired reliability level, therefore it is recommended to check this with the actual load.

\*2. Wave is standard shock voltage of ±1.2×50μs according to JEC-212-1981

\*3. Coil holding voltage is the coil voltage after 100 ms from the applied nominal coil voltage.

\*4. Release time will lengthen if a diode, etc., is connected in parallel to the coil. Be sure to verify operation under actual conditions.

\*5. The upper operation ambient temperature limit is the maximum temperature that can satisfy the coil temperature rise value. Refer to Usage, transport and storage conditions in NOTES.

\*6. Regarding Form B contact, only the 2 Form A 1 Form B type applies.

## REFERENCE DATA

### 1. Maximum switching power



### 2. Life curve



### 3. Coil temperature rise

Measured portion: Inside the coil  
 Ambient temperature: 25°C 77°F, 85°C 185°F  
 Contact current: 35 A/0 A

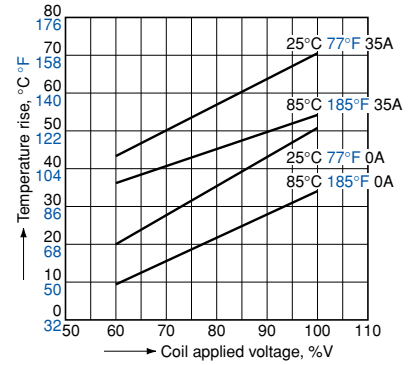

### 4. Ambient temperature characteristics

Tested sample: AHES3191, 6 pcs.



## DIMENSIONS (mm inch)

The CAD data of the products with a **CAD Data** mark can be downloaded from: <http://industrial.panasonic.com/ac/e/>

### 1.2 Form A type

**CAD Data**



### Schematic (Bottom view)

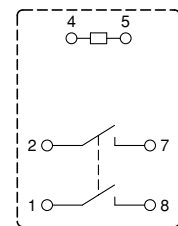

### Recommended PC board pattern (Bottom view)

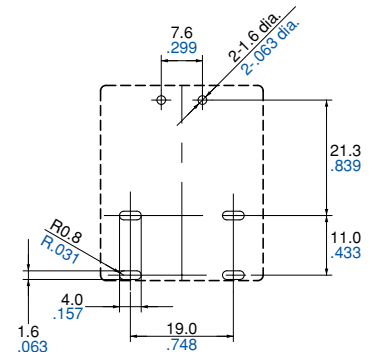

2. 2 Form A 1 Form B type

CAD Data

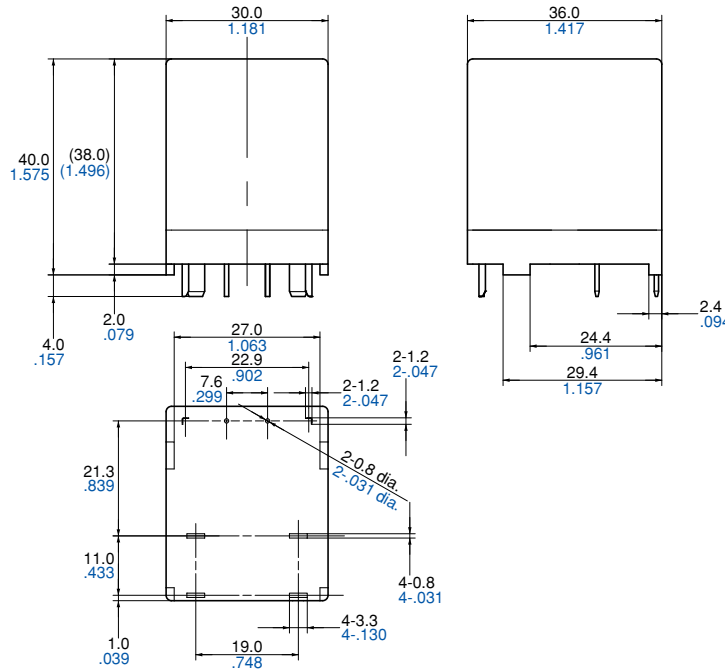

General tolerance:  $\pm 0.3 \pm 0.12$

Schematic (Bottom view)

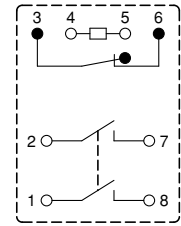

Recommended PC board pattern (Bottom view)

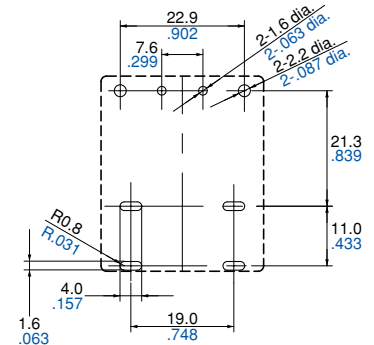

Tolerance:  $\pm 0.1 \pm 0.04$

SAFETY STANDARDS

Item	Certification	File No.	N.O. contact (Form A contact)			N.C. contact (Form B contact)		
			Contact rating	Temp.	Cycles	Contact rating	Temp.	Cycles
Standard type (AHES*19*)	UL/C-UL (Recognized)	E43149	35A, 277VAC, Resistive	85°C 185°F	3×10 <sup>4</sup>	—	—	—
			20A, 277VAC, Resistive	85°C 185°F	10 <sup>5</sup>	1A, 30VDC, Resistive	85°C 185°F	10 <sup>5</sup>
	VDE (Certified)	40042442	15A, 480VAC, Resistive	85°C 185°F	10 <sup>5</sup>	1A, 277VAC, Resistive	85°C 185°F	10 <sup>5</sup>
			TV-8	40°C 104°F	25×10 <sup>3</sup>	DC-13: 1A, 24VDC, L/R = 48ms	85°C 185°F	8×10 <sup>4</sup>
2 Form A	VDE (Certified)	40042442	AC-7a: 35A, 250VAC, cosφ = 0.8	85°C 185°F	3×10 <sup>4</sup>	—	—	—
2 Form A 1 Form B			AC-3: 12A, 230VAC, cosφ = 0.45	85°C 185°F	3×10 <sup>4</sup>	—	—	—
2 Form A 1 Form B	VDE (Certified)	40042442	AC-3: 8A, 480VAC, cosφ = 0.45	85°C 185°F	3×10 <sup>4</sup>	—	—	—
2 Form A 1 Form B			AC-3: 8A, 480VAC, cosφ = 0.45	85°C 185°F	3×10 <sup>4</sup>	DC-13: 1A, 24VDC, L/R = 48ms	85°C 185°F	8×10 <sup>4</sup>

Item	Certification	File No.	N.O. contact (Form A contact)			N.C. contact (Form B contact)		
			Contact rating	Temp.	Cycles	Contact rating	Temp.	Cycles
Long life type (AHES*29*)	UL/C-UL (Recognized)	E43149	35A, 277VAC, Resistive	85°C 185°F	5×10 <sup>4</sup>	—	—	—
			20A, 277VAC, Resistive	85°C 185°F	2×10 <sup>5</sup>	1A, 30VDC, Resistive	85°C 185°F	10 <sup>5</sup>
	VDE (Certified)	40042442	15A, 480VAC, Resistive	85°C 185°F	10 <sup>5</sup>	1A, 277VAC, Resistive	85°C 185°F	10 <sup>5</sup>
			TV-10	40°C 104°F	25×10 <sup>3</sup>	DC-13: 1A, 24VDC, L/R = 48ms	85°C 185°F	8×10 <sup>4</sup>
2 Form A	VDE (Certified)	40042442	AC-7a: 35A, 250VAC, cosφ = 0.8	85°C 185°F	3×10 <sup>4</sup>	—	—	—
2 Form A 1 Form B			AC-3: 12A, 230VAC, cosφ = 0.45	85°C 185°F	3×10 <sup>4</sup>	—	—	—
2 Form A 1 Form B	VDE (Certified)	40042442	AC-3: 8A, 480VAC, cosφ = 0.45	85°C 185°F	3×10 <sup>4</sup>	—	—	—
2 Form A 1 Form B			AC-3: 8A, 480VAC, cosφ = 0.45	85°C 185°F	3×10 <sup>4</sup>	DC-13: 1A, 24VDC, L/R = 48ms	85°C 185°F	8×10 <sup>4</sup>

EN/IEC VDE Certified INSULATION CHARACTERISTIC (IEC61810-1)

Item	Characteristic (Form A contact)
Clearance/Creepage distance (IEC61810-1)	Min. 5.5mm .217inch/8.0mm .315inch
Category of protection (IEC61810-1)	RT II
Tracking resistance (IEC60112)	PTI 175
Insulation material group	III a
Over voltage category	III
Rated voltage	250V
Pollution degree	3
Type of insulation (Between contact and coil)	Reinforced insulation
Type of insulation (Between open contacts)	Full disconnection

## NOTES

1. For cautions for use, please refer to our web site.

([https://www3.panasonic.biz/ac/e/control/relay/cautions\\_use/index.jsp](https://www3.panasonic.biz/ac/e/control/relay/cautions_use/index.jsp))

2. When coil holding voltage controlled by PWM, check coil holding voltage and operation of relay under the actual condition.

### 3. Usage, transport and storage conditions

1) Temperature:

–40 to +55°C –40 to +131°F (When applied coil holding voltage is 30% to 110%V of nominal coil voltage)

–40 to +85°C –40 to +185°F (When applied coil holding voltage is 30% to 60%V of nominal coil voltage or storage)

2) Humidity: 5 to 85% RH (Not freezing and condensing at low temperature)

In addition the humidity range depends on temperature. The allowable ranges are as follows;

3) Air pressure: 86 to 106 kPa

Allowable range of temperature and humidity for operation, transport and storage.

[Coil holding voltage: 30% to 110%V]

[Coil holding voltage: 30% to 60%V]



### 4. Solder and cleaning conditions

1) Please obey the following conditions when soldering automatically.

(1) Pre-heating: within 120°C 248°F (solder surface terminal portion) and within 120 seconds

(2) Soldering iron: 260°C±5°C 500°F±41°F (solder temperature) and within 10 seconds (soldering time)

2) In case of manual soldering, following conditions should be observed.

- Max. 270°C 518°F (solder temperature) within 10 seconds (soldering time)

- Max. 350°C 662°F (solder temperature) within 5 seconds (soldering time)

\* Effects of soldering heat on the relays vary depending on the PC board. So please confirm actual soldering condition with the PC board used for assembling.

3) Do not clean this relay by immersion, since the relay is not sealed.

Also, be careful not to allow flux to overflow above the PC board or enter the inside of the relay.

---

Please contact .....

**Panasonic Corporation**

Electromechanical Control Business Division

■ 1006, Oaza Kadoma, Kadoma-shi, Osaka 571-8506, Japan  
[industrial.panasonic.com/ac/e/](http://industrial.panasonic.com/ac/e/)

**Panasonic**<sup>®</sup>

©Panasonic Corporation 2016

# Mouser Electronics

Authorized Distributor

Click to View Pricing, Inventory, Delivery & Lifecycle Information:

## Panasonic:

[AHES3191](#) [AHES4190](#) [AHES4195](#) [AHES4293](#) [AHES4193](#) [AHES3195](#) [AHES4290](#) [AHES4292](#) [AHES3292](#)  
[AHES3291](#) [AHES4192](#) [AHES4291](#) [AHES3295](#) [AHES3190](#) [AHES3290](#) [AHES3293](#) [AHES3192](#) [AHES3193](#)  
[AHES4295](#) [AHES4191](#)





Компания «ЭлектроПласт» предлагает заключение долгосрочных отношений при поставках импортных электронных компонентов на взаимовыгодных условиях!

Наши преимущества:

- Оперативные поставки широкого спектра электронных компонентов отечественного и импортного производства напрямую от производителей и с крупнейших мировых складов;
- Поставка более 17-ти миллионов наименований электронных компонентов;
- Поставка сложных, дефицитных, либо снятых с производства позиций;
- Оперативные сроки поставки под заказ (от 5 рабочих дней);
- Экспресс доставка в любую точку России;
- Техническая поддержка проекта, помощь в подборе аналогов, поставка прототипов;
- Система менеджмента качества сертифицирована по Международному стандарту ISO 9001;
- Лицензия ФСБ на осуществление работ с использованием сведений, составляющих государственную тайну;
- Поставка специализированных компонентов (Xilinx, Altera, Analog Devices, Intersil, Interpoint, Microsemi, Aeroflex, Peregrine, Syfer, Eurofarad, Texas Instrument, Miteq, Cobham, E2V, MA-COM, Hittite, Mini-Circuits, General Dynamics и др.);

Помимо этого, одним из направлений компании «ЭлектроПласт» является направление «Источники питания». Мы предлагаем Вам помощь Конструкторского отдела:

- Подбор оптимального решения, техническое обоснование при выборе компонента;
- Подбор аналогов;
- Консультации по применению компонента;
- Поставка образцов и прототипов;
- Техническая поддержка проекта;
- Защита от снятия компонента с производства.



#### Как с нами связаться

**Телефон:** 8 (812) 309 58 32 (многоканальный)

**Факс:** 8 (812) 320-02-42

**Электронная почта:** [org@eplast1.ru](mailto:org@eplast1.ru)

**Адрес:** 198099, г. Санкт-Петербург, ул. Калинина, дом 2, корпус 4, литера А.