

TOSHIBA BiCD Integrated Circuit Silicon Monolithic

**TB67H410FTG, TB67H410NG****PWM Chopper-Type Brushed DC Motor driver**

The TB67H410 is brushed DC motor driver of a PWM chopper-type. The TB67H410 is a dual channel H-SW driver which can control two brushed DC motors. Moreover, the parallel control function (Large mode) of an output part is built in, and 1ch high current drive is also possible. Fabricated with the BiCD process, the TB67H410 is maximum rated at 50V, 2.5A(2ch)/5.0A(1ch).

**Features**

- Monolithic motor driver using BiCD process.
- Capable of controlling two brushed DC motor.
- 2 drive modes (PWM controlled constant-current/ direct PWM)
- 4 operation modes (Clock-wise/Counter clock-wise/Brake/Stop(Off))
- Low on-resistance output stage (High side+Low side:0.8Ω(typ.))
- High voltage and current (for specification, please refer to absolute maximum ratings and operating ranges.)
- Built-in error detection circuits (Thermal shutdown(TSD), over-current detection (ISD), and power-on reset (POR).
- Built-in regulator allows the TB67H410 to function with a single VM power supply.
- Able to customize PWM (internal chopping) frequency by external components.
- Multi package lineup.

TB67H410FTG: P-WQFN48-0707-0.50-003

TB67H410NG: P-SDIP24-0723-1.78-001

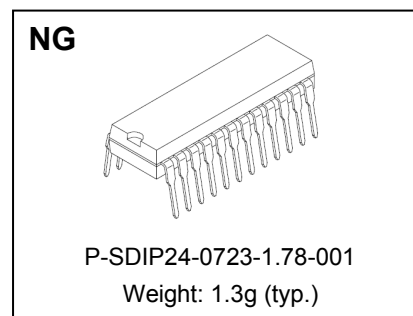
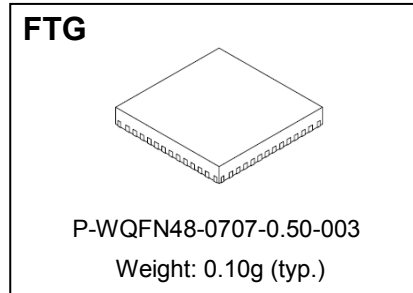

Note: Please be careful about the thermal conditions during use.

### Pin assignment

FTG Type (Top View)

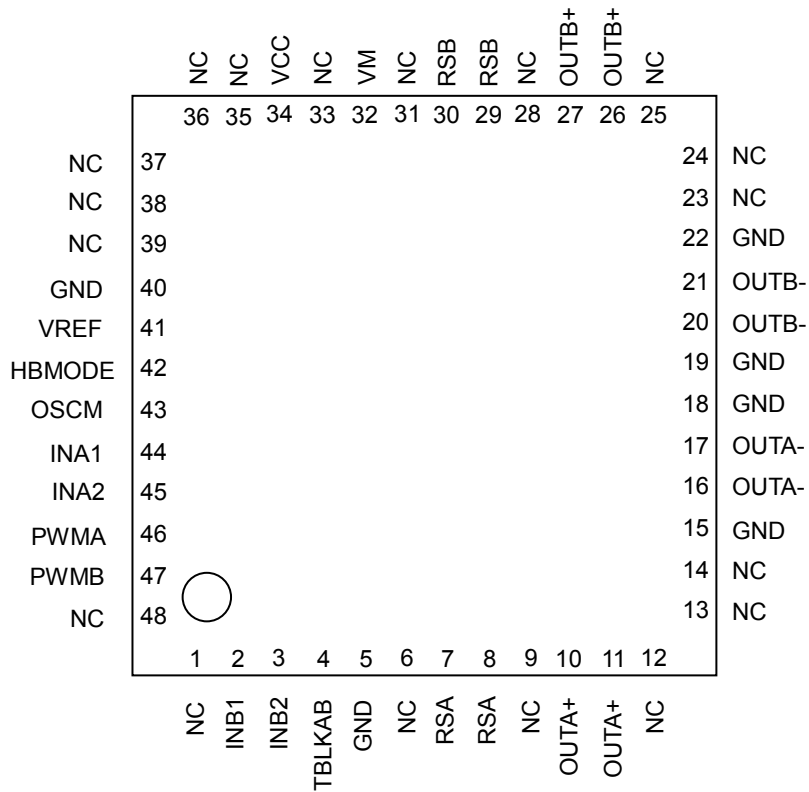

Note: Please connect the corner pad and the exposed pad to the PCB ground pattern when using the QFN package.

NG Type (Top View)

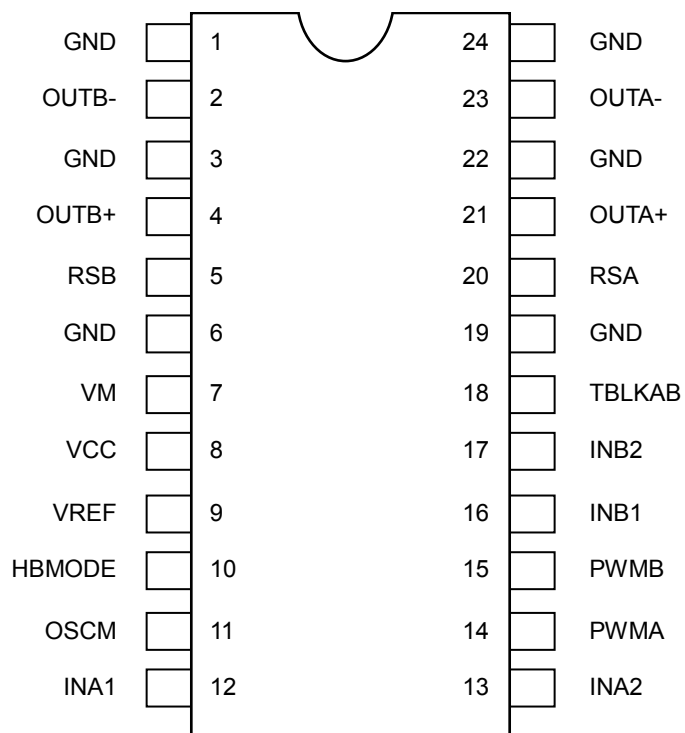

TB67H410 Block Diagram

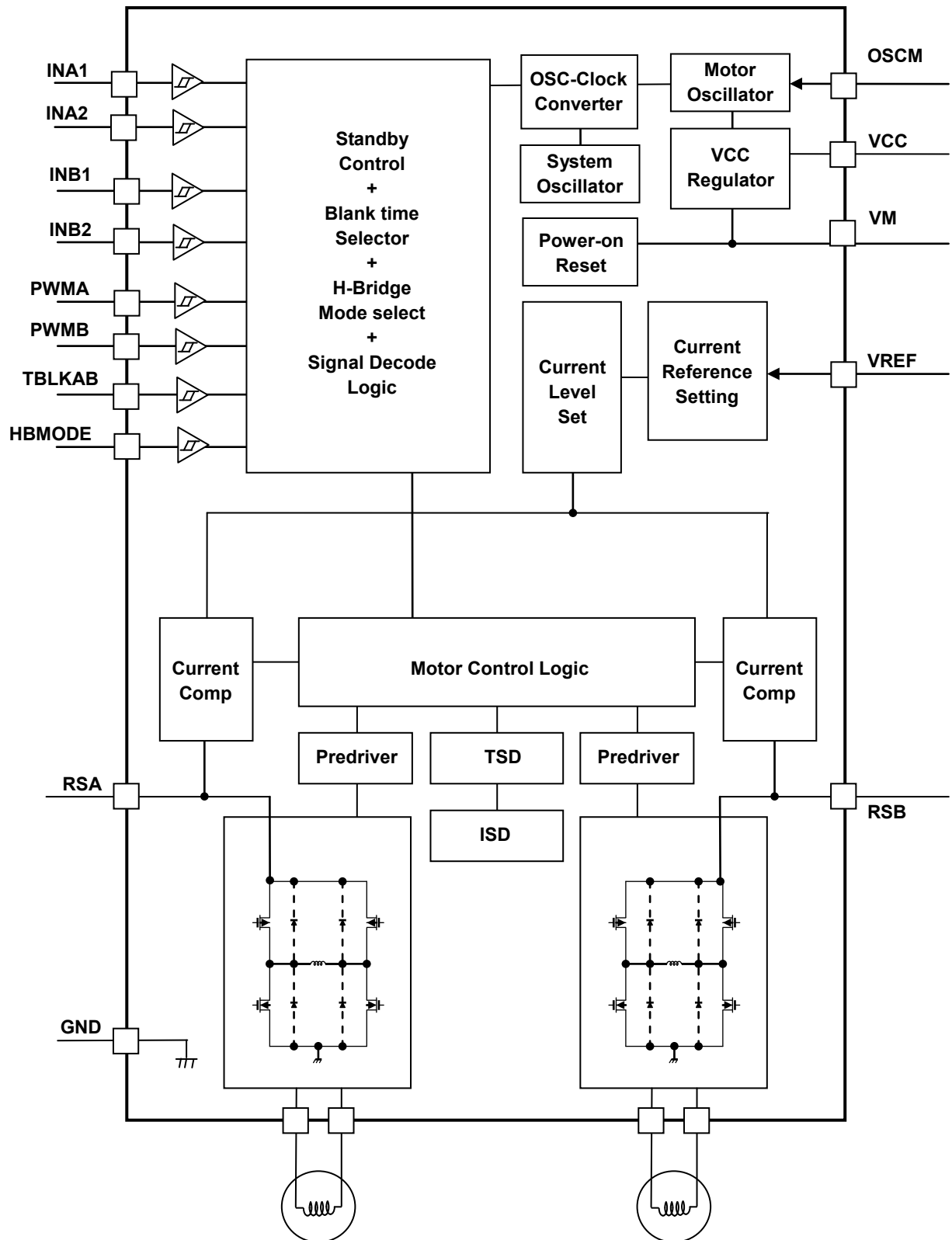

\* Please note that in the block diagram, functional blocks or constants may be omitted or simplified for explanatory purposes.

## Notes:

All the grounding wires of the TB67H410 must run on the solder within the mask of the PCM. It must also be externally terminated at a single point. Also, the grounding method should be considered for efficient heat dissipation.

Careful attention should be paid to the layout of the output, VM and GND traces, to avoid short circuits across output pins or to the power supply or ground. If such a short circuit occurs, the device may be permanently damaged.

Also, the utmost care should be taken for pattern designing and implementation of the device since it has power supply pins (VM, RS, OUT, GND) through which a particularly large current may run. If these pins are wired incorrectly, an operation error may occur or the device may be destroyed.

The logic input pins must also be wired correctly. Otherwise, the device may be damaged owing to a current running through the IC that is larger than the specified current.

**Pin functions****TB67H410FTG (WQFN48)**

Pin No.1-28

Pin No.	Pin name	Function
1	NC	Not connected
2	INB1	Bridge B operation mode set pin 1
3	INB2	Bridge B operation mode set pin 2
4	TBLKAB	Bridge A and B Digital tBLK setting
5	GND	Ground pin
6	NC	Not connected
7	RSA(*)	Bridge A sense output
8	RSA(*)	Bridge A sense output
9	NC	Not connected
10	OUTA+(*)	Bridge A + output
11	OUTA+(*)	Bridge A + output
12	NC	Not connected
13	NC	Not connected
14	NC	Not connected
15	GND	Ground pin
16	OUTA-(*)	Bridge A - output
17	OUTA-(*)	Bridge A - output
18	GND	Ground pin
19	GND	Ground pin
20	OUTB-(*)	Bridge B - output
21	OUTB-(*)	Bridge B - output
22	GND	Ground pin
23	NC	Not connected
24	NC	Not connected
25	NC	Not connected
26	OUTB+(*)	Bridge B + output
27	OUTB+(*)	Bridge B + output
28	NC	Not connected

Pin No.29-48

Pin No.	Pin name	Function
29	RSB(*)	Bridge B sense output
30	RSB(*)	Bridge B sense output
31	NC	Not connected
32	VM	Motor Voltage supply
33	NC	Not connected
34	VCC	Internal regulator voltage monitor
35	NC	Not connected
36	NC	Not connected
37	NC	Not connected
38	NC	Not connected
39	NC	Not connected
40	GND	Ground pin
41	VREF	Current customize for Bridge A and B
42	HBMODE	H-Bridge operation mode set
43	OSCM	Oscillator frequency set pin
44	INA1	Bridge A operation mode set pin 1
45	INA2	Bridge A operation mode set pin 2
46	PWMA	Bridge A short brake input
47	PWMB	Bridge B short brake input
48	NC	Not connected

• Please do not connect any pattern to the NC pin.

•\* : Please connect the pins with the same names, at the nearest point of the device.

**Pin explanation****TB67H410NG (SDIP24)**

Pin No.1-24

Pin No.	Pin name	Function
1	GND	Ground pin
2	OUTB-	Bridge B - output
3	GND	Ground pin
4	OUTB+	Bridge B + output
5	RSB	Bridge B sense output
6	GND	Ground pin
7	VM	Motor Voltage supply
8	VCC	Internal regulator voltage monitor
9	VREF	Current customize for Bridge A and B
10	HBMODE	H-Bridge operation mode set
11	OSCM	Oscillator frequency set pin
12	INA1	Bridge A operation mode set pin 1
13	INA2	Bridge A operation mode set pin 2
14	PWMA	Bridge A short brake input
15	PWMB	Bridge B short brake input
16	INB1	Bridge B operation mode set pin 1
17	INB2	Bridge B operation mode set pin 2
18	TBLKAB	Bridge A and B Digital tBLK setting
19	GND	Ground pin
20	RSA	Bridge A sense output
21	OUTA+	Bridge A + output
22	GND	Ground pin
23	OUTA-	Bridge A - output
24	GND	Ground pin



### Equivalent circuit (TB67H410)

Pin name	Input/Output signal	Equivalent circuit
INA1 INA2 PWMA INB1 INB2 PWMB TBLKAB HBMODE	Logic input (VIH/VIL)  VIH: 2.0V(min) to 5.5V(max) VIL : 0V(min) to 0.8V(max)	
VCC  VREF	VCC regulator specification 4.75V(min) to 5.0V(typ.) to 5.25V(max)  VREF voltage range 0V to 4.0V	
OSCM	OSCM setup frequency 0.64MHz(min) to 1.12MHz(typ.) to 2.4MHz(max)	
OUTA+ OUTA- OUTB+ OUTB- RSA RSB	VM operation range 10V(min) to 47V(max)  OUTPUT pin voltage range 10V(min) to 47V(max)	

Please note that in the equivalent input circuit, functional blocks or constants may be omitted or simplified for explanatory purposes.

## Function mode (Brushed DC Motor Mode)

### Logic input function table

(1) INA1, INA2

These pins set the drive mode for Bridge A

	PWMA	INA1	INA2	OUTA+	OUTA-	Function
INPUT	L	L	L	OFF (Hi-Z)	OFF (Hi-Z)	STANDBY MODE (*)
	H					STOP(OFF)
	L	L	H	L	L	Short brake
	H					CCW (Counter clock-wise)
	L	H	L	L	L	Short brake
	H					CW (Clock-wise)
	L	H	H	L	L	Short brake
	H					

(2) INB1, INB2

These pins set the drive mode for Bridge B

	PWMB	INB1	INB2	OUTB+	OUTB-	Function
INPUT	L	L	L	OFF (Hi-Z)	OFF (Hi-Z)	STANDBY MODE (*)
	H					STOP(OFF)
	L	L	H	L	L	Short brake
	H					CCW (Counter clock-wise)
	L	H	L	L	L	Short brake
	H					CW (Clock-wise)
	L	H	H	L	L	Short brake
	H					

\*Note: The standby mode is only enabled when all 6 logic input pins (INA1,INA2,PWMA,INB1, INB2,PWMB) are set to Low level. If either of the 6pins are set to High level, the standby mode will be canceled.

(3) TBLKAB

This pin will set the noise rejection time.

TBLKAB	TBLK noise rejection time
L	Digital tBLK = fOSCM×4clk
H	Digital tBLK = fOSCM×6clk

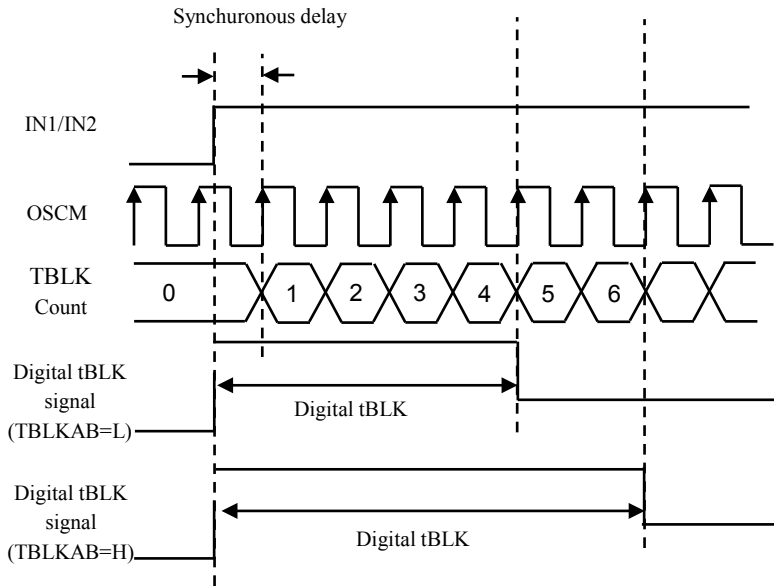

Please note that the timing charts or constants may be omitted or simplified for explanatory purposes.

The Digital tBLK is used to avoid error judgment of varistor recovery current that occurs in charge drive mode when H-bridges are used with DC motors. The Digital tBLK time can be controlled with TBLKAB pin.

By setting Digital tBLK, direct PWM control and constant-current control is possible, but the motor current will rise above the predefined current level (NF) while digital tBLK is active.

Besides Digital tBLK, Analog tBLK(400ns typ.) settled by an internal constant of IC is also attached.

● Digital tBLK timing for Brushed DC Motor

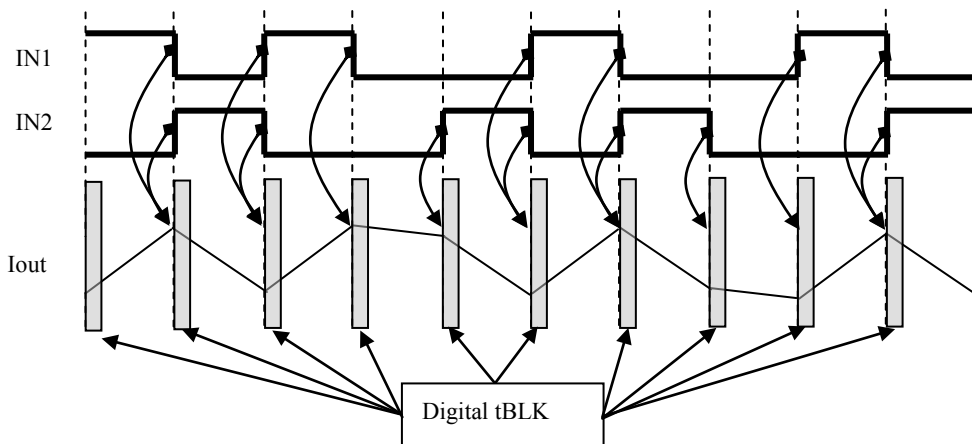

The Digital tBLK is inserted at the beginning of each charge period of the constant current chopping, and also when either the INA1/A2/B1/B2 is switched.

Timing charts may be simplified for explanatory purpose.

## (4) HBMODE

This pin sets the H-Bridge operation mode.

Pin name	Function	Input	Setting
HBMODE	H-Bridge operation setting	Low	Small mode
		High	Large mode

Note: When using the Large mode, please make sure that the impedance between A channel and B channel is balanced. Also, make sure that the output pins (OUTA+ and OUTA-, OUTB+ and OUTB-), RS pins (RSA and RSB) are connected to each other when using the Large mode.

Note: Please set the HBMODE to Low or High with the PCB pattern. (Do not change the logic input level during operation.)

Note: When the HB\_MODE pin is set to High level, the motor control will be controlled by the Ach inputs (INA1,INA2,PWMA). The Bch inputs will be invalid. (When using the TB67H410 in Large mode, setting the INB1,INB2,PWMB to Low level is preferred.) TBLKAB pin is effective in both Small/Large mode(HBMODE=L/H).

## H-Bridge connection example

### ●2 Small DC motor operation setting example (HBMODE=L)

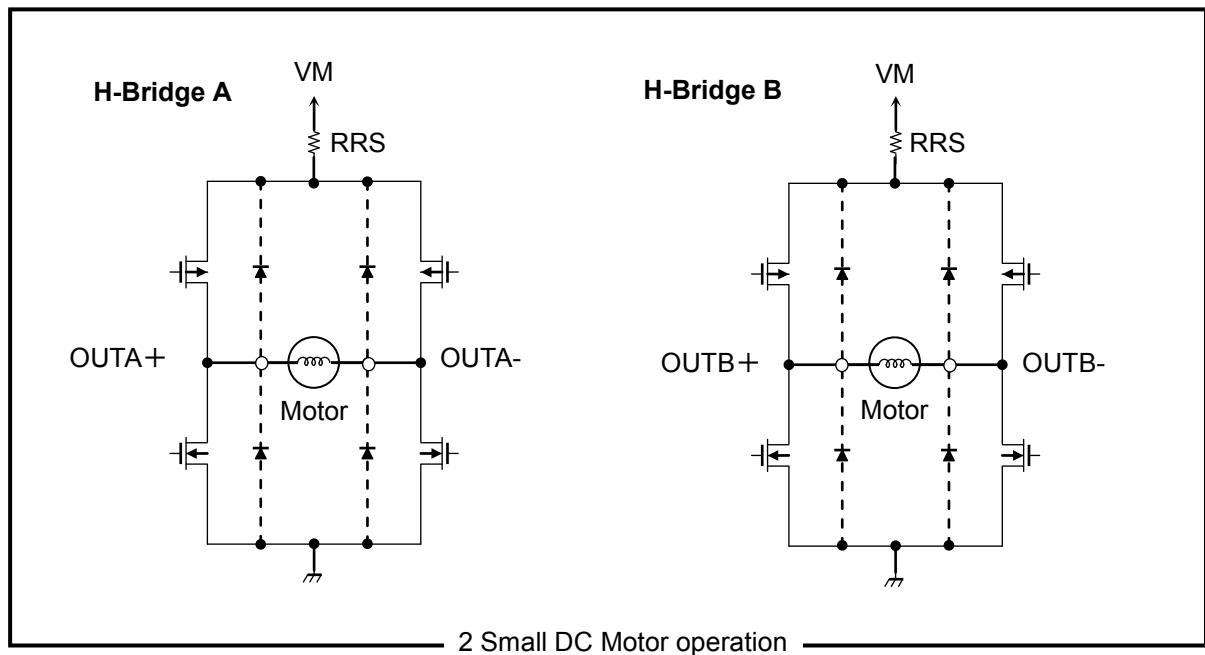

- 1 Large DC motor operation setting example (HBMODE=H)

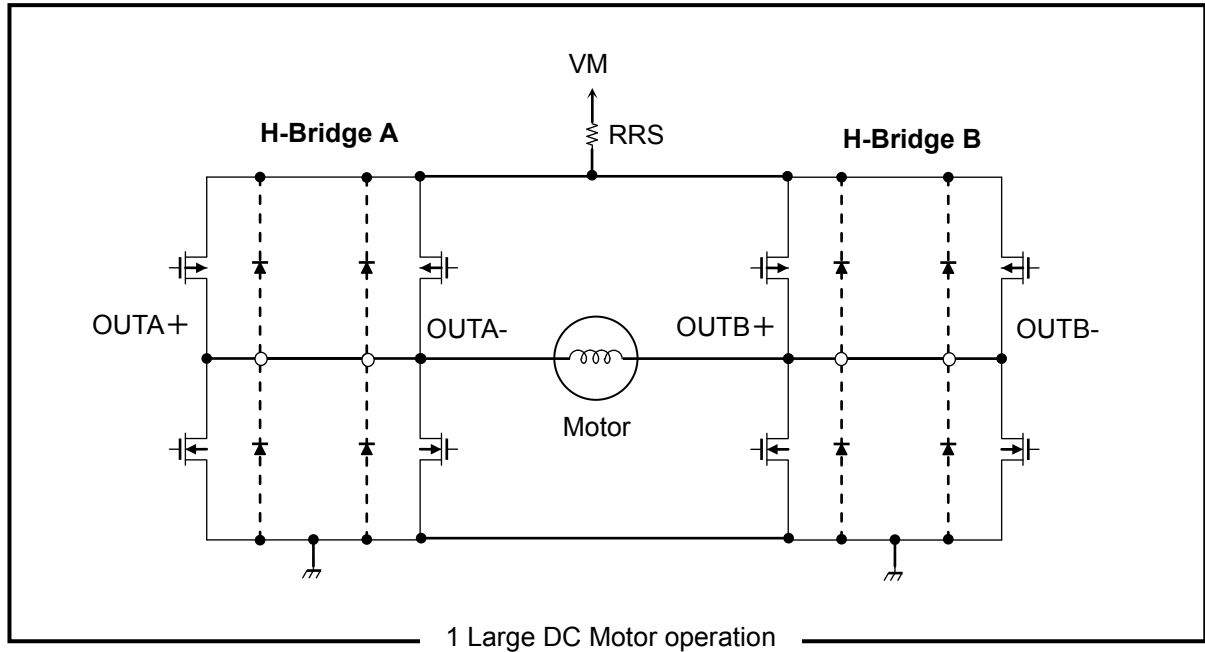

Please note that in the equivalent input circuit, functional blocks or constants may be omitted or simplified for explanatory purposes.

DC Small mode->H-Bridge A and B will operate separately (for two brushed DC motor operation)

DC Large mode->H-Bridge A and B will operate as a single H-Bridge. (for one brushed DC motor operation)

\*When the HBMODE is set to High level, the pin function will be as follows.

Pin	HBMODE=H(Large mode)
INA1	INL1
INA2	INL2
PWMA	PWML
PWMB	Don't care (Motor will be Controlled by INL1,INL2,PWML pins)
INB1	
INB2	
TBLKAB	TBLKL
RSA	RSL
RSB	
OUTA+	OUTL+
OUTA-	
OUTB+	OUTL-
OUTB-	

Note: Please connect the "RSA and RSB", "OUTA+ and OUTA-", and "OUTB+ and OUTB-" when using the Large mode operation.

## About motor control (constant current control)

### About the current waveform of Mixed Decay Mode, and a setting

In the case of constant current control, the rate of Mixed Decay Mode which determines current Ripple is fixed to 37.5%.

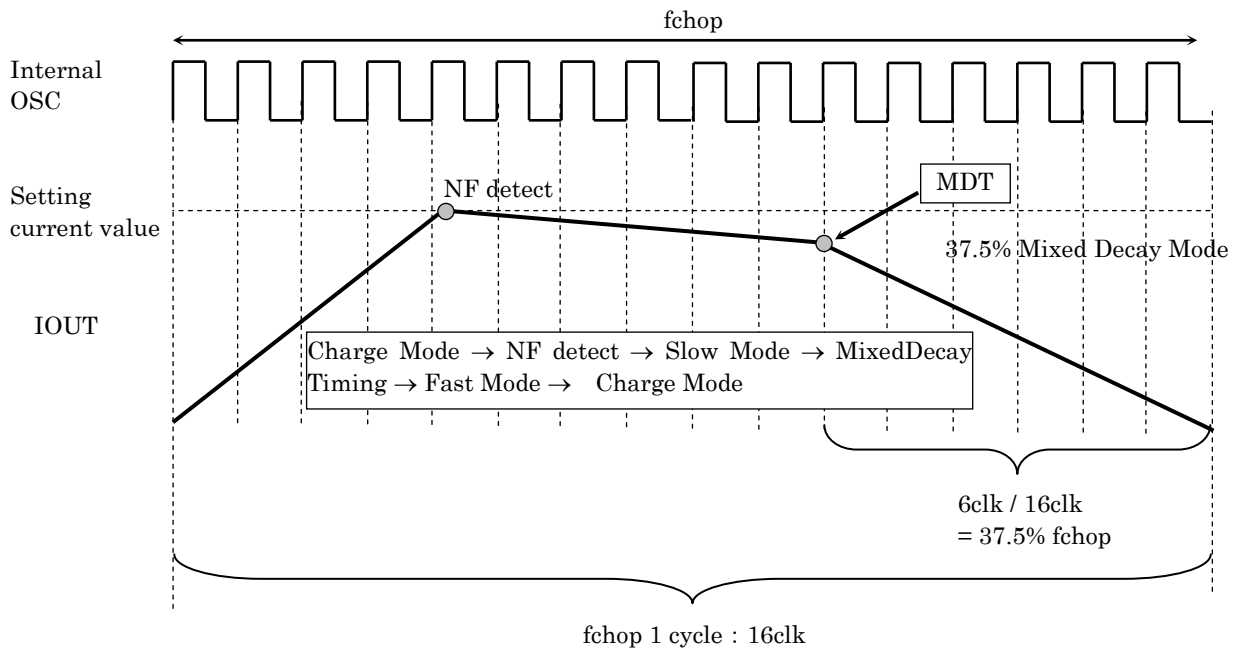

### Mixed Decay Mode current waveform

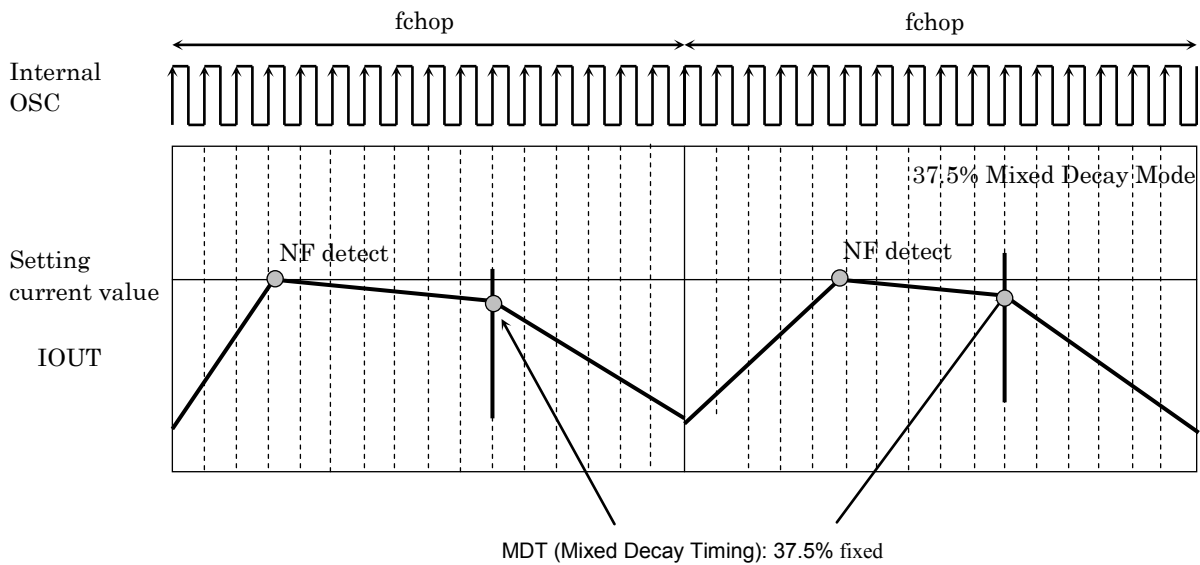

Timing charts may be simplified for explanatory purposes.

● **Current Waveform in Mixed (Slow + Fast) Decay Mode**

- When a current value increases (Mixed-Decay point is fixed to 37.5%)

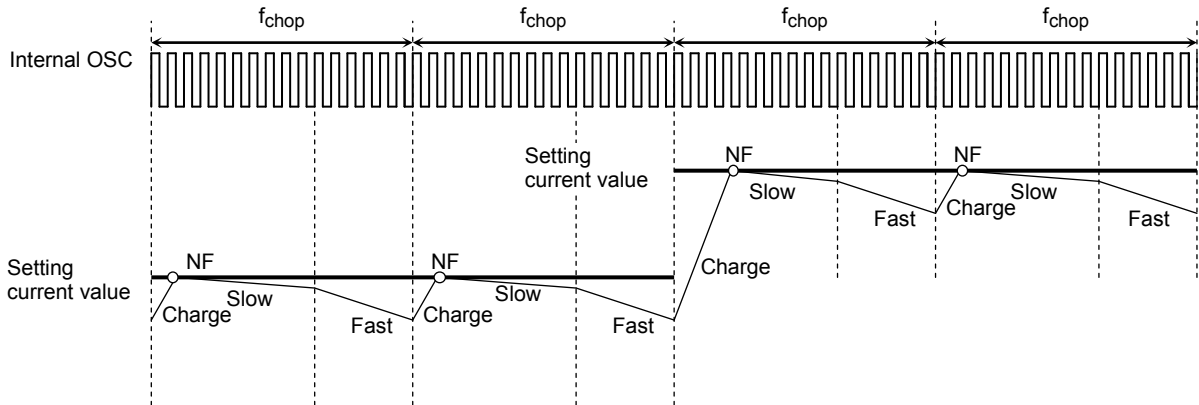

- When a current value decreases (Mixed-Decay point is fixed to 37.5%)

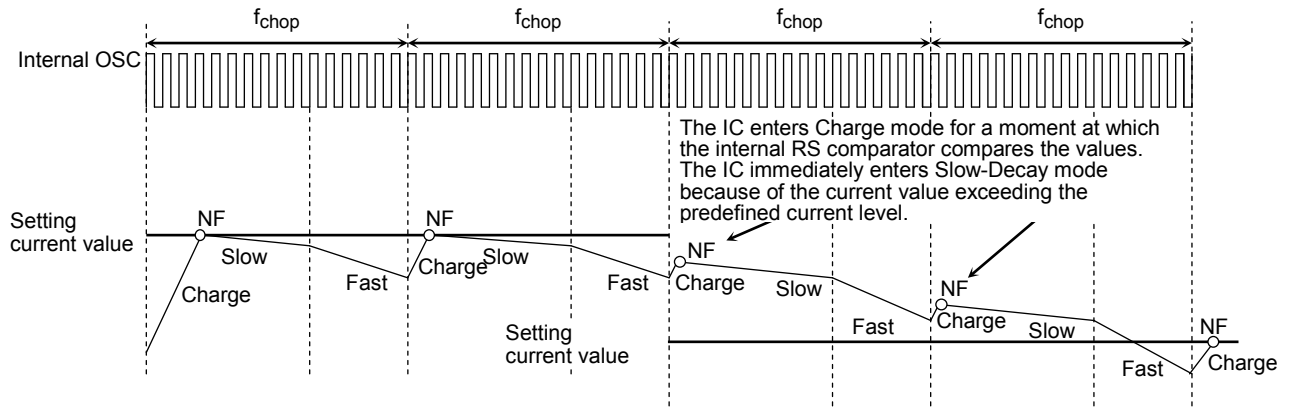

The Charge period starts as the internal oscillator clock starts counting. When the output current reaches the predefined current level, the internal RS comparator detects the predefined current level (NF); as a result, the IC enters Slow-Decay mode.

The TB67H410 transits from Slow-Decay mode to Fast-Decay mode at the point 37.5% of a PWM frequency (one chopping frequency) remains in a whole PWM frequency period (on the rising edge of the 11th clock of the OSCM clock).

When the OSCM pin clock counter clocks 16 times, the Fast-Decay mode ends; and at the same time, the counter is reset, which brings the TB67H410 into Charge mode again.

Note: These figures are intended for illustrative purposes only. If designed more realistically, they would show transient response curves.

Timing charts may be simplified for explanatory purposes.

## Output Transistor Operation Mode

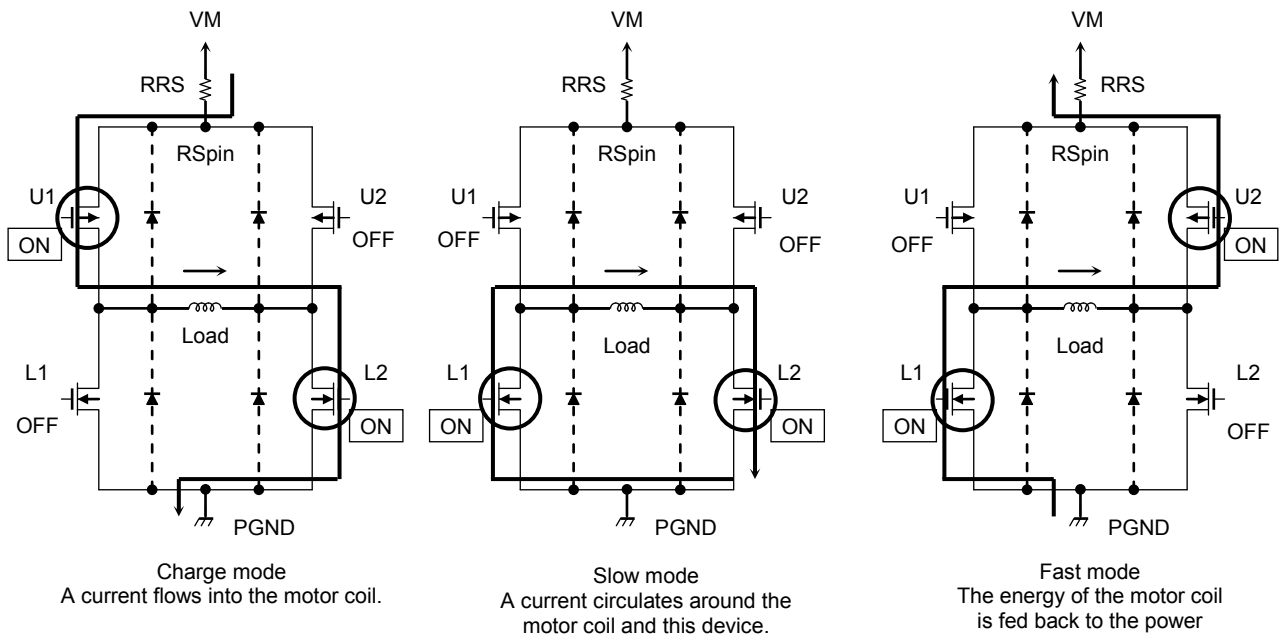

## Output Transistor Operational Function

MODE	U1	U2	L1	L2
CHARGE	ON	OFF	OFF	ON
SLOW	OFF	OFF	ON	ON
FAST	OFF	ON	ON	OFF

Note: The parameters shown in the table above are examples when the current flows in the directions shown in the figures above. For the current flowing in the reverse direction, the parameters change as shown in the table below.

MODE	U1	U2	L1	L2
CHARGE	OFF	ON	ON	OFF
SLOW	OFF	OFF	ON	ON
FAST	ON	OFF	OFF	ON

This IC controls the motor current to be constant by 3 modes listed above.

The equivalent circuit diagrams may be simplified or some parts of them may be omitted for explanatory purposes.



## Calculation of the Predefined Output Current

For PWM constant-current control, this IC uses a clock generated by the OSCM oscillator.

The peak output current (Setting current value) can be set via the current-sensing resistor (RRS) and the reference voltage (Vref), as follows:

$$I_{out(max)} = V_{ref(gain)} \times \frac{V_{ref(V)}}{R_{RS}(\Omega)}$$

Vref(gain) : the Vref decay rate is 1/ 5.0 (typ.)

For example : In the case of a 100% setup

when Vref = 3.0 V, Torque=100%,RS=0.51Ω, the motor constant current (Setting current value) will be calculated as:

$$I_{out} = 3.0V / 5.0 / 0.51\Omega = 1.18 \text{ A}$$

## Calculation of the OSCM oscillation frequency (chopper reference frequency)

An approximation of the OSCM oscillation frequency (fOSCM) and chopper frequency (fchop) can be calculated by the following expressions.

$$f_{OSCM} = 1 / [0.56 \times \{C \times (R1 + 500)\}]$$

.....C,R1: External components for OSCM (C=270pF , R1=5.1kΩ => About fOSCM= 1.12MHz(Typ.))

$$f_{chop} = f_{OSCM} / 16$$

.....fOSCM=1.12MHz => fchop =About 70kHz(typ.)

If chopping frequency is raised, Ripple of current will become small and wave-like reproducibility will improve. However, the gate loss inside IC goes up and generation of heat becomes large.

By lowering chopping frequency, reduction in generation of heat is expectable. However, Ripple of current may become large. It is a standard about about 70 kHz. A setup in the range of 50 to 100 kHz is recommended.

**Absolute maximum ratings (Ta = 25°C)**

Characteristics	Symbol	Rating	Unit	Note	
Motor power supply	VM	50	V	-	
Motor output voltage	Vout	50	V	-	
Motor output current	Iout(S)	2.5	A	(Small mode) Note 1	
	Iout(L)	5.0	A	(Large mode) Note 1	
VCC voltage	VCC	6.0	V	When externally applied.	
Logic input voltage	VIN(H)	6.0	V	-	
	VIN(L)	-0.4	V	-	
Vref input voltage	Vref	GND~4.2	V	-	
Power dissipation	FTG	PD	1.3	W	Note2
	NG		1.78		
Operating temperature	TOPR	-20~85	°C	-	
Storage temperature	TSTR	-55~150	°C	-	
Junction temperature	Tj(max)	150	°C	-	

Note 1: While in use, please make sure to take the heat generation matter into consideration, and use below 70% of the absolute maximum ratings (Iout(S)≤1.75 A, Iout(L)≤3.5A) as a reference. Operating conditions (such as surrounding temperature or board conditions) may limit the operating current. (Depends on the heat conditions.)

Note 2: The value in the state where it is not mounted on the board. When Ta exceeds 25°C, FTG type is necessary to do the derating with 10.4mW/°C ,and NG type is necessary to do the derating with 14.2mW/°C.

Ta: Ambient temperature.

Topr: Operating ambient temperature.

Tj: Operating junction temperature. The maximum junction temperature is limited by the thermal shutdown.

Use the maximum junction temperature (Tj) at 120°C or less. The maximum current cannot be used under certain thermal conditions.

**Caution) Absolute maximum ratings**

The absolute maximum ratings of a semiconductor device are a set of ratings that must not be exceeded, even for a moment. Do not exceed any of these ratings.

Exceeding the rating (s) may cause device breakdown, damage or deterioration, and may result in injury by explosion or combustion.

The value of even one parameter of the absolute maximum ratings should not be exceeded under any circumstances. The TB67H410 does not have overvoltage detection circuit. Therefore, the device is damaged if a voltage exceeding its rated maximum is applied.

All voltage ratings, including supply voltages, must always be followed. The other notes and considerations described later should also be referred to.

**Operating Ranges (Ta=-20 to 85°C)**

Characteristics	Symbol	Min	Typ.	Max	Unit	Note
VM power supply	VM	10	24	47	V	
Motor output current	Iout(S)	-	1.0	2.5	A	Small mode
	Iout(L)	-	2.0	5.0	A	Large mode
Logic input voltage	VIN(H)	2.0	-	5.5	V	Logic [High] level
	VIN(L)	GND	-	0.8	V	Logic [Low] level
Logic input frequency	fLOGIC	-	-	400	kHz	IN1,IN2,PWM
PWM signal frequency	fchop(range)	40	70	150	kHz	
Vref input voltage	Vref	GND	2.0	4.0	V	

Note: The actual maximum current may be limited by the operating environment (operating conditions such operating duration, or by the surrounding temperature or board heat dissipation). Determine a realistic maximum current by calculating the heat generated under the operating environment.

## Electrical Specifications 1 (Ta=25°C, VM=24V, unless specified otherwise)

Characteristics	Symbol	Note	Min	Typ.	Max	Unit	
Logic input voltage	High	VIN(H)	Logic input pins(Note)	2	-	5.5	V
	Low	VIN(L)	Logic input pins(Note)	0	-	0.8	V
Logic input hysteresis voltage	VIN(HYS)	Logic input pins(Note)	100	-	300	mV	
Logic input current	High	IIN(H)	Logic input pins:3.3V	-	33	-	μA
	Low	IIN(L)	Logic input pins:0V	-	-	1	μA
Power consumption	IM1	Output:OPEN, Standby mode	-	2	3.5	mA	
	IM2	Output:OPEN, PWM=H, IN1, IN2=Low	-	3.5	5.5	mA	
	IM3	Output:OPEN	-	5.5	7	mA	
Output leakage current	High	IOH	VRS=VM=50V, Vout=0V	-	-	1	μA
	Low	IOL	VRS=VM=Vout=50V	1	-	-	μA
Output current channel differential	ΔIout1	Bridge A,B differential	-5	0	5	%	
Output current accuracy	ΔIout2	Iout=1.5A	-5	0	5	%	
RS pin current	IRS	VRS=VM=24V	0	-	10	μA	
Drain-source ON-resistance (High side + low side)	Ron(H+L)	Tj=25°C, Forward direction High side+Low side Small mode	-	0.8	0.9	Ω	

Note: VIN(L) is defined as the VIN voltage that causes the outputs (OUTA+, OUTA-, OUTB+ and OUTB-) to change when a pin under test is gradually raised from 0 V. VIN(H) is defined as the VIN voltage that causes the outputs (OUTA+, OUTA-, OUTB+ and OUTB-) to change when the pin is then gradually lowered.

The difference between VIN(H) and VIN(L) is defined as the VIN(HYS).

Note: The internal circuits are designed to avoid miss-function or leakage current; when the logic signal is applied while the VM voltage is not supplied. But for fail-safe, please control the power supply and logic signal timing correctly.

**Electrical Specifications 2 (Ta=25°C, VM=24V, unless specified otherwise)**

Characteristics	Symbol	Note	Min	Typ.	Max	Unit
Vref input current	Iref	Vref=2.0V	-	0	1	μA
Internal regulator voltage	VCC	ICC=5.0mA	4.75	5.0	5.25	V
Internal regulator current	ICC	VCC=5.0V	-	2.5	5	mA
Vref gain rate	Vref(gain)	Vref=2.0V	1/5.2	1/5.0	1/4.8	—
TSD threshold (Note1)	TjTSD	-	145	160	175	°C
VM power on reset voltage	VMR	-	7.0	8.0	9.0	V
Over current threshold (Note2)	ISD	-	2.6	3.0	4.0	A

**Note 1: Thermal shutdown (TSD) circuit**

When the junction temperature of the device reaches the TSD threshold, the TSD circuit is triggered; the internal reset circuit then turns off the output transistors. Once the TSD circuit is triggered, the device will be set to standby mode, and can be cleared by reasserting the VM power source, or setting to standby mode (INA1,INA2,INB1,INB2,PWMA,PWMB=All Low). The TSD circuit is a backup function to detect a thermal error, therefore is not recommended to be used aggressively.

**Note 2: Over-current shutdown (ISD) circuit**

When the output current reaches the threshold, the ISD circuit is triggered; the internal reset circuit then turns off the output transistors. Once the ISD circuit is triggered, the device will be set to standby mode, and can be cleared by reasserting the VM power source, or setting to standby mode (INA1,INA2,INB1,INB2,PWMA,PWMB=All Low).

**Back-EMF**

While a motor is rotating, there is a timing at which power is fed back to the power supply. At that timing, the motor current recirculates back to the power supply due to the effect of the motor back-EMF.

If the power supply does not have enough sink capability, the power supply and output pins of the device might rise above the rated voltages. The magnitude of the motor back-EMF varies with usage conditions and motor characteristics. It must be fully verified that there is no risk that the TB67H410 or other components will be damaged or fail due to the motor back-EMF.

**Cautions on Overcurrent Shutdown (ISD) and Thermal Shutdown (TSD)**

- The ISD and TSD circuits are only intended to provide temporary protection against irregular conditions such as an output short-circuit; they do not necessarily guarantee the complete IC safety.
- If the device is used beyond the specified operating ranges, these circuits may not operate properly: then the device may be damaged due to an output short-circuit.
- The ISD circuit is only intended to provide a temporary protection against an output short-circuit. If such a condition persists for a long time, the device may be damaged due to overstress. Overcurrent conditions must be removed immediately by external hardware.

**IC Mounting**

Do not insert devices incorrectly or in the wrong orientation. Otherwise, it may cause breakdown, damage and/or deterioration of the device.

## AC Electrical Specification (Ta = 25°C, VM = 24 V, 6.8 mH/5.7 Ω)

Characteristics	Symbol	Note	Min	Typ.	Max	Unit
Minimum phase pulse width	fLOGIC(min)	-	100	-	-	ns
	twp	-	50	-	-	
	twl	-	50	-	-	
Output transistor switching characteristics	tr	-	30	80	130	ns
	tf	-	40	90	140	
	tpLH(LOGIC)	IN1,IN2,PWM - OUT	250	-	1200	
	tpHL(LOGIC)	IN1,IN2,PWM - OUT	250	-	1200	
Analog blanking time	AtBLK	VM=24V,Iout=1.5A Analog tBLK	250	400	550	ns
Digital blanking time	DtBLK(L)	TBLKAB:L, fOSCM=1120kHz	-	3.6	-	μs
	DtBLK(H)	TBLKAB:H, fOSCM=1120kHz	-	5.4	-	μs
OSCM oscillation frequency accuracy	ΔfOSCM	COSC= 270 pF, RO SC =5.1 kΩ	-15	-	+15	%
OSC oscillation reference frequency	fOSCM	COSC= 270 pF, RO SC =5.1 kΩ	952	1120	1288	kHz
Chopping frequency	fchop	Output: Active(Iout=1.5 A), fOSCM = 1120 kHz	-	70	-	kHz

### Timing chart

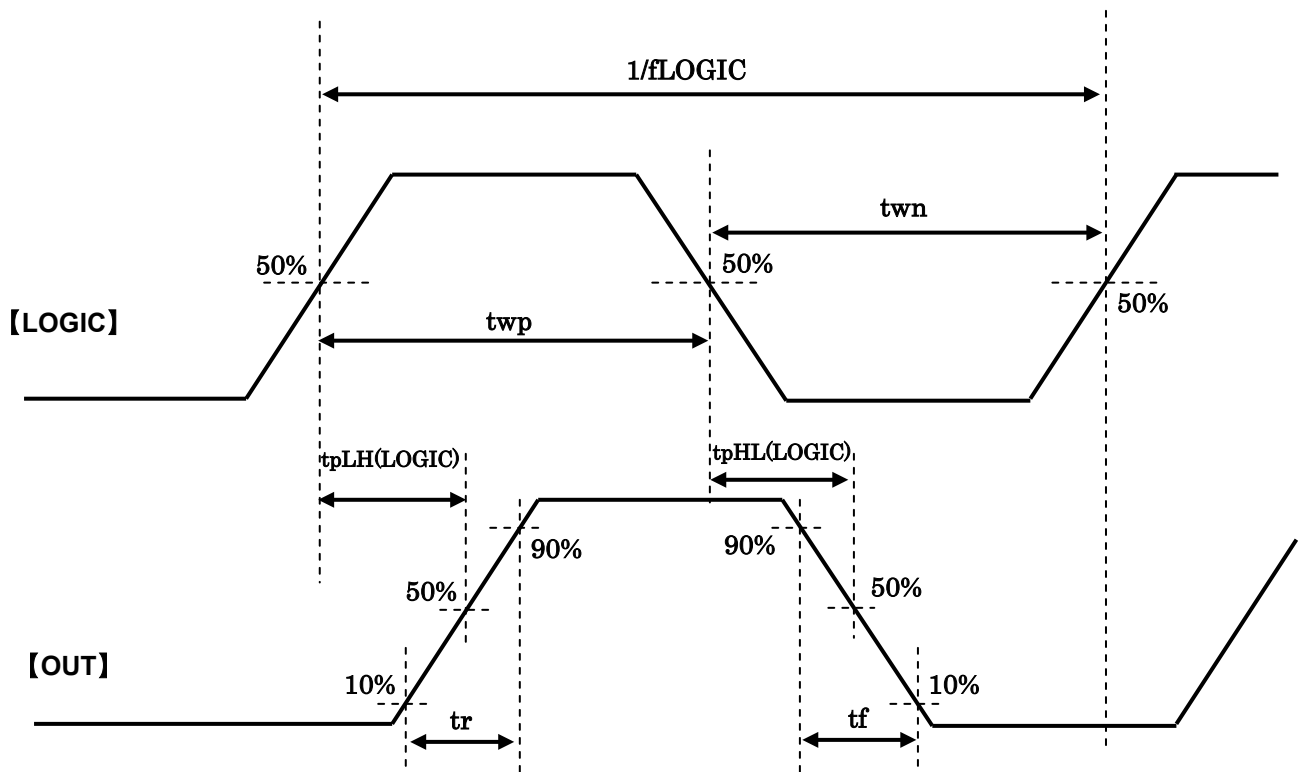

Timing charts may be simplified for explanatory purpose.

### Package Dimensions

P-WQFN48-0707-0.50-003

Unit : mm

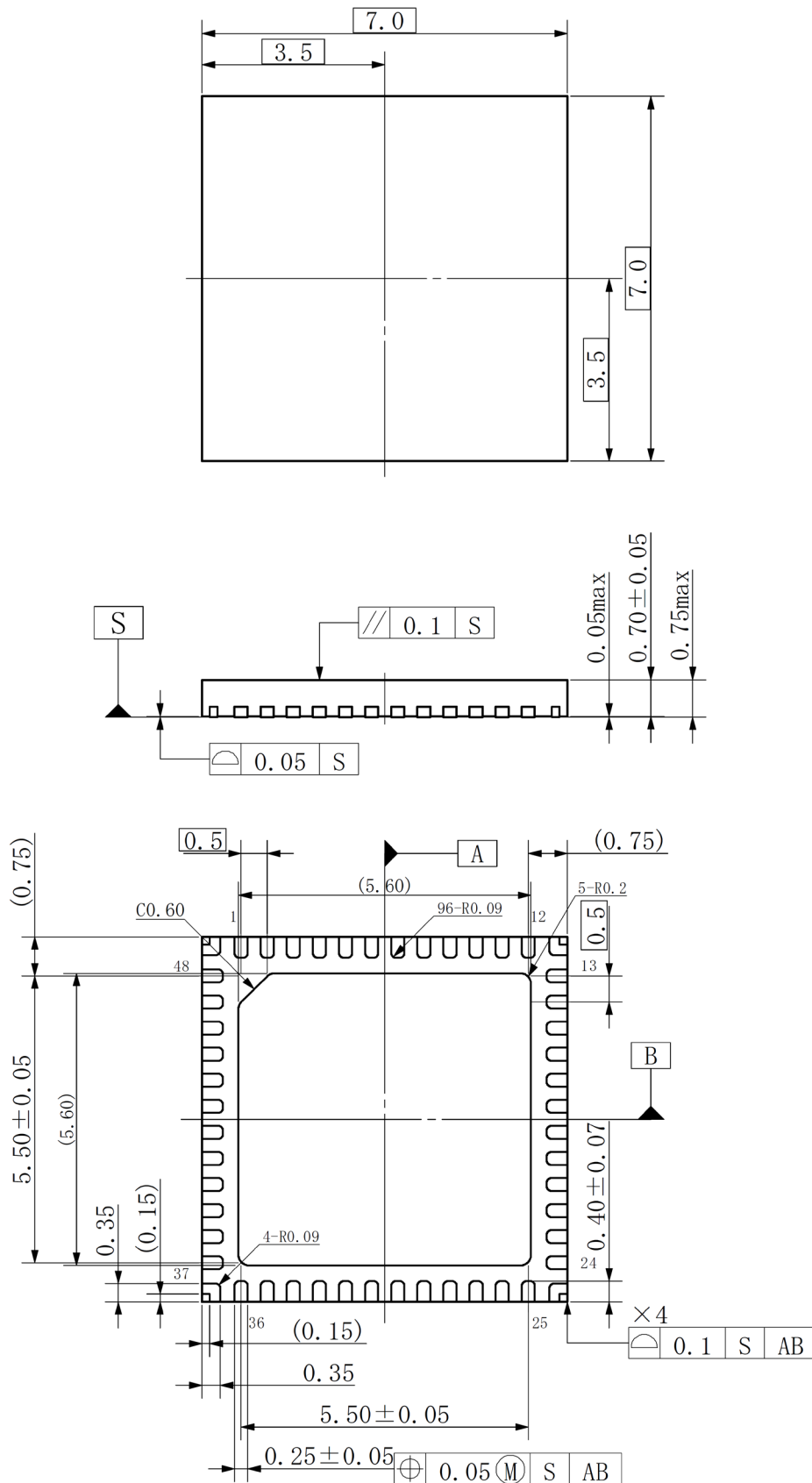

Weight: 0.10g (Typ.)

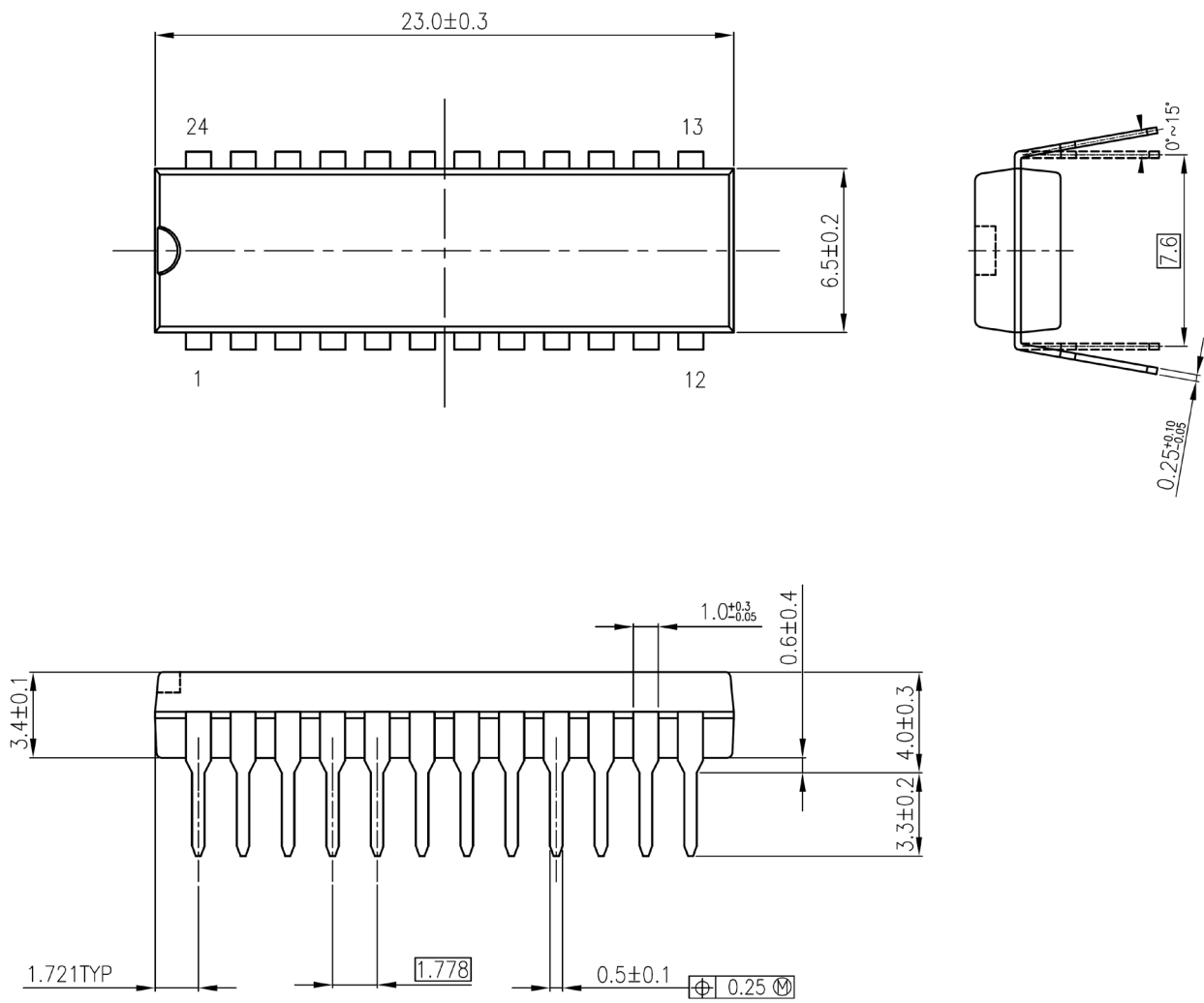

Weight: 1.3g (Typ.)

## Notes on Contents

### Block Diagrams

Some of the functional blocks, circuits, or constants in the block diagram may be omitted or simplified for explanatory purposes.

### Equivalent Circuits

The equivalent circuit diagrams may be simplified or some parts of them may be omitted for explanatory purposes.

### Timing Charts

Timing charts may be simplified for explanatory purposes.

### Application Circuits

The application circuits shown in this document are provided for reference purposes only. Thorough evaluation is required at the mass production design stage. Toshiba does not grant any license to any industrial property rights by providing these examples of application circuits.

### Test Circuits

Components in the test circuits are used only to obtain and confirm the device characteristics. These components and circuits are not guaranteed to prevent malfunction or failure from occurring in the application equipment.

## IC Usage Considerations

### Notes on handling of ICs

The absolute maximum ratings of a semiconductor device are a set of ratings that must not be exceeded, even for a moment. Do not exceed any of these ratings. Exceeding the rating(s) may cause device breakdown, damage or deterioration, and may result in injury by explosion or combustion.

Use an appropriate power supply fuse to ensure that a large current does not continuously flow in the case of over-current and/or IC failure. The IC will fully break down when used under conditions that exceed its absolute maximum ratings, when the wiring is routed improperly or when an abnormal pulse noise occurs from the wiring or load, causing a large current to continuously flow and the breakdown can lead to smoke or ignition. To minimize the effects of the flow of a large current in the case of breakdown, appropriate settings, such as fuse capacity, fusing time and insertion circuit location, are required.

If your design includes an inductive load such as a motor coil, incorporate a protection circuit into the design to prevent device malfunction or breakdown caused by the current resulting from the inrush current at power ON or the negative current resulting from the back electromotive force at power OFF. IC breakdown may cause injury, smoke or ignition. Use a stable power supply with ICs with built-in protection functions. If the power supply is unstable, the protection function may not operate, causing IC breakdown. IC breakdown may cause injury, smoke or ignition.

Do not insert devices in the wrong orientation or incorrectly. Make sure that the positive and negative terminals of power supplies are connected properly. Otherwise, the current or power consumption may exceed the absolute maximum rating, and exceeding the rating(s) may cause device breakdown, damage or deterioration, and may result in injury by explosion or combustion. In addition, do not use any device that has been inserted incorrectly.

Please take extra care when selecting external components (such as power amps and regulators) or external devices (for instance, speakers). When large amounts of leak current occurs from capacitors, the DC output level may increase. If the output is connected to devices such as speakers with low resist voltage, overcurrent or IC failure may cause smoke or ignition. (The over-current may cause smoke or ignition from the IC itself.) In particular, please pay attention when using a Bridge Tied Load (BTL) connection-type IC that inputs output DC voltage to a speaker directly.



## Points to remember on handling of ICs

### Over current detection circuit

Over current detection circuits (referred to as current limiter circuits) do not necessarily protect ICs under all circumstances. If the Over current detection circuits operate against the over current, clear the over current status immediately.

Depending on the method of use and usage conditions, such as exceeding absolute maximum ratings can cause the over current protection circuit to not operate properly or IC breakdown before operation. In addition, depending on the method of use and usage conditions, if over current continues to flow for a long time after operation, the IC may generate heat resulting in breakdown.

### Thermal Shutdown Circuit

Thermal shutdown circuits do not necessarily protect ICs under all circumstances. If the thermal shutdown circuits operate against the over temperature, clear the heat generation status immediately.

Depending on the method of use and usage conditions, such as exceeding absolute maximum ratings can cause the thermal shutdown circuit to not operate properly or IC breakdown before operation.

### Heat Radiation Design

In using an IC with large current flow such as power amp, regulator or driver, please design the device so that heat is appropriately radiated, not to exceed the specified junction temperature ( $T_j$ ) at any time and condition. These ICs generate heat even during normal use. An inadequate IC heat radiation design can lead to decrease in IC life, deterioration of IC characteristics or IC breakdown. In addition, please design the device taking into consideration the effect of IC heat radiation with peripheral components.

### Back-EMF

When a motor rotates in the reverse direction, stops or slows down abruptly, a current flow back to the motor's power supply due to the effect of back-EMF. If the current sink capability of the power supply is small, the device's motor power supply and output pins might be exposed to conditions beyond maximum ratings. To avoid this problem, take the effect of back-EMF into consideration in system design.

## RESTRICTIONS ON PRODUCT USE

- Toshiba Corporation, and its subsidiaries and affiliates (collectively "TOSHIBA"), reserve the right to make changes to the information in this document, and related hardware, software and systems (collectively "Product") without notice.
- This document and any information herein may not be reproduced without prior written permission from TOSHIBA. Even with TOSHIBA's written permission, reproduction is permissible only if reproduction is without alteration/omission.
- Though TOSHIBA works continually to improve Product's quality and reliability, Product can malfunction or fail. Customers are responsible for complying with safety standards and for providing adequate designs and safeguards for their hardware, software and systems which minimize risk and avoid situations in which a malfunction or failure of Product could cause loss of human life, bodily injury or damage to property, including data loss or corruption. Before customers use the Product, create designs including the Product, or incorporate the Product into their own applications, customers must also refer to and comply with (a) the latest versions of all relevant TOSHIBA information, including without limitation, this document, the specifications, the data sheets and application notes for Product and the precautions and conditions set forth in the "TOSHIBA Semiconductor Reliability Handbook" and (b) the instructions for the application with which the Product will be used with or for. Customers are solely responsible for all aspects of their own product design or applications, including but not limited to (a) determining the appropriateness of the use of this Product in such design or applications; (b) evaluating and determining the applicability of any information contained in this document, or in charts, diagrams, programs, algorithms, sample application circuits, or any other referenced documents; and (c) validating all operating parameters for such designs and applications. **TOSHIBA ASSUMES NO LIABILITY FOR CUSTOMERS' PRODUCT DESIGN OR APPLICATIONS.**
- **PRODUCT IS NEITHER INTENDED NOR WARRANTED FOR USE IN EQUIPMENTS OR SYSTEMS THAT REQUIRE EXTRAORDINARILY HIGH LEVELS OF QUALITY AND/OR RELIABILITY, AND/OR A MALFUNCTION OR FAILURE OF WHICH MAY CAUSE LOSS OF HUMAN LIFE, BODILY INJURY, SERIOUS PROPERTY DAMAGE AND/OR SERIOUS PUBLIC IMPACT ("UNINTENDED USE").** Except for specific applications as expressly stated in this document, Unintended Use includes, without limitation, equipment used in nuclear facilities, equipment used in the aerospace industry, medical equipment, equipment used for automobiles, trains, ships and other transportation, traffic signaling equipment, equipment used to control combustions or explosions, safety devices, elevators and escalators, devices related to electric power, and equipment used in finance-related fields. **IF YOU USE PRODUCT FOR UNINTENDED USE, TOSHIBA ASSUMES NO LIABILITY FOR PRODUCT.** For details, please contact your TOSHIBA sales representative.
- Do not disassemble, analyze, reverse-engineer, alter, modify, translate or copy Product, whether in whole or in part.
- Product shall not be used for or incorporated into any products or systems whose manufacture, use, or sale is prohibited under any applicable laws or regulations.
- The information contained herein is presented only as guidance for Product use. No responsibility is assumed by TOSHIBA for any infringement of patents or any other intellectual property rights of third parties that may result from the use of Product. No license to any intellectual property right is granted by this document, whether express or implied, by estoppel or otherwise.
- **ABSENT A WRITTEN SIGNED AGREEMENT, EXCEPT AS PROVIDED IN THE RELEVANT TERMS AND CONDITIONS OF SALE FOR PRODUCT, AND TO THE MAXIMUM EXTENT ALLOWABLE BY LAW, TOSHIBA (1) ASSUMES NO LIABILITY WHATSOEVER, INCLUDING WITHOUT LIMITATION, INDIRECT, CONSEQUENTIAL, SPECIAL, OR INCIDENTAL DAMAGES OR LOSS, INCLUDING WITHOUT LIMITATION, LOSS OF PROFITS, LOSS OF OPPORTUNITIES, BUSINESS INTERRUPTION AND LOSS OF DATA, AND (2) DISCLAIMS ANY AND ALL EXPRESS OR IMPLIED WARRANTIES AND CONDITIONS RELATED TO SALE, USE OF PRODUCT, OR INFORMATION, INCLUDING WARRANTIES OR CONDITIONS OF MERCHANTABILITY, FITNESS FOR A PARTICULAR PURPOSE, ACCURACY OF INFORMATION, OR NONINFRINGEMENT.**
- Do not use or otherwise make available Product or related software or technology for any military purposes, including without limitation, for the design, development, use, stockpiling or manufacturing of nuclear, chemical, or biological weapons or missile technology products (mass destruction weapons). Product and related software and technology may be controlled under the applicable export laws and regulations including, without limitation, the Japanese Foreign Exchange and Foreign Trade Law and the U.S. Export Administration Regulations. Export and re-export of Product or related software or technology are strictly prohibited except in compliance with all applicable export laws and regulations.
- Please contact your TOSHIBA sales representative for details as to environmental matters such as the RoHS compatibility of Product. Please use Product in compliance with all applicable laws and regulations that regulate the inclusion or use of controlled substances, including without limitation, the EU RoHS Directive. **TOSHIBA ASSUMES NO LIABILITY FOR DAMAGES OR LOSSES OCCURRING AS A RESULT OF NONCOMPLIANCE WITH APPLICABLE LAWS AND REGULATIONS.**

# Mouser Electronics

Authorized Distributor

Click to View Pricing, Inventory, Delivery & Lifecycle Information:

[Toshiba:](#)

[TB67H410FTG,EL](#)



Компания «ЭлектроПласт» предлагает заключение долгосрочных отношений при поставках импортных электронных компонентов на взаимовыгодных условиях!

Наши преимущества:

- Оперативные поставки широкого спектра электронных компонентов отечественного и импортного производства напрямую от производителей и с крупнейших мировых складов;
- Поставка более 17-ти миллионов наименований электронных компонентов;
- Поставка сложных, дефицитных, либо снятых с производства позиций;
- Оперативные сроки поставки под заказ (от 5 рабочих дней);
- Экспресс доставка в любую точку России;
- Техническая поддержка проекта, помощь в подборе аналогов, поставка прототипов;
- Система менеджмента качества сертифицирована по Международному стандарту ISO 9001;
- Лицензия ФСБ на осуществление работ с использованием сведений, составляющих государственную тайну;
- Поставка специализированных компонентов (Xilinx, Altera, Analog Devices, Intersil, Interpoint, Microsemi, Aeroflex, Peregrine, Syfer, Eurofarad, Texas Instrument, Miteq, Cobham, E2V, MA-COM, Hittite, Mini-Circuits, General Dynamics и др.);

Помимо этого, одним из направлений компании «ЭлектроПласт» является направление «Источники питания». Мы предлагаем Вам помощь Конструкторского отдела:

- Подбор оптимального решения, техническое обоснование при выборе компонента;
- Подбор аналогов;
- Консультации по применению компонента;
- Поставка образцов и прототипов;
- Техническая поддержка проекта;
- Защита от снятия компонента с производства.



#### Как с нами связаться

**Телефон:** 8 (812) 309 58 32 (многоканальный)

**Факс:** 8 (812) 320-02-42

**Электронная почта:** [org@eplast1.ru](mailto:org@eplast1.ru)

**Адрес:** 198099, г. Санкт-Петербург, ул. Калинина, дом 2, корпус 4, литера А.