

## ISL62882CEVAL2Z

Evaluation Board

AN1558  
Rev 0.00  
Apr 1, 2010

### Introduction

The ISL62882CEVAL2Z evaluation board demonstrates the performance of the ISL62882 multiphase synchronous-buck PWM  $V_{CORE}$  controller implementing Intel IMVP-6.5 protocol. The ISL62882 features Intersil's Robust Ripple Regulator ( $R^3$ ) technology. An on-board dynamic-load generator is included for evaluating the transient-load response. It applies a  $300\mu s$  pulse of approximately  $25m\Omega$  load across  $V_O$  and PGND.

Contents of this document include:

- Design Criteria
- Recommended Test Equipment
- Interface Connections
- Switch Descriptions
- DIP Switch Descriptions
- Jumper Descriptions
- Test Point Descriptions
- Evaluation Board Documentation
  - Bill of materials
  - Schematic
  - Silk-screen plots
  - Board layer plots

TABLE 1. DC/DC DESIGN CRITERIA

PARAMETER	VALUE	UNITS
$V_{IN}$	4.5 to 20	VDC
$V_O$	0 to 1.5	VDC
Full-load	60	ADC
PWM Frequency	300	kHz

### Recommended Equipment

- (QTY 1) Adjustable 25V, 10A Power Supply
- (QTY 1) Fixed 5V, 100mA Power Supply
- (QTY 1) Fixed 12V, 100mA Power Supply
- (QTY 1) Adjustable Constant Current Electronic Load
- (QTY 1) Digital Voltmeter
- (QTY 1) Four-Channel Oscilloscope

### Interface Connections

- $V_{IN}$ : Input Voltage to the Power Stage
  - J5:  $V_{IN}$  Positive Power Input
  - TP31:  $V_{IN}$  Positive Voltage Sense
  - J6:  $V_{IN}$  Return Power Input
  - TP32:  $V_{IN}$  Return Voltage Sense
- $V_O$ : Regulated Output Voltage
  - J11 and J12:  $V_O$  Positive Power Output
  - J13 and J14:  $V_O$  Return Power Output
- +5V: +5V Input Voltage
  - TP29: +5V Positive Input
  - TP30: +5V Return Input
- +12V: Input Voltage for the Dynamic-load Generator
  - TP3: 12V Positive Input
  - TP2: 12V Return Input

### Test Set-up

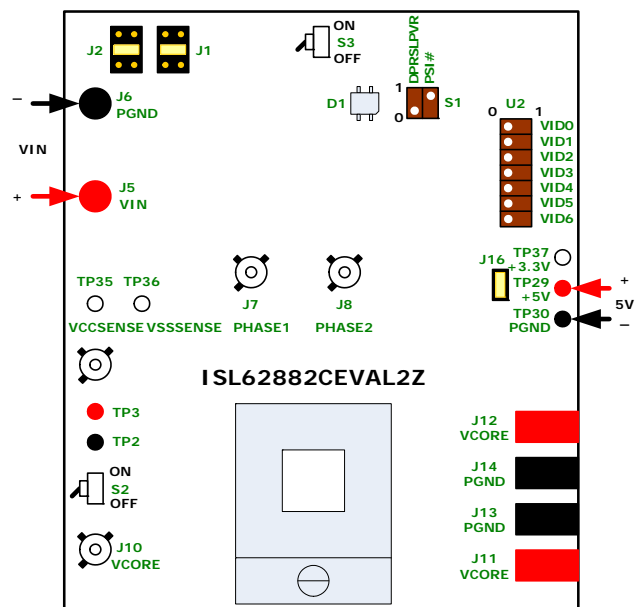

FIGURE 1. TEST SET-UP

### Switch Descriptions

- S3: Enable
  - OFF: Short the VR\_ON pin to GND (disable PWM)
  - ON: Allow the VR\_ON pin to pull-up to +5V (enable PWM)
- S5: Dynamic Load
  - OFF: On-board dynamic load disabled
  - ON: On-board dynamic load enabled

## DIP-Switch Descriptions

- S1: Set the control signals
  - S1.1: Set the DPRSLPVR signal
  - S1.2: Set the PSI# signal
- U2: Set the VID

## Jumper Descriptions

- J1: Set the ISEN2 pin configuration. ISEN2 can be connected to the power stage, tied to +5V, GND or left floating. Connect ISEN2 to the power stage when the ISL62882 is configured for 3- or 2-phase application. Tie ISEN2 to 5V when the ISL62882 is configured for 1-phase application.
- J2: Set the ISEN1 pin configuration. ISEN1 can be connected to the power stage, tied to +5V, GND or left floating. Connect ISEN1 to the power stage when the ISL62882 is configured for 3-, 2-phase application. Leave ISEN1 floating when the ISL62882 is configured for 1-phase application
- J16: If installed, the +5V rail supplies the +3.3V rail to the auxiliary circuit on the board. **DO NOT APPLY +3.3V TO TP37/TP30 WHILE J16 IS INSTALLED! IT'LL SHORT THE +5V AND THE +3.3V POWER SUPPLIES.** When measuring board efficiency, uninstall J16 and apply +3.3V to TP/37/TP30.

## Test-point Descriptions

- J7: Scope-probe socket for measuring PHASE1
- J8: Scope-probe socket for measuring PHASE2
- J9: Scope-probe socket for measuring PHASE3
- J10: Scope-probe socket for measuring  $V_O$
- J15: Scope-probe socket for measuring the current of the on-board transient-load emulator
- TP1: Monitor the on-board 1.2V power supply
- TP2: +12V power supply return input.
- TP3: +12V power supply positive input.
- TP4: Monitor the COMP pin
- TP5: Monitor the VW pin.

- TP6: Monitor the FB pin.
- TP7: Monitor the DPRSLPVR pin.
- TP8: Monitor the VR\_TT# pin.
- TP9: Monitor the PSI# pin.
- TP10: Monitor the ISEN3/FB2 pin.
- TP11: Monitor the ISEN2 pin.
- TP12: Input side of the compensator.
- TP13: Monitor the PGOOD pin.
- TP14: Monitor the VSEN pin.
- TP15: Monitor the ISEN1pin.
- TP16: Monitor the CLK\_EN# pin.
- TP17: Monitor the VR\_ON pin
- TP18: Monitor the RTN pin.
- TP19: Monitor the positive side of C82.
- TP20: Monitor the negative side of C82.
- TP21: Monitor the VID6 pin.
- TP22: Monitor the VID5 pin.
- TP23: Monitor the VID4 pin.
- TP24: Monitor the VID3 pin.
- TP25: Monitor the VID2 pin.
- TP26: Monitor the VID1 pin.
- TP27: Monitor the VID0 pin.
- TP28: Monitor the IMON pin.
- TP29: +5V power supply positive input.
- TP30: +5V power supply return input.
- TP31:  $V_{IN}$  positive voltage sense
- TP32:  $V_{IN}$  return voltage sense
- TP33: Monitor MOSFET Q3 gate signal
- TP34: Monitor MOSFET Q9 gate signal.
- TP35: Monitor the VCCSENSE pin of the CPU socket U4.
- TP36: Monitor the VSSSENSE pin of the CPU socket U4.
- TP37: +3.3V power supply positive input.
- TP38: Monitor the VTT1 rail of the CPU socket U4.
- TP39: Monitor the VTT2 rail of the CPU socket U4.

## Bill of Materials

REFERENCE	QTY	VALUE	PART NUMBER	DESCRIPTION	PACKAGE	VENDOR
C1	1	0.01 $\mu$ F	H1045-00103-16V10	Multilayer Cap, 16V, 10%	SM0603	Generic
C11	1	390pF	H1045-00391-16V10	Multilayer Cap, 16V, 10%	SM0603	Generic
C12, C14	2	330pF	H1045-00331-16V10	Multilayer Cap, 16V, 10%	SM0603	Generic
C13	1	1000pF	H1045-00102-16V10	Multilayer Cap, 16V, 10%	SM0603	Generic
C15	DNP					
C16, C2, C22, C23, C79	5	1 $\mu$ F	H1045-00105-16V20	Multilayer Cap, 16V, 20%	SM0603	Generic
C18	1	0.33 $\mu$ F	H1045-00334-16V10	Multilayer Cap, 16V, 10%	SM0603	Generic
C19		DNP				
C36, C37, C38, C8, C83	5	DNP				
C20, C45, C58	3	0.1 $\mu$ F	H1045-00104-16V10	Multilayer Cap, 16V, 10%	SM0603	Generic
C21	1	0.22 $\mu$ F	H1045-00224-16V10	Multilayer Cap, 16V, 10%	SM0603	Generic
C24, C25	2	56 $\mu$ F	25SP56M	Radial SP Series Cap, 25V, 20%	CASE-CC	Sanyo
C27, C28, C33, C34, C80	5	10 $\mu$ F	H1065-00106-25V20	Multilayer Cap, 25V, 20%	SM1206	Generic
C3	1	150pF	H1045-00151-16V10	Multilayer Cap, 16V, 10%	SM0603	Generic
C39, C52, C57	3	270 $\mu$ F	EEFSX0D271E4	POSCAP, 2V, 4.5m $\Omega$		Panasonic
C44		DNP				
C4	1	1000pF	H1045-00102-16V10	Multilayer Cap, 16V, 10%	SM0603	Generic
C40 to C43, C47 to C50, C53 to C56, C59 to C75, C78	30	10 $\mu$ F	GRM21BR61C106KE15L	Multilayer Cap, 6.3V, 20%	SM0805	Murata
C5	1	22pF	H1045-00220-16V10	Multilayer Cap, 16V, 10%	SM0603	Generic
C6	1	10pF	H1045-00100-16V10	Multilayer Cap, 16V, 10%	SM0603	Generic
C76, C77		DNP				
C26, C29, C32, C35, C7, C84, C85		DNP				
C9, C10, C17, C30, C31	5	0.22 $\mu$ F	H1045-00224-16V10	Multilayer Cap, 16V, 10%	SM0603	Generic
C81	1	1200pF	H1045-00122-16V10	Multilayer Cap, 16V, 10%	SM0603	Generic
C82	1	0.047 $\mu$ F	H1045-00473-16V10	Multilayer Cap, 16V, 10%	SM0603	Generic
D1	1		SSL-LXA3025IGC	3mmx2.5mm Surface Mount Red/Green LED	LED_3x2_5MM	Lumex
J1, J2	2		67996-272	2x3 Header, 2.54mm(0.100) Pitch	CONN2x3	Berg/FCI
J10	1		131-4353-00	Scope Probe Test Point PCB Mount	TEK131-4353-00	Tektronix
J15, J7, J8, J9	0	DNP				
J11 to J14	4		KPA8CTP	Wire Connector Lug	KPA8CTP	Burndy
J16	1		69190-202	2 Pin Header 2.54mm (0.100) Pitch	CONN2	Berg/FCI
J3, J4	2	DNP				

**Bill of Materials** (Continued)

REFERENCE	QTY	VALUE	PART NUMBER	DESCRIPTION	PACKAGE	VENDOR
J5	1		111-0702-001	Binding Post Red	111-07XX-001	Johnson-Comp
J6	1		111-0703-001	Binding Post Black	111-07XX-001	Johnson-Comp
L1, L2	2	0.36 $\mu$ H	MPCH1040LR36	Inductor, Inductance 20%, DCR 7%		Nec-Tokin
Q1, Q14	2		2N7002-7-F	N-Channel EMF Effect Transistor (Pb-Free)	SOT23	Fairchild
Q15	1		SUD50N03-07	N-Channel 30V (D-S) MOSFET	TO-252AA	Vishay
Q2, Q4, Q8, Q10	4		IRF7821	N-Channel Power MOSFET Power Switching	PWRPAK_SO8	IR
Q3, Q5, Q9, Q11	4		IRF7832	N-Channel Power MOSFET Power Switching	PWRPAK_SO8	IR
Q6, Q7, Q12, Q13		DNP				
R1	1	49.9	H2511-049R9-1/16W1	Thick Film Chip Resistor, 1%	SM0603	Generic
R10	1	562	H2511-05620-1/16W1	Thick Film Chip Resistor, 1%	SM0603	Generic
R102	1	49.9k	H2511-04992-1/16W1	Thick Film Chip Resistor, 1%	SM0603	Generic
R104, R105	2	249	H2511-02490-1/16W1	Thick Film Chip Resistor, 1%	SM0603	Generic
R106, R107	2	0.05	H2515-00R05-1W1-T	Thick Film Chip Resistor, 1%	SM2512	Generic
R108		DNP	H2511-00R00-1/16W1	Thick Film Chip Resistor, 1%	SM0603	Generic
R109	1	100	H2511-01000-1/16W1	Thick Film Chip Resistor, 1%	SM0603	Generic
R11	1	2.87k	H2511-02871-1/16W1	Thick Film Chip Resistor, 1%	SM0603	Generic
R12, R13, R15, R103	4	499	H2511-04990-1/16W1	Thick Film Chip Resistor, 1%	SM0603	Generic
R16	1	147k	H2511-01473-1/16W1	Thick Film Chip Resistor, 1%	SM0603	Generic
R17, R18	2	10	H2511-00100-1/16W1	Thick Film Chip Resistor, 1%	SM0603	Generic
R19, R23	2	1.91k	H2511-01911-1/16W1	Thick Film Chip Resistor, 1%	SM0603	Generic
R21, R28, R31, R36, R39, R43, R45, R46, R49, R51, R71, R72	12	10k	H2511-01002-1/16W1	Thick Film Chip Resistor, 1%	SM0603	Generic
R2, R8, R9, R26, R55, R74, R75, R76, R78, R81, R83, R84, R85, R86, R110		DNP				
R14, R20, R22, R24, R25, R27, R29, R32, R33, R34, R40, R52, R56, R57, R112	18	0	H2511-00R00-1/16W1	Thick Film Chip Resistor, 1%	SM0603	Generic
R30	1	1k	H2511-01001-1/16W1	Thick Film Chip Resistor, 1%	SM0603	Generic
R35	1	0	H2511-00R00-1/16W1	Thick Film Chip Resistor, 1%	SM0603	Generic
R37, R88, R90	3	1	H2511-01R00-1/16W1	Thick Film Chip Resistor, 1%	SM0603	Generic
R38	1	11k	H2511-01102-1/16W1	Thick Film Chip Resistor, 1%	SM0603	Generic
R4	1	DNP				
R41	1	2.61k	H2511-02611-1/16W1	Thick Film Chip Resistor, 1%	SM0603	Generic
R42	1	10k NTC	ERT-J1VR103J	Thermistor, 10k NTC	SM0603	Panasonic

**Bill of Materials** (Continued)

REFERENCE	QTY	VALUE	PART NUMBER	DESCRIPTION	PACKAGE	VENDOR
R44	1	DNP				
R47	1	DNP				
R48	1	0	H2511-00R00-1/16W1	Thick Film Chip Resistor, 1%	SM0603	Generic
R5, R80	2	100	H2511-01000-1/16W1	Thick Film Chip Resistor, 1%	SM0603	Generic
R50	1	9.31k	H2511-09311-1/16W1	Thick Film Chip Resistor, 1%	SM0603	Generic
R59, R60	2			Solder Joint (Heavy Duty)		
R6	1	8.06k	H2511-08061-1/16W1	Thick Film Chip Resistor, 1%	SM0603	Generic
R62, R64, R87, R89	4	0	H2511-00R00-1/16W1	Thick Film Chip Resistor, 1%	SM0603	Generic
R63, R65	2	3.65k	H2512-03651-1/16W1	Thick Film Chip Resistor, 1%	SM0805	Generic
R68, R69, R70, R77, R79, R82	6	DNP				
R7	1	412k	H2511-04123-1/16W1	Thick Film Chip Resistor, 1%	SM0603	Generic
R93, R94, R95, R99, R100, R101, R111, R113		DNP				
R96, R97	2			Solder Joint (Heavy Duty)		
S1	1		SD02HOSK	SD Series Low Profile Dip Switch	DIPSW-SMT-4	C&K
S2, S3	2		GT11MSCKE	SPDT On-None-On SMT Ultraminiature Toggle Switch	GT13MSCKE	C&K
S4	1		BAT54S	Schottky Barrier (Double) Diode	SOT23	Diodes
T2, T3, T29, T30	4		1514-2	Test Point Turret 0.15 Pad 0.1 Thole	TP-150C100P	Keystone
TP1, TP4 to TP28, TP31 to TP37	33		5002	Miniature White Test Point 0.100 Pad 0.040 Thole	MTP500X	Keystone
TP38, TP39	2	DNP				
U1	1		TLV431ASNT1	Low Volt Precision Adjustable Shunt Regulator	TSOP-5	On-Semi
U2	1		SD07HOSK	SD Series Low Profile Dip Switch	DIPSW-SMT-14	C&K
U3	1		ISL6208CBZ	Synchronous Rectified MOSFET Driver	SOIC8	Intersil
U4	1		rPGA989M	rPGA989 CPU Socket		Foxconn
U5	1		HIP2100IBZ	100V/2A Peak High Freq Half Bridge Driver (Pb-Free)	SOIC8	Intersil
U6	1		ISL62882HRZ	IMVP-6.5 PWM Controller	QFN-40	Intersil

# ISL62882CEVAL2Z Schematic

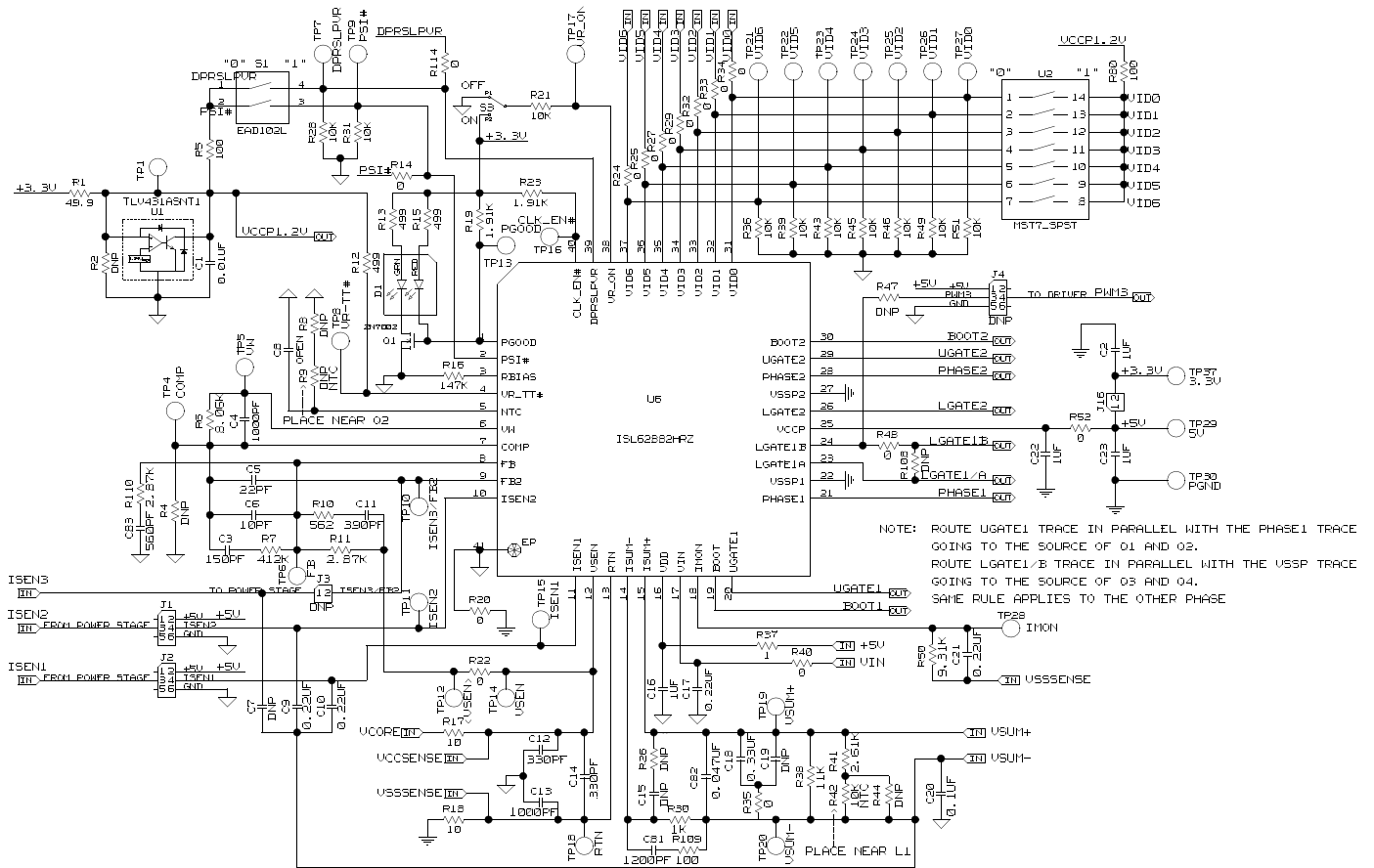

FIGURE 2. ISL62882CEVAL2Z SCHEMATICS, 1 OF 5

# ISL62882CEVAL2Z Schematic (Continued)

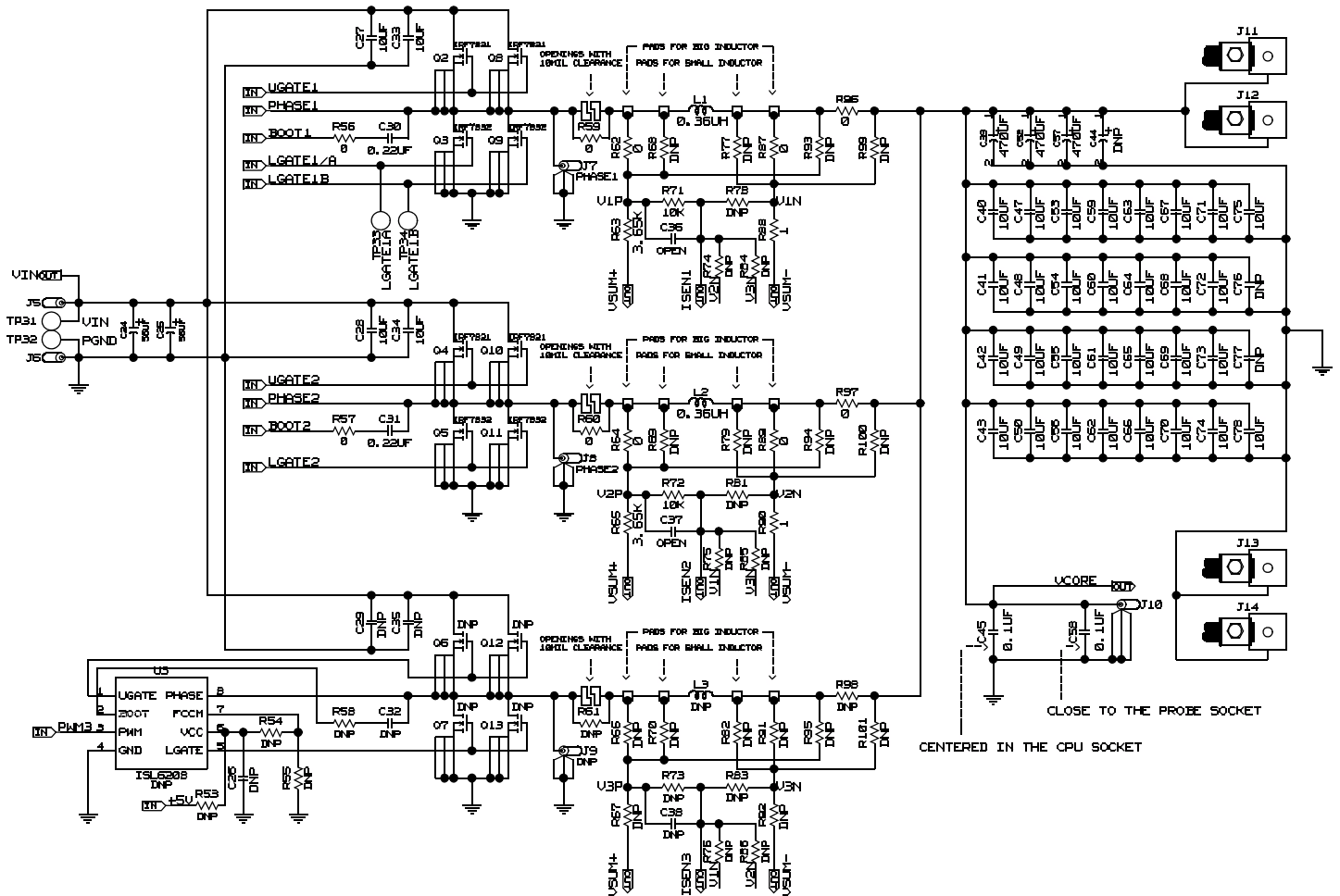

FIGURE 3. ISL62882CEVAL2Z SCHEMATICS, 2 OF 5

# ISL62882CEVAL2Z Schematic (Continued)

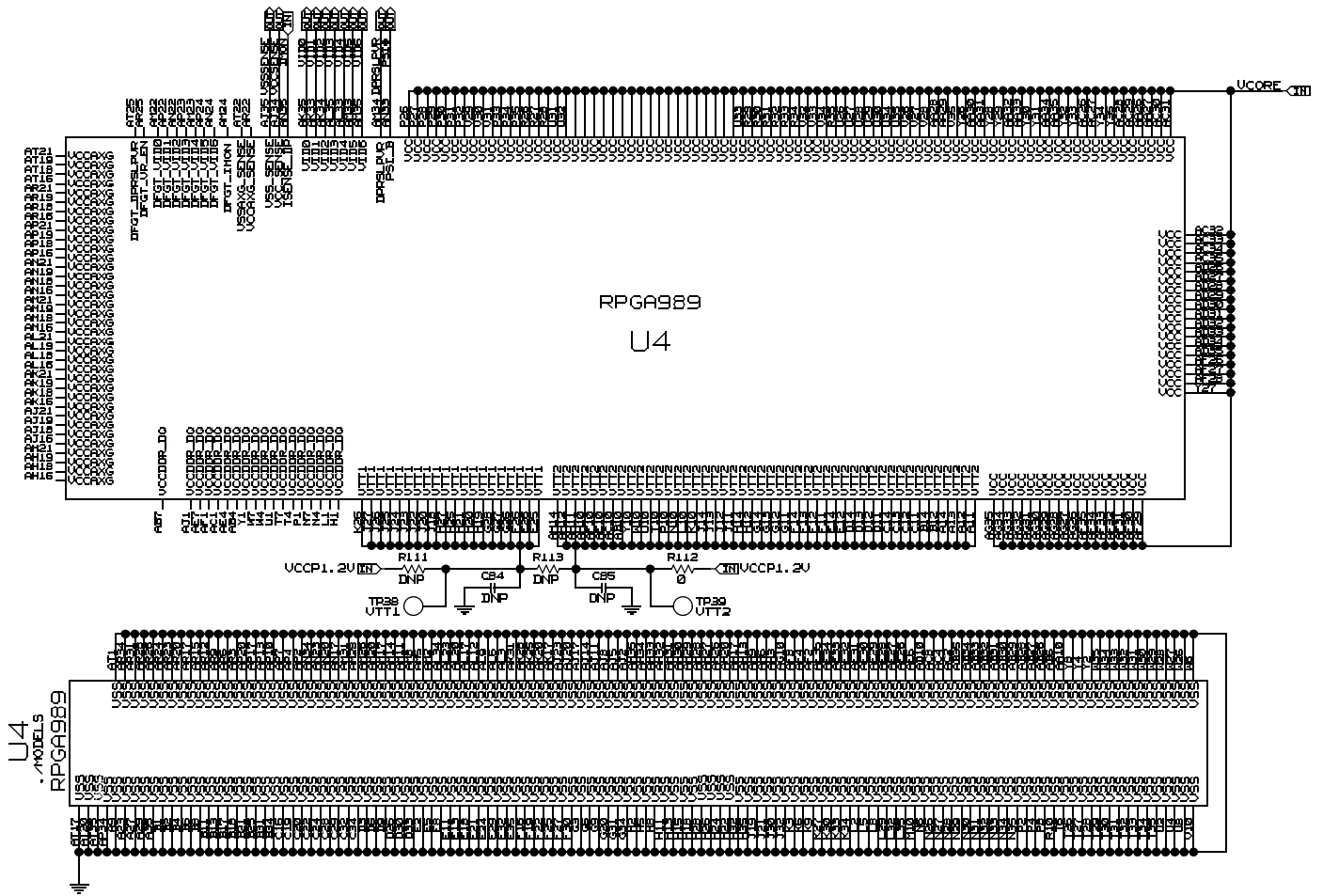

FIGURE 4. ISL62882CEVAL2Z SCHEMATICS, 3 OF 5

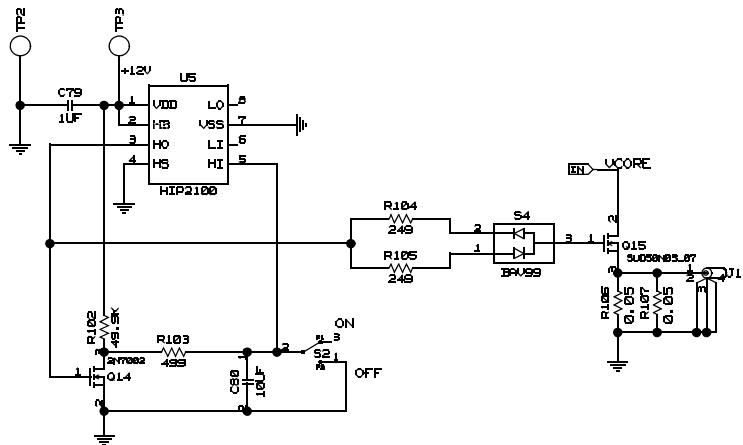

FIGURE 5. ISL62882CEVAL2Z SCHEMATICS, 4 OF 5



# ISL62882CEVAL2Z Schematic (Continued)

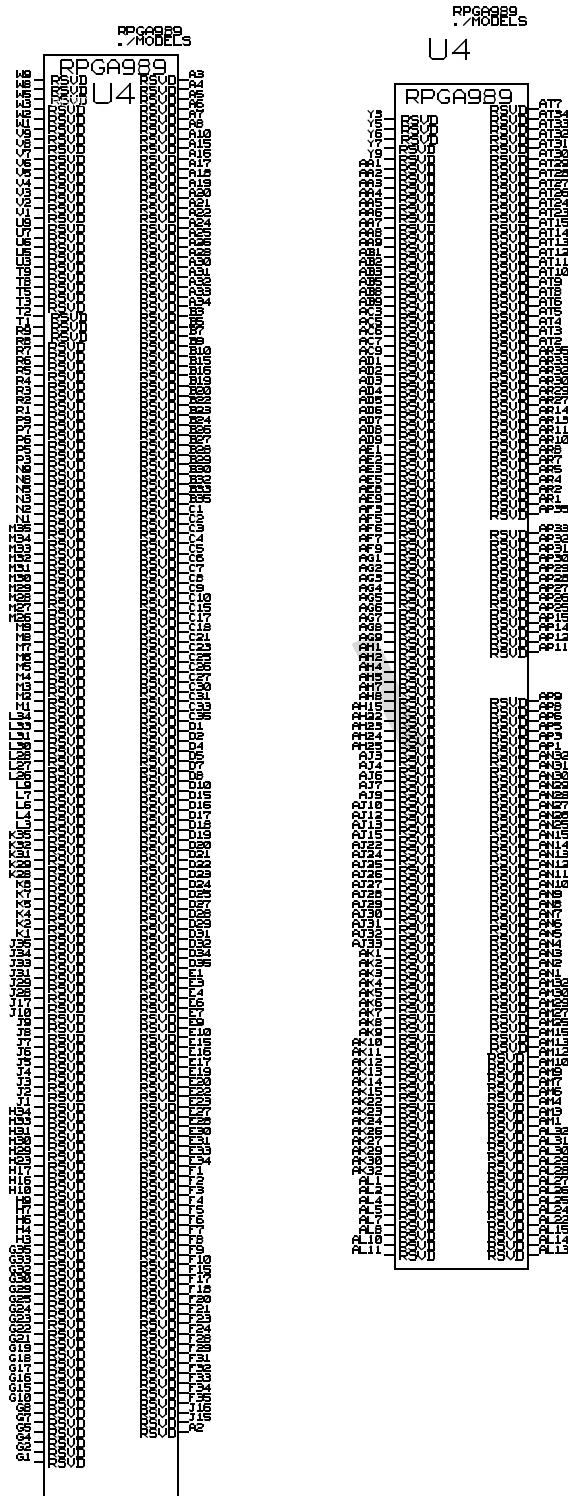

FIGURE 6. ISL62882CEVAL2Z SCHEMATICS, 5 OF 5

# ISL62882CEVAL2Z Evaluation Board Layout

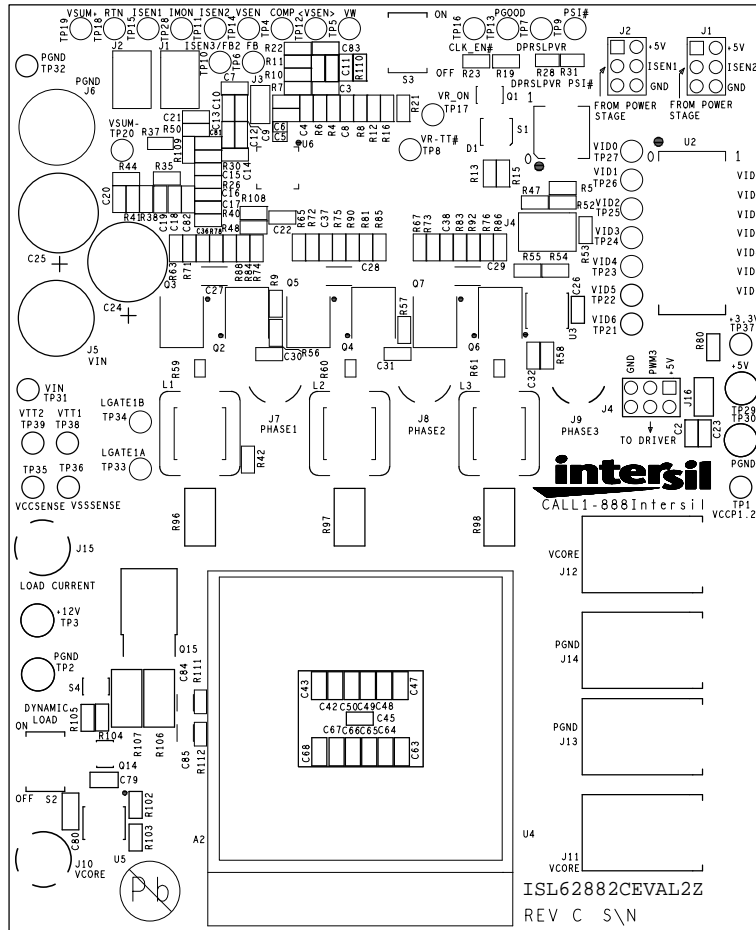

FIGURE 7. TOP SILKSCREEN

# ISL62882CEVAL2Z Evaluation Board Layout (Continued)

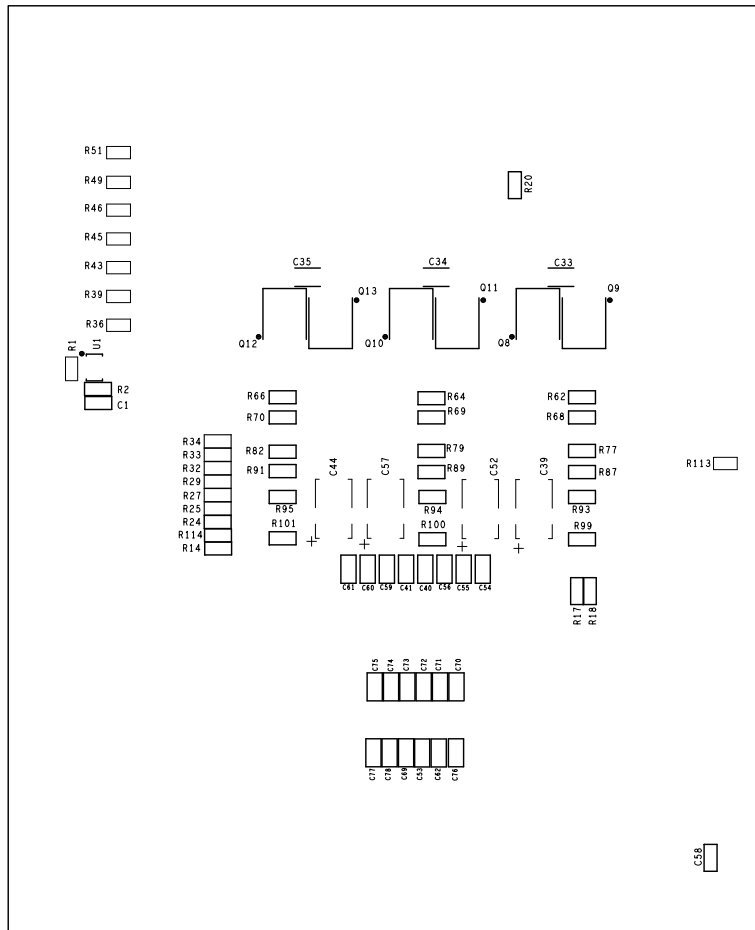

FIGURE 8. BOTTOM SILKSCREEN

# ISL62882CEVAL2Z Evaluation Board Layout (Continued)

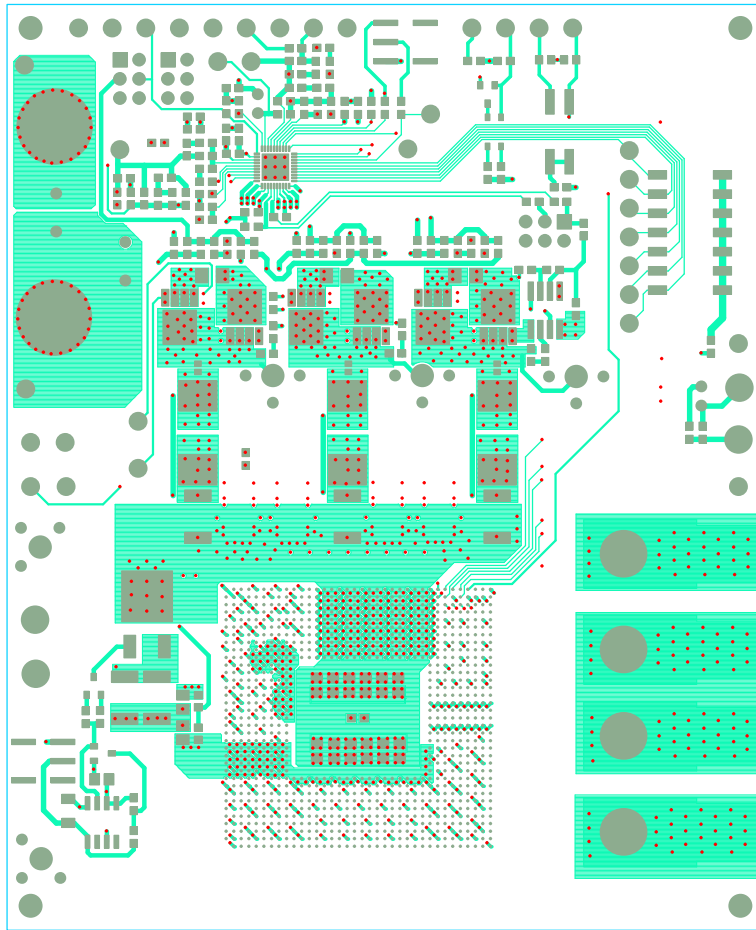

FIGURE 9. LAYER 1

## ISL62882CEVAL2Z Evaluation Board Layout (Continued)

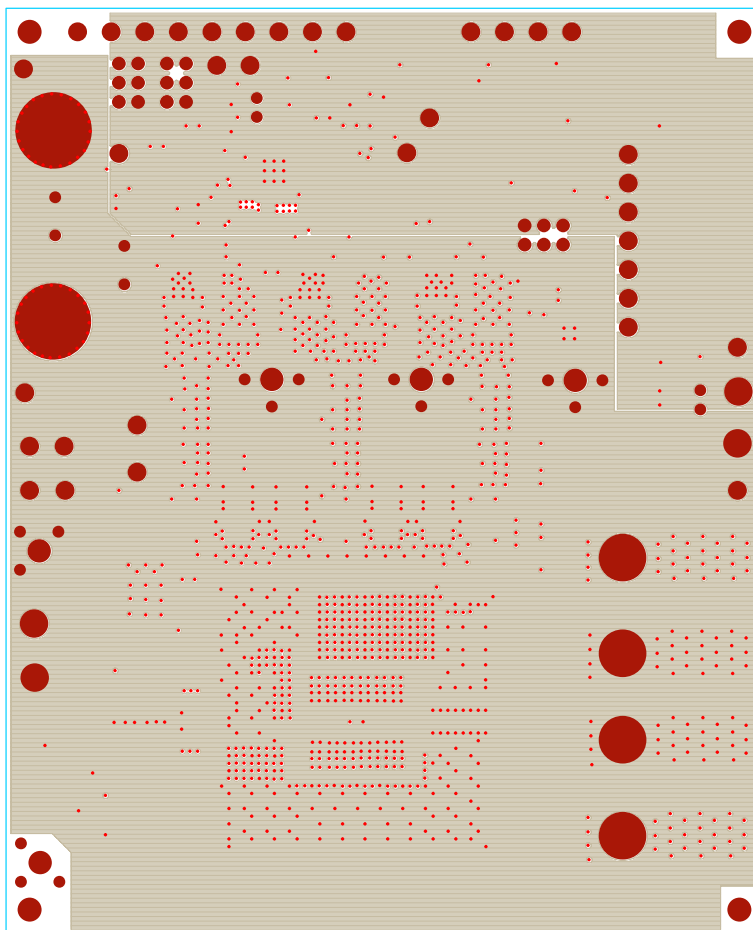

FIGURE 10. LAYER 2

# ISL62882CEVAL2Z Evaluation Board Layout (Continued)

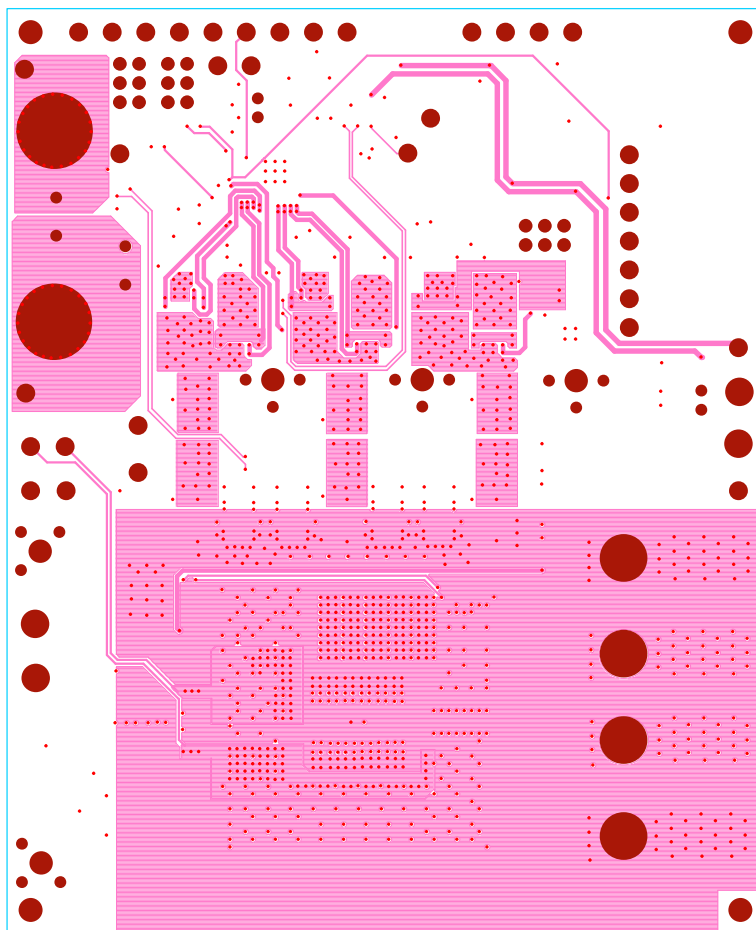

FIGURE 11. LAYER 3

# ISL62882CEVAL2Z Evaluation Board Layout (Continued)

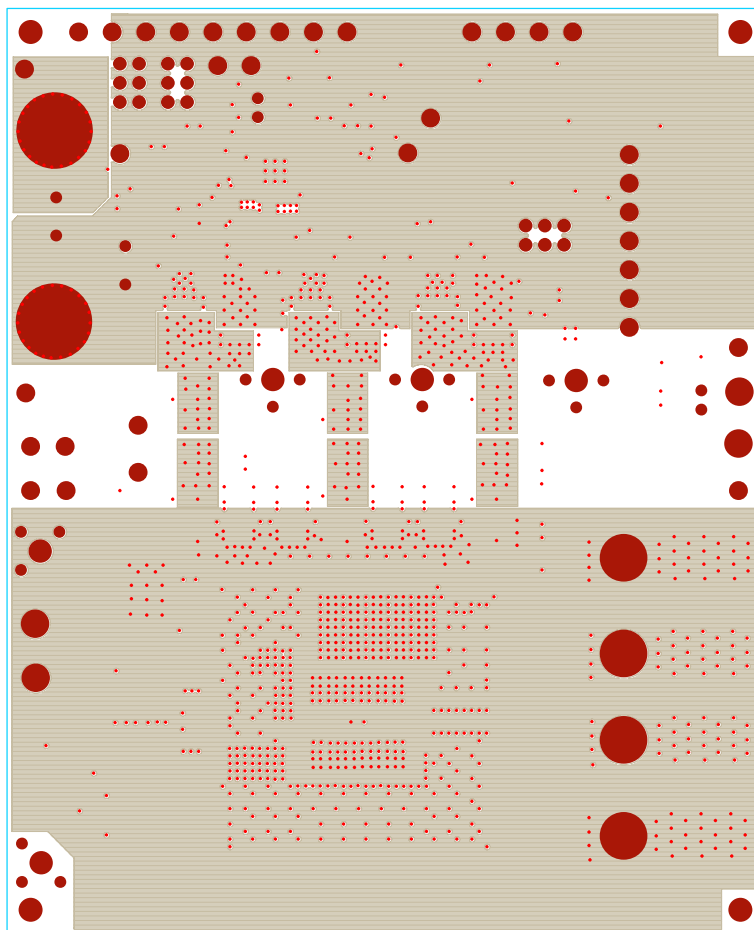

FIGURE 12. LAYER 4

# ISL62882CEVAL2Z Evaluation Board Layout (Continued)

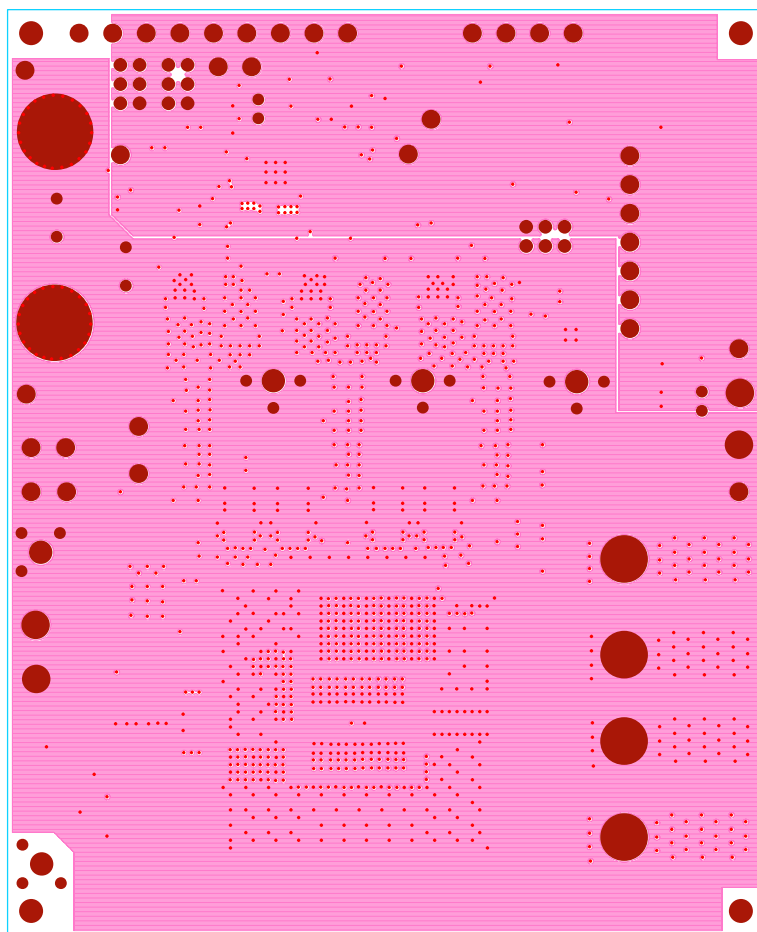

FIGURE 13. LAYER 5



# ISL62882CEVAL2Z Evaluation Board Layout (Continued)

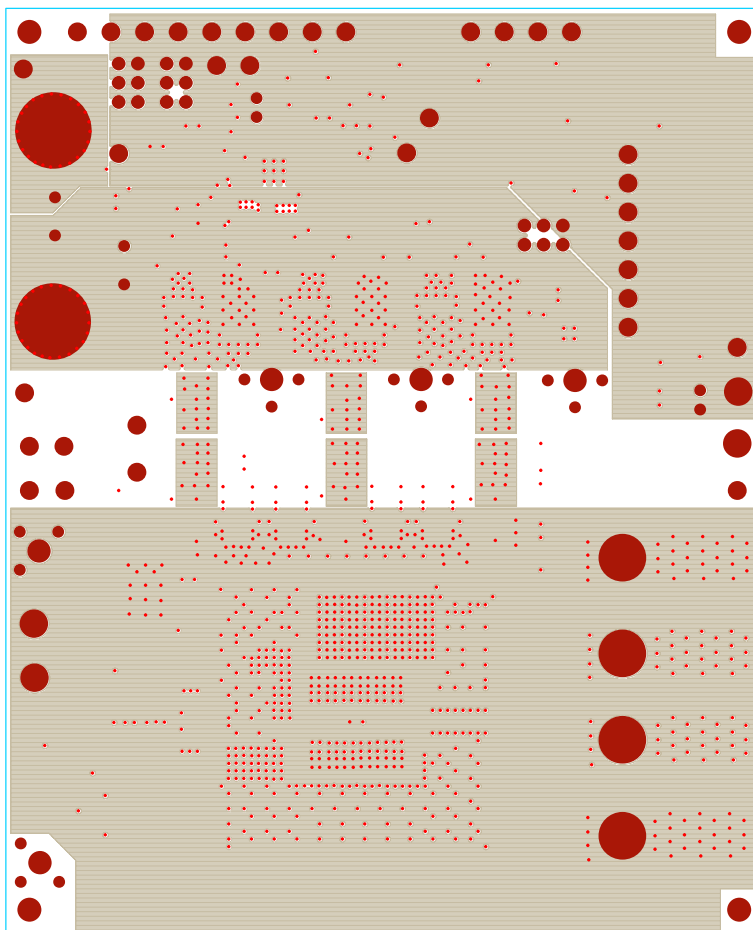

FIGURE 14. LAYER 6

# ISL62882CEVAL2Z Evaluation Board Layout (Continued)

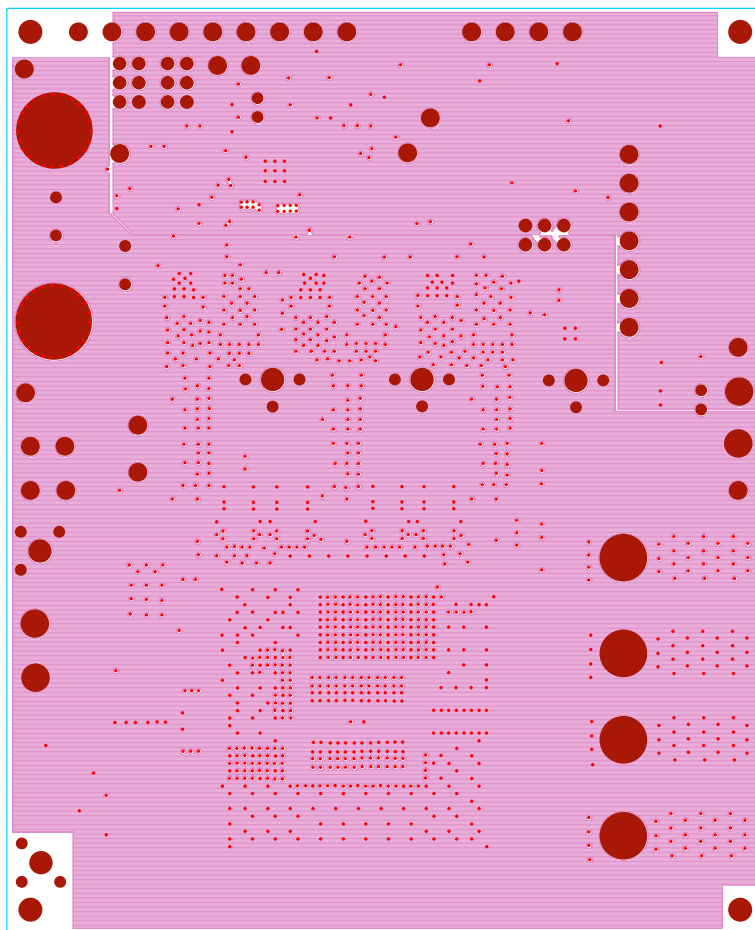

FIGURE 15. LAYER 7

# ISL62882CEVAL2Z Evaluation Board Layout (Continued)

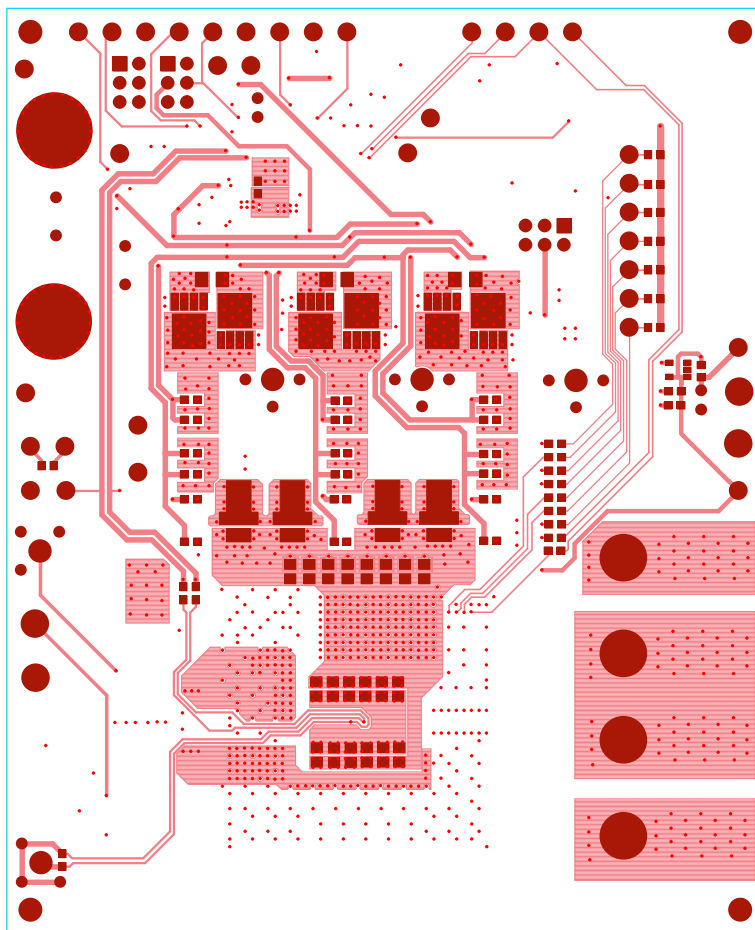

FIGURE 16. LAYER 8

## Notice

1. Descriptions of circuits, software and other related information in this document are provided only to illustrate the operation of semiconductor products and application examples. You are fully responsible for the incorporation or any other use of the circuits, software, and information in the design of your product or system. Renesas Electronics disclaims any and all liability for any losses and damages incurred by you or third parties arising from the use of these circuits, software, or information.
  2. Renesas Electronics hereby expressly disclaims any warranties against and liability for infringement or any other claims involving patents, copyrights, or other intellectual property rights of third parties, by or arising from the use of Renesas Electronics products or technical information described in this document, including but not limited to, the product data, drawings, charts, programs, algorithms, and application examples.
  3. No license, express, implied or otherwise, is granted hereby under any patents, copyrights or other intellectual property rights of Renesas Electronics or others.
  4. You shall not alter, modify, copy, or reverse engineer any Renesas Electronics product, whether in whole or in part. Renesas Electronics disclaims any and all liability for any losses or damages incurred by you or third parties arising from such alteration, modification, copying or reverse engineering.
  5. Renesas Electronics products are classified according to the following two quality grades: "Standard" and "High Quality". The intended applications for each Renesas Electronics product depends on the product's quality grade, as indicated below.  
"Standard": Computers; office equipment; communications equipment; test and measurement equipment; audio and visual equipment; home electronic appliances; machine tools; personal electronic equipment; industrial robots; etc.  
"High Quality": Transportation equipment (automobiles, trains, ships, etc.); traffic control (traffic lights); large-scale communication equipment; key financial terminal systems; safety control equipment; etc.  
Unless expressly designated as a high reliability product or a product for harsh environments in a Renesas Electronics data sheet or other Renesas Electronics document, Renesas Electronics products are not intended or authorized for use in products or systems that may pose a direct threat to human life or bodily injury (artificial life support devices or systems; surgical implantations; etc.), or may cause serious property damage (space system; undersea repeaters; nuclear power control systems; aircraft control systems; key plant systems; military equipment; etc.). Renesas Electronics disclaims any and all liability for any damages or losses incurred by you or any third parties arising from the use of any Renesas Electronics product that is inconsistent with any Renesas Electronics data sheet, user's manual or other Renesas Electronics document.
  6. When using Renesas Electronics products, refer to the latest product information (data sheets, user's manuals, application notes, "General Notes for Handling and Using Semiconductor Devices" in the reliability handbook, etc.), and ensure that usage conditions are within the ranges specified by Renesas Electronics with respect to maximum ratings, operating power supply voltage range, heat dissipation characteristics, installation, etc. Renesas Electronics disclaims any and all liability for any malfunctions, failure or accident arising out of the use of Renesas Electronics products outside of such specified ranges.
  7. Although Renesas Electronics endeavors to improve the quality and reliability of Renesas Electronics products, semiconductor products have specific characteristics, such as the occurrence of failure at a certain rate and malfunctions under certain use conditions. Unless designated as a high reliability product or a product for harsh environments in a Renesas Electronics data sheet or other Renesas Electronics document, Renesas Electronics products are not subject to radiation resistance design. You are responsible for implementing safety measures to guard against the possibility of bodily injury, injury or damage caused by fire, and/or danger to the public in the event of a failure or malfunction of Renesas Electronics products, such as safety design for hardware and software, including but not limited to redundancy, fire control and malfunction prevention, appropriate treatment for aging degradation or any other appropriate measures. Because the evaluation of microcomputer software alone is very difficult and impractical, you are responsible for evaluating the safety of the final products or systems manufactured by you.
  8. Please contact a Renesas Electronics sales office for details as to environmental matters such as the environmental compatibility of each Renesas Electronics product. You are responsible for carefully and sufficiently investigating applicable laws and regulations that regulate the inclusion or use of controlled substances, including without limitation, the EU RoHS Directive, and using Renesas Electronics products in compliance with all these applicable laws and regulations. Renesas Electronics disclaims any and all liability for damages or losses occurring as a result of your noncompliance with applicable laws and regulations.
  9. Renesas Electronics products and technologies shall not be used for or incorporated into any products or systems whose manufacture, use, or sale is prohibited under any applicable domestic or foreign laws or regulations. You shall comply with any applicable export control laws and regulations promulgated and administered by the governments of any countries asserting jurisdiction over the parties or transactions.
  10. It is the responsibility of the buyer or distributor of Renesas Electronics products, or any other party who distributes, disposes of, or otherwise sells or transfers the product to a third party, to notify such third party in advance of the contents and conditions set forth in this document.
  11. This document shall not be reprinted, reproduced or duplicated in any form, in whole or in part, without prior written consent of Renesas Electronics.
  12. Please contact a Renesas Electronics sales office if you have any questions regarding the information contained in this document or Renesas Electronics products.
- (Note 1) "Renesas Electronics" as used in this document means Renesas Electronics Corporation and also includes its directly or indirectly controlled subsidiaries.  
(Note 2) "Renesas Electronics product(s)" means any product developed or manufactured by or for Renesas Electronics.

(Rev.4.0-1 November 2017)



### SALES OFFICES

Renesas Electronics Corporation

<http://www.renesas.com>

Refer to "<http://www.renesas.com/>" for the latest and detailed information.

**Renesas Electronics America Inc.**  
1001 Murphy Ranch Road, Milpitas, CA 95035, U.S.A.  
Tel: +1-408-432-8888, Fax: +1-408-434-5351

**Renesas Electronics Canada Limited**  
9251 Yonge Street, Suite 8309 Richmond Hill, Ontario Canada L4C 9T3  
Tel: +1-905-237-2004

**Renesas Electronics Europe Limited**  
Dukes Meadow, Millboard Road, Bourne End, Buckinghamshire, SL8 5FH, U.K  
Tel: +44-1628-651-700, Fax: +44-1628-651-804

**Renesas Electronics Europe GmbH**  
Arcadiastrasse 10, 40472 Düsseldorf, Germany  
Tel: +49-211-6503-0, Fax: +49-211-6503-1327

**Renesas Electronics (China) Co., Ltd.**  
Room 1709 Quantum Plaza, No.27 ZhichunLu, Haidian District, Beijing, 100191 P. R. China  
Tel: +86-10-8235-1155, Fax: +86-10-8235-7679

**Renesas Electronics (Shanghai) Co., Ltd.**  
Unit 301, Tower A, Central Towers, 555 Langao Road, Putuo District, Shanghai, 200333 P. R. China  
Tel: +86-21-2226-0888, Fax: +86-21-2226-0999

**Renesas Electronics Hong Kong Limited**  
Unit 1601-1611, 16/F., Tower 2, Grand Century Place, 193 Prince Edward Road West, Mongkok, Kowloon, Hong Kong  
Tel: +852-2265-6688, Fax: +852-2886-9022

**Renesas Electronics Taiwan Co., Ltd.**  
13F, No. 363, Fu Shing North Road, Taipei 10543, Taiwan  
Tel: +886-2-8175-9600, Fax: +886-2-8175-9670

**Renesas Electronics Singapore Pte. Ltd.**  
80 Bendemeer Road, Unit #06-02 Hyflux Innovation Centre, Singapore 339949  
Tel: +65-6213-0200, Fax: +65-6213-0300

**Renesas Electronics Malaysia Sdn.Bhd.**  
Unit 1207, Block B, Menara Amcorp, Amcorp Trade Centre, No. 18, Jln Persiaran Barat, 46050 Petaling Jaya, Selangor Darul Ehsan, Malaysia  
Tel: +60-3-7955-9390, Fax: +60-3-7955-9510

**Renesas Electronics India Pvt. Ltd.**  
No.777C, 100 Feet Road, HAL 2nd Stage, Indiranagar, Bangalore 560 038, India  
Tel: +91-80-67208700, Fax: +91-80-67208777

**Renesas Electronics Korea Co., Ltd.**  
17F, KAMCO Yangjae Tower, 262, Gangnam-daero, Gangnam-gu, Seoul, 06265 Korea  
Tel: +82-2-558-3737, Fax: +82-2-558-5338



Компания «ЭлектроПласт» предлагает заключение долгосрочных отношений при поставках импортных электронных компонентов на взаимовыгодных условиях!

Наши преимущества:

- Оперативные поставки широкого спектра электронных компонентов отечественного и импортного производства напрямую от производителей и с крупнейших мировых складов;
- Поставка более 17-ти миллионов наименований электронных компонентов;
- Поставка сложных, дефицитных, либо снятых с производства позиций;
- Оперативные сроки поставки под заказ (от 5 рабочих дней);
- Экспресс доставка в любую точку России;
- Техническая поддержка проекта, помощь в подборе аналогов, поставка прототипов;
- Система менеджмента качества сертифицирована по Международному стандарту ISO 9001;
- Лицензия ФСБ на осуществление работ с использованием сведений, составляющих государственную тайну;
- Поставка специализированных компонентов (Xilinx, Altera, Analog Devices, Intersil, Interpoint, Microsemi, Aeroflex, Peregrine, Syfer, Eurofarad, Texas Instrument, Miteq, Cobham, E2V, MA-COM, Hittite, Mini-Circuits, General Dynamics и др.);

Помимо этого, одним из направлений компании «ЭлектроПласт» является направление «Источники питания». Мы предлагаем Вам помощь Конструкторского отдела:

- Подбор оптимального решения, техническое обоснование при выборе компонента;
- Подбор аналогов;
- Консультации по применению компонента;
- Поставка образцов и прототипов;
- Техническая поддержка проекта;
- Защита от снятия компонента с производства.



#### Как с нами связаться

**Телефон:** 8 (812) 309 58 32 (многоканальный)

**Факс:** 8 (812) 320-02-42

**Электронная почта:** [org@eplast1.ru](mailto:org@eplast1.ru)

**Адрес:** 198099, г. Санкт-Петербург, ул. Калинина, дом 2, корпус 4, литера А.