



SAFETY PRECAUTIONS AVOID INJURY

Safeguards are designed into this application equipment to protect operators and maintenance personnel from most hazards during equipment operation. However, certain safety precautions must be taken by the operator and repair personnel to avoid personal injury, as well as damage to the equipment. For best results, application equipment must be operated in a dry, dust-free environment. Do not operate equipment in a gaseous or hazardous environment.

Carefully observe the following safety precautions before and during operation of the equipment:

- ALWAYS wear appropriate ear protection.
- ALWAYS wear approved eye protection when operating powered equipment.
- ALWAYS keep guard(s) in place during normal operation.
- ALWAYS disconnect the tool from its power source when performing maintenance on the equipment.
- NEVER wear loose clothing or jewelry that may catch in moving parts of the application equipment.
- NEVER insert hands into installed application equipment.
- NEVER alter, modify, or misuse the application equipment.

TOOLING ASSISTANCE CENTER

CALL TOLL FREE 1-800-722-1111 (CONTINENTAL UNITED STATES AND PUERTO RICO ONLY)

The **Tooling Assistance Center** offers a means of providing technical assistance when required.

In addition, Field Service Specialists are available to provide assistance in the adjustment or repair of the application equipment when problems arise which your maintenance personnel are unable to correct.

INFORMATION REQUIRED WHEN CONTACTING THE TOOLING ASSISTANCE CENTER

When calling the Tooling Assistance Center regarding service to equipment, it is suggested that a person familiar with the device be present with a copy of the manual (and drawings) to receive instructions. Many difficulties can be avoided in this manner.

When calling the Tooling Assistance Center, be ready with the following information:

1. Customer name
2. Customer address
3. Person to contact (name, title, telephone number, and extension)
4. Person calling
5. Equipment number (and serial number if applicable)
6. Product part number (and serial number if applicable)
7. Urgency of request
8. Nature of problem
9. Description of inoperative component(s)
10. Additional information/comments that may be helpful

Read this document thoroughly before operating the machine. The performance of this machine will depend largely upon the intelligent use of this information contained in this document.

When reading this manual, pay particular attention to **DANGER**, **CAUTION**, and **NOTE** statements.

DANGER Denotes an imminent hazard which may result in moderate or severe injury.



CAUTION Denotes a condition which may result in product or equipment damage.



NOTE Highlights special or important information.



CAUTION Do NOT use the power unit as a crushing device or for anything other than a crimping machine for the specified product. Inappropriate use of the power unit could result in personnel injury OR damage to the power unit.



Always wear approved eye protection while operating the equipment.



Always wear approved hearing protection while operating the equipment.



Read and understand the entire manual.



Moving parts can crush and cut.



Do not operate the machine if the guards are removed.



Always disconnect the air and lockout the tool when not in use, when performing maintenance on the tool, or when clearing a jammed tool.

DANGER

There is a risk of whipping if a hose is not properly installed or becomes detached.

**NOTE**

Measurements are in metric units [followed by U.S. customary units in brackets]. Illustrations are for identification only and are not drawn to scale.

**DANGER**

The unit should ONLY be operated by trained personnel.

**DANGER**

If NOT using quick-disconnect fittings to connect the tool to the air supply, provide operators other means to easily disconnect the tool from the air supply.

**DANGER**

Stored gas or fluid MAY be a hazard.



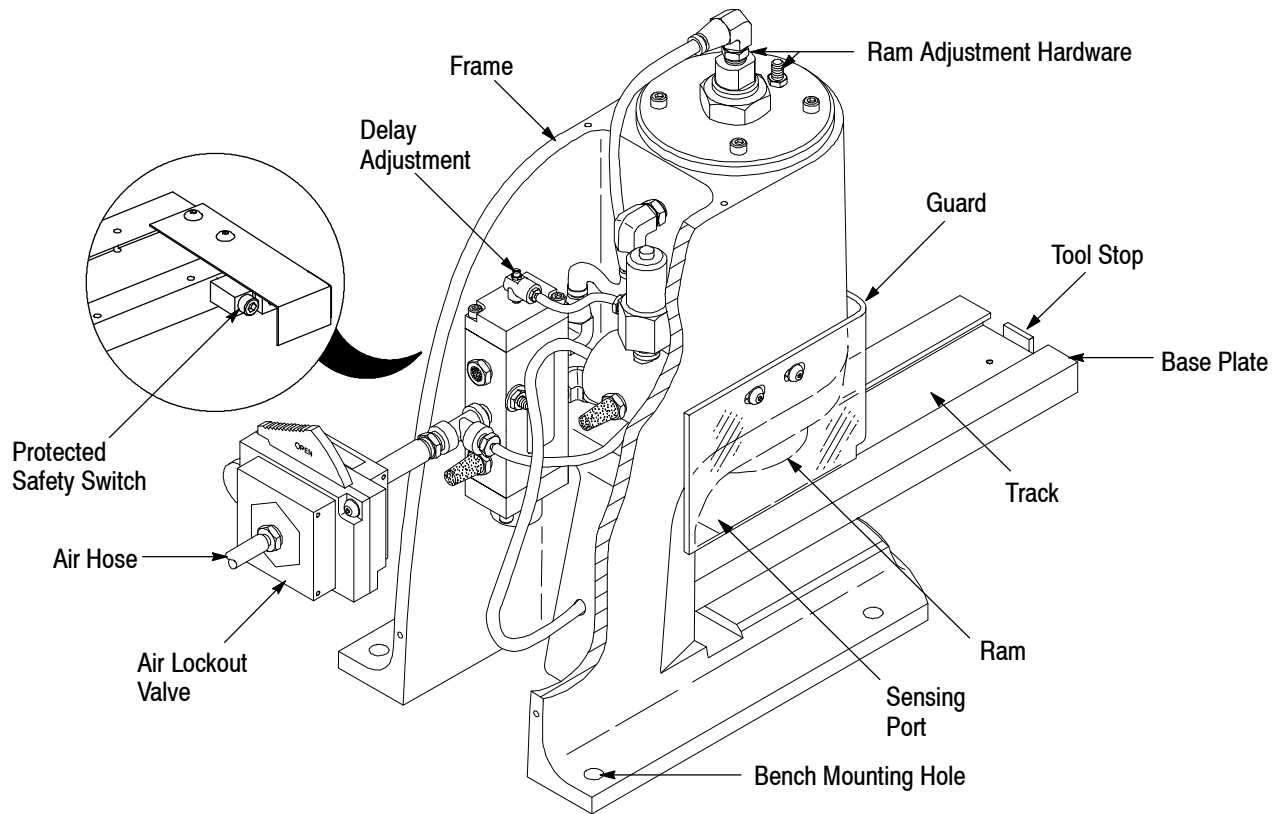

Figure 1

1. INTRODUCTION

This instruction sheet covers recommended procedures for frame setup, tooling assembly installation, and use and inspection of Pneumatic Auto-Cycle Unit 91112-3. Read these instructions thoroughly before using the pneumatic unit.

NOTE All numerical values in this instruction sheet are in metric units [with U.S. customary units in brackets]. Dimensions are in millimeters [and inches]. Figures are not drawn to scale.

Reasons for reissue of this instruction sheet are provided in Section 13, REVISION SUMMARY.

2. DESCRIPTION (Figure 1)

The pneumatic unit consists of a bench-mountable frame, a ram, a guard, a sensing port, a protected safety switch, an air hose, and a base plate and operates with a noise level of <92 dBA.

3. SETUP PROCEDURE

1. Secure the frame to a work bench to ensure stability during operation.

2. Connect the pneumatic unit to an air supply that will provide and maintain pressure of 550 to 620 kPa [80 to 90 psi] to the pneumatic unit.

NOTE The air line should be equipped with a filter that has an element with a maximum rating of 20 microns.

4. MACHINE SETUP (Figure 2)

Select an appropriate location for the machine. The location should be well lighted, and should have convenient and adequate air and power supplies.

1. Secure the machine to the bench with four 1/4-in. dia bolts or lag screws.
2. Blow air through the air hose to remove any foreign particles before attaching supply hose to the back of the machine.
3. Install air line filter, air pressure regulator, and lubricator (supplied by the customer) between the air supply and hose, as shown in Figure 3. The assembly must be as close as possible to the machine. Fill the air line lubricator with a good grade line lubricant (as recommended by the filter manufacturer). When machine is not in use, the air supply should be turned "OFF".

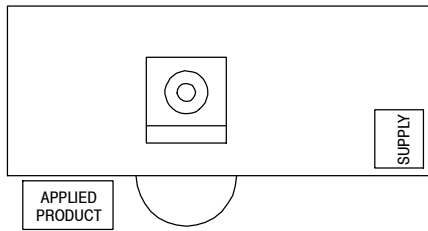

Materials Locations - Plan View

Figure 2 is a typical plan view to illustrate the convenience of handling materials afforded by the proper setup.

Figure 2

It is also recommended that quick-disconnect fittings are used to connect the tool to the air supply. If not using quick-disconnect fittings, provide a pneumatic lock-out on the air line that bleeds air after it is turned off.

5. Re-install the tool stop onto the base plate.
6. Re-install the guard and reconnect the air supply by unlocking and shifting the air lockout valve.

5. INSTALLING TOOLING ASSEMBLY (Figure 1)

The tooling assembly includes upper and lower tooling. Refer to the instruction sheet packaged with the tooling assembly for a description of components and specific orientation of tooling in the pneumatic unit.

Proceed as follows:

1. Disconnect the air supply by shifting the air lockout valve. Apply a lock or tag to this valve per applicable workplace safety procedures. Remove the guard.
2. Secure the appropriate upper tooling to the ram using the hardware included with the tooling assembly.
3. Remove the tool stop from the base plate.
4. Slide the lower tooling into the track on the base plate.

6. OPERATION

NOTE *Before attempting termination of any connectors, set the ram height as described in Paragraph 7.2, Ram Height Adjustment.*

1. Set up the lower tooling, and insert the connector and cable according to the instructions packaged with the tooling assembly.
2. To actuate the ram, slide the lower tooling to the rear of the base plate until the sensing port closes. This will actuate the protected safety switch and allow the ram to automatically cycle and terminate the cable to the connector.
3. When the ram has moved to the top of its motion, slide the lower tooling forward and remove the terminated connector.

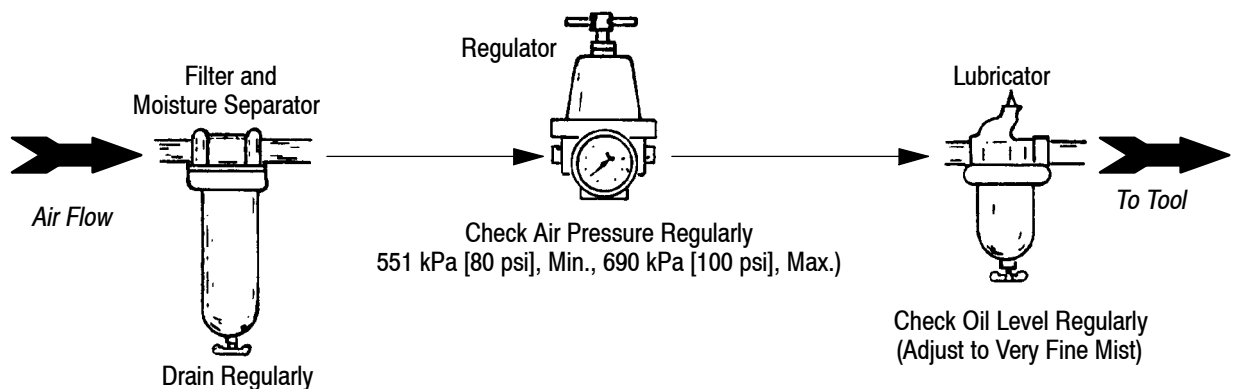

Figure 3

7. ADJUSTMENTS

7.1. Unit Cycle Time Adjustment

1. Remove the controls cover by removing the four retaining screws.
2. Set the ram bottoming time by turning the slotted adjustment screw at the top of the ram control valve, CLOCKWISE to increase bottoming time, COUNTER-CLOCKWISE to decrease bottoming time. Check the operation time by sliding the lower tooling to the rear of the base plate to actuate the pneumatic unit.
3. Re-install the controls cover.

7.2. Ram Height Adjustment (Figure 4)



Keep hands away from the ram if the guard is removed and the air is connected.

If an adjustment of the ram height is required to properly terminate connectors in the tooling installed in the pneumatic unit, refer to Figure 2 and proceed as follows:

1. Connect the air supply (ram will rise). Slide the lower tooling, without a connector loaded into it, into the pneumatic unit frame until it contacts the sensing port (ram will descend). With the ram fully DOWN, disconnect the air with the air lockout valve, as described in Section 4, Step 1.
2. Measure the distance between the bottom surface of the upper tooling and the surface of the lower tooling inserts. Determine the closed height dimension required according to the application specification for the connector being used and the instruction sheet for the tooling assembly being used.
3. If adjustment is required, record the dimension and direction (UP or DOWN) that the ram must be moved.

4. Loosen the down-travel threaded stud locknut. Turn the down-travel threaded stud locknut COUNTERCLOCKWISE several turns. Rotate the down-travel threaded stud CLOCKWISE to lower the ram, or COUNTERCLOCKWISE to raise the ram.

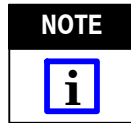

One full turn of the threaded stud equals 1.57 mm [.062 in.] of ram height movement.

5. After the height adjustment is made, tighten the threaded stud locknut.
6. Repeat Steps 1 and 2. If further adjustment is required, repeat Steps 3 through 5. Continue making adjustments until the proper height dimension is attained.

7. If the instruction sheet for the tooling assembly being used specifies an open height setting for the pneumatic unit, this may be accomplished in a similar fashion by adjusting the up-travel threaded stud (see Figure 2) CLOCKWISE to lower the ram open height, COUNTER-CLOCKWISE to raise the ram open height. Disconnect the air supply as described in Section 4, Step 1, while measuring and adjusting the ram height. Reconnect the air after each adjustment to make sure that the ram is in the full up position, then disconnect the air again for measurement.

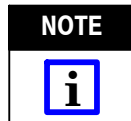

One full turn of the up-travel threaded stud is equal to approximately 1.27 mm [0.05 in.] of ram height movement.

8. After completing the ram height adjustment, tighten the threaded stud locknut.

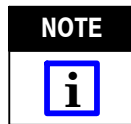

After the proper height adjustments are reached, replace all applicable guards and covers in their original positions with the proper attachment hardware.

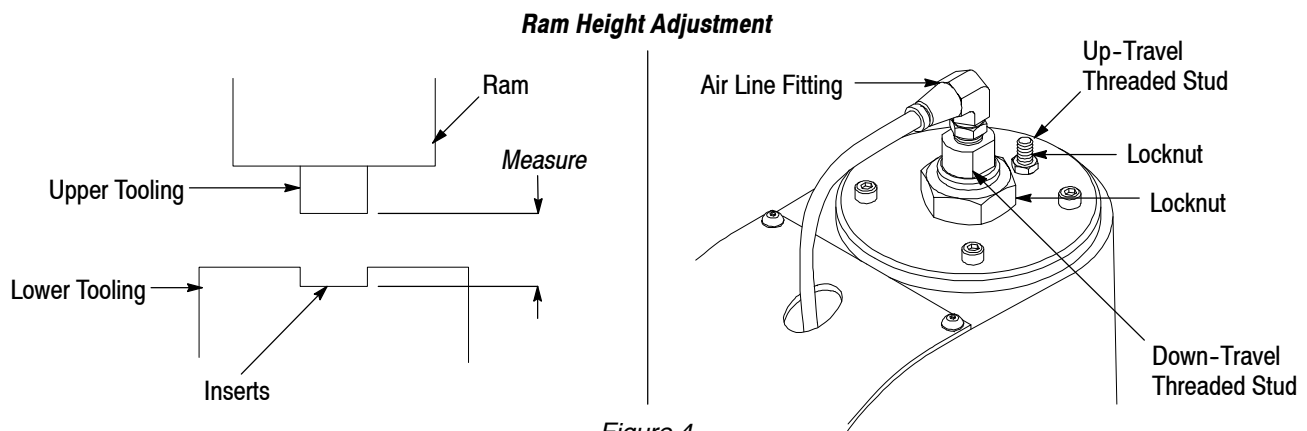

Figure 4

8. INSPECTION

The pneumatic unit should be inspected with the information provided in Figure 5. It is recommended that the unit be inspected immediately upon its arrival at your facility, and at regularly scheduled intervals, to ensure that the unit has not been damaged during handling.

9. PREVENTIVE MAINTENANCE

Preventive maintenance of the machine is limited to periodic cleaning, inspection, and lubrication. Depending on the amount of use, a regular maintenance program should be established and maintained, whether daily, weekly, or monthly. This will greatly reduce downtime for repairs and replacement of parts. When performing preventive maintenance, remove cover to gain access to the machine.



When performing preventive maintenance, MAKE SURE that the air supply is turned "OFF".

9.1. Cleaning

Prior to operation, or on a daily basis, perform the following:

1. Use a CLEAN, dry cloth to wipe the entire machine. Remove any evidence of dust or other contaminants.
2. Use a solvent or similar cleaning fluid to remove any evidence of oil or grease from areas not requiring lubrication, particularly in the "target area".
3. Use an approved-type air hose or vacuum to remove any chips or metal particles that may be in the machine.



Compressed air used for cleaning must be reduced to less than 207 kPa [30 psi], and effective chip guarding (including eye protection) must be worn.

9.2. Inspection

Perform the following inspection daily or prior to each time the machine is to be used.

1. Check to ensure all components of the machine are secure, and look for evidence of worn or broken parts.
2. Inspect the pneumatic system for loose connectors or leakage in the air lines. Repair and/or replace components as necessary.

3. Check the air supply system and follow the manufacturer's instructions for maintenance and care of the air supply filter/regulator/lubricator.

9.3. Lubrication

Because the bearing is an oilless-type bearing, no lubrication is necessary. However, the air supply should be lubricated, as recommended by the manufacturer, described in Section 4, Machine Setup.

The fluid level in the lubricator should be checked daily.



DO NOT allow any lubricants to enter the "target area". If this should happen, thoroughly clean the area immediately.

10. STORAGE

If the tool is not used, it must be stored by taking the following precautions:

1. Store the tool indoors.
2. Grease unpainted parts.
3. Protect this tool from knocks or stresses.
4. Protect the tool from high levels of humidity and from big temperature changes.
5. Prevent the tool from coming into contact with corrosive substances.

11. DECOMMISSIONING

In compliance with the regulations in force in the country where the tool is used, the user must make sure that waste produced during operation is correctly disposed of. Disposal of lubricants and parts removed must be carried out in compliance with the standards in force in the country where the tool is used.

12. REPLACEMENT AND REPAIR

Customer-replaceable parts are listed in Figure 5. Parts other than those listed should be replaced by TE Connectivity to ensure quality and reliability. Order replacement parts through your representative, or call 1-800-526-5142, or send a facsimile of your purchase order to 717-986-7605, or write to:

CUSTOMER SERVICE (038-035)
 TYCO ELECTRONICS CORPORATION
 PO BOX 3608
 HARRISBURG PA 17105-3608

For customer repair service, call 1-800-526-5136.

13. REVISION SUMMARY

Revisions to this instruction sheet include:

- Updated document to corporate requirements
- New logo

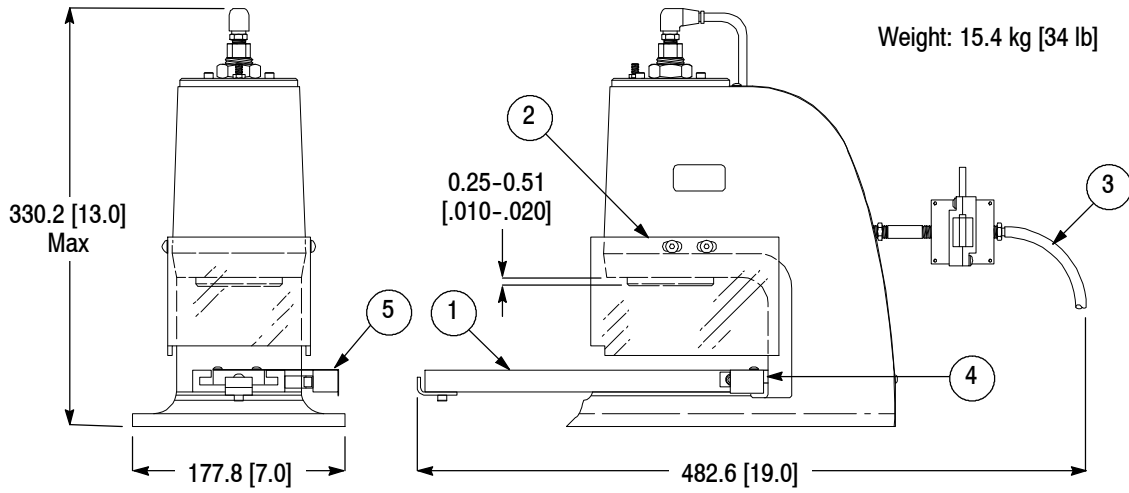

ITEM	PART NUMBER	DESCRIPTION	QTY PER UNIT
1	126328-4	SUB-ASSEMBLY, Base Plate	1
2	126424-1	KIT, Guard	1
3	38111	HOSE, Air	1
4	18917-1	PORT, Sensing	1
5	1583207-1	COVER, Switch	1

Figure 5



Компания «ЭлектроПласт» предлагает заключение долгосрочных отношений при поставках импортных электронных компонентов на взаимовыгодных условиях!

Наши преимущества:

- Оперативные поставки широкого спектра электронных компонентов отечественного и импортного производства напрямую от производителей и с крупнейших мировых складов;
- Поставка более 17-ти миллионов наименований электронных компонентов;
- Поставка сложных, дефицитных, либо снятых с производства позиций;
- Оперативные сроки поставки под заказ (от 5 рабочих дней);
- Экспресс доставка в любую точку России;
- Техническая поддержка проекта, помощь в подборе аналогов, поставка прототипов;
- Система менеджмента качества сертифицирована по Международному стандарту ISO 9001;
- Лицензия ФСБ на осуществление работ с использованием сведений, составляющих государственную тайну;
- Поставка специализированных компонентов (Xilinx, Altera, Analog Devices, Intersil, Interpoint, Microsemi, Aeroflex, Peregrine, Syfer, Eurofarad, Texas Instrument, Miteq, Cobham, E2V, MA-COM, Hittite, Mini-Circuits, General Dynamics и др.);

Помимо этого, одним из направлений компании «ЭлектроПласт» является направление «Источники питания». Мы предлагаем Вам помощь Конструкторского отдела:

- Подбор оптимального решения, техническое обоснование при выборе компонента;
- Подбор аналогов;
- Консультации по применению компонента;
- Поставка образцов и прототипов;
- Техническая поддержка проекта;
- Защита от снятия компонента с производства.



Как с нами связаться

Телефон: 8 (812) 309 58 32 (многоканальный)

Факс: 8 (812) 320-02-42

Электронная почта: org@eplast1.ru

Адрес: 198099, г. Санкт-Петербург, ул. Калинина, дом 2, корпус 4, литера А.