

# FIL SERIES

## Precision Filament Supply



The FIL Series is a non-isolated precision filament supply. This line of regulated DC-DC converters addresses the needs of the high precision and high stability power supply user. Designed and built utilizing a state-of-the-art power-conversion topology, these units feature surface-mount technology and encapsulation techniques that provide high reliability and low cost. The FIL Series supply allows users to properly operate the filament to maximize performance and extend its life. Typical applications for this series include precision filaments for mass spectrometry, electron beams, and test equipment.

- High precision and high stability
- 15PPM temperature coefficient
- 0 to 5VDC
- 0 to 3 Amps of current
- Maximum Iout capability down to 0 Volts
- Programmable voltage and current controls
- Indefinite output short-circuit protection
- Buffered output current & voltage monitors
- Excellent linearity & accuracy of control
- Current mode and voltage mode indicator
- Synchronizable

PARAMETER	CONDITIONS	MODELS	UNITS
<b>INPUT</b>		<b>ALL TYPES</b>	
Operating Range	All Conditions	+24 ± 10	VDC
Current	Full Load Output	900mA Typical	mA
<b>OUTPUT</b>		<b>ALL TYPES</b>	
Voltage Range	Nominal Input	0 to 5	VDC
DC Current Range	Nominal Input	0 to 3	Amps
Voltage Range	Derated	0 to 5.7	VDC
DC Current Range	Derated	0 to 3.3	Amps
Voltage Monitor Scaling	Full Load	10	VDC
Current Monitor Scaling	Full Load	10	VDC
<b>PROGRAMMING &amp; CONTROLS</b>		<b>ALL TYPES</b>	
Input Impedance	Nominal Input	+ Output Models 10MΩ to GND	MΩ
Adjust Resistance	Typical Potentiometer Values	10K to 100K (Pot across Vref. & Signal GND, Wiper to Adjust)	Ω
Adjust Voltage	Referenced to signal ground	0 to +10 VDC	VDC
Accuracy	In current control	±0.1%	Amps
Offset	Voltage control	0.04%	VDC
Offset	Current control	0.001%	Amps
Output Voltage	T=+25°C, Initial Value	+10.0V ± 0.05%	VDC
Enable/Disable		0 to +0.5 Disable, +2.4 to 10 Enable (Default = Enable)	VDC
<b>ENVIRONMENTAL</b>		<b>ALL TYPES</b>	
Operating	Full Load, Max Eout, Case Temp.	+10 to +45	°C
Coefficient	Over the Specified Temperature	≤ 15	PPM/°C
Thermal Shock	Mil-Std 810, Method 503-4, Proc. II	-40 to +65	°C
Storage	Non-Operating, Case Temp.	-55 to +85	°C
Altitude	Standard Package, All Conditions	Sea Level through Vacuum	-
Shock	Mil-Std-810, Method 516.5, Proc. IV	20	G's
Vibration	Mil-Std-810, Method 514.5, Fig.514.5C-3	10	G's

Specifications subject to change without notice.



Making High Voltage Easier!®

Higher Service, Higher Performance, Higher Reliability  
©2011, UltraVolt Inc. All rights reserved.

# FIL SERIES

## Precision Filament Supply

### INPUT/OUTPUT WIRING DIAGRAM

The filament power supply load should be connected between the FIL(+) output and the FIL(-) output, load current should not flow through the center tap, which is common with the (+)24V return. The FIL(-) or FIL(+) outputs should not be grounded.

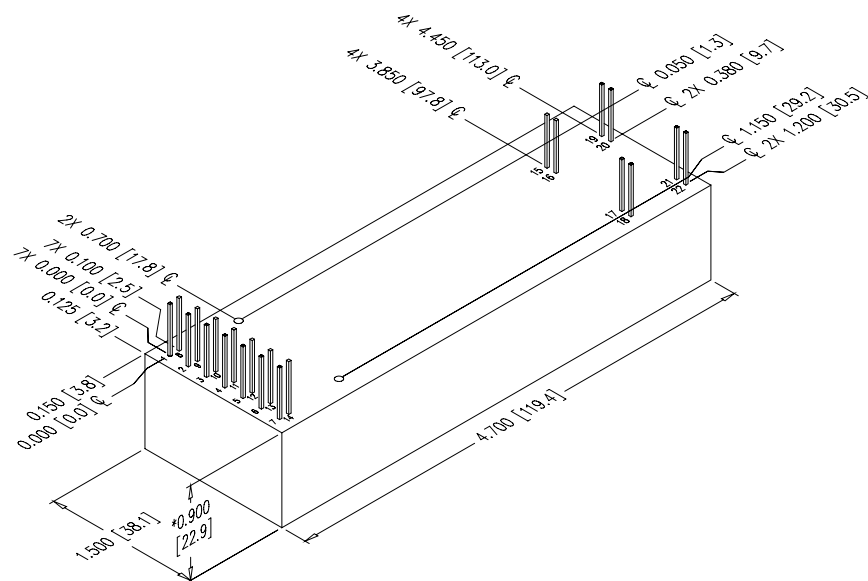
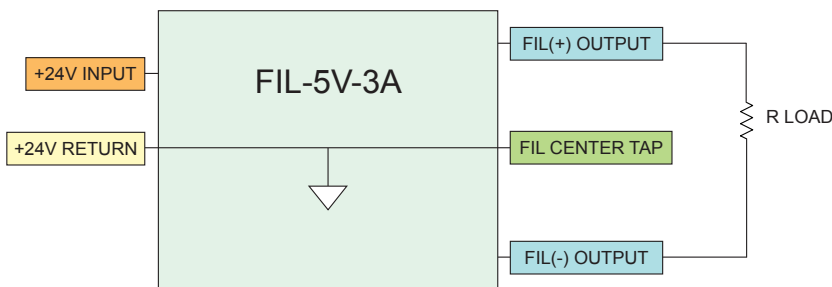

### CONSTRUCTION

Epoxy-filled DAP box certified to ASTM-D-5948

### SIZE

Volume:  
6.35 in<sup>3</sup> (104cc)  
Weight:  
6.75 oz (191g)

### TOLERANCE

Overall ±0.050" (1.27)  
Pin to Pin ±0.015" (0.38)  
Mounting hole locations ±0.025" (0.64)

### NOTES

-M equipped units are an additional 0.030" (0.76) in height. Contact UV Customer Service for drawings of models equipped with -E or -H options.

[Downloadable drawings \(complete with mounting & pin information\) and 3D models are available online.](#)

CONNECTIONS	
PIN	FUNCTION
1 & 8	Input-Power Ground
2 & 9	Positive Power Input
3	Iout Monitor
4	Enable/Disable
5	Signal Ground
6	Voltage Programming
7	+10.0V Reference Output
10	Sync In
11	Imode Indicator
12	Vmode Indicator
13	Current Programming
14, 17, & 18	Vout Monitor
15 & 16	Fil Output (-)
19 & 20	Fil Output (+)
21 & 22	Center Tap

All grounds joined internally.



Non-RoHS compliant units are available. Please contact the factory for more information.

Manufactured in USA

ORDERING INFORMATION		
Type	0 to 5 VDC Output	FIL-5V
Current	Current Output (0 to 3A)	-3A
Case	'Eared' Chassis Mounting Plate	-E
Heat Sink	.400" High (sized to fit case)	-H
Shield	Six-sided Mu-Metal Shield	-M

Example: **FIL-5V-3A-M**



Rev. E 10/14



Making High Voltage Easier!®

1800 Ocean Avenue, Ronkonkoma, NY 11779  
Phone: 1-631-471-4444 Fax: 1-631-471-4696 www.ultravolt.com



Компания «ЭлектроПласт» предлагает заключение долгосрочных отношений при поставках импортных электронных компонентов на взаимовыгодных условиях!

Наши преимущества:

- Оперативные поставки широкого спектра электронных компонентов отечественного и импортного производства напрямую от производителей и с крупнейших мировых складов;
- Поставка более 17-ти миллионов наименований электронных компонентов;
- Поставка сложных, дефицитных, либо снятых с производства позиций;
- Оперативные сроки поставки под заказ (от 5 рабочих дней);
- Экспресс доставка в любую точку России;
- Техническая поддержка проекта, помощь в подборе аналогов, поставка прототипов;
- Система менеджмента качества сертифицирована по Международному стандарту ISO 9001;
- Лицензия ФСБ на осуществление работ с использованием сведений, составляющих государственную тайну;
- Поставка специализированных компонентов (Xilinx, Altera, Analog Devices, Intersil, Interpoint, Microsemi, Aeroflex, Peregrine, Syfer, Eurofarad, Texas Instrument, Miteq, Cobham, E2V, MA-COM, Hittite, Mini-Circuits, General Dynamics и др.);

Помимо этого, одним из направлений компании «ЭлектроПласт» является направление «Источники питания». Мы предлагаем Вам помощь Конструкторского отдела:

- Подбор оптимального решения, техническое обоснование при выборе компонента;
- Подбор аналогов;
- Консультации по применению компонента;
- Поставка образцов и прототипов;
- Техническая поддержка проекта;
- Защита от снятия компонента с производства.



#### Как с нами связаться

**Телефон:** 8 (812) 309 58 32 (многоканальный)

**Факс:** 8 (812) 320-02-42

**Электронная почта:** [org@eplast1.ru](mailto:org@eplast1.ru)

**Адрес:** 198099, г. Санкт-Петербург, ул. Калинина, дом 2, корпус 4, литера А.