

# Basler pulse

## AREA SCAN CAMERAS



- Compact, low-weight camera with elegant metal housing
- Most pristine and colorful images with high-quality CMOS sensors
- Your secure investment due to future-proof USB3 Vision technology
- Designed to fulfill long-term availability
- Excellent price/performance ratio

# OVERVIEW

## Basler pulse – Your New Sophisticated Partner in Elegant Design

In over 25 years of experience in the vision industry, we have gathered the technical expertise to develop cameras with the highest quality standards and very attractive pricing. The pulse camera series has been developed to meet the requirements of a broad variety of vision applications, and combines the established Basler quality with a lightweight and small-size metal housing.

The Basler pulse is an ideal mix of latest technology and sharp design. It offers a robust yet high quality metal housing with tripod socket, and a CS-mount which can easily be converted to C- or S-mount. Equipped with the future-proof USB3 Vision interface, the Basler pulse has great stability and impressively low power consumption – only 1.3 watts. It also provides backwards compatibility to USB 2.0.

With PGI, the pulse camera offers a proprietary new feature set. PGI is a powerful in-camera image optimization that improves your images using the full speed of your camera, and has a unique combination of features consisting of 5x5 debayering, color-anti-aliasing, denoising and improved sharpness. This gives you the opportunity to get the best pictures directly from your camera without any additional CPU load. Use the options of Basler pylon Camera Software Suite to enable PGI, or change settings for selected PGI components for optimal results. Learn more about PGI at [www.baslerweb.com/PGI](http://www.baslerweb.com/PGI).

This compact camera is available with the newest generation of CMOS sensor technology. These sensors come with global or rolling shutter, and are available in a broad variety of resolutions from 1.2 MP up to 5 MP. Thanks to frame rates from 14 up to 60 fps, this series is also a very good choice for live images. The new image enhancement algorithms offer precise image adjustments for specific project requirements as well as for human vision.

## The Basler pulse is suitable for the following applications, and several more:

- Educational, routine, and scientific microscopy
- Laboratory scientific, diagnostic equipment, and automation
- Ophthalmology
- Dermatology
- Patient positioning control and virtual patient observation
- Border and access control
- People recognition, counting, and tracking
- In-vehicle automatic license plate recognition (ALPR)
- Wheel alignment

If you are looking for a sophisticated high-quality camera, the Basler pulse is the right solution for you and your application!

### Your benefits include:

- Compactness: Very low weight, small size and low power consumption
- Easy system integration: Robust and high quality metal housing incl. CS-mount and tripod socket
- Long-term availability of camera series
- Secure investment: USB3 Vision interface as one-cable standards-based solution
- Comprehensive support for your operating system
- Excellent price/performance ratio



# TYPICAL APPLICATIONS

## Microscopy

In digital microscopy, cameras for image acquisition and processing must provide outstanding image quality, excellent color fidelity, fast live images and short reaction times. Clear contrasts are essential for real-time monitoring, documentation or reproducible analytics.

The pulse provides all these features, making it a great fit for educational practice, routine laboratory, scientific applications or process/quality control. With its multiple resolution options, USB 3.0 interface, one-cable solution and sophisticated design, the pulse is a natural choice for a broad range of microscopy applications.



## Dermatology

In dermatology, it is crucial to watch, document and analyze skin texture, especially in the context of early cancer diagnosis. Skin lesions are assessed and documented, and wound repair processes monitored. In cosmetics, high resolution images of skin, hair and scalp are used to measure and analyze a variety of health parameters.

The pulse camera offers elegant design, durable housing, and outstanding image quality. With its small size, ease of integration and operation, it is a suitable choice for dermatoscopy or cosmetic skin analysis.



## People Recognition, Counting and Tracking

In retail shops, cameras support counting and tracking of people to record customer behavior. Heat maps can define areas of interest such as in advertising panels and grocery displays. Together with face recognition software, a customer's age, gender or ethnicity can be identified. This counting and profiling data helps to optimize advertisement or product arrangements in stores. With high image quality of up to 5 MP, the pulse series is a perfect fit to provide data for precise profiling of customers and their behavior. Its small and elegant metal housing ensures a discreet installation.



## In-Vehicle Automatic License Plate Recognition

Cameras deliver images for automatic license plate recognition (ALPR), to support enforcement, tolling and police investigation. Equipped with the simple-to-use USB 3.0 interface and tripod socket, the pulse camera can easily be integrated into these mass surveillance systems.

For in-vehicle use, this system blends in well due to its compact, elegant housing and one-cable set-up. With the Aptina AR0134 (1.2 MP global shutter) sensor, the pulse provides high image quality even with low light conditions or moving targets, for a very attractive price.

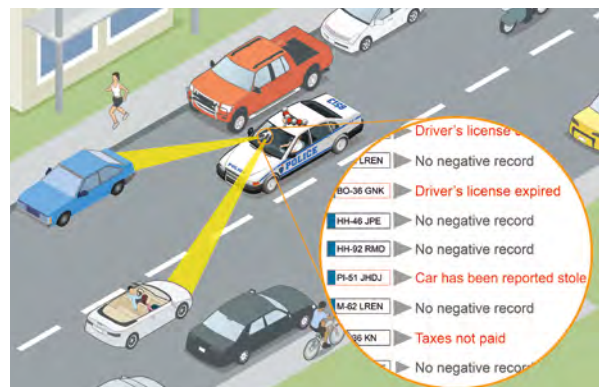

Get your free version:  
[www.baslerweb.com/pylon](http://www.baslerweb.com/pylon)

## Basler pylon Camera Software Suite

The pylon Camera Software Suite operates with all Basler line scan and area scan cameras - no matter what interface they use. It offers stable, reliable and flexible data exchange between Basler cameras and PCs, for Windows and Linux on x86 as well as on ARM based systems and OS X – at a very low CPU load.

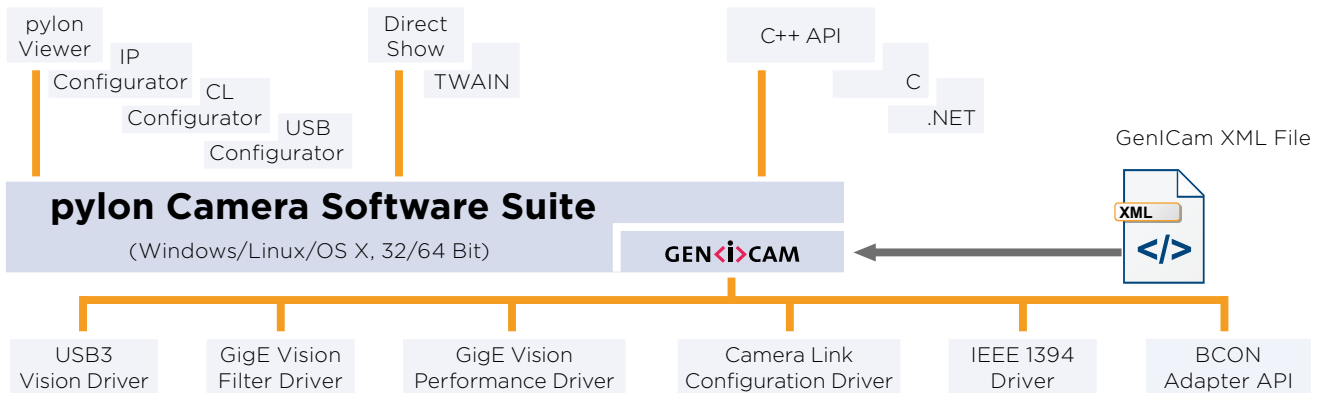

The architecture of the pylon Camera Software Suite is based on GenICam Technology, which offers you easy access to the newest camera models and the latest features. Changes to an existing camera device in your application essentially become a plug-and-play process.

An easy-to-use set of tools lets you configure the camera's interface. Use the **pylon Viewer** to set camera parameters, to capture and display images, and to evaluate the camera.

The pylon **USB3 Vision Driver** fully supports the USB3 Vision standard. It allows Basler USB 3.0 cameras to use the full speed and bandwidth of USB 3.0 for image transmission while reducing resource load and using off-the-shelf hardware components.

The **pylon GigE Vision Drivers** quickly separate incoming packets carrying image data from other traffic on the network and make the data available for use by your vision application while requiring the lowest CPU resources.

The pylon **IEEE 1394b Driver** gives you access to a well-established interface technology, and the pylon **Camera Link Configuration Driver** offers comfortable access to all camera parameters of Basler's latest Camera Link families ace, aviator, and racer.

The **BCON Adapter API** allows easy implementation

of an adapter to communicate with the systems I<sup>2</sup>C interface. A ready to use sample adapter implementation is also provided.

The pylon Camera Software Suite also contains a powerful SDK that supports any type of application development. The pylon package contains the following main modules. Each one can be individually selected/unselected during the installation process, preventing the installation of unneeded modules on your system:

- USB3 Vision Driver
- GigE Vision Filter Driver
- GigE Vision Performance Driver
- IEEE 1394 Driver
- BCON Adapter API
- Camera Link Serial Communication Driver
- pylon Viewer
- SDK for all cameras; C, C++, .NET (C#, VB.NET, ...); the 'pylon for Linux' version only supports the GigE and USB 3.0 interface via a C++ API

The pylon Camera Software Suite can be downloaded for free at [www.baslerweb.com/pylon](http://www.baslerweb.com/pylon). For more information on the installation process, refer to the pylon Installation Guide. The helpful pylon Release Notes contain all improvements and bug fixes since the first pylon version.

# TECHNICAL DETAILS

## Specifications



Basler pulse	puA1280-54um/uc	puA1600-60um/uc	puA1920-30um/uc	puA2500-14um/uc
<b>Camera</b>				
Resolution (H×V pixels)	1280×960	1600 × 1200	1920×1080	2592×1944
Sensor	Aptina AR0134	EV76C570	Aptina MT9P031	Aptina MT9P031
Sensor Size (optical)	1/3"	1/1.8"	1/3.7"	1/2.5"
Sensor Technology	CMOS, global shutter	CMOS, global shutter	CMOS, rolling shutter	CMOS, rolling shutter
Pixel Size [µm <sup>2</sup> ]	3.75×3.75	4.5 × 4.5	2.2×2.2	2.2×2.2
Frame Rate [fps]	54	60	30	14
Mono/Color	Mono/Color			
Video Output Format	Mono (8,12), YUV 4:2:2 Packed (YCbCr 422), Bayer (8,12), RGB			
Interface	USB 3.0			
Exposure Control	Programmable via the camera API			
<b>Mechanical/Electrical</b>				
Dimensions (d×L)	38.8 mm×28.2 mm			
Housing Temperature	Up to 50°C			
Lens Mount	CS-mount			
Power Requirements	Via USB 3.0 interface			
Power Suspend Mode	Yes, less than 20 mW, configurable			
Power Consumption (typical)	-1.3W			
Weight (typical)	<60g			
Conformity	CE, RoHS, UL, USB3 Vision, USB-IF (in preparation)			
<b>Software/Driver</b>				
Driver	Basler pylon Camera Software Suite or 3rd party USB3 Vision Software			
Operating System	Windows, Linux, Mac OS X			
Conformity	USB3 Vision, GenICam			

Specifications are subject to change without prior notice.  
 Latest specifications and availability can be found on our website [www.baslerweb.com/pulse](http://www.baslerweb.com/pulse). Please visit [www.baslerweb.com/manuals](http://www.baslerweb.com/manuals) for the detailed camera User's Manual and [www.baslerweb.com/thirdparty](http://www.baslerweb.com/thirdparty) for information on third party software.

## Dimensions (in mm)

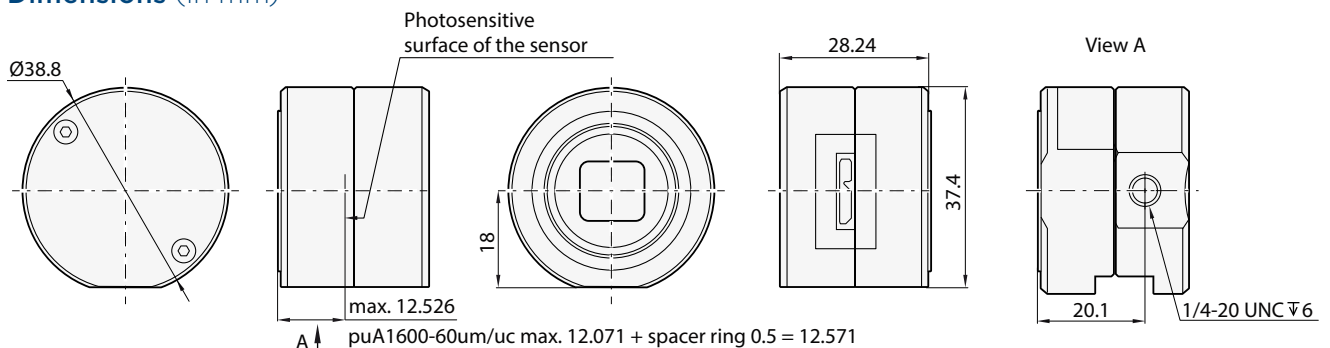

## OTHER INFORMATION

### How Does Basler Ensure Superior Quality and Reliable High Performance?

Our approach to quality assurance is rigorous: we continually audit all facets of our business to ensure powerful performance, increase efficiency and reduce costs for our customers. We are compliant with all major quality standards including ISO 9001, CE, RoHS, and more. To ensure consistently high product quality, we employ several quality inspection procedures during manufacturing.

Every Basler camera is subjected to exhaustive optical and mechanical tests before leaving the factory. We have developed a unique combination of optics, hardware, and software tools that can quickly and efficiently calibrate a camera and measure its performance against a set of standard performance criteria. Regardless of what technology or camera model you choose you can be assured of consistent performance.

### 3-Year Warranty

Basler offers a 3-year warranty for their cameras and Basler Lenses. We make this unprecedented promise because we have unparalleled confidence in our products. We continually reinvest in research, development and superior manufacturing capabilities so that our customers can fully rely on the products we manufacture.

### About Basler

Founded in 1988, Basler is a leading global manufacturer of high quality digital cameras and lenses for factory automation, medical & life sciences, retail and traffic applications. The company employs 500 people at its headquarters in Ahrensburg, Germany and subsidiaries in the United States and Asia.

Basler's portfolio of products offers customers the vision industry's widest selection of industrial and network cameras as well as lenses. Today it includes some 300 camera models - and it's still growing. We're committed to developing technology that drives business results for our customers: cameras and lenses that are easy to use, easy to integrate, and deliver an exceptional price/performance ratio.



**Basler AG**  
**Germany, Headquarters**  
Tel. +49 4102 463 500  
sales.europe@baslerweb.com

**Basler, Inc.**  
**USA**  
Tel. +1 610 280 0171  
sales.usa@baslerweb.com

**Basler Asia Pte Ltd.**  
**Singapore**  
Tel. +65 6367 1355  
sales.asia@baslerweb.com

©Basler AG, No. 02, 09/2016  
ID 2000035926

Please visit our website to find further Basler offices and representatives close to you:  
[www.baslerweb.com/sales](http://www.baslerweb.com/sales)

**BASLER**  
the power of sight



Компания «ЭлектроПласт» предлагает заключение долгосрочных отношений при поставках импортных электронных компонентов на взаимовыгодных условиях!

Наши преимущества:

- Оперативные поставки широкого спектра электронных компонентов отечественного и импортного производства напрямую от производителей и с крупнейших мировых складов;
- Поставка более 17-ти миллионов наименований электронных компонентов;
- Поставка сложных, дефицитных, либо снятых с производства позиций;
- Оперативные сроки поставки под заказ (от 5 рабочих дней);
- Экспресс доставка в любую точку России;
- Техническая поддержка проекта, помощь в подборе аналогов, поставка прототипов;
- Система менеджмента качества сертифицирована по Международному стандарту ISO 9001;
- Лицензия ФСБ на осуществление работ с использованием сведений, составляющих государственную тайну;
- Поставка специализированных компонентов (Xilinx, Altera, Analog Devices, Intersil, Interpoint, Microsemi, Aeroflex, Peregrine, Syfer, Eurofarad, Texas Instrument, Miteq, Cobham, E2V, MA-COM, Hittite, Mini-Circuits, General Dynamics и др.);

Помимо этого, одним из направлений компании «ЭлектроПласт» является направление «Источники питания». Мы предлагаем Вам помощь Конструкторского отдела:

- Подбор оптимального решения, техническое обоснование при выборе компонента;
- Подбор аналогов;
- Консультации по применению компонента;
- Поставка образцов и прототипов;
- Техническая поддержка проекта;
- Защита от снятия компонента с производства.



#### Как с нами связаться

**Телефон:** 8 (812) 309 58 32 (многоканальный)

**Факс:** 8 (812) 320-02-42

**Электронная почта:** [org@eplast1.ru](mailto:org@eplast1.ru)

**Адрес:** 198099, г. Санкт-Петербург, ул. Калинина, дом 2, корпус 4, литера А.