

# Miniature Ceramic Resonator



AWSCR-CELA

3.2 x 1.3 x 1.0 mm

RoHS/RoHS II Compliant

Pb in ceramic, exemption (7c-1)

This product is not Moisture Sensitive - MSL = 1

## Features

- Industry standard footprint
- Low resonance impedance
- Built-in capacitance options
- Wide operating temperatures in extended industry range

## Applications

- Metering systems
- Remote control
- Microprocessor
- Industrial control
- Electric appliances

## Electrical Specifications

Parameters	Min	Typ.	Max	Units	Notes
Frequency Range	8.00		12.00	MHz	
Resonant Impedance (Ro)		40		$\Omega$	8.00 MHz - 12.00 MHz
Standard Built-in Capacitance (C1=C2)		15		pF	8.00 MHz - 12.00 MHz (Tol 1pF $\pm$ 20%)
	Other options: 10, 22, 30, 33				
Frequency Tolerance	-0.5		0.5	%	
Temperature Coefficient of Oscillation Frequency (%) max.	-0.2		0.2	%	Oscillator Frequency drift (-40 °C to +85 °C)
Withstanding Voltage			50	V	DC, 1 min max
Voltage Rating	(1) D.C. Voltage		6	V	
	(2) A.C. Voltage		15	Vp-p	
Insulation Resistance (Ri)	500			M $\Omega$	10V, 1 min
Operation Temperature	-40		+85	°C	
Storage Temperature	-55		+85	°C	
Aging Rate max (Fosc) * For 10 years	-0.2		0.2	%	From Initial value

\* Components shall be left in a chamber of +85 °C  $\pm$  2 °C for 1000 hours, then measured after leaving in natural condition for 1 hour.

# Miniature Ceramic Resonator



AWSCR-CELA

3.2 x 1.3 x 1.0 mm

RoHS/RoHS II Compliant

Pb in ceramic, exemption (7c-I)

This product is not Moisture Sensitive - MSL = 1

## Options and Part Identification

AWSCR - □□.□□ CELA - C□□ - □

Frequency (MHz)	Size (mm)	Frequency Band	Operating Temperature	Built-in Cap	Packaging
8.000 - 12.000	CE = 3.2 x 1.3	L = Lower Band	A = -40 °C to 85 °C	15 pF (Standard) 10/22/30/33 pF (Other)	T3 = 3000 pcs/reel

## Test Circuit and Conditions

Parts shall be tested under the condition (Temp: 20 °C ± 15 °C, Humidity: 65 ± 20 % R.H.) unless the standard condition (Temp: 25 °C ± 3 °C, Humidity: 65 ± 10 % R.H.) is regulated to measure.

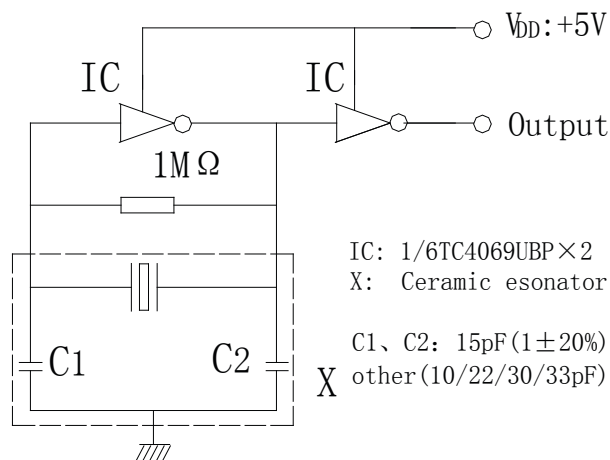

# Miniature Ceramic Resonator



AWSCR-CELA

3.2 x 1.3 x 1.0 mm  
RoHS/RoHS II Compliant  
Pb in ceramic, exemption (7c-1)  
This product is not Moisture Sensitive - MSL = 1

## Outline Dimensions

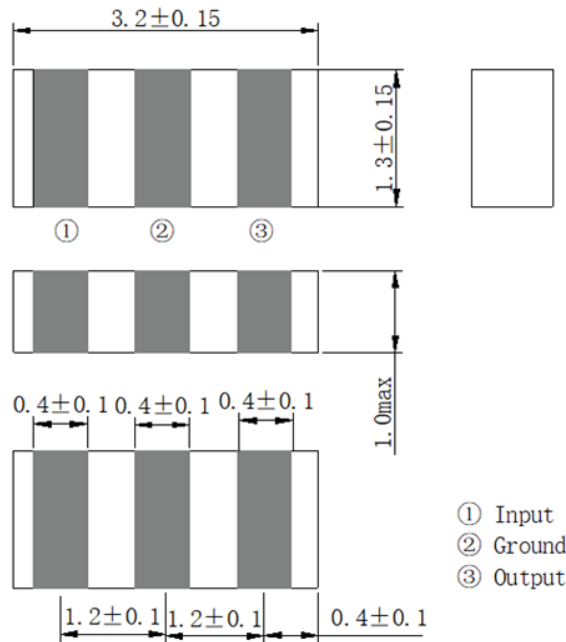

Unit: mm

# Miniature Ceramic Resonator



AWSCR-CELA

3.2 x 1.3 x 1.0 mm  
RoHS/RoHS II Compliant  
Pb in ceramic, exemption (7c-I)  
This product is not Moisture Sensitive - MSL = 1

## Recommended Land Pattern

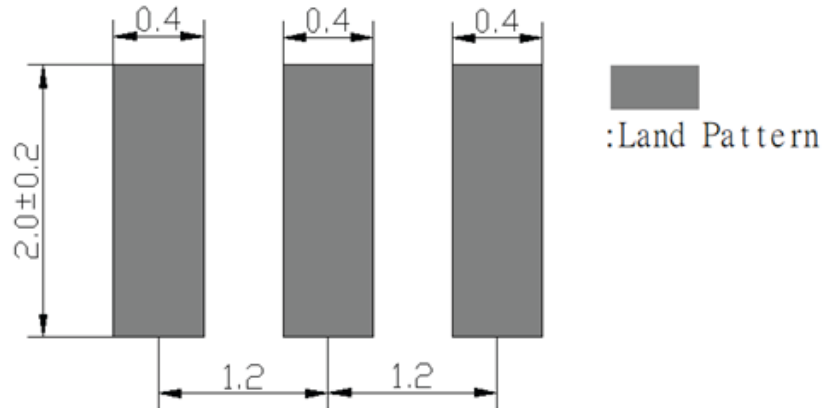

Unit: mm

## Recommended Reflow Profile

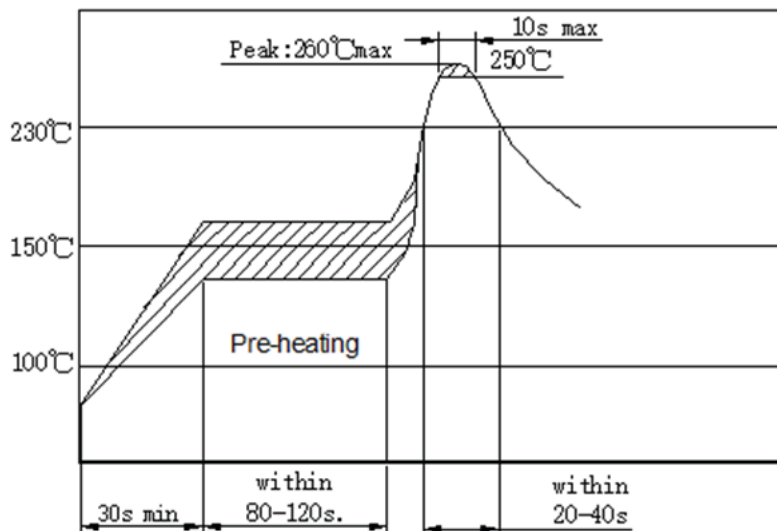

# Miniature Ceramic Resonator



AWSCR-CELA

3.2 x 1.3 x 1.0 mm  
**RoHS/RoHS II Compliant**  
 Pb in ceramic, exemption (7c-I)  
 This product is not Moisture Sensitive - MSL = 1

## Packaging

T3: 3000 pcs/reel

### Reel Dimension

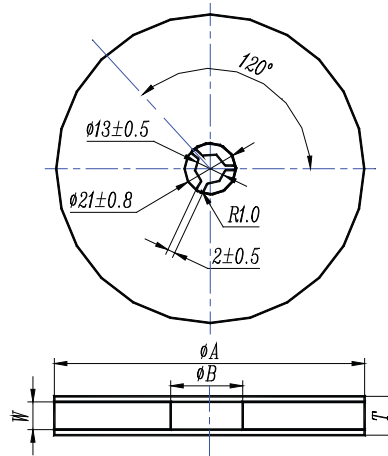

Unit: mm

$\phi A$	$\phi B$	W	T	Pieces per reel	Carrier tape size
180 ± 3	60 min	8.4 min	12.4 max	3000 typ.	8

### Packaging Sketch

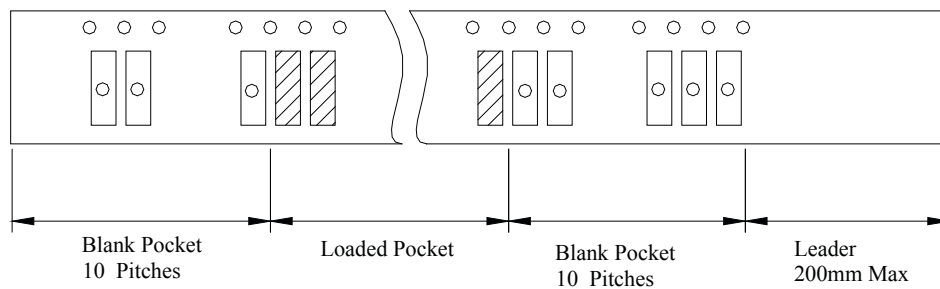

# Miniature Ceramic Resonator



AWSCR-CELA

3.2 x 1.3 x 1.0 mm  
RoHS/RoHS II Compliant  
Pb in ceramic, exemption (7c-1)  
This product is not Moisture Sensitive - MSL = 1

## Packaging

### Test Condition for Peel-Off Strength

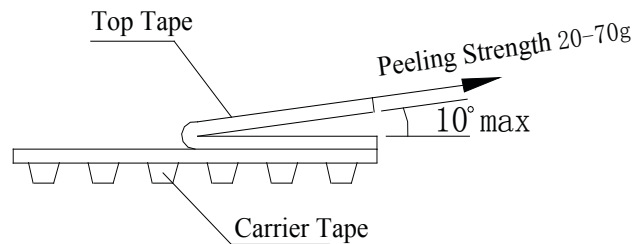

## Caution

1. Do not apply excess mechanical stress to the component and terminals during soldering. Do not use this product if it is bent or damaged.
2. Do not clean or wash the component for it is not hermetically sealed.
3. Do not use a strong acidity flux with more than 0.2 wt% chlorine content during soldering.
4. Do not place or use the item close to fire.
5. Please ensure the component is thoroughly evaluated in your application circuit as the specification mentions the quality of the component as a single unit.
6. Expiry date (Shelf life) of the products is 12 months after the date of delivery under the conditions of a sealed and an unopened package. Please use the products within 12 months after delivery. If the item is stored for more than 12 months, use caution before use as the item may be degraded in the solderability or develop rust. Please confirm solderability and characteristics for the products regularly.

**ATTENTION:** Abracon LLC's products are COTS – Commercial-Off-The-Shelf products; suitable for Commercial, Industrial and, where designated, Automotive Applications. Abracon's products are not specifically designed for Military, Aviation, Aerospace, Life-dependent Medical applications or any application requiring high reliability where component failure could result in loss of life and/or property. For applications requiring high reliability and/or presenting an extreme operating environment, written consent and authorization from Abracon LLC is required. Please contact Abracon LLC for more information.



5101 Hidden Creek Ln Spicewood TX 78669  
Phone: 512-371-6159 | Fax: 512-351-8858  
For terms and conditions of sales, please visit:  
[www.abracon.com](http://www.abracon.com)

REVISED: 04-17-19

ABRACON IS  
ISO9001-2015  
CERTIFIED



Компания «ЭлектроПласт» предлагает заключение долгосрочных отношений при поставках импортных электронных компонентов на взаимовыгодных условиях!

Наши преимущества:

- Оперативные поставки широкого спектра электронных компонентов отечественного и импортного производства напрямую от производителей и с крупнейших мировых складов;
- Поставка более 17-ти миллионов наименований электронных компонентов;
- Поставка сложных, дефицитных, либо снятых с производства позиций;
- Оперативные сроки поставки под заказ (от 5 рабочих дней);
- Экспресс доставка в любую точку России;
- Техническая поддержка проекта, помощь в подборе аналогов, поставка прототипов;
- Система менеджмента качества сертифицирована по Международному стандарту ISO 9001;
- Лицензия ФСБ на осуществление работ с использованием сведений, составляющих государственную тайну;
- Поставка специализированных компонентов (Xilinx, Altera, Analog Devices, Intersil, Interpoint, Microsemi, Aeroflex, Peregrine, Syfer, Eurofarad, Texas Instrument, Miteq, Cobham, E2V, MA-COM, Hittite, Mini-Circuits, General Dynamics и др.);

Помимо этого, одним из направлений компании «ЭлектроПласт» является направление «Источники питания». Мы предлагаем Вам помощь Конструкторского отдела:

- Подбор оптимального решения, техническое обоснование при выборе компонента;
- Подбор аналогов;
- Консультации по применению компонента;
- Поставка образцов и прототипов;
- Техническая поддержка проекта;
- Защита от снятия компонента с производства.



#### Как с нами связаться

**Телефон:** 8 (812) 309 58 32 (многоканальный)

**Факс:** 8 (812) 320-02-42

**Электронная почта:** [org@eplast1.ru](mailto:org@eplast1.ru)

**Адрес:** 198099, г. Санкт-Петербург, ул. Калинина, дом 2, корпус 4, литера А.