

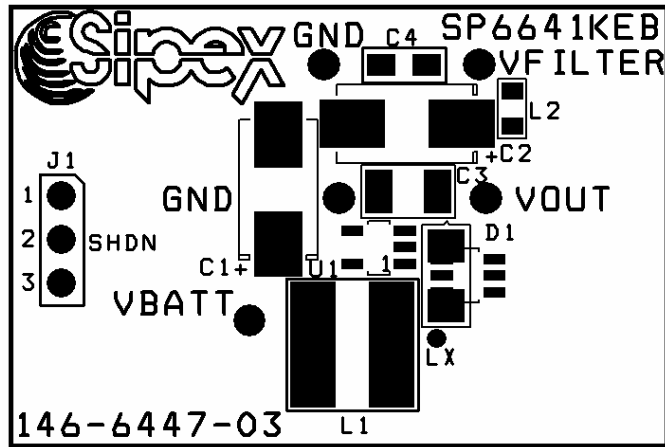

SP6641A/6641B Low Noise Evaluation Board

- Easy Evaluation for the SP6641A/6641B Single or Dual Cell Alkaline to 3.3V or 5V Output
- SP6641B provides up to 500mA output current with less than 50mVpp ripple
- High Efficiency: up to 87%
- SOT23-5 Package & SMT components for small, low



SP6641A/6641B Evaluation Board Schematics

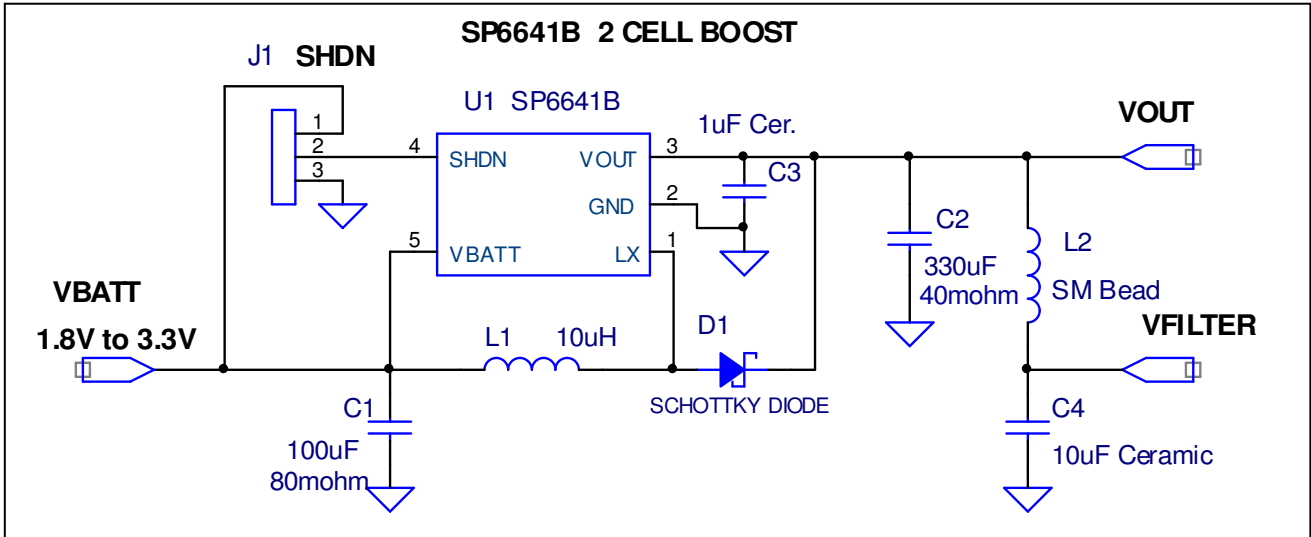
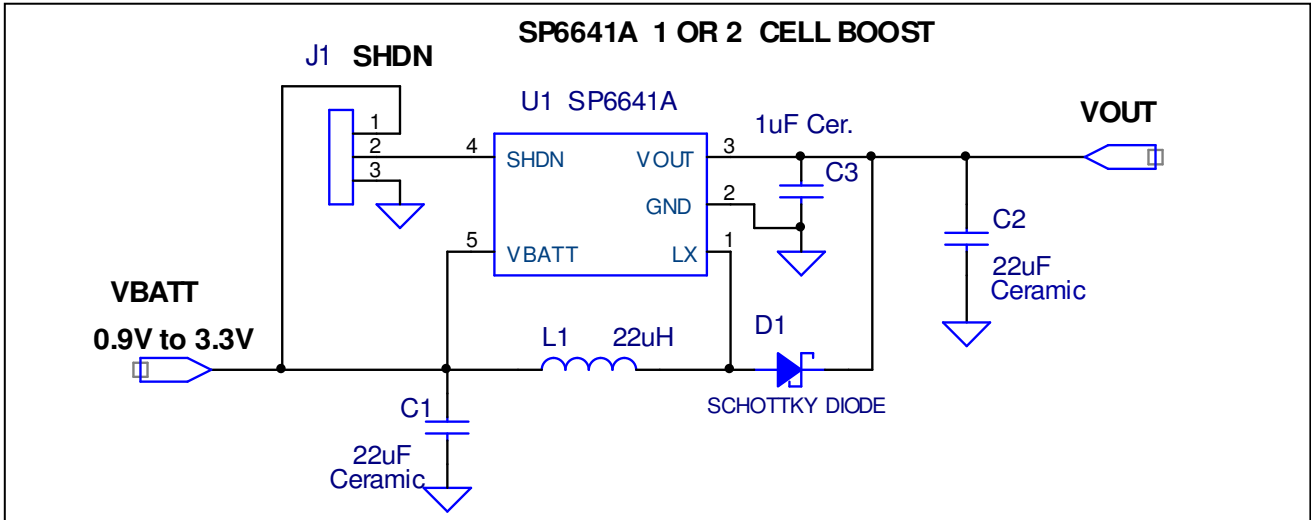

USING THE EVALUATION BOARD

1) Powering Up the SP6641A/6641B Circuit

The SP6641A/6641B Evaluation Board can be powered from inputs from a +0.9V to +3.3V from 1 or 2 alkaline cells or a power supply. Connect with short leads directly to the “Vbatt” and “Gnd” posts. Monitor the Output Voltage and connect the Load between the “Vout” post and the “GND” post.

2) Using the J1 Jumper: Enabling the SP6641A/6641B Output and using the Shutdown Mode

The SP6641A/6641B output will be enabled if the J1 Jumper is in the upper or pin 1 to 2 position. If J1 is in the pin 2 to 3 position, the Shutdown pin is brought to GND, which puts the SP6641A/6641B in the low quiescent Shutdown Mode.

3) Selecting the Inductor

In selecting an inductor, the saturation current specified for the inductor needs to be greater than the SP6641A/6641B peak current to avoid saturating the inductor, which would result in a loss in efficiency and could damage the inductor. The SP6641A evaluation board uses a Sumida CDRH5D28 22uH inductor with an Isat value of 0.9A and a DCR of 0.095ohms, which easily handles the Ipeak of 0.33A of the SP6641A and will deliver high efficiencies. The SP6641B evaluation board uses a Sumida CDRH5D28 10uH inductor with an Isat value of 1.3A and a DCR of 0.065ohms, which easily handles the Ipeak of 1.0A of the SP6641B and will deliver high efficiencies. Other inductors could be selected provided their Isat is greater than the Ipeak of the SP6641A/6641B.

4) Selecting the Capacitors and Filter Components

For the SP6641A, 22uF ceramic capacitors are used, which work well due to their inherently low ESR, which will help produce low peak to peak output ripple, and reduce high frequency spikes as well due to their low impedance. To obtain low peak to peak ripple for the SP6641B, the output capacitor needs to have ESR as low as 35 to 40 mohms and have a value of at least 100uF, for which the 330uF Sanyo POSCAP was chosen for its 40mohms max. ESR. Other ultra low ESR capacitors such the radial lead 100uF Sanyo OSCON or one of the new SM low ESR Polymer capacitors like the 100uF Panasonic UD series could be used. This low ripple is obtained with no output spikes through the use of a LC filter consisting of small 0805 SM bead core L2 and 10uF ceramic capacitor C3.

POWER SUPPLY DATA

Power supply data is provided for the “B” version of the SP6641B, which has a peak inductor current limit of 1A, with the 3.3V output option. Figure 1 shows the switching signals still present as 1.0V spikes on the 330uF capacitor C2. Note that no output spikes are seen in figures 2 and 3 through the use of a small LC filter after the 330uF capacitor. The SP6641B’s low output ripple of 45 to 50mVpp is shown for a typical input of 2.0V to 3.0V and an output load of 300mA.

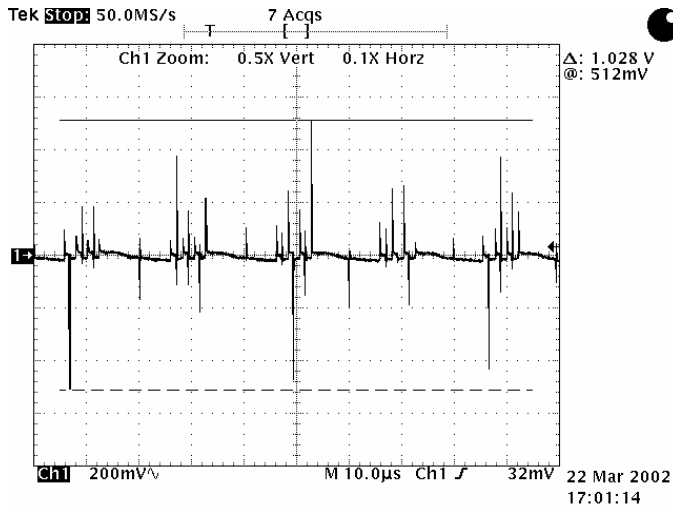

Figure 1. SP6641B Switching Signals on 330uF: $V_{in} = 2.0V$, $I_{out} = 300mA$, Spikes = 1.0Vpp

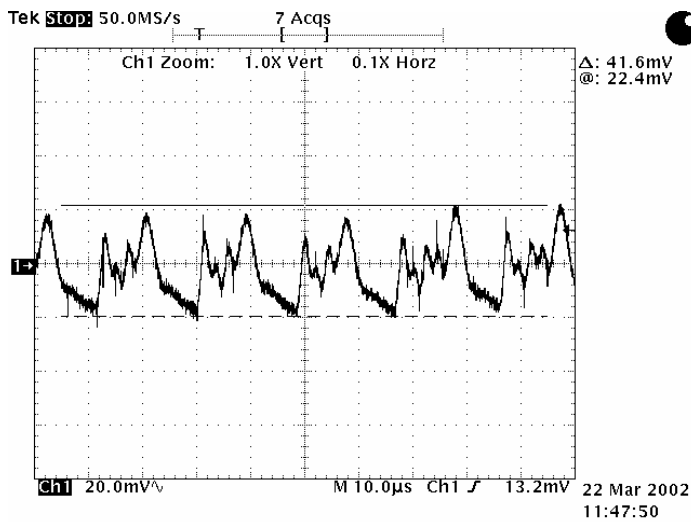

Figure 2. SP6641B Output Ripple: $V_{in} = 2.0V$, $I_{out} = 300mA$, V_{out} ripple = 42mVpp, 51kHz

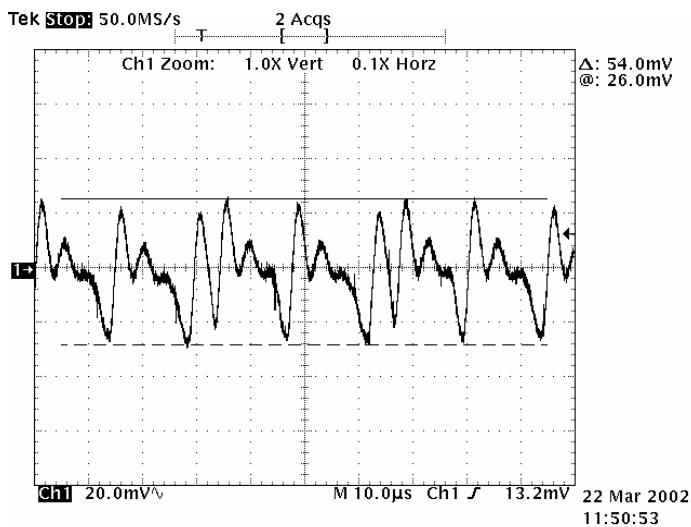

Figure 3. SP6641B Output Ripple: $V_{in} = 3.0V$, $I_{out} = 500mA$, V_{out} ripple = 54mVpp, 50kHz

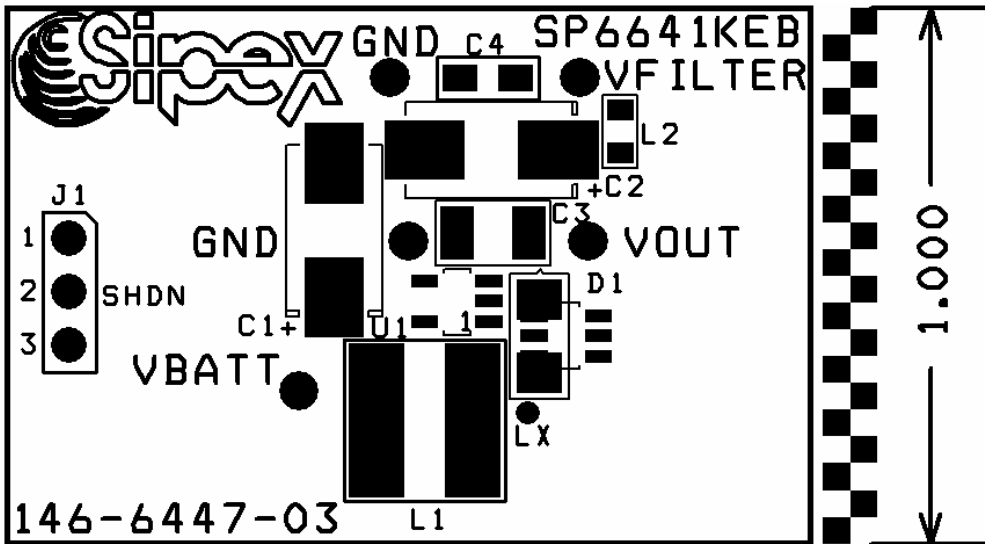

FIGURE 4: SP6641A/6641B COMPONENT PLACEMENT

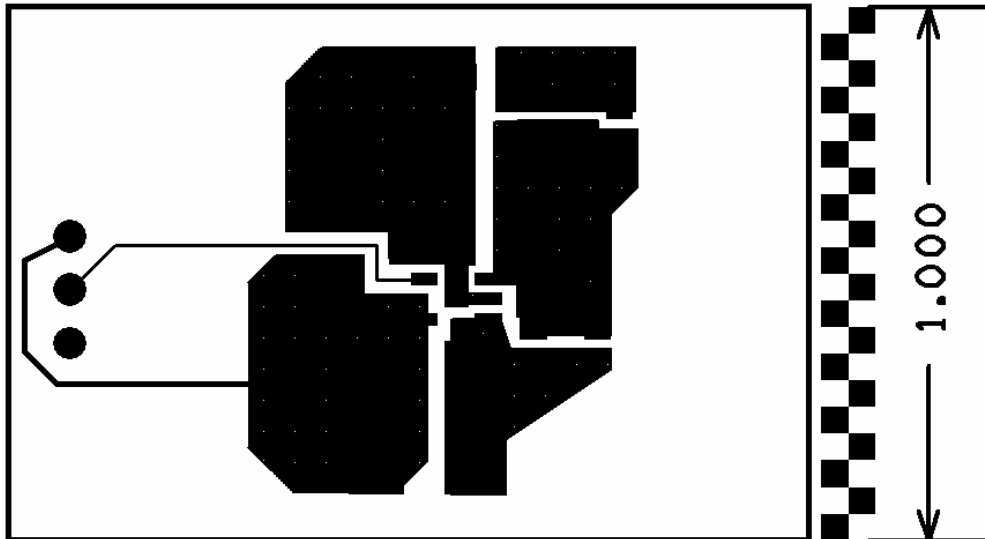

FIGURE 5: SP6641A/6641B PC LAYOUT TOP SIDE

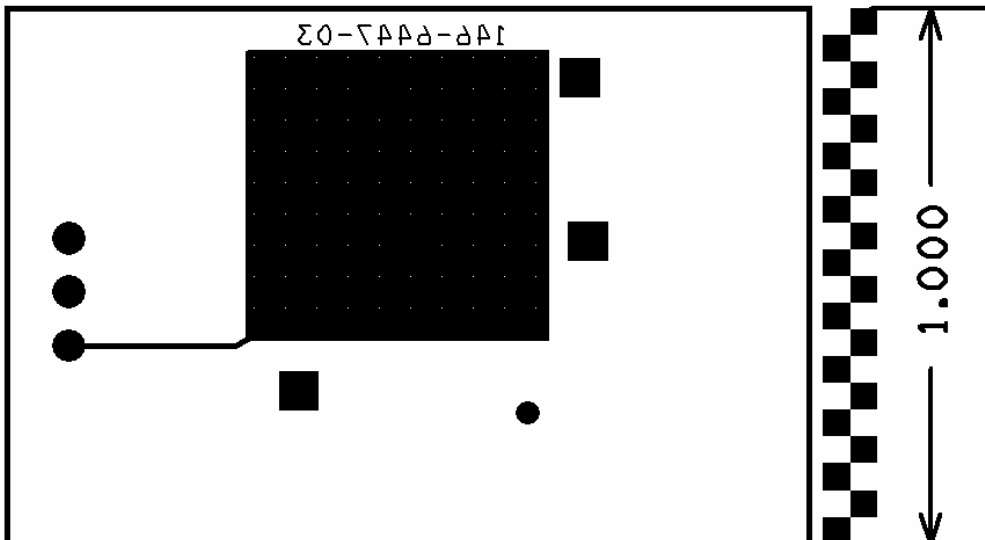

FIGURE 6: SP6641A/6641B PC LAYOUT BOTTOM SIDE

TABLE1: SP6641A BILL OF MATERIALS

Ref. Des.	Qty.	Manufacturer	Part Number	Layout Size LxWxH	Component	Vendor
	1	Sipex Corp.	146-6447-03	1"x1.5"	SP6641 Eval PC Board	Sipex 978-667-8700
U1	1	Sipex Corp.	SP6641AEK-3.3 or 5.0	SOT23-5	5-pin SOT23 Step-Up DC/DC Conv	Sipex
C1,C2	2	TDK Corp	C3225X5R0J226K	1210	Ceramic 6.3V 22uF SM 0.005ohm ESR	TDK 847-803-6100
C3	1	TDK Corp	C2012X5R1A105K	805	Ceramic 10V 1uF SM 0.02ohm ESR	TDK 847-803-6100
L1	1	Sumida	CDRH5D28-220	5.7x5.5x3mm	22uH, 0.90A, 0.095ohm, SM Inductor	Sumida 847-956-0666
D1	1	STMicroelectronics	STPS0520Z	SOD-123	Schottky diode 0.5A, 0.385V	STMicro 847-585-3023
TP	5	Mill-Max	0300-115-01-4727100	.042 Dia	Test Point Female Pin	800-Digi-Key
J1	1	Sullins	PTC36SAAN	.23x.12	3-Pin Header	800-Digi-Key

TABLE2: SP6641B BILL OF MATERIALS

Ref. Des.	Qty.	Manufacturer	Part Number	Layout Size LxWxH	Component	Vendor
	1	Sipex Corp.	146-6447-03	1"x1.5"	SP6641 Eval PC Board	Sipex 978-667-8700
U1	1	Sipex Corp.	SP6641BEK-3.3 or 5.0	SOT23-5	5-pin SOT23 Step-Up DC/DC Conv	Sipex
C1	1	Sanyo Video	10TPA100M	7343	POSCAP 10V 100uF SM 0.080ohm Max. ESR	Sanyo 978-922-6573
C2	1	Sanyo Video	6TPB330M	7343	POSCAP 6.3V 330uF SM 0.040ohm Max. ESR	Sanyo 978-922-6573
C3	1	TDK Corp	C2012X5R1A105M	805	Ceramic 10V 1uF SM 0.02ohm ESR	TDK 847-803-6100
C4	1	TDK Corp	C3216X5R0J106M	1206	Ceramic 6.3V 10uF SM 0.005ohm ESR	TDK 847-803-6100
L1	1	Sumida	CDRH5D28-100	5.7x5.5x3	10uH, 1.3A, 0.065ohm, SM Inductor	Sumida 847-956-0666
L2	1	Panasonic	EXC-ML20A390U	805	SM Bead Core 100MHz	800-Digi-Key
D1	1	Zetex	ZCHS2000	SOT23-6	Schottky diode 2A, 0.42V	Zetex 631-360-2222
TP	5	Mill-Max	0300-115-01-4727100	.042 Dia	Test Point Female Pin	800-Digi-Key
J1	1	Sullins	PTC36SAAN	.23x.12	3-Pin Header	800-Digi-Key
	1	Sullins	STC02SYAN	.2x.1	Shunt	800-Digi-Key

ORDERING INFORMATION

Model	Temperature Range	Package Type
SP6641AKEB-3.3.....	-40°C to +85°C.....	SP6641A 3.3V Evaluation Board
SP6641AEK-3.3.....	-40°C to +85°C.....	5-pin SOT23
SP6641AKEB-5.0.....	-40°C to +85°C.....	SP6641A 5.0V Evaluation Board
SP6641AEK-5.0.....	-40°C to +85°C.....	5-pin SOT23
SP6641BKEB-3.3.....	-40°C to +85°C.....	SP6641B 3.3V Evaluation Board
SP6641BEK-3.3.....	-40°C to +85°C.....	5-pin SOT23
SP6641BKEB-5.0.....	-40°C to +85°C.....	SP6641B 5.0V Evaluation Board
SP6641BEK-5.0.....	-40°C to +85°C.....	5-pin SOT23



Компания «ЭлектроПласт» предлагает заключение долгосрочных отношений при поставках импортных электронных компонентов на взаимовыгодных условиях!

Наши преимущества:

- Оперативные поставки широкого спектра электронных компонентов отечественного и импортного производства напрямую от производителей и с крупнейших мировых складов;
- Поставка более 17-ти миллионов наименований электронных компонентов;
- Поставка сложных, дефицитных, либо снятых с производства позиций;
- Оперативные сроки поставки под заказ (от 5 рабочих дней);
- Экспресс доставка в любую точку России;
- Техническая поддержка проекта, помощь в подборе аналогов, поставка прототипов;
- Система менеджмента качества сертифицирована по Международному стандарту ISO 9001;
- Лицензия ФСБ на осуществление работ с использованием сведений, составляющих государственную тайну;
- Поставка специализированных компонентов (Xilinx, Altera, Analog Devices, Intersil, Interpoint, Microsemi, Aeroflex, Peregrine, Syfer, Eurofarad, Texas Instrument, Miteq, Cobham, E2V, MA-COM, Hittite, Mini-Circuits, General Dynamics и др.);

Помимо этого, одним из направлений компании «ЭлектроПласт» является направление «Источники питания». Мы предлагаем Вам помощь Конструкторского отдела:

- Подбор оптимального решения, техническое обоснование при выборе компонента;
- Подбор аналогов;
- Консультации по применению компонента;
- Поставка образцов и прототипов;
- Техническая поддержка проекта;
- Защита от снятия компонента с производства.



Как с нами связаться

Телефон: 8 (812) 309 58 32 (многоканальный)

Факс: 8 (812) 320-02-42

Электронная почта: org@eplast1.ru

Адрес: 198099, г. Санкт-Петербург, ул. Калинина, дом 2, корпус 4, литера А.