

Product Specification

4.25 Gb/s RoHS Compliant Short-Wavelength 2x7 SFF Transceiver

FTLF8524E2xNy

PRODUCT FEATURES

- Up to 4.25 Gb/s bi-directional data links
- 2x7 pin SFF-like footprint
- Built-in digital diagnostic functions
- 850nm Oxide VCSEL laser transmitter
- Duplex LC connector
- RoHS Compliant and Lead Free
- Up to 500m on 50/125µm MMF, 300m on 62.5/125µm MMF
- Metal enclosure, for lower EMI
- Single 3.3V power supply
- Extended operating temperature range: -10°C to 85°C



APPLICATIONS

- Tri-Rate 1.063/2.125/4.25 Gb/s Fibre Channel

Finisar's FTLF8524E2xNy Small Form Factor (SFF) transceivers comply with the 2x5 standard package defined by the Small Form Factor Multi-Sourcing Agreement (MSA)¹, with the exception of 4 extra pins outlined in Section I below. They are compatible with Fibre Channel FC-PI-2 Rev. 7.0² and are RoHS compliant and lead-free per Directive 2002/95/EC³ and Finisar Application Note AN-2038.

PRODUCT SELECTION

FTLF8524E2xNy

x	G	2 Grounding Pins, Short EMI shield
	K	2 Grounding Pins, Long EMI shield
y	L	Non Rate Selectable - 1x, 2x, 4x Fibre Channel
	V	Rate Selectable - 1x, 2x, 4x Fibre Channel

I. Pin Descriptions

Pin	Symbol	Name/Description	Logic Family
MS	MS	Mounting Studs are for mechanical attachment and are connected to chassis ground. Chassis ground is internally isolated from circuit grounds. Connection to user's ground plane is recommended.	NA
1	V _{EER}	Receiver Ground (Common with Transmitter Ground)	NA
2	V _{CCR}	Receiver Power Supply	NA
3	SD	Signal Detect. Logic 1 indicates normal operation.	LVTTTL
4	RD-	Receiver Inverted DATA out. AC Coupled	See Rx spec.
5	RD+	Receiver Non-inverted DATA out. AC Coupled	See Rx spec.
6	V _{CCT}	Transmitter Power Supply	NA
7	V _{EET}	Transmitter Ground (Common with Receiver Ground)	NA
8	T _{DIS}	Transmitter Disable	LVTTTL
9	TD+	Transmitter Non-Inverted DATA in. AC Coupled.	See Tx spec.
10	TD-	Transmitter Inverted DATA in. AC Coupled	See Tx spec.
A	SDA	Two Wire Digital Diagnostics Data Interface	See Note 1
B	SCL	Two Wire Digital Diagnostics Clock Interface	See Note 1
C	Rate Select	Open or Low = 1.063 Gb/s or 2.125 Gb/s Fibre Channel, (Low Bandwidth) High = 2.125 or 4.25 Gb/s Fibre Channel (High Bandwidth)	LVTTTL See Note 2
D	Reserved		NA

Notes:

- Should be pulled up with 4.7k – 10kohms on host board to a voltage between 2.0V and V_{CC}.
- For Rate Selectable version only:** In accordance with SFF Committee SFF-8079 Draft Rev. 1.6, Table 3. Note that rate select can also be set through 2-wire bus in accordance with SFF-8472⁵ at Bit 3, Byte 110, Address A2h (note: writing '1' selects full bandwidth operation). Rate select is the logic OR of the input state of Rate Select Pin and 2-wire bus. Non Rate Selectable version can operate at 1x, 2x, 4x Fibre Channel independent of rate select pin setting.

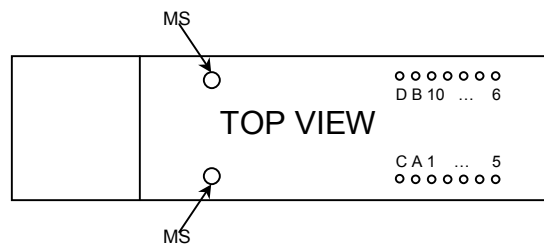

II. Absolute Maximum Ratings

Parameter	Symbol	Min	Typ	Max	Unit	Ref.
Maximum Supply Voltage	V _{CC}	-0.5		4.0	V	
Storage Temperature	T _S	-40		85	°C	
Case Operating Temperature	T _{OP}	-10		85	°C	
Relative Humidity	RH	0		85	%	1
Hand Lead Soldering Temperature/Time				260/10	°C/s	
Wave Lead Soldering Temperature/Time				260/10	°C/s	

Notes:

1. Non condensing.

III. Electrical Characteristics (T_{OP} = -10 to 85 °C, V_{CC} = 3.0 to 3.6 Volts)

Parameter	Symbol	Min	Typ	Max	Unit	Ref.
Supply Voltage	V _{CC}	3.0		3.6	V	
Supply Current	I _{CC}		180	240	mA	
Transmitter						
Input differential impedance	R _{in}	80	100	120	Ω	1
Single ended data input swing	V _{in,pp}	250		1200	mV	
Transmit Disable Voltage	V _D	2		V _{CC}	V	
Transmit Enable Voltage	V _{EN}	V _{EE}		V _{EE} + 0.8	V	2
Receiver						
Output differential impedance	R _{out}	80	100	120	Ω	1
Single ended data output swing	V _{out,pp}	250	350	550	mV	3
Data output rise/fall time	t _r / t _f			120	ps	4
Mask Margin ≤ 2.125 Gb/s			45%			
Signal Detect Normal	SD _{normal}			V _{CC,HOST}	V	5
Signal Detect Fault	SD _{fault}	V _{EE}		V _{EE} +0.5	V	5
Power Supply Rejection	PSR			100	mVpp	6
Deterministic Jitter Contribution @ 2.125 Gb/s	RX Δ DJ			51.7	ps	7
Deterministic Jitter Contribution @ 4.25 Gb/s	RX Δ DJ			23.5	ps	7
Total Jitter Contribution (p-p) @ 2.125 Gb/s	RX Δ TJ			122.4	ps	8
Total Jitter Contribution (p-p) @ 4.25 Gb/s	RX Δ TJ			61	ps	8

Notes:

1. AC coupled.
2. Or open circuit.
3. Into 100 Ω differential termination. Data pattern is PRBS 2⁷-1.
4. 20 – 80 %.
5. Signal detect is LVTTTL. Logic 1 indicates normal operation; logic 0 indicates no signal detected.
6. All transceiver specifications are compliant with a power supply sinusoidal modulation of 20 Hz to 1.5 MHz up to specified value applied through the power supply filtering network shown on page 23 of the Small Form-factor Pluggable (SFP) Transceiver MultiSource Agreement (MSA), September 14, 2000.
7. Measured with DJ-free data input signal. In actual application, output DJ will be the sum of input DJ and Δ DJ, 10⁻¹² BER.
8. If measured with TJ-free data input signal, , 10⁻¹² BER. In actual application, output TJ will be given by:

$$TJ_{OUT} = DJ_{IN} + \Delta DJ + \sqrt{(TJ_{IN} - DJ_{IN})^2 + (\Delta TJ - \Delta DJ)^2}$$

IV. Optical Characteristics (T_{OP} = -10 to 85 °C, V_{CC} = 3.0 to 3.6 Volts)

Parameter	Symbol	Min	Typ	Max	Unit	Ref.
Transmitter						
Output Opt. Pwr: 50 or 62.5 MMF	P _{OUT}	-9		-2.5	dBm	1
Optical Wavelength	λ	830		860	nm	
Spectral Width	σ			0.85	nm	
Optical Modulation Amplitude @ 4.25 Gb/s	OMA	247			μW	2
Optical Modulation Amplitude @ 2.125 Gb/s	OMA	196			μW	2
Optical Modulation Amplitude @ 1.0625 Gb/s	OMA	156			μW	2
Optical Rise/Fall Time	t _r / t _f			90	ps	3
Relative Intensity Noise	RIN			-118	dB/Hz	
Deterministic Jitter Contribution @ 2.125 Gb/s	TX ΔDJ			56.5	ps	4
Deterministic Jitter Contribution @ 4.25 Gb/s	TX ΔDJ			28.2	ps	4
Total Jitter Contribution @ 2.125 Gb/s	TX ΔTJ			119	ps	5
Total Jitter Contribution @ 4.25 Gb/s	TX ΔTJ			56.5	ps	5
Mask Margin ≤ 2.125 Gb/s			45%			
Receiver						
Receiver Sensitivity = 1.0625 Gb/s	R _{XSENS}			-20	dBm	6
Receiver Sensitivity = 2.125 Gb/s	R _{XSENS}			-18	dBm	6
Receiver Sensitivity = 4.25 Gb/s	R _{XSENS}			-15	dBm	6
Stressed RX sens. =1.0625 Gb/s		0.055			mW	8
Stressed RX sens. =2.125 Gb/s		0.096			mW	8
Stressed RX sens. =4.25 Gb/s		0.138			mW	8
Average Received Power	R _{XMAX}			0	dBm	
Receiver Elec. 3 dB cutoff frequency				1500	MHz	9
Receiver Elec. 3 dB cutoff frequency				2500	MHz	10
Optical Center Wavelength	λ _C	770		860	nm	
Return Loss	RL	12			dB	
Signal Detect Normal	SD _{normal}			-20	dBm	
Signal Detect Fault	SD _{fault}	-30			dBm	
Signal Detect Hysteresis		0.5			dB	

Notes:

- Class 1 Laser Safety per FDA/CDRH, EN (IEC) 60825 laser safety regulations.
- Equivalent extinction ratio specification for Fibre Channel. Allows smaller ER at higher average power.
- Unfiltered, 20-80%. Complies with FC 1x and 2x eye mask when filtered.
- Measured with DJ-free data input signal. In actual application, output DJ will be the sum of input DJ and ΔDJ, 10⁻¹² BER.
- If measured with TJ-free data input signal, 10⁻¹² BER. In actual application, output TJ will be given by:

$$TJ_{OUT} = DJ_{IN} + \Delta DJ + \sqrt{(TJ_{IN} - DJ_{IN})^2 + (\Delta TJ - \Delta DJ)^2}$$

- Specifications are for 50 micro-meter or 62.5 micro-meter fiber
- As measured with 9dB extinction ratio.
- Measured with conformance signals defined in FC-PI-2 Rev. 7.0 specifications.
- Rate selectable version in low bandwidth mode.
- Rate selectable version in high bandwidth mode.

V. General Specifications

Parameter	Symbol	Min	Typ	Max	Units	Ref.
Data Rate	BR		1.062, 2.125, 4.25		Gb/sec	1
Bit Error Rate	BER			10 ⁻¹²		5
Fiber Length on 50/125µm MMF	L			550 300 150	m	2 3 4
Fiber Length on 62.5/125µm MMF	L			300 150 70	m	2 3 4

Notes:

- 1x, 2x, and 4x Fibre Channel compatible per FC-PI-2 Rev. 7.0.
- At 1.0625 Gb/s Fibre Channel data rate.
- At 2.125 Gb/s Fibre Channel data rate.
- At 4.25 Gb/s Fibre Channel data rate.
- At 1.0625, 2.125, and 4.25Gb/s with PRBS 2⁷-1.

VI. Environmental Specifications

Finisar SFF transceivers have an extended operating temperature range from –10°C to +85°C case temperature.

Parameter	Symbol	Min	Typ	Max	Units	Ref.
Case Operating Temperature	T _{op}	-10		85	°C	
Storage Temperature	T _{sto}	-40		85	°C	

Notes:

- SFF transceivers may be water washed with the optical port plug in position. However, the process must be followed by a baking step at 80°C for one hour, to ensure the drying of any water which may be trapped inside then shells of the modules.

VII. Regulatory Compliance

Finisar transceivers are Class 1 Laser Products and comply with US FDA regulations. These products are certified by TÜV and CSA to meet the Class 1 eye safety requirements of EN (IEC) 60825 and the electrical safety requirements of EN (IEC) 60950. Copies of certificates are available at Finisar Corporation upon request.

VIII. Digital Diagnostic Functions

Finisar FTLF8524E2xNy 2x7 SFF transceivers support a 2-wire serial communication protocol. This interface is identical to the 2-wire serial interface defined in the SFP MSA⁴, however in this case it is implemented on the 2x7 SFF form factor.

The standard SFP serial ID provides access to identification information that describes the transceiver's capabilities, standard interfaces, manufacturer, and other information.

Additionally, an enhanced digital diagnostic monitoring interface is defined, which allows real-time access to device operating parameters such as transceiver temperature, laser bias current, transmitted optical power, received optical power and transceiver supply voltage. It also defines a sophisticated system of alarm and warning flags, which alerts end-users when particular operating parameters are outside of a factory set normal range.

In order to access the identification information, the 2x7 SFF transceivers have a 256-byte memory map in E²PROM that is accessible over a 2-wire serial interface at the 8 bit address 1010000X (A0h). The digital diagnostic monitoring interface makes use of the 8 bit address 1010001X (A2h), so the originally defined serial ID memory map remains unchanged. The interface is identical to, and is thus fully backward compatible with both the GBIC Specification and the SFP Multi Source Agreement. Additional information, including details of the electronic interface, is described in Finisar Application Note AN-2030: "Digital Diagnostics Monitoring Interface for SFP Optical Transceivers".

The operating and diagnostics information is monitored and reported by a Digital Diagnostics Transceiver Controller (DDTC) inside the transceiver, which is accessed through a 2-wire serial interface. When the serial protocol is activated, the serial clock signal (SCL, Mod Def 1) is generated by the host. The positive edge clocks data into the 2x7 SFF transceiver into those segments of the E²PROM that are not write-protected. The negative edge clocks data from the 2x7 SFF transceiver. The serial data signal (SDA, Mod Def 2) is bi-directional for serial data transfer. The host uses SDA in conjunction with SCL to mark the start and end of serial protocol activation. The memories are organized as a series of 8-bit data words that can be addressed individually or sequentially.

For more information, please see the SFP MSA documentation^{4,5} and Finisar Application Note AN-2030.

One difference in the implementation of digital diagnostics in the SFF 2x7 form factor from the SFP MSA documentation is the readout of Bit 1, Byte 110 at Address A2h (called "Digital State of the LOS output pin" in the SFP documentation). In the SFF 2x7, the output of this bit is inverted to indicate Signal Detect and match the output of the Signal Detect pin on the SFF part.

Digital diagnostics for the FTLF8524E2xNy can be used in host systems that require either internally or externally calibrated digital diagnostics.

IX. Mechanical Specifications

Finisar’s Small Form Factor (SFF) transceivers comply with the standard dimensions defined by the Small Form Factor Multi-Sourcing Agreement (MSA).

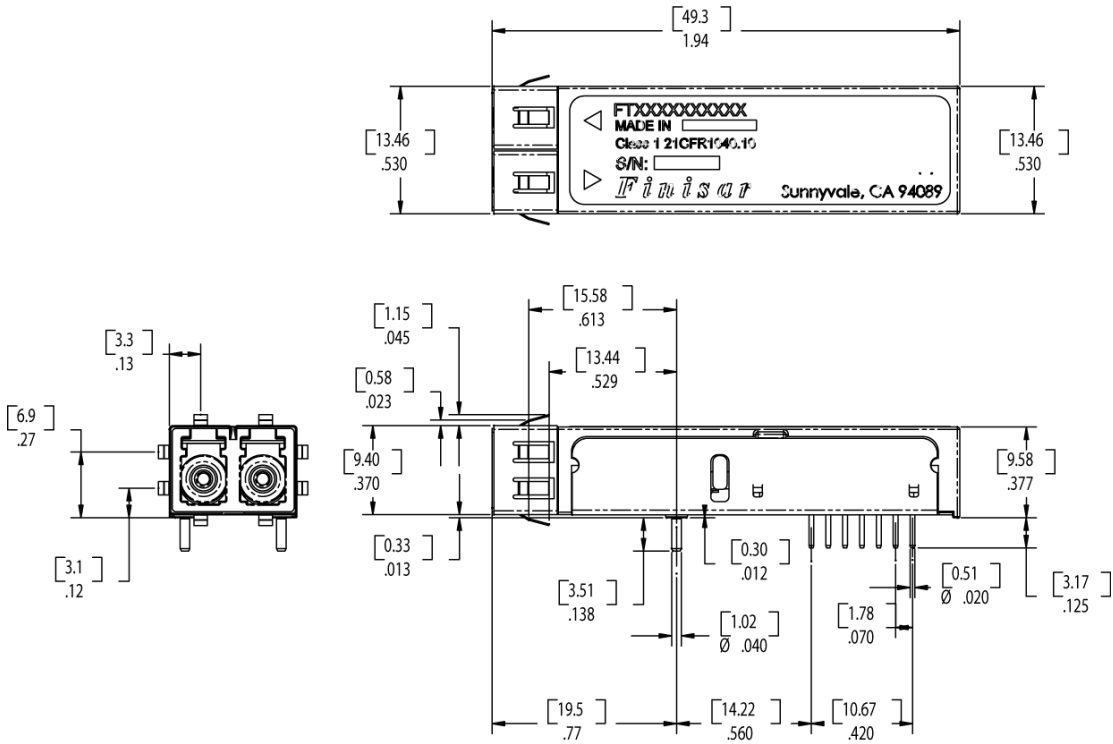

FTLF8524E2GNy

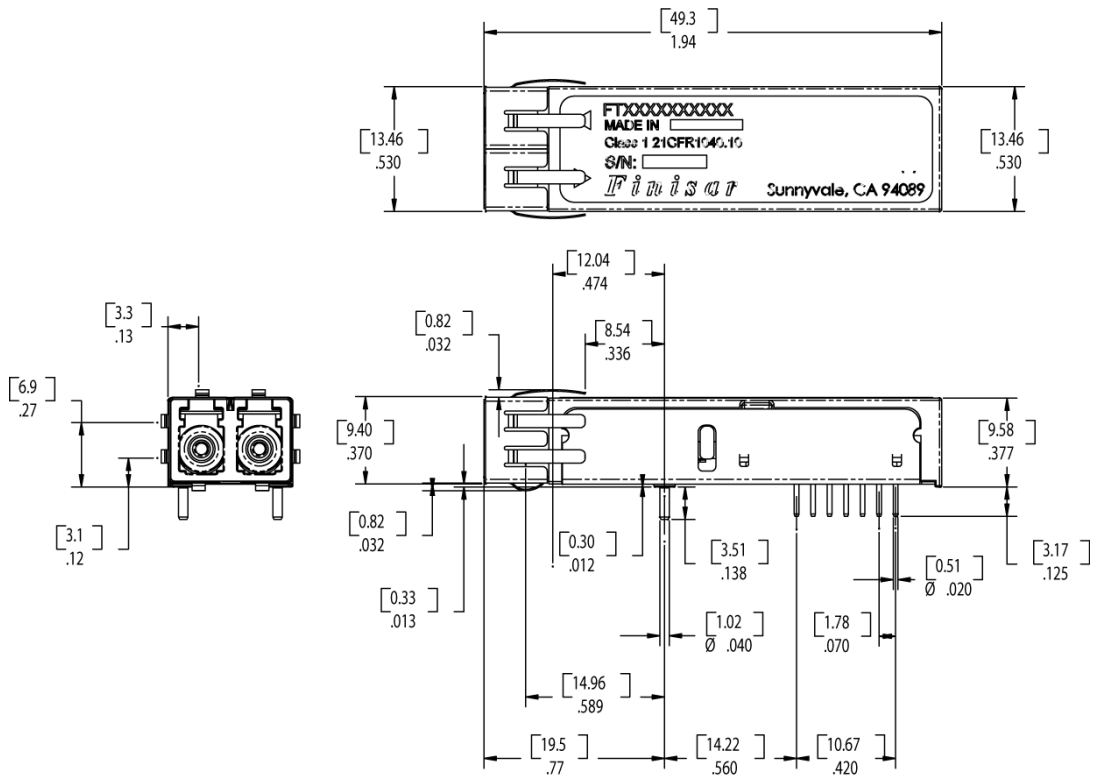

FTLF8524E2KNy

X. PCB Layout and Bezel Recommendations

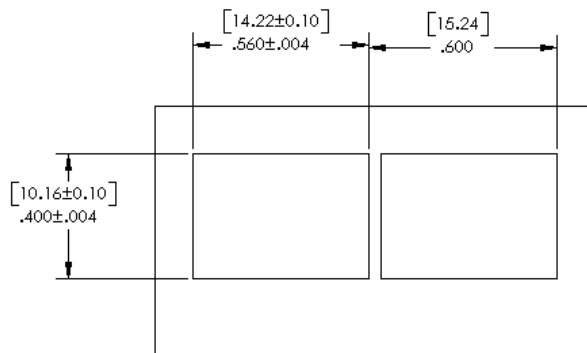
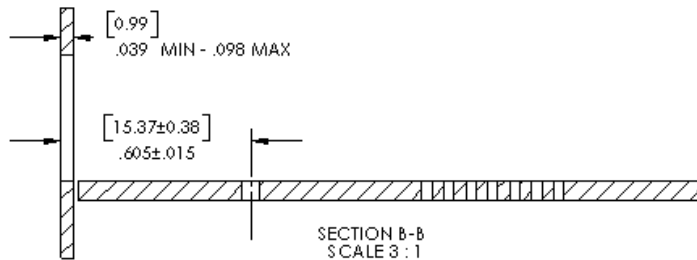
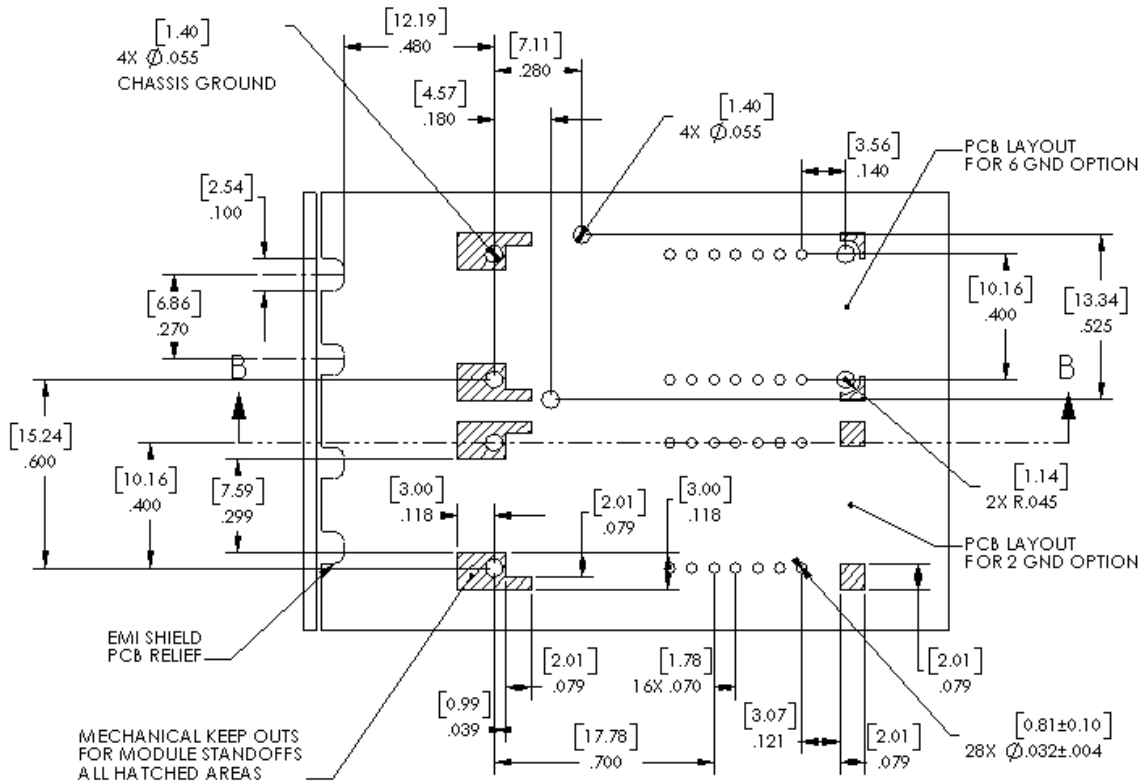

XI. References

1. Small Form Factor (SFF) Transceiver Multi-source Agreement (MSA). July 5, 2000.
2. “Fibre Channel Draft Physical Interface Specification (FC-PI-2 Rev. 7.0)”. American National Standard for Information Systems.
3. Directive 2002/95/EC of the European Council Parliament and of the Council, “on the restriction of the use of certain hazardous substances in electrical and electronic equipment.” January 27, 2003.
4. Small Form-factor Pluggable (SFP) Transceiver Multi-source Agreement (MSA), September 14, 2000.
5. “Digital Diagnostics Monitoring Interface for Optical Transceivers”. SFF Document Number SFF-8472, Revision 9.3.

XII. For More Information

Finisar Corporation
1308 Moffett Park Drive
Sunnyvale, CA 94089-1133
Tel. 1-408-548-1000
Fax 1-408-541-6138
sales@finisar.com
www.finisar.com



Компания «ЭлектроПласт» предлагает заключение долгосрочных отношений при поставках импортных электронных компонентов на взаимовыгодных условиях!

Наши преимущества:

- Оперативные поставки широкого спектра электронных компонентов отечественного и импортного производства напрямую от производителей и с крупнейших мировых складов;
- Поставка более 17-ти миллионов наименований электронных компонентов;
- Поставка сложных, дефицитных, либо снятых с производства позиций;
- Оперативные сроки поставки под заказ (от 5 рабочих дней);
- Экспресс доставка в любую точку России;
- Техническая поддержка проекта, помощь в подборе аналогов, поставка прототипов;
- Система менеджмента качества сертифицирована по Международному стандарту ISO 9001;
- Лицензия ФСБ на осуществление работ с использованием сведений, составляющих государственную тайну;
- Поставка специализированных компонентов (Xilinx, Altera, Analog Devices, Intersil, Interpoint, Microsemi, Aeroflex, Peregrine, Syfer, Eurofarad, Texas Instrument, Miteq, Cobham, E2V, MA-COM, Hittite, Mini-Circuits, General Dynamics и др.);

Помимо этого, одним из направлений компании «ЭлектроПласт» является направление «Источники питания». Мы предлагаем Вам помощь Конструкторского отдела:

- Подбор оптимального решения, техническое обоснование при выборе компонента;
- Подбор аналогов;
- Консультации по применению компонента;
- Поставка образцов и прототипов;
- Техническая поддержка проекта;
- Защита от снятия компонента с производства.



Как с нами связаться

Телефон: 8 (812) 309 58 32 (многоканальный)

Факс: 8 (812) 320-02-42

Электронная почта: org@eplast1.ru

Адрес: 198099, г. Санкт-Петербург, ул. Калинина, дом 2, корпус 4, литера А.