

Printmount Switch, Medium Stroke, 7.5 mm



See below:

Approvals and Compliances

Description

- Available with various actuator colors
- High switching capacity
- Optional retaining bracket

Unique Selling Proposition

- Different contacting materials for different applications
- High life time thanks to high quality materials
- Suitable for PCB mounting

Weblinks

[pdf data sheet](#), [html datasheet](#), [General Product Information](#), [CAD-Drawings](#), [Product News](#), [Detailed request for product](#)

Technical Data

Electrical Data

Switching Voltage	max. 48 VAC/ 48 VDC
Lifetime	> 100'000 actuations at Rated Switching Capacity
Insulation Resistance	> 1000 MΩ

Contact Material Silver

Switching Current	AC: 2 A / DC: 1.2 A
Contact Resistance	< 10mΩ

Contact Material Gold

Switching Current	80 mA
Contact Resistance	< 20 mΩ

Mechanical Data

Actuating Force	3 - 5 N
Actuating Travel	2.4 ± 0.3 mm
End Actuating Travel	3.3 ± 0.4 mm
End Stop Strength	> 100 N
Lifetime	> 200'000 actuations

Climatical Data

Operating Temperature	-40 °C - 85 °C
Storage Temperature	-40 °C - 85 °C
IP-Protection	IP40

Other Data

Contact Material	Ag / Au
------------------	---------

Soldering Data

Solderability	235 °C / 2 sec (IEC 60068-2-20 Test Ta Method 1A)
Resistance to Soldering Heat	260 °C / 5 sec (IEC 60068-2-20 Test Tb Method 1)

Material

Socket	Thermoplastic (PC)
Button	Thermoplastic (PC)
Contact	gold (2µm Au on hard silver)

Approvals and Compliances

Detailed information on product approvals, code requirements, usage instructions and detailed test conditions can be looked up in [Details about Approvals](#)

SCHURTER products are designed for use in industrial environments. They have approvals from independent testing bodies according to national and international standards. Products with specific characteristics and requirements such as required in the automotive sector according to IATF 16949, medical technology according to ISO 13485 or in the aerospace industry can be offered exclusively with customer-specific, individual agreements by SCHURTER.



Application standards

Application standards where the product can be used

Organization	Design	Standard	Description
	Designed for applications acc.	IEC/UL 62368-1	IEC 62368-1 includes the basic requirements for safety of audio, video, information technology and office equipment.

Compliances

The product complies with following Guide Lines

Identification	Details	Initiator	Description
	RoHS	SCHURTER AG	Directive RoHS 2011/65/EU, Amendment (EU) 2015/863
	China RoHS	SCHURTER AG	The law SJ / T 11363-2006 (China RoHS) has been in force since 1 March 2007. It is similar to the EU directive RoHS.
	REACH	SCHURTER AG	On 1 June 2007, Regulation (EC) No 1907/2006 on the Registration, Evaluation, Authorization and Restriction of Chemicals 1 (abbreviated as "REACH") entered into force.

Dimension [mm]

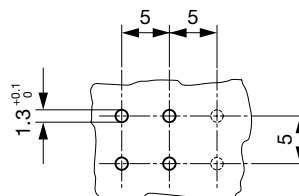
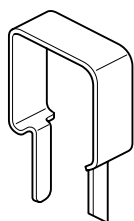
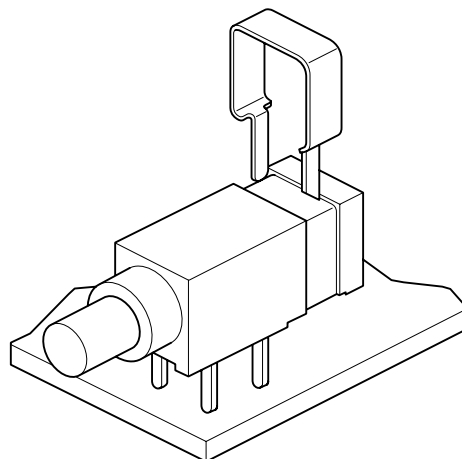
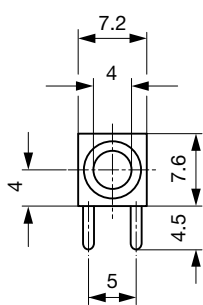
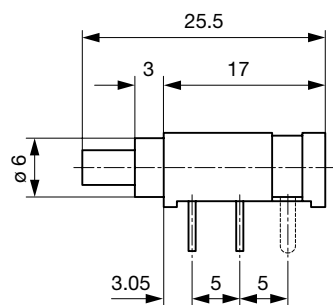

The optional retaining bracket has to be ordered separately

Drilling diagram

Diagrams

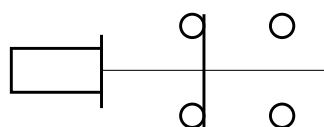

All Variants

Designation	Kontakte	Color Button	Bestellnummer
SDK SWITCH 0+S SW	Ag	black	0041.0401
SDK SWITCH 0+S RT	Ag	red	0041.0402
SDK SWITCH 0+S GN	Ag	green	0041.0403
SDK SWITCH 0+S SW	Au	black	0041.0411
SDK SWITCH 0+S RT	Au	red	0041.0412
SDK SWITCH 0+S GN	Au	green	0041.0413
RETAINING BRACKET SDK	-	-	0701.0049

Most Popular.

Availability for all products can be searched real-time:<https://www.schurter.com/en/Stock-Check/Stock-Check-SCHURTER>

Packaging unit 100 pcs



Компания «ЭлектроПласт» предлагает заключение долгосрочных отношений при поставках импортных электронных компонентов на взаимовыгодных условиях!

Наши преимущества:

- Оперативные поставки широкого спектра электронных компонентов отечественного и импортного производства напрямую от производителей и с крупнейших мировых складов;
- Поставка более 17-ти миллионов наименований электронных компонентов;
- Поставка сложных, дефицитных, либо снятых с производства позиций;
- Оперативные сроки поставки под заказ (от 5 рабочих дней);
- Экспресс доставка в любую точку России;
- Техническая поддержка проекта, помощь в подборе аналогов, поставка прототипов;
- Система менеджмента качества сертифицирована по Международному стандарту ISO 9001;
- Лицензия ФСБ на осуществление работ с использованием сведений, составляющих государственную тайну;
- Поставка специализированных компонентов (Xilinx, Altera, Analog Devices, Intersil, Interpoint, Microsemi, Aeroflex, Peregrine, Syfer, Eurofarad, Texas Instrument, Miteq, Cobham, E2V, MA-COM, Hittite, Mini-Circuits, General Dynamics и др.);

Помимо этого, одним из направлений компании «ЭлектроПласт» является направление «Источники питания». Мы предлагаем Вам помощь Конструкторского отдела:

- Подбор оптимального решения, техническое обоснование при выборе компонента;
- Подбор аналогов;
- Консультации по применению компонента;
- Поставка образцов и прототипов;
- Техническая поддержка проекта;
- Защита от снятия компонента с производства.



Как с нами связаться

Телефон: 8 (812) 309 58 32 (многоканальный)

Факс: 8 (812) 320-02-42

Электронная почта: org@eplast1.ru

Адрес: 198099, г. Санкт-Петербург, ул. Калинина, дом 2, корпус 4, литера А.