

**DATA SHEET**

# SKY65971-11: 2 GHz, 256 QAM Low-Noise Amplifier

## Applications

- 256 QAM, 802.11g/n WLANs
- 2 GHz ISM radios
- Smart phones
- Notebooks, netbooks, tablets
- Access points, routers, gateways
- Wireless video systems

## Features

- Ultra-low Noise Figure
- 2.4 GHz to 2.5 GHz operation
- Enable/disable/bypass modes
- High IIP3
- High gain
- 2.8 V to 3.6 V single-supply operation
- QFN (6-pin, 1.5 x 1.5 mm) package (MSL1, 260 °C per JEDEC J-STD-020)



Skyworks Pb-free products are compliant with all applicable legislation. For additional information, refer to *Skyworks Definition of Lead (Pb)-Free*, document number SQ04-0073.

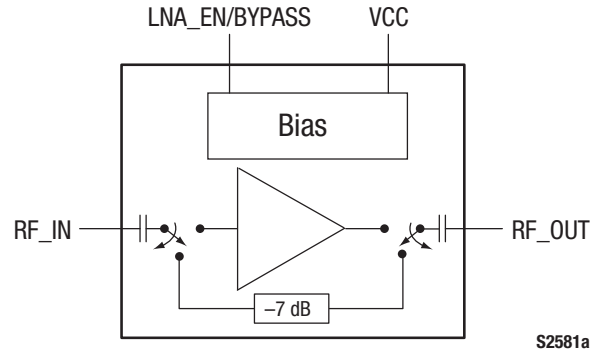

**Figure 1. SKY65971-11 LNA Block Diagram**

## Description

The SKY65971-11 is an ultra Low-Noise Amplifier (LNA) intended for 2 GHz, 256 Quadrature Amplitude Modulation (QAM) wireless receiver applications. Its industry-leading Noise Figure (NF), together with high linearity, make it ideal as a first-stage LNA in 256 QAM Wireless Local Area Network (WLAN) radios.

Operating with a single supply voltage, the SKY65971-11 consumes only 13 mA of current. The device includes a bypass mode for near field applications and to save power when the receiver is inactive.

The tiny package footprint of the SKY65971-11, requiring only four external components, enables the industry's smallest PCB area needed to implement a 2 GHz LNA.

A block diagram of the SKY65971-11 is shown in Figure 1. The device package and pinout for the 6-pin Quad Flat No-Lead (QFN) are shown in Figure 2.

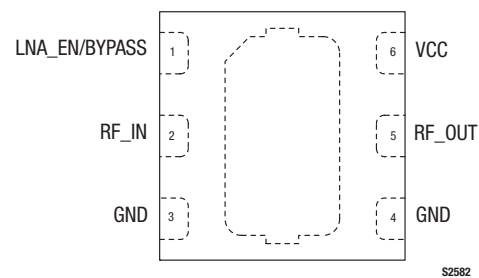

**Figure 2. SKY65971-11 Pinout – 6-Pin QFN Package (Top View)**

### Technical Description

The SKY65971-11 is fully matched at 50 Ω and requires only a simple bypass circuit on pin 6 (VCC). The bypass/shutdown mode is achieved by switching the LNA\_EN signal (pin 1) to 0 V.

### Package and Handling Information

Instructions on the shipping container label regarding exposure to moisture after the container seal is broken must be followed. Otherwise, problems related to moisture absorption may occur when the part is subjected to high temperature during solder assembly.

The SKY65971-11 is rated to Moisture Sensitivity Level 1 (MSL1) at 260 °C. It can be used for lead or lead-free soldering. For additional information, refer to the Skyworks Application Note, *Solder Reflow Information*, document number 200164.

Care must be taken when attaching this product, whether it is done manually or in a production solder reflow environment.

Production quantities of this product are shipped in a standard tape and reel format.

### Electrical and Mechanical Specifications

Signal pin assignments and functional pin descriptions are described in Table 1. The absolute maximum ratings of the SKY65971-11 are provided in Table 2. The recommended operating conditions are specified in Table 3 and electrical specifications are provided in Table 4.

Performance characteristics for the SKY65971-11 are illustrated in Figures 3 through 8.

An application schematic diagram for the SKY65971-11 is shown in Figure 9. The PCB footprint drawing for the SKY65971-11 is provided in Figure 10. Typical part markings are shown in Figure 11. The package dimensions for the 6-pin QFN are shown in Figure 12, and the tape and reel dimensions are provided in Figure 13.

**Table 1. SKY65971-11 Pin Assignments and Signal Descriptions**

Pin	Name	Description
1	LNA_EN/BYPASS	LNA enable (when pulled high) or bypass (when pulled low) control input
2	RF_IN	LNA RF input
3	GND	Ground
4	GND	Ground
5	RF_OUT	LNA RF output
6	VCC	Supply voltage for LNA

**Table 2. Absolute Maximum Ratings (Note 1)**

Parameter	Symbol	Minimum	Maximum	Units
Supply voltage	VCC	0	3.6	V
DC voltage at control ports	VENABLE	0	3.6	V
Power into LNA inputs	P <sub>IN</sub> , LNA		+10	dBm
Receive power (ANT terminated in 50 Ω match, OFDM, V <sub>CC</sub> = 3.45 V)	P <sub>IN</sub>		+5	dBm
Operating temperature	T <sub>A</sub>	-40	+85	°C
Storage temperature	T <sub>STG</sub>	-40	+125	°C
Electrostatic Discharge, Human Body Model (HBM), Class 1C	ESD		1000	V

**Note 1:** Exposure to maximum rating conditions for extended periods may reduce device reliability. There is no damage to device with only one parameter set at the limit and all other parameters set at or below their nominal values. Exceeding any of the limits listed here may result in permanent damage to the device.

**CAUTION:** Although this device is designed to be as robust as possible, Electrostatic Discharge (ESD) can damage this device. This device must be protected at all times from ESD. Static charges may easily produce potentials of several kilovolts on the human body or equipment, which can discharge without detection. Industry-standard ESD precautions should be used at all times.

**Table 3. Recommended Operating Conditions (@ +25 °C, VCC = 3.3 V)**

Parameter	Symbol	Minimum	Typical	Maximum	Units
Supply voltage	VCC	0		3.6	V
RF frequency range	f	2.4		2.5	GHz
Operating temperature range	TA	-40		+85	°C
DC voltage at control port:					
High	VENABLE_H	1.8		3.6	V
Low	VENABLE_L	0		0.2	V

**Table 4. Electrical Characteristics (Note 1)****(VCC = 3.3 V, TA = +25 °C, f = 2.4 to 2.5 GHz, VENABLE = 3.3 V, Unless Otherwise Noted)**

Parameter	Symbol	Test Conditions	Minimum	Typical	Maximum	Units
<b>Enable Mode (LNA_EN = 3.3 V)</b>						
Gain	IS211		13.0	14.5		dB
Gain flatness across band	IS211			0.3		
Out of band gain @ 5.18 GHz	S21_5.18			-8		dB
Noise Figure	NF			1.3	1.5	dB
3 <sup>rd</sup> Order Input Intercept Point	IIP3			+7		dBm
In-band 1 dB compression point at input	IP1dB			-1.5		dBm
Out-of-band (5.18 GHz injected signal) 1 dB Input Compression Point	IP1dB			+4		dBm
Input return loss	IS111	Zs/L = 50 Ω	9			dB
Output return loss	IS221	Zs/L = 50 Ω	12			dB
Reverse isolation	S12			-20		dB
Maximum RF input (compliant)				-10		dBm
Maximum RF input (no damage)				+10		dBm
Drain current				13.0	17.5	mA
Control enable current	IEN				100	μA
<b>Bypass Mode (LNA_EN = 0 V)</b>						
Gain	S21			-7		dB
Gain flatness across 80 MHz	IS211			0.5		dB
Noise Figure	NF			7		dB
1 dB Input Compression Point	IP1dB			+15.3		dBm
Input return loss	IS111		9			dB
Output return loss	IS221		12			dB
Maximum RF input with harmonic < -50 dBm/MHz (Note 2)				+6		dBm
Switching speed: LNA to bypass mode and bypass mode to LNA	ts				300	ns

**Note 1:** Performance is guaranteed only under the conditions listed in this Table.**Note 2:** Harmonic leakage is measured at the RF\_IN port.

### Typical Performance Characteristics

( $V_{CC} = 3.3\text{ V}$ ,  $T_A = +25\text{ }^\circ\text{C}$ ,  $f = 2.4\text{ to }2.5\text{ GHz}$ ,  $V_{ENABLE} = 3.3\text{ V}$ , Unless Otherwise Noted)

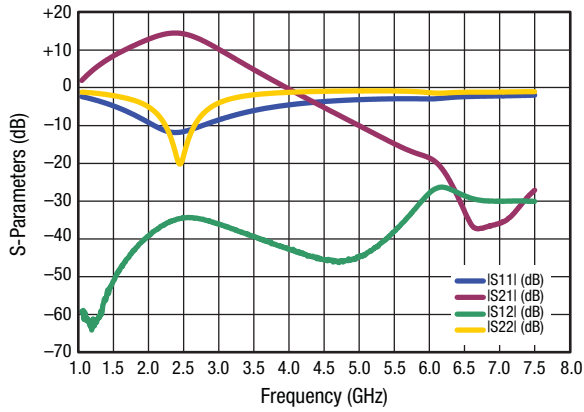

Figure 3. Broadband S-Parameters vs Frequency (“On” State)

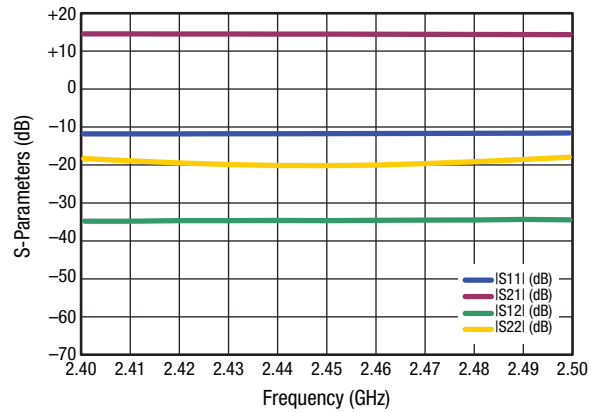

Figure 4. Narrow Band S-Parameters vs Frequency (“On” State)

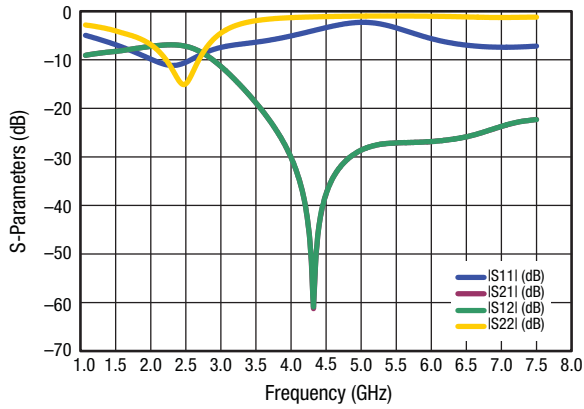

Figure 5. Broadband S-Parameters vs Frequency (“Off” State)

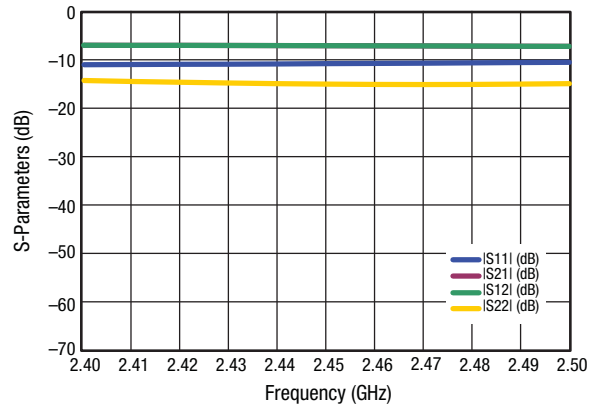

Figure 6. Narrow Band S-Parameters vs Frequency (“Off” State)

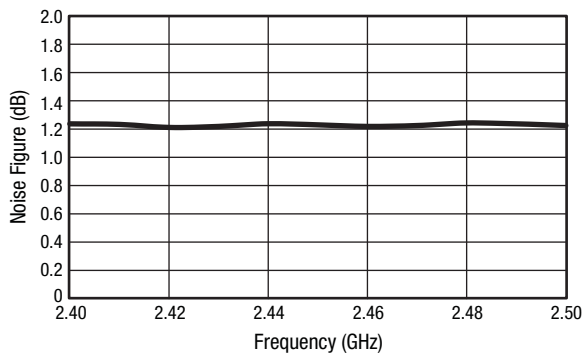

Figure 7. Noise Figure vs Frequency

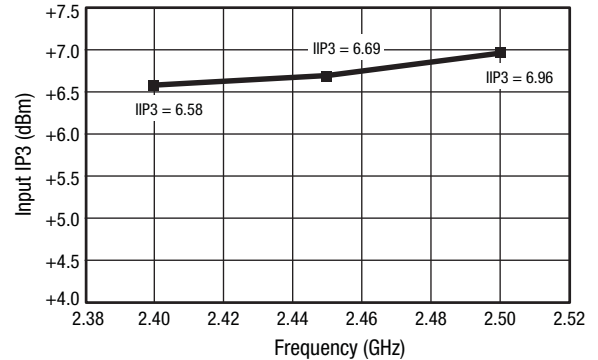
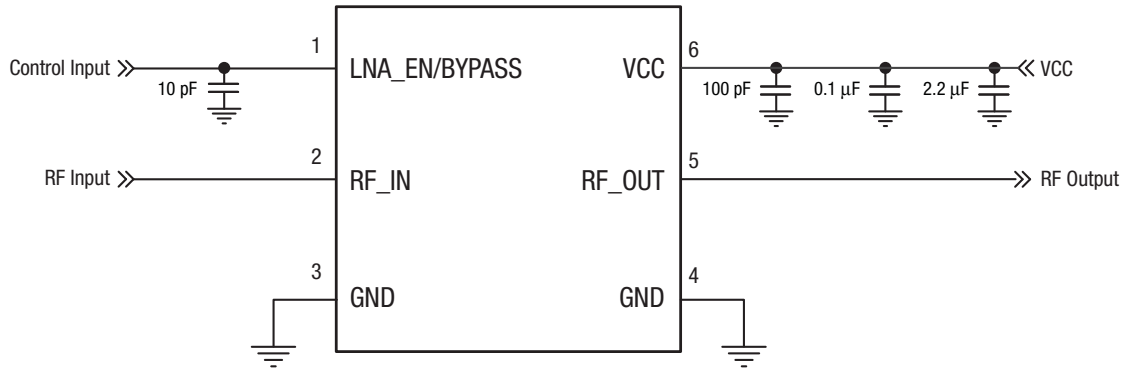
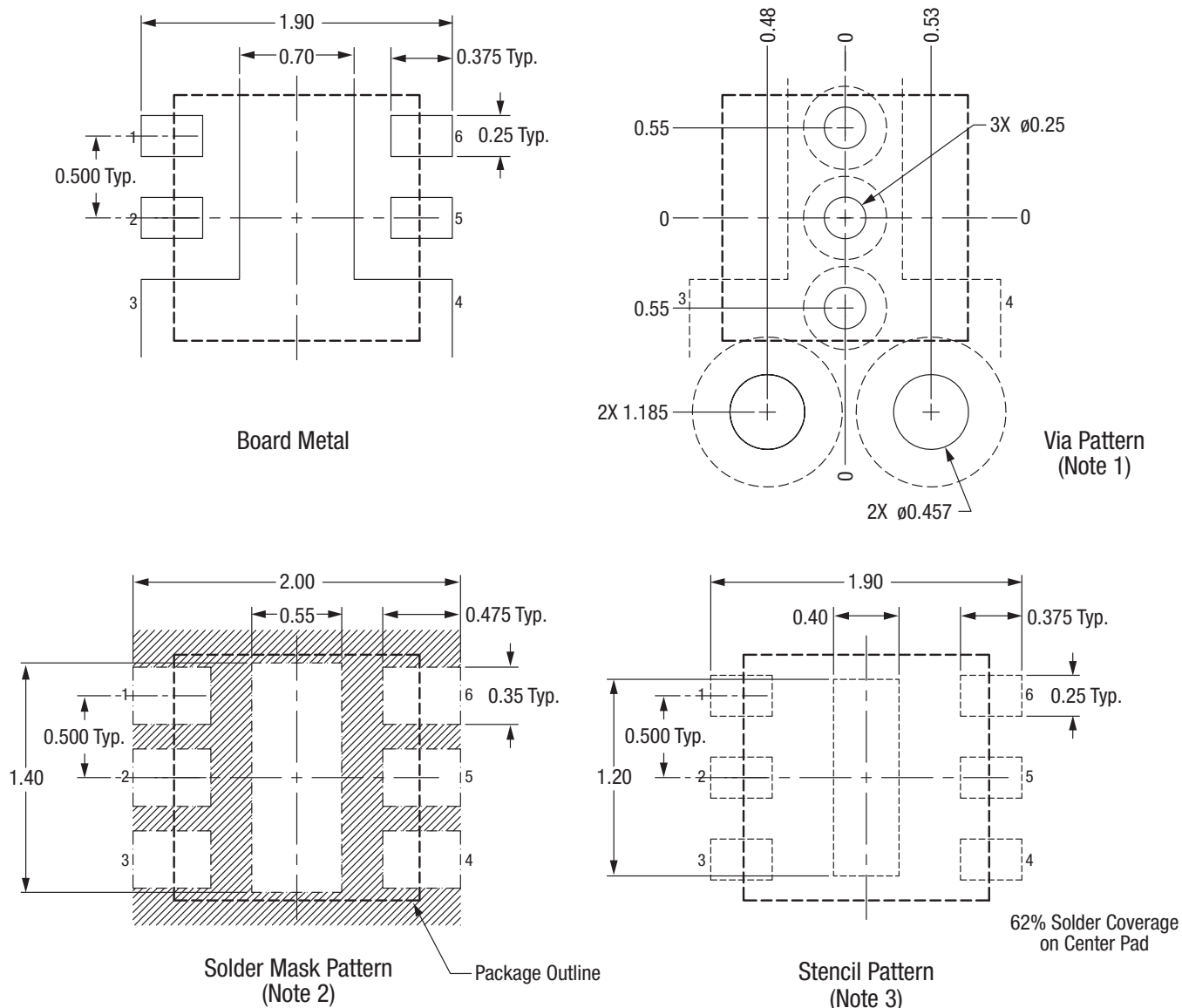

Figure 8. IIP3 vs Frequency



S2672

**Figure 9. SKY65971-11 Schematic Diagram**



NOTES:

1. Via hole recommendations:  
0.025 mm Cu via wall plating (minimum),  
via holes to be plated shut or plugged and  
capped, both sides.
2. Soldermask recommendations:  
Contact board fabricator for recommended  
soldermask offset and tolerance.
3. Stencil recommendations:  
0.10 mm stencil thickness, laser cut apertures,  
trapezoidal walls and rounded corners offer  
better paste release.

Dimension and tolerancing according to ASME Y14.5M-1994.  
Unless specified, dimensions are symmetrical about center lines.  
All dimensions are in millimeters.

S3352

Figure 10. SKY65971-11 PCB Layout Footprint  
(Top View)

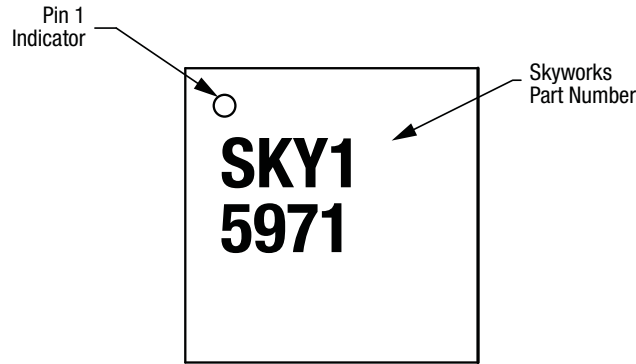

**Figure 11. Typical Part Markings (Top View)**

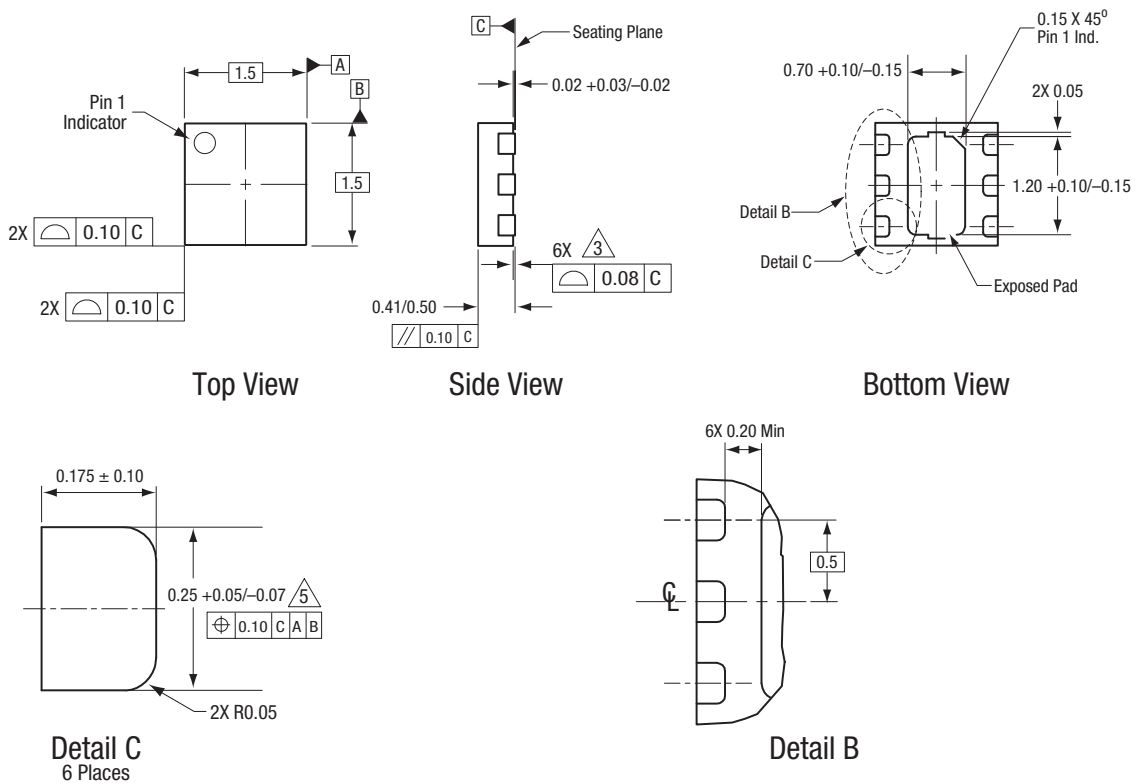

All measurements are in millimeters.  
 Dimensioning and tolerancing according to ASME Y14.5M-1994.  
 Coplanarity applies to the exposed heat sink slug as well as the terminals.  
 Plating requirement per source control drawing (SCD) 2504.  
 Dimension applies to metallized terminal and is measured between 0.15 mm and 0.30 mm from terminal tip.

S1350

**Figure 12. SKY65971-11 6-Pin QFN Package Dimensions**

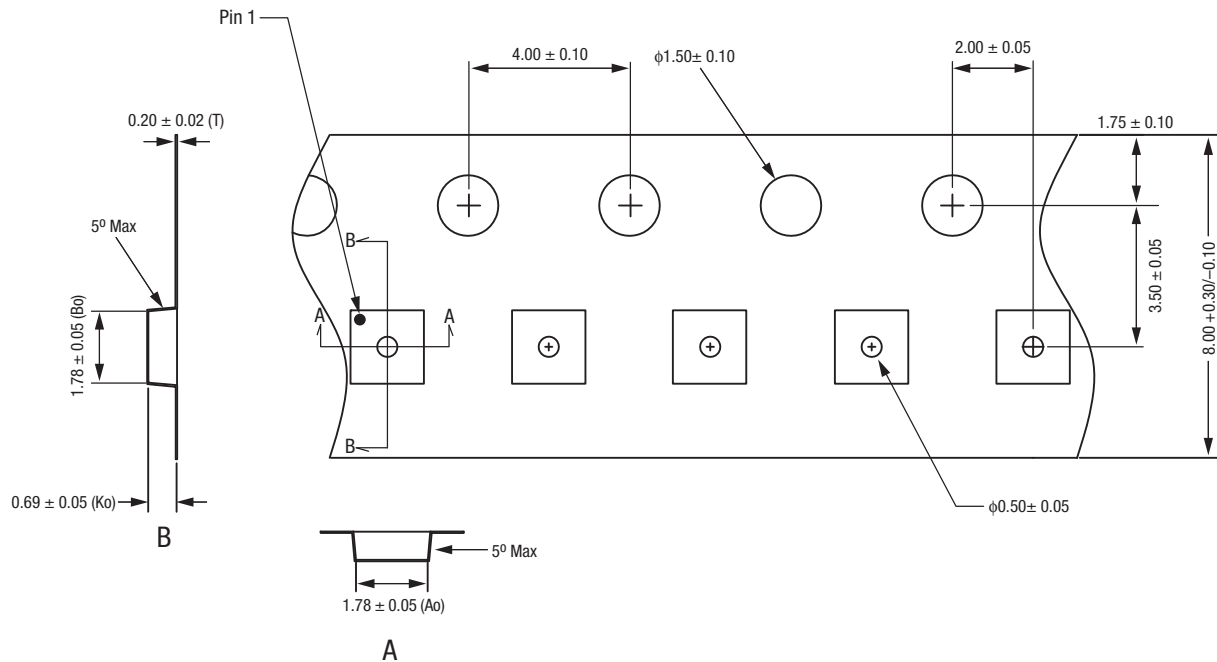

Notes:

1. Carrier tape: black conductive polycarbonate or polystyrene.
2. Cover tape material: transparent conductive PSA.
3. Cover tape size: 5.4 mm width.
4. All measurements are in millimeters.

S1382a

Figure 13. SKY65971-11 Tape and Reel Dimensions



## Ordering Information

Model Name	Manufacturing Part Number	Evaluation Board Part Number
SKY65971-11 2 GHz, 256 QAM LNA	SKY65971-11	SKY65971-11-EK1

Copyright © 2011-2014 Skyworks Solutions, Inc. All Rights Reserved.

Information in this document is provided in connection with Skyworks Solutions, Inc. ("Skyworks") products or services. These materials, including the information contained herein, are provided by Skyworks as a service to its customers and may be used for informational purposes only by the customer. Skyworks assumes no responsibility for errors or omissions in these materials or the information contained herein. Skyworks may change its documentation, products, services, specifications or product descriptions at any time, without notice. Skyworks makes no commitment to update the materials or information and shall have no responsibility whatsoever for conflicts, incompatibilities, or other difficulties arising from any future changes.

No license, whether express, implied, by estoppel or otherwise, is granted to any intellectual property rights by this document. Skyworks assumes no liability for any materials, products or information provided hereunder, including the sale, distribution, reproduction or use of Skyworks products, information or materials, except as may be provided in Skyworks Terms and Conditions of Sale.

THE MATERIALS, PRODUCTS AND INFORMATION ARE PROVIDED "AS IS" WITHOUT WARRANTY OF ANY KIND, WHETHER EXPRESS, IMPLIED, STATUTORY, OR OTHERWISE, INCLUDING FITNESS FOR A PARTICULAR PURPOSE OR USE, MERCHANTABILITY, PERFORMANCE, QUALITY OR NON-INFRINGEMENT OF ANY INTELLECTUAL PROPERTY RIGHT; ALL SUCH WARRANTIES ARE HEREBY EXPRESSLY DISCLAIMED. SKYWORKS DOES NOT WARRANT THE ACCURACY OR COMPLETENESS OF THE INFORMATION, TEXT, GRAPHICS OR OTHER ITEMS CONTAINED WITHIN THESE MATERIALS. SKYWORKS SHALL NOT BE LIABLE FOR ANY DAMAGES, INCLUDING BUT NOT LIMITED TO ANY SPECIAL, INDIRECT, INCIDENTAL, STATUTORY, OR CONSEQUENTIAL DAMAGES, INCLUDING WITHOUT LIMITATION, LOST REVENUES OR LOST PROFITS THAT MAY RESULT FROM THE USE OF THE MATERIALS OR INFORMATION, WHETHER OR NOT THE RECIPIENT OF MATERIALS HAS BEEN ADVISED OF THE POSSIBILITY OF SUCH DAMAGE.

Skyworks products are not intended for use in medical, lifesaving or life-sustaining applications, or other equipment in which the failure of the Skyworks products could lead to personal injury, death, physical or environmental damage. Skyworks customers using or selling Skyworks products for use in such applications do so at their own risk and agree to fully indemnify Skyworks for any damages resulting from such improper use or sale.

Customers are responsible for their products and applications using Skyworks products, which may deviate from published specifications as a result of design defects, errors, or operation of products outside of published parameters or design specifications. Customers should include design and operating safeguards to minimize these and other risks. Skyworks assumes no liability for applications assistance, customer product design, or damage to any equipment resulting from the use of Skyworks products outside of stated published specifications or parameters.

Skyworks, the Skyworks symbol, and "Breakthrough Simplicity" are trademarks or registered trademarks of Skyworks Solutions, Inc., in the United States and other countries. Third-party brands and names are for identification purposes only, and are the property of their respective owners. Additional information, including relevant terms and conditions, posted at [www.skyworksinc.com](http://www.skyworksinc.com), are incorporated by reference.



Компания «ЭлектроПласт» предлагает заключение долгосрочных отношений при поставках импортных электронных компонентов на взаимовыгодных условиях!

Наши преимущества:

- Оперативные поставки широкого спектра электронных компонентов отечественного и импортного производства напрямую от производителей и с крупнейших мировых складов;
- Поставка более 17-ти миллионов наименований электронных компонентов;
- Поставка сложных, дефицитных, либо снятых с производства позиций;
- Оперативные сроки поставки под заказ (от 5 рабочих дней);
- Экспресс доставка в любую точку России;
- Техническая поддержка проекта, помощь в подборе аналогов, поставка прототипов;
- Система менеджмента качества сертифицирована по Международному стандарту ISO 9001;
- Лицензия ФСБ на осуществление работ с использованием сведений, составляющих государственную тайну;
- Поставка специализированных компонентов (Xilinx, Altera, Analog Devices, Intersil, Interpoint, Microsemi, Aeroflex, Peregrine, Syfer, Eurofarad, Texas Instrument, Miteq, Cobham, E2V, MA-COM, Hittite, Mini-Circuits, General Dynamics и др.);

Помимо этого, одним из направлений компании «ЭлектроПласт» является направление «Источники питания». Мы предлагаем Вам помощь Конструкторского отдела:

- Подбор оптимального решения, техническое обоснование при выборе компонента;
- Подбор аналогов;
- Консультации по применению компонента;
- Поставка образцов и прототипов;
- Техническая поддержка проекта;
- Защита от снятия компонента с производства.



#### Как с нами связаться

**Телефон:** 8 (812) 309 58 32 (многоканальный)

**Факс:** 8 (812) 320-02-42

**Электронная почта:** [org@eplast1.ru](mailto:org@eplast1.ru)

**Адрес:** 198099, г. Санкт-Петербург, ул. Калинина, дом 2, корпус 4, литера А.