

SIL40C2 Series

4.5-13.8 Vin Single C-Class Non-Isolated

40 A Current Rating
Input Voltage: 4.5-13.8 V
No. of Outputs: Single



Electrical Specifications

Output

Output voltage	See Note 5	0.6-5 V
Output setpoint accuracy	0.1% trim resistors	±1.0%
Line regulation	Low line to high line	±0.2%
Load regulation	Full load to min. load	±0.5%
Min./max. load		0 A/40 A
Overshoot	At turn-on	0.5% max.
Undershoot	At turn-off	100 mV max.
Ripple and noise 5 Hz to 20 MHz	See Note 1	25 mV Vin=5 V, Vout=2.5 V
Transient response	See Notes 1, 2	130 mV max. deviation 50 μs recovery to within regulation band

Input

Input voltage range		4.5-13.8 Vdc
Input current	Minimum load Remote OFF	50 mA 5 mA
Input current (max.)	See Note 3	25 A @ Io max.
Start-up time	Remote ON/OFF	3 ms

Special Features

- 40 A current rating
- Input voltage range: 4.5-13.8 V
- Output voltage: 0.6-5 V
- Industry leading value
- Cost optimized design
- Excellent transient response
- Output enable
- Output voltage adjustability
- Pathway for future upgrades
- Supports silicon voltage migration
- Resulting in reduced design-in and qual time
- RoHS Compliant

Safety

UL, cUL CAN/CSA 22.2 No.
E139421 UL6950 File No. TBD
TÜV Product Service (EN60950)
Certificate No. TBD
CB report and certificate to
IEC60950

General

Efficiency	Vin=5 V, Vo=2.5 V, Io=20 A	94%
Switching frequency	Fixed	500 kHz
Approvals and standards (pending)		EN60950 UL/cUL6950
Material flammability		UL94V-0
Weight		17 g (0.06 oz.)
MTBF	12 V @ 40 °C, 100% load Bellcore 332	6,749,409 hours
Coplanarity		150 μm

Environmental Specifications

Thermal performance See Note 5	Operating ambient, temperature Non-operating	0 °C to +70 °C -40 °C to +125 °C
-----------------------------------	---	-------------------------------------

Protection

Short-circuit	Hiccup, non-latching
Overvoltage protection	Hiccup, non-latching

Recommended System Capacitance

Input capacitance	See Note 6	0 μF
Output capacitance	See Note 7	0 μF

Ordering Information

Output Power (Max.)	Input Voltage	OVP	Output Voltage	Output Current (Min.)	Output Current (Max.)	Efficiency (Typical)	Regulation Line	Regulation Load	Model Number ^(3,5)
200 W	4.5-13.8 Vdc	N/A	0.6-5 Vdc	0 A	40 A	94%	±0.2%	±0.5%	SIL40C2-00SADJ-VJ
200 W	4.5-13.8 Vdc	N/A	0.6-5 Vdc	0 A	40 A	94%	±0.2%	±0.5%	SIL40C2-00SADJ-HJ
200 W	4.5-13.8 Vdc	N/A	0.6-5 Vdc	0 A	40 A	94%	±0.2%	±0.5%	SMT40C2-00SADJJ

Part Number System with Options

Rev. 07.02.08
SIL40C2
3 of 5

Product Family	Rated Output Current	Performance	Generation	Input Voltage	Output Voltage	Mounting Option	RoHS Compliance ⁽⁸⁾
SIL	40	C	2	00	SADJ	V	J
Product Family SIL = Single In Line SMT = Surface Mount	Rated Output Current 06 = 6 A 15 = 15 A 20 = 20 A 30 = 30 A 40 = 40 A	Performance C = Cost Optimized	Generation Blank = Standard Part 2 = Increased Current Density	Input Voltage 00 = 4.5-13.8 V	Output Voltage Single Adjustable Output	Mounting Option V = Vertical H = Horizontal (Applicable to SIL version only)	RoHS Compliance J = Pb-free RoHS 6/6 Compliant

Output Voltage Adjustment of the SIL40C2 Series

The ultra-wide output voltage trim range offers major advantages to users who select the SIL40C2 series. It is no longer necessary to purchase a variety of modules in order to cover different output voltages. The output voltage can be trimmed in a range of 0.6-5 V. When the SIL40C2 converter leaves the factory, the output has been adjusted to the default voltage of 0.6 V.

Notes:

- 1 Measured as per recommended system capacitance.
- 2 $di/dt = 10 \text{ A}/\mu\text{s}$, $V_{in} = \text{Nom}$, $T_c = 25^\circ\text{C}$, load change = 0.75 I_o to full I_o and full I_o to 0.75.
- 3 External input fusing is recommended.
- 4 Additional part numbers may be available with different output voltages.
- 5 Airflow dependent, 100 LFM minimum required.
- 6 No capacitors needed for ripple current capability.
- 7 No capacitors needed for stability.
- 8 TSE RoHS 5/6 (non-Pb-free) compliant versions are also available on special request, please contact our local sales representative for details.
- 9 NOTICE: Some models may not support all options. Please contact your local representative or use the on-line model number search tool at <http://www.powerconversion.com> to find a suitable alternative.
- 10 To order a Horizontal Mounting option with a pin length of 0.165", please use the model # SIL40C2-00SA-HP5J

Standard Application Drawing

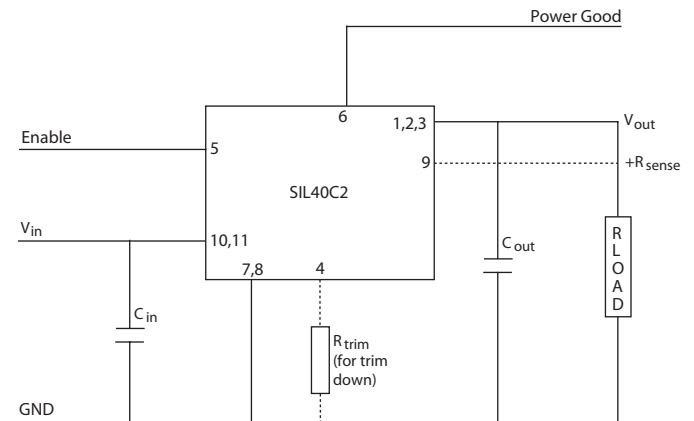

Mechanical Drawings

Dimensions in inches (mm). Tolerances (unless otherwise specified) 2 Places ± 0.030 (± 0.76) 3 Places ± 0.010 (± 0.25)

Vertical Mount

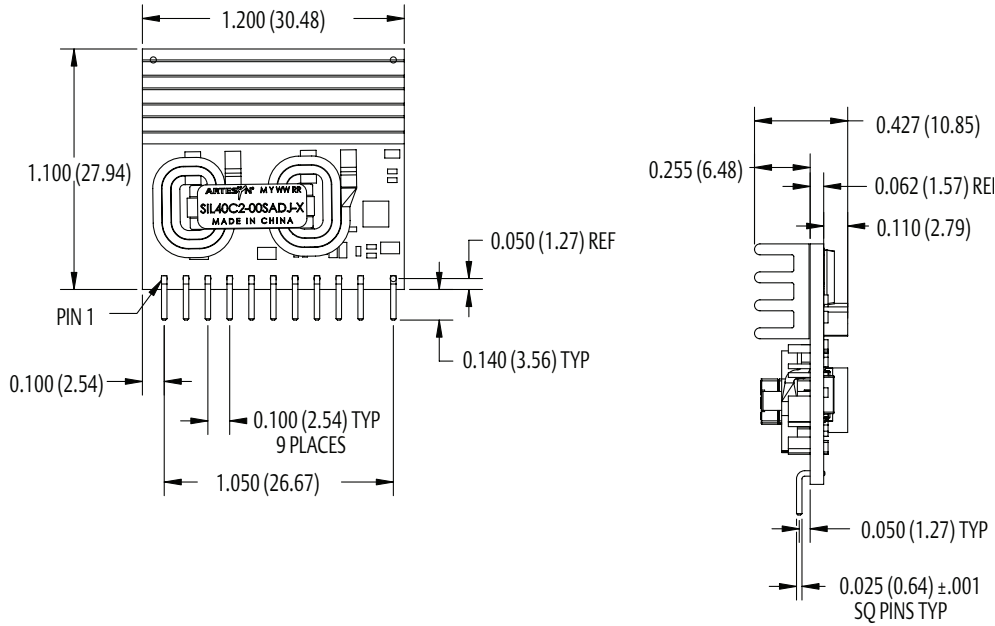

Pin Assignments

Pin No.	Function
1	Vout
2	Vout
3	Vout
4	Trim
5	Enable
6	Power Good
7	Ground
8	Ground
9	(+) Sense
10	Vin
11	Vin
12	*Mech support
13	*Mech support

*Horizontal and SMT version only

Horizontal Mount

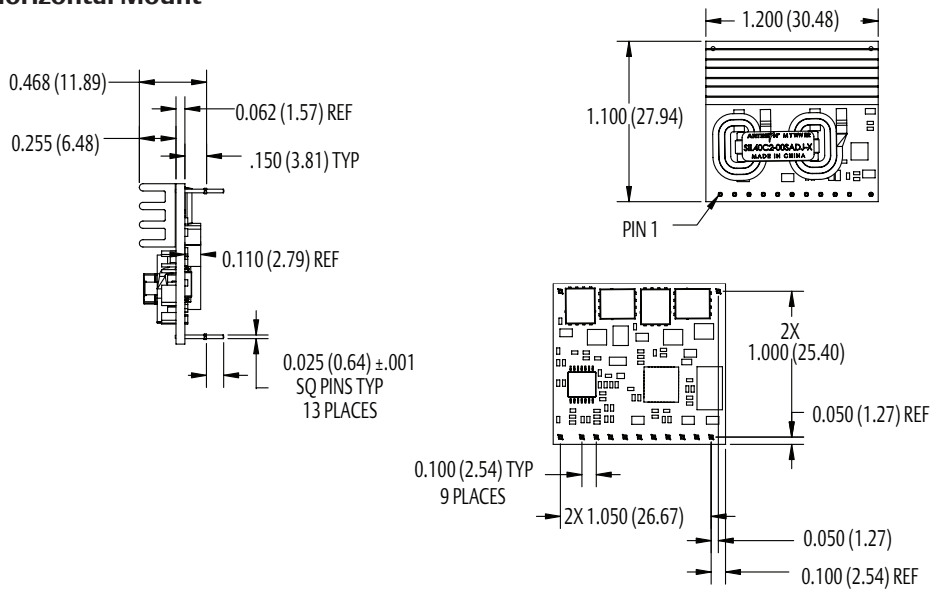

Surface Mount

Dimensions in inches (mm). Tolerances (unless otherwise specified) 2 Places ± 0.030 (± 0.76) 3 Places ± 0.010 (± 0.25)

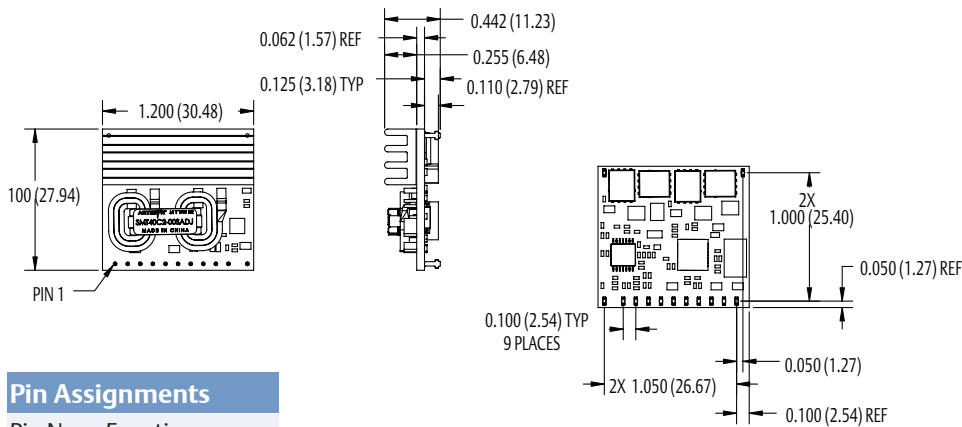

Pin Assignments

Pin No.	Function
1	Vout
2	Vout
3	Vout
4	Trim
5	Enable
6	Power Good
7	Ground
8	Ground
9	(+) Sense
10	Vin
11	Vin
12	*Mech support
13	*Mech support

*Horizontal and SMT version only

Americas

5810 Van Allen Way
Carlsbad, CA 92008
USA
Telephone: +1 (760) 930 4600
Facsimile: +1 (760) 930 0698

Europe (UK)

Waterfront Business Park
Merry Hill, Dudley
West Midlands, DY5 1LX
United Kingdom
Telephone: +44 (0) 1384 842 211
Facsimile: +44 (0) 1384 843 355

Asia (HK)

14/F, Lu Plaza
2 Wing Yip Street
Kwun Tong, Kowloon
Hong Kong
Telephone: +852 2176 3333
Facsimile: +852 2176 3888

For global contact, visit:

www.powerconversion.com

techsupport.embeddedpower@emerson.com

While every precaution has been taken to ensure accuracy and completeness in this literature, Emerson Network Power assumes no responsibility, and disclaims all liability for damages resulting from use of this information or for any errors or omissions.

Emerson Network Power.

The global leader in enabling business-critical continuity.

- AC Power
- Connectivity
- DC Power
- Embedded Computing
- **Embedded Power**
- Monitoring
- Outside Plant
- Power Switching & Controls
- Precision Cooling
- Racks & Integrated Cabinets
- Services
- Surge Protection

EmersonNetworkPower.com

Emerson Network Power and the Emerson Network Power logo are trademarks and service marks of Emerson Electric Co.
©2008 Emerson Electric Co.



Компания «ЭлектроПласт» предлагает заключение долгосрочных отношений при поставках импортных электронных компонентов на взаимовыгодных условиях!

Наши преимущества:

- Оперативные поставки широкого спектра электронных компонентов отечественного и импортного производства напрямую от производителей и с крупнейших мировых складов;
- Поставка более 17-ти миллионов наименований электронных компонентов;
- Поставка сложных, дефицитных, либо снятых с производства позиций;
- Оперативные сроки поставки под заказ (от 5 рабочих дней);
- Экспресс доставка в любую точку России;
- Техническая поддержка проекта, помощь в подборе аналогов, поставка прототипов;
- Система менеджмента качества сертифицирована по Международному стандарту ISO 9001;
- Лицензия ФСБ на осуществление работ с использованием сведений, составляющих государственную тайну;
- Поставка специализированных компонентов (Xilinx, Altera, Analog Devices, Intersil, Interpoint, Microsemi, Aeroflex, Peregrine, Syfer, Eurofarad, Texas Instrument, Miteq, Cobham, E2V, MA-COM, Hittite, Mini-Circuits, General Dynamics и др.);

Помимо этого, одним из направлений компании «ЭлектроПласт» является направление «Источники питания». Мы предлагаем Вам помощь Конструкторского отдела:

- Подбор оптимального решения, техническое обоснование при выборе компонента;
- Подбор аналогов;
- Консультации по применению компонента;
- Поставка образцов и прототипов;
- Техническая поддержка проекта;
- Защита от снятия компонента с производства.



Как с нами связаться

Телефон: 8 (812) 309 58 32 (многоканальный)

Факс: 8 (812) 320-02-42

Электронная почта: org@eplast1.ru

Адрес: 198099, г. Санкт-Петербург, ул. Калинина, дом 2, корпус 4, литера А.