

**PROPER USE GUIDELINES**

Cumulative Trauma Disorders can result from the prolonged use of manually powered hand tools. Hand tools are intended for occasional use and low volume applications. A wide selection of powered application equipment for extended-use, production operations is available.

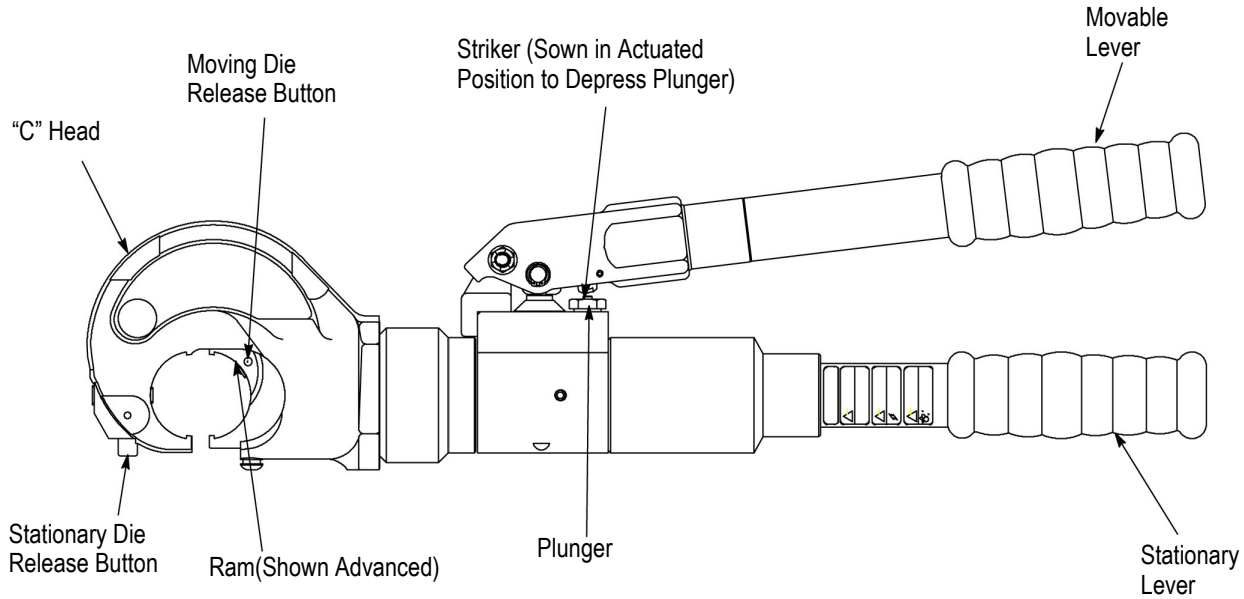

Figure 1

**1. INTRODUCTION**

Hydraulic Hand Crimping Tool 1490748-1 (Figure 1) is designed for crimping the terminals and splices in Figure 2. Read these instructions thoroughly before using the hand tool.

The hand tool has a stationary lever and a movable lever. These levers are compressed to pump hydraulic fluid behind the ram, moving it forward and thereby closing the dies. After the crimping is complete, the movable lever is turned to depress the plunger. The moving die retracts to its original position, completing the crimping cycle.

TERMINALS	WIRE SIZE (AWG)	INSTRUCTION SHEET
AMPOWER* Terminals and Splice	6 Through 3/0	408-8703
SOLISTRAND* Terminals And Splices	8 Through 4/0	408-8691
TERMINYL* Terminals and splices	8 Through 4	408-8704

Figure 2

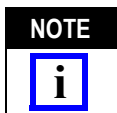

*Dimensions in this instruction sheet are in metric units [with U.S. customary units in brackets].  
Figures and illustrations are for identification only and are not drawn to scale.*

**2. DESCRIPTION**

See Figure 1.

**3. DIE INSERTION AND REMOVAL**



*To avoid damage to the tooling, never operate the tool with the dies removed. Failure to insert the dies before operation can result in damage to the "C"-head or the tool ram.*

1. Advance ram slightly to gain access to moving die release button.
2. Before inserting dies, refer to instruction sheet packaged with dies for detailed instructions: insert or remove dies, as necessary, by following procedures given in the instruction sheet for the dies.

**4. CRIMPING PROCEDURE**

1. Strip wires to dimensions specified on the instructions packaged with dies (see Figure 2).

2. Insert the terminal or splice in stationary die according to instruction sheet packaged with dies.



*To avoid personal injury, be sure to exercise caution while holding terminals, splices, or wire in the crimping area.*

3. Pump movable lever until moving die grips terminal or splice.



*Do not deform wire barrel of terminal or splice.*

4. Insert stripped wire into wire barrel of terminal or splice.

5. Continue pumping movable lever. A slight click may be heard, indicating the pump has shifted into the high-pressure stage. Continue pumping movable lever and completely crimp the connector. This tool has a built-in by-pass cartridge that will automatically activate when full pressure is reached. There will be a noticeable decrease in handle pressure when the by-pass is reached.



*A high pitched squeaking sound is normal when the tool is operating in the high pressure stage,*

6. Turn movable lever (to actuate striker), and compress levers to depress plunger. Movable die will now retract. See Figure 1.

7. Remove the crimped terminal or splice.



*If terminal or splice sticks in die after crimping, apply a rocking action to remove it from die.*

8. Inspect the crimped terminal or splice according to inspection procedure on instruction sheet packaged with the dies.

## 5. MAINTENANCE AND INSPECTION

It is recommended that a maintenance and inspection program be performed periodically to ensure dependable and uniform terminations.

The hand tool is inspected before being shipped; however, It is recommended that the tool be inspected immediately upon arrival at your facility to ensure that the tool has not been damaged during shipment.

## 5.1. Daily Maintenance

1. Immerse the hand tool (levers partially closed) in a reliable commercial degreasing compound to remove accumulated dirt, grease, and foreign matter. When degreasing compound is not available, wipe the tool clean with a soft, lint-free cloth. Do NOT use hard or abrasive objects that could damage the tool.

2. Protect all pins, pivot points, and bearing surfaces with a THIN coat of any good grade SAE‡ 20 motor oil. Do NOT oil excessively.

3. When the tool is not in use, keep the levers closed to prevent objects from becoming lodged in the dies. Store the tool in a clean dry area.

## 5.2. Periodic Inspection

Though recommendations call for at least one inspection a month, actual frequency depends on:

- The care, amount of use, and handling of the hand tool.
- The presence of abnormal amounts of dust and dirt.
- The degree of operator skill, and
- Your own established standards.

### A. Lubrication

Keep all pins, pivot points, and bearing surfaces lubricated with SAE 20 motor oil as follows:

- Tool used in daily production-lubricate daily
- Tool used daily (occasionally)-lubricate weekly
- Tool used weekly-lubricate monthly

Wipe excess oil from tool, particularly from crimping area. Oil transferred from the crimping area onto certain terminations may affect the electrical characteristics of an application.

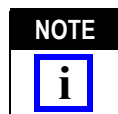

*A slight weeping of oil from the ram and pump seals is normal and required to keep the moving parts lubricated. Excessive leakage indicates a need for seal replacement. Refer to Section 6, RETURN/REPLACEMENT.*

### B. Visual Inspection

1. Make certain all retaining pins are in place and secured with retaining rings. If replacements are necessary, return the tool for repair. See Section 6, RETURN/REPLACEMENT.

2. Inspect for worn, cracked, or broken areas. If damage is evident, return the tool for evaluation and repair as described in Section 6, RETURN/REPLACEMENT.

‡ SAE is a trademark of SAE International Corporation. Society of Automotive Engineering.

**C. Crimping Pressure Inspection**

Check the crimping pressure to ensure that dies are fully bottomed before pressure is reduced by the internal bypass valve. The inspection should be performed using each set of dies that will be used in the tool.

1. Install dies according to Section 3, DIE INSERTION AND REMOVAL, and the instruction sheet packaged with the dies.
2. Select wire and terminal or splice for dies being used.
3. Place terminal or splice in dies according to instruction sheet packaged with dies.
4. Perform crimping procedure as described in Section 4, CRIMPING PROCEDURE, Steps 3 through 5. Do not release hydraulic pressure at this time.
5. Check the clearance between bottoming surfaces of crimping dies. If clearance is 0.025 mm [.001 in.] or less, the crimp pressure is satisfactory. If clearance exceeds 0.025 mm [.001 in.], the crimp pressure is not considered satisfactory. See Section 6, RETURN/REPLACEMENT.

If the tool conforms to these inspection procedures, lubricate it with a THIN coat of any good grade SAE 20 motor oil and return it to service.

**6. RETURN/REPLACEMENT**

Order replacement parts through your Tyco Electronics representative, or call 1-800-526-5142, or send a facsimile of your purchase order to 1-717-986-7605, or write to:

CUSTOMER SERVICE (038-035)  
 TYCO ELECTRONICS CORPORATION  
 PO BOX 3608  
 HARRISBURG PA 17105-3608

Crimping heads may also be returned for evaluation and repair. For tool repair service, contact a Tyco Electronics representative at 1-800-526-5136.

**7. REVISION SUMMARY**

Since the previous release of these instructions, the TE logo was applied.

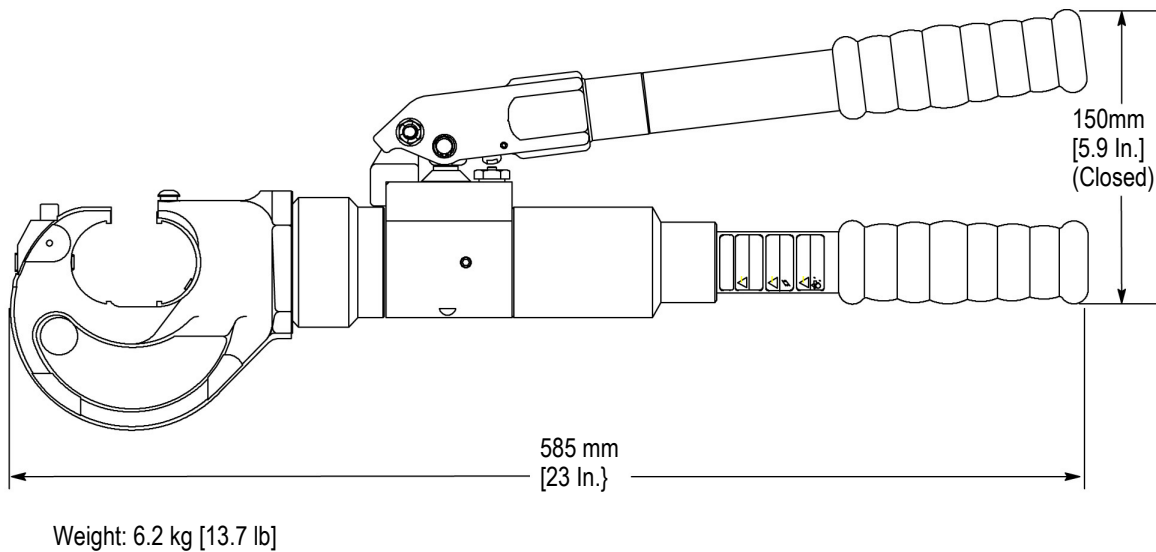

Figure 3



Компания «ЭлектроПласт» предлагает заключение долгосрочных отношений при поставках импортных электронных компонентов на взаимовыгодных условиях!

Наши преимущества:

- Оперативные поставки широкого спектра электронных компонентов отечественного и импортного производства напрямую от производителей и с крупнейших мировых складов;
- Поставка более 17-ти миллионов наименований электронных компонентов;
- Поставка сложных, дефицитных, либо снятых с производства позиций;
- Оперативные сроки поставки под заказ (от 5 рабочих дней);
- Экспресс доставка в любую точку России;
- Техническая поддержка проекта, помощь в подборе аналогов, поставка прототипов;
- Система менеджмента качества сертифицирована по Международному стандарту ISO 9001;
- Лицензия ФСБ на осуществление работ с использованием сведений, составляющих государственную тайну;
- Поставка специализированных компонентов (Xilinx, Altera, Analog Devices, Intersil, Interpoint, Microsemi, Aeroflex, Peregrine, Syfer, Eurofarad, Texas Instrument, Miteq, Cobham, E2V, MA-COM, Hittite, Mini-Circuits, General Dynamics и др.);

Помимо этого, одним из направлений компании «ЭлектроПласт» является направление «Источники питания». Мы предлагаем Вам помощь Конструкторского отдела:

- Подбор оптимального решения, техническое обоснование при выборе компонента;
- Подбор аналогов;
- Консультации по применению компонента;
- Поставка образцов и прототипов;
- Техническая поддержка проекта;
- Защита от снятия компонента с производства.



#### Как с нами связаться

**Телефон:** 8 (812) 309 58 32 (многоканальный)

**Факс:** 8 (812) 320-02-42

**Электронная почта:** [org@eplast1.ru](mailto:org@eplast1.ru)

**Адрес:** 198099, г. Санкт-Петербург, ул. Калинина, дом 2, корпус 4, литера А.