

Multilayer Ferrite Chip Bead (High Current)

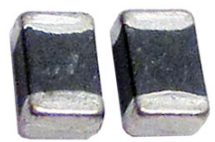

1.00 x 0.50 x 0.50mm

ACML-0402HC



RoHS/RoHS II Compliant

FEATURES:

- Multilayer monolithic structure yields high reliability
- Unique terminal electrode design ensures high rated current
- High impedance over a wide frequency range

APPLICATIONS:

- Noise suppression for computers and peripheral devices, DVD cameras, LCD TVs, communication equipments, OA equipments, etc.
- Reduces noise in ultra high speed circuits as well

STANDARD SPECIFICATIONS:

Operating Temperature: -55°C ~ +125°C

Storage Temperature: -55°C to +125°C

Part Number ACML-0402HC- Impedance Code	Impedance	Frequency	DC resistance	Rated Current
Units	$\Omega \pm 25\%$	MHz	Ω max	mA max
Symbol	Z	F	R _{DC}	I _R
ACML-0402HC-050	5	100	0.05	2000
ACML-0402HC-110	11	100	0.05	2000
ACML-0402HC-310	31	100	0.06	1500
ACML-0402HC-600	60	100	0.08	1500
ACML-0402HC-700	70	100	0.10	1300
ACML-0402HC-121	120	100	0.10	1200
ACML-0402HC-221	220	100	0.25	1000
ACML-0402HC-301	300	100	0.30	1000

Test Conditions and Equipments

I_R: Rated current applied when the chip surface temperature rise just 40°C against chip surface temperature.
Electric power supplier, Electric current meter, Thermometer.

Z: Impedance Analyzer HP4291 or equivalent, 50mV.

DCR: LCR Meter HP4263A or equivalent

OPTIONS AND PART IDENTIFICATION:

ACML-0402HC- -

Impedance Code
Please refer to the
Electrical Specification
table

Packaging
T: Tape and Reel
(10kpcs / reel)

Multilayer Ferrite Chip Bead (High Current)



1.00 x 0.50 x 0.50mm

ACML-0402HC

Pb RoHS/RoHS II Compliant

FREQUENCY RESPONSE

ACML-0402HC-110

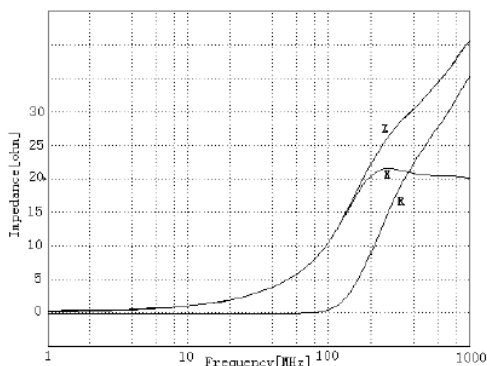

ACML-0402HC-600

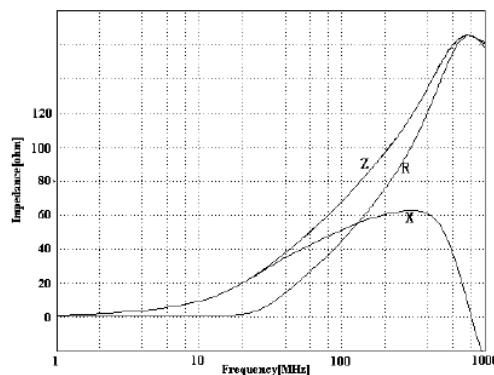

ACML-0402HC-121

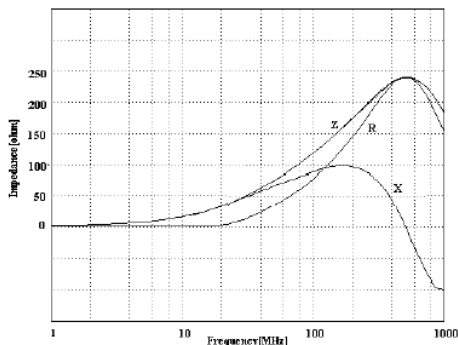

ACML-0402HC-301

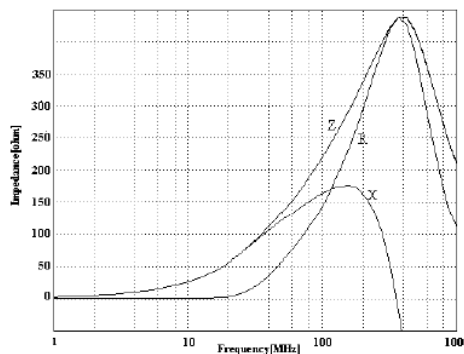

OUTLINE DIMENSIONS:

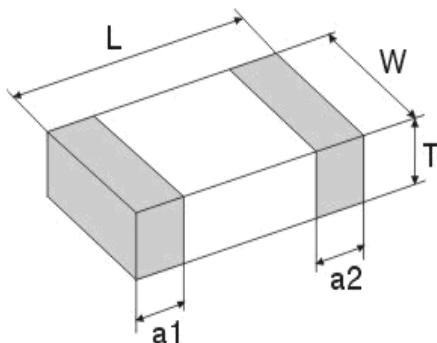

L	W	T	a1, a2
1.00±0.15	0.50±0.15	0.50±0.15	0.25±0.10

Materials

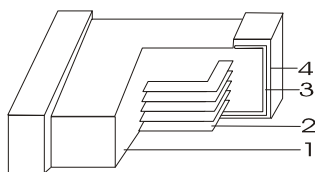

	Part Name	Material
1	Base Material	Ferrite
2	Internal Conductor	Ag
3	Terminal Electrode	Ag
4	Terminal Electrode	Ni-Sn

Dimension: mm

ABRACON IS
ISO 9001:2008
CERTIFIED



Visit www.abracon.com for Terms & Conditions of Sale **Revised: 11.11.13**
30332 Esperanza, Rancho Santa Margarita, California 92688
tel 949-546-8000 | fax 949-546-8001 | www.abracon.com

Multilayer Ferrite Chip Bead (High Current)

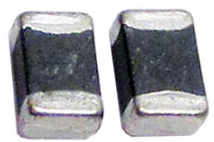

1.00 x 0.50 x 0.50mm

ACML-0402HC



RoHS/RoHS II Compliant

REFLOW PROFILE

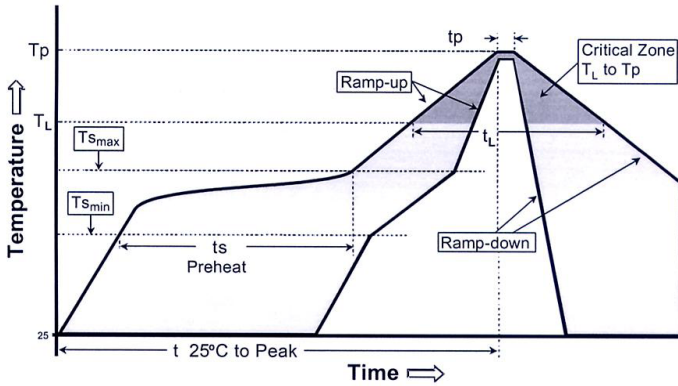

Profile Feature	Lead-Free Assembly
Time maintained above: - Temperature (TL) - Time (tL)	217 °C 60-150 seconds
Peak/Classification Temperature (Tp) Peak/Classification Time (tp)	260 °C 3-4 seconds
Time within 5 °C of actual Peak Temperature (tp)	20-40 seconds
Ramp-Down Rate	6°C/second max.
Time 25 °C to Peak Temperature	8 minutes max.

TAPE & REEL:

T= tape and reel (10,000 pcs/reel)

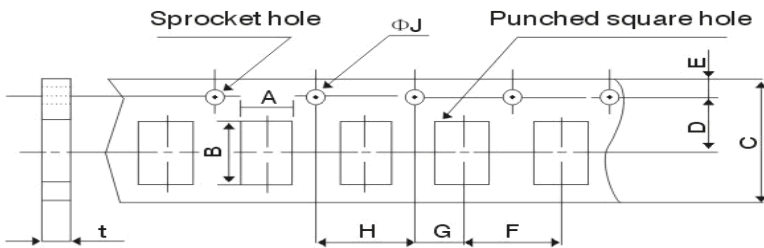

T	0.5±0.15
A	0.65±0.15
B	1.15±0.15
C	8.0±0.3
D	3.5±0.05
E	1.75±0.1
F	2.0±0.05
G	2.0±0.05
H	4.0±0.1
ΦJ	1.5+0.1/-0
t(max)	0.8±0.05

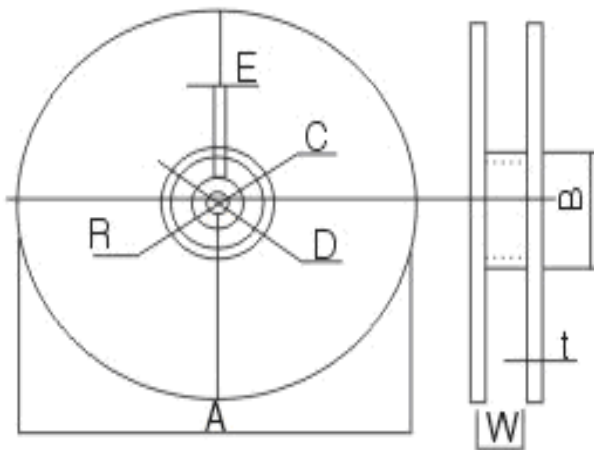

A	178±2
B	60±2
C	13.0±0.5
D	21.0±0.8
E	2.0±0.5
W	10.0±1.15
t	1.2±0.2
R	1.0±0.25

Dimension: mm

ATTENTION: Abracon Corporation's products are COTS – Commercial-Off-The-Shelf products; suitable for Commercial, Industrial and, where designated, Automotive Applications. Abracon's products are not specifically designed for Military, Aviation, Aerospace, Life-dependant Medical applications or any application requiring high reliability where component failure could result in loss of life and/or property. For applications requiring high reliability and/or presenting an extreme operating environment, written consent and authorization from Abracon Corporation is required. Please contact Abracon Corporation for more information.

ABRACON IS
ISO 9001:2008
CERTIFIED



Visit www.abracon.com for Terms & Conditions of Sale **Revised: 11.11.13**
30332 Esperanza, Rancho Santa Margarita, California 92688
tel 949-546-8000 | fax 949-546-8001 | www.abracon.com



Компания «ЭлектроПласт» предлагает заключение долгосрочных отношений при поставках импортных электронных компонентов на взаимовыгодных условиях!

Наши преимущества:

- Оперативные поставки широкого спектра электронных компонентов отечественного и импортного производства напрямую от производителей и с крупнейших мировых складов;
- Поставка более 17-ти миллионов наименований электронных компонентов;
- Поставка сложных, дефицитных, либо снятых с производства позиций;
- Оперативные сроки поставки под заказ (от 5 рабочих дней);
- Экспресс доставка в любую точку России;
- Техническая поддержка проекта, помощь в подборе аналогов, поставка прототипов;
- Система менеджмента качества сертифицирована по Международному стандарту ISO 9001;
- Лицензия ФСБ на осуществление работ с использованием сведений, составляющих государственную тайну;
- Поставка специализированных компонентов (Xilinx, Altera, Analog Devices, Intersil, Interpoint, Microsemi, Aeroflex, Peregrine, Syfer, Eurofarad, Texas Instrument, Miteq, Cobham, E2V, MA-COM, Hittite, Mini-Circuits, General Dynamics и др.);

Помимо этого, одним из направлений компании «ЭлектроПласт» является направление «Источники питания». Мы предлагаем Вам помощь Конструкторского отдела:

- Подбор оптимального решения, техническое обоснование при выборе компонента;
- Подбор аналогов;
- Консультации по применению компонента;
- Поставка образцов и прототипов;
- Техническая поддержка проекта;
- Защита от снятия компонента с производства.



Как с нами связаться

Телефон: 8 (812) 309 58 32 (многоканальный)

Факс: 8 (812) 320-02-42

Электронная почта: org@eplast1.ru

Адрес: 198099, г. Санкт-Петербург, ул. Калинина, дом 2, корпус 4, литера А.