

TPC-1551T(B)

15" XGA TFT LED LCD Thin-Client Terminal with Intel® Atom™ Processor

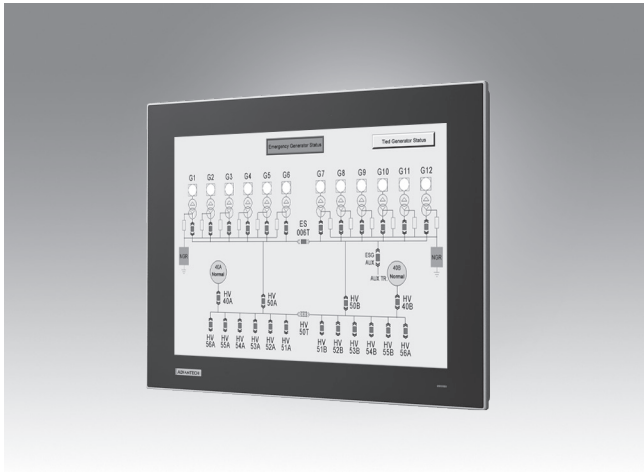

Features

- Industrial-grade 15" XGA TFT LCD with 70K lifetime and LED backlight
- Intel® Atom™ E3845 1.91 GHz quad-core processor with 4 GB DDR3L SDRAM
- True-flat touchscreen with 5-wire resistive touch control and IP66-rated front panel
- Wide operating temperature range (-20 ~ 60 °C/-4 ~ 140 °F)
- Front-facing LED indicators to show operating status
- Advantech iDoor technology and SSD/HDD bay
- Compact, fanless system with aluminum alloy front bezel and chassis grounding protection
- Supports VESA mount (100 x 100 mm)
- Supports Advantech's SNMP Subagent software
- Supports Advantech's WISE-PaaS/RMM remote management software

Introduction

The TPC-1551T(B) thin-client terminal is the next-generation model of Advantech's TPC-1551T(A) industrial panel PC. Equipped with a 15" XGA TFT LED LCD, low-power Intel® Atom™ E3845, 1.91GHz, quad-core processor, and 4 GB of DDR3L SDRAM, TPC-1551T(B) delivers high-performance computing in a compact, fanless system. For enhanced durability to satisfy diverse industrial automation applications, TPC-1551T(B) supports a wide operating temperature range (-20 ~ 60 °C/-4 ~ 140 °F) and features a true-flat 5-wire resistive touchscreen with IP66-rated front panel, die-cast aluminum alloy front bezel, and 100 x 100 VESA mount kit. Moreover, with the provision of a full-size mini PCIe slot that supports mSATA signals and Advantech's iDoor technology, TPC-1551T(B) can be easily expanded to provide additional I/O ports, isolated digital I/O, fieldbus protocols, MRAM, and 3G/GPS/GPRS/Wi-Fi communication capabilities.

Specifications

General

- **BIOS** AMI UEFI
- **Certification** BSMI, CCC, CE, FCC Class A, UL
- **Cooling System** Fanless design
- **Dimensions (W x H x D)** 383.2 x 307.3 x 55.9 mm (15.09 x 12.10 x 2.2 in)
- **Enclosure** Front bezel: Die-cast aluminum alloy
Back housing: SECC
- **Mount Options** Desktop/wall/panel
- **OS Support** Microsoft® WES7 (32/64-bit), Windows 7 (32/64-bit), Windows 10 Enterprise LTSB
- **Power Consumption** 50.8W (typical)
- **Power Input** 24 V_{DC} +/- 20%
- **Watchdog Timer** 1 ~ 255 sec (system)
- **Weight (Net)** 4.4 kg (9.7 lb)

System Hardware

- **CPU** Intel® Atom™ E3845, 1.91 GHz, quad core
- **Memory** 1 x SODIMM with 4 GB DDR3L SDRAM (up to 8 GB)
- **LAN** 2 x Intel® I210; 10/100/1000 BASE-T
- **Expansion Slots** 1 x Full-size mini PCIe with mSATA support
- **Storage** 1 x 2.5" SATA SSD
- **I/O** 1 x RS-232
1 x RS-232/422/485
1 x USB 3.0
3 x USB 2.0
1 x iDoor slot

LCD

- **Display Type** XGA TFT LED LCD
- **Display Size** 15"
- **Max. Resolution** 1024 x 768
- **Max. Colors** 16.2M
- **Luminance** 300 cd/m²
- **Viewing Angle (H/V°)** 176/176
- **Backlight Life** 70,000 hr
- **Contrast Ratio** 2000:1

Touchscreen

- **Lifespan** 36 million touches at a single point
- **Light Transmission** Above 75%
- **Resolution** Linearity
- **Type** 5-wire analog resistive

Environment

- **Humidity** 10 ~ 95% RH @ 40 °C, non-condensing
- **Ingress Protection** IP66-rated front panel
- **Operating Temperature** -20 ~ 60 °C (-4 ~ 140 °F)
- **Storage Temperature** -30 ~ 70 °C (-22 ~ 158 °F)
- **Vibration Protection** With SSD: 1 Grms (5 ~ 500 Hz) (operating, random vibration)

Rear View

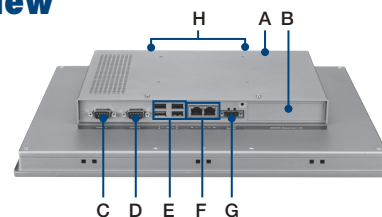

- A. HDD/SSD bay
- B. iDoor slot
- C. RS-232
- D. RS-232/422/485
- E. USB 2.0 and 3.0
- F. LAN (10/100/1000)
- G. Power input
- H. Antenna port

Dimensions

Unit: mm

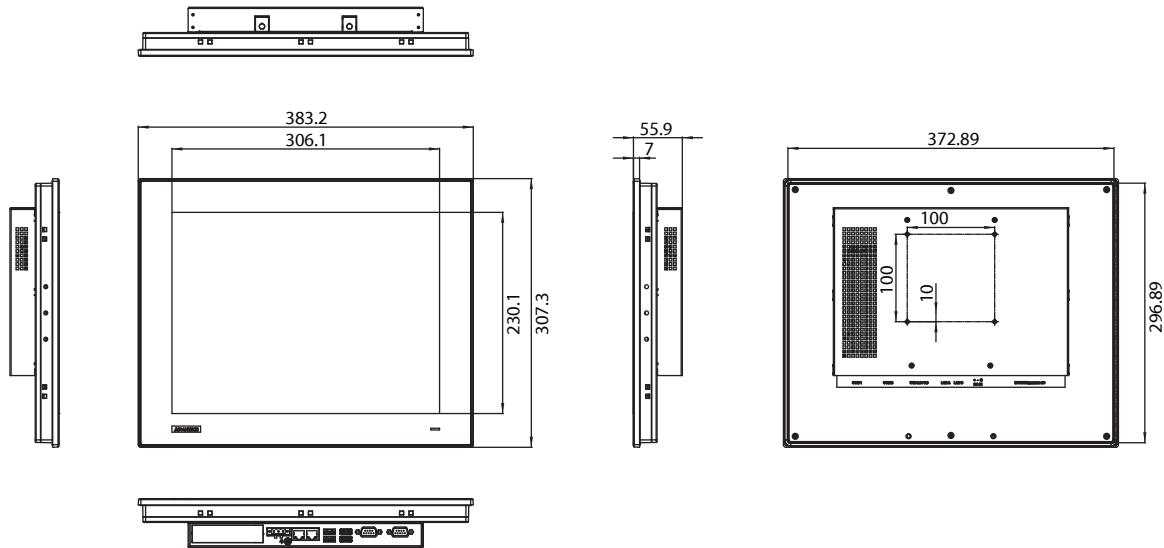

Panel Cutout Dimensions: 374.5 x 298.5 mm (14.74 x 11.75 in)

Ordering Information

- **TPC-1551T-E3BE** 15" XGA panel PC with Intel® Atom™ E3845, 1.91 GHz quad-core CPU, 4 GB DDR3L SDRAM, and true-flat touchscreen

Note: Can be equipped with an Intel® Atom™ J1900 CPU upon request

- **PCM-262R2EC-MAE** Hilscher netX100 fieldbus mPCIe with EtherCAT, 2 x RJ45, Master
- **PCM-27J3AU-AE** 3-Port audio stereo with mPCIe and 3.5-mm jack
- **PCM-29R1TX-AE** 1-Port iLink(TX) long-distance display transmitter with RJ45

Optional Accessories

- **PWR-247-CE** 60 W, 24 VDC /2.5A power supply
- **1702002600** Power cable (US) 1.8 M
- **1702002605** Power cable (EU) 1.8 M
- **1702031801** Power cable (UK) 1.8 M
- **1700000596-11** Power cable (China/Australia) 1.8 M

Embedded OS

- **20703WE7PS0027** TPC-xx51T(B) WS7P x86 MUI Image V4.19
- **20703WE7PS0028** TPC-xx51T(B) WS7P x64 MUI Image V4.19

iDoor Modules

- **PCM-26D2CA-AE** SJA1000 CANbus module with CANopen and 2 x DB9
- **PCM-26D1DB-MAE** Hilscher netX100 fieldbus module with PROFIBUS and 1 x DB9
- **PCM-27D24DI-AE** Digital I/O module with 16 DI/8 DO, isolation protection, and 1 x DB37
- **PCM-24D2R4-BE** OXPcie-952 UART with isolated RS-422/485 and 2 x DB9
- **PCM-24D2R2-BE** OXPcie-952 UART with isolated RS-232 and 2 x DB9
- **PCM-24R2GL-AE** 2-Port GigaLAN Intel® i350 PCIe mini card
- **PCM-24R1TP-AE** Intel® 82574L, GbE, IEEE 1588 PTP, 1 x RJ45

Application Software

WebAccess/SCADA	Advantech WebAccess/SCADA is a 100% browser-based IIoT software platform aimed at supervisory control and data acquisition (SCADA) operations. WebAccess/SCADA provides open interfaces that allow our customers and partners to develop unique IoT applications for different vertical markets. In addition to supporting traditional SCADA functions, the platform features an HTML5-based user interface and intelligent dashboard to facilitate cross-platform, cross-browser data analysis. Moreover, WebAccess/SCADA not only offers built-in widgets, but is also equipped with an innovative Widget Builder that enables customers to build their own widgets.
WebAccess/HMI	Advantech WebAccess/HMI is human-machine interface (HMI) software based on Microsoft's Windows operating system. This software features excellent communication and monitoring capabilities, supports more than 350 PLC communication protocols, and offers a wide choice of screen design objects to satisfy diverse automation applications and HMI monitoring requirements.



Компания «ЭлектроПласт» предлагает заключение долгосрочных отношений при поставках импортных электронных компонентов на взаимовыгодных условиях!

Наши преимущества:

- Оперативные поставки широкого спектра электронных компонентов отечественного и импортного производства напрямую от производителей и с крупнейших мировых складов;
- Поставка более 17-ти миллионов наименований электронных компонентов;
- Поставка сложных, дефицитных, либо снятых с производства позиций;
- Оперативные сроки поставки под заказ (от 5 рабочих дней);
- Экспресс доставка в любую точку России;
- Техническая поддержка проекта, помощь в подборе аналогов, поставка прототипов;
- Система менеджмента качества сертифицирована по Международному стандарту ISO 9001;
- Лицензия ФСБ на осуществление работ с использованием сведений, составляющих государственную тайну;
- Поставка специализированных компонентов (Xilinx, Altera, Analog Devices, Intersil, Interpoint, Microsemi, Aeroflex, Peregrine, Syfer, Eurofarad, Texas Instrument, Miteq, Cobham, E2V, MA-COM, Hittite, Mini-Circuits, General Dynamics и др.);

Помимо этого, одним из направлений компании «ЭлектроПласт» является направление «Источники питания». Мы предлагаем Вам помощь Конструкторского отдела:

- Подбор оптимального решения, техническое обоснование при выборе компонента;
- Подбор аналогов;
- Консультации по применению компонента;
- Поставка образцов и прототипов;
- Техническая поддержка проекта;
- Защита от снятия компонента с производства.



Как с нами связаться

Телефон: 8 (812) 309 58 32 (многоканальный)

Факс: 8 (812) 320-02-42

Электронная почта: org@eplast1.ru

Адрес: 198099, г. Санкт-Петербург, ул. Калинина, дом 2, корпус 4, литера А.