

256K x 16 LOW VOLTAGE, ULTRA LOW POWER CMOS STATIC SRAM

JUNE 2011

FEATURES

- High-speed access time: 55ns, 70ns
- CMOS low power operation
36 mW (typical) operating
9 μ W (typical) CMOS standby
- TTL compatible interface levels
- Single power supply
1.65V--2.2V V_{DD} (IS62WV25616ALL)
2.5V--3.6V V_{DD} (IS62WV25616BLL)
- Fully static operation: no clock or refresh required
- Three state outputs
- Data control for upper and lower bytes
- Industrial temperature available
- Lead-free available

DESCRIPTION

The *ISSI* IS62WV25616ALL/IS62WV25616BLL are high-speed, low power, 4M bit SRAMs organized as 256K words by 16 bits. It is fabricated using *ISSI*'s high-performance CMOS technology. This highly reliable process coupled with innovative circuit design techniques, yields high-performance and low power consumption devices.

When $\overline{CS1}$ is HIGH (deselected) or when $\overline{CS1}$ is LOW and both \overline{LB} and \overline{UB} are HIGH, the device assumes a standby mode at which the power dissipation can be reduced down with CMOS input levels.

Easy memory expansion is provided by using Chip Enable and Output Enable inputs. The active LOW Write Enable (\overline{WE}) controls both writing and reading of the memory. A data byte allows Upper Byte (\overline{UB}) and Lower Byte (\overline{LB}) access.

The IS62WV25616ALL/IS62WV25616BLL are packaged in the JEDEC standard 44-Pin TSOP (TYPE II) and 48-pin mini BGA (6mmx8mm).

FUNCTIONAL BLOCK DIAGRAM

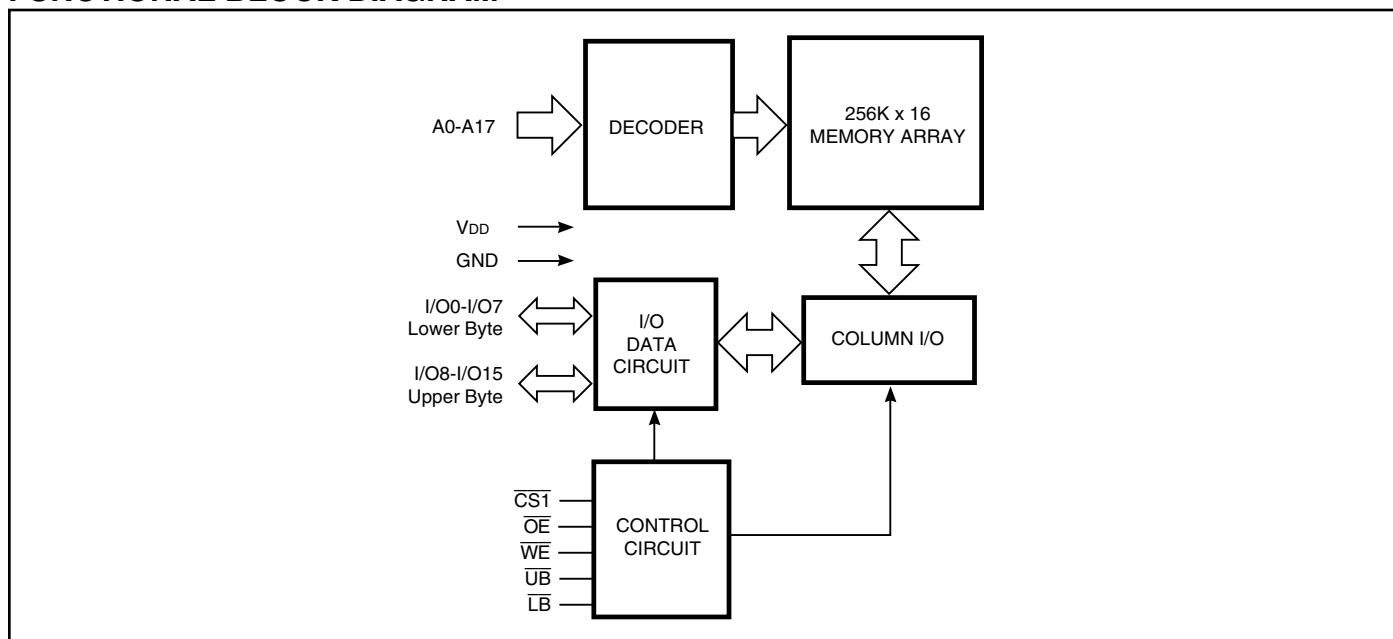

Copyright © 2011 Integrated Silicon Solution, Inc. All rights reserved. ISSI reserves the right to make changes to this specification and its products at any time without notice. ISSI assumes no liability arising out of the application or use of any information, products or services described herein. Customers are advised to obtain the latest version of this device specification before relying on any published information and before placing orders for products.

Integrated Silicon Solution, Inc. does not recommend the use of any of its products in life support applications where the failure or malfunction of the product can reasonably be expected to cause failure of the life support system or to significantly affect its safety or effectiveness. Products are not authorized for use in such applications unless Integrated Silicon Solution, Inc. receives written assurance to its satisfaction, that:

- a.) the risk of injury or damage has been minimized;
- b.) the user assume all such risks; and
- c.) potential liability of Integrated Silicon Solution, Inc is adequately protected under the circumstances

PIN CONFIGURATIONS

**48- ball mini BGA (6mm x 8mm)
(Package Code B)**

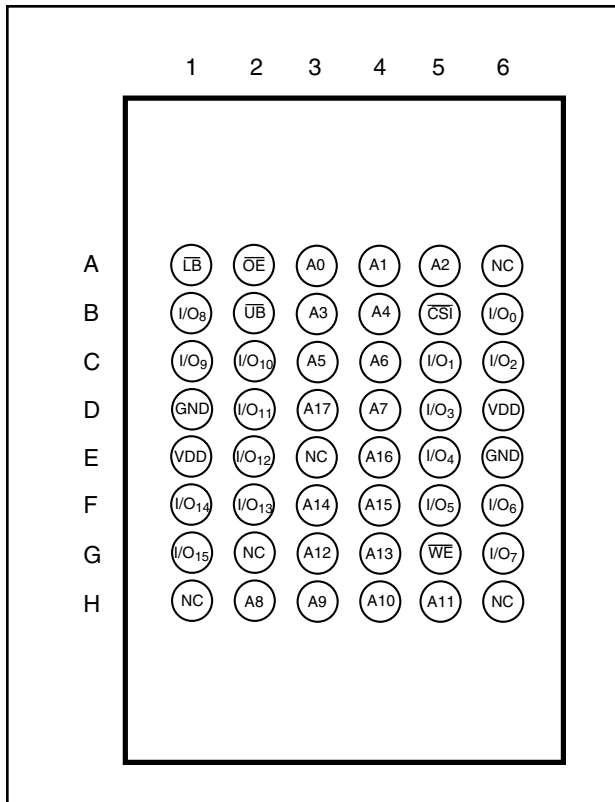

**44-Pin mini TSOP (Type II)
(Package Code T)**

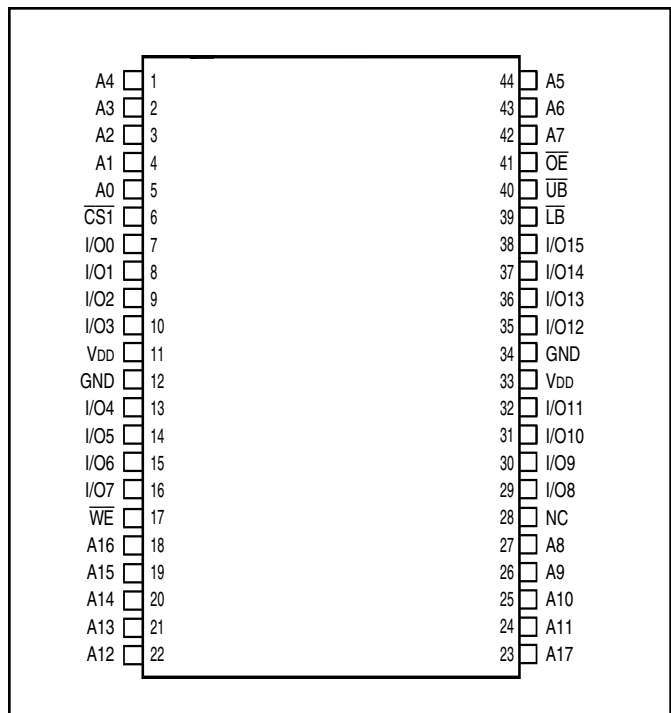

PIN DESCRIPTIONS

A0-A17	Address Inputs
I/O0-I/O15	Data Inputs/Outputs
CS1	Chip Enable Input
OE	Output Enable Input
WE	Write Enable Input
LB	Lower-byte Control (I/O0-I/O7)
UB	Upper-byte Control (I/O8-I/O15)
NC	No Connection
VDD	Power
GND	Ground

TRUTH TABLE

Mode	\overline{WE}	$\overline{CS1}$	\overline{OE}	\overline{LB}	\overline{UB}	I/O PIN		V _{DD} Current
						I/O0-I/O7	I/O8-I/O15	
Not Selected	X	H	X	X	X	High-Z	High-Z	I _{SB1} , I _{SB2}
	X	X	X	H	H	High-Z	High-Z	I _{SB1} , I _{SB2}
Output Disabled	H	L	H	L	X	High-Z	High-Z	I _{CC}
	H	L	H	X	L	High-Z	High-Z	I _{CC}
Read	H	L	L	L	H	DOUT	High-Z	I _{CC}
	H	L	L	H	L	High-Z	DOUT	
	H	L	L	L	L	DOUT	DOUT	
Write	L	L	X	L	H	DIN	High-Z	I _{CC}
	L	L	X	H	L	High-Z	DIN	
	L	L	X	L	L	DIN	DIN	

ABSOLUTE MAXIMUM RATINGS⁽¹⁾

Symbol	Parameter	Value	Unit
V _{TERM}	Terminal Voltage with Respect to GND	-0.2 to V _{DD} +0.3	V
V _{DD}	V _{DD} Related to GND	-0.2 to V _{DD} +0.3	V
T _{STG}	Storage Temperature	-65 to +150	°C
P _T	Power Dissipation	1.0	W

Note:

1. Stress greater than those listed under ABSOLUTE MAXIMUM RATINGS may cause permanent damage to the device. This is a stress rating only and functional operation of the device at these or any other conditions above those indicated in the operational sections of this specification is not implied. Exposure to absolute maximum rating conditions for extended periods may affect reliability.

OPERATING RANGE (V_{DD})

Range	Ambient Temperature	IS62WV25616ALL	IS62WV25616BLL
Commercial	0°C to +70°C	1.65V - 2.2V	2.5V-3.6V
Industrial	-40°C to +85°C	1.65V - 2.2V	2.5V-3.6V

DC ELECTRICAL CHARACTERISTICS (Over Operating Range)

Symbol	Parameter	Test Conditions	V _{DD}	Min.	Max.	Unit
V _{OH}	Output HIGH Voltage	I _{OH} = -0.1 mA	1.65-2.2V	1.4	—	V
		I _{OH} = -1 mA	2.5-3.6V	2.2	—	V
V _{OL}	Output LOW Voltage	I _{OL} = 0.1 mA	1.65-2.2V	—	0.2	V
		I _{OL} = 2.1 mA	2.5-3.6V	—	0.4	V
V _{IH}	Input HIGH Voltage		1.65-2.2V	1.4	V _{DD} + 0.2	V
			2.5-3.6V	2.2	V _{DD} + 0.3	V
V _{IL} ⁽¹⁾	Input LOW Voltage		1.65-2.2V	-0.2	0.4	V
			2.5-3.6V	-0.2	0.8	V
I _{LI}	Input Leakage	GND ≤ V _{IN} ≤ V _{DD}		-1	1	μA
I _{LO}	Output Leakage	GND ≤ V _{OUT} ≤ V _{DD} , Outputs Disabled		-1	1	μA

Notes: 1. V_{IL} (min.) = -1.0V for pulse width less than 10 ns.

IS62WV25616ALL, IS62WV25616BLL

IS62WV25616ALL, POWER SUPPLY CHARACTERISTICS⁽¹⁾ (Over Operating Range)

Symbol	Parameter	Test Conditions		Max.		Unit
				70		
I _{CC}	V _{DD} Dynamic Operating Supply Current	V _{DD} = Max.,	Com.	25		mA
		I _{OUT} = 0 mA, f = f _{MAX}	Ind.	30		
I _{CC1}	Operating Supply Current	V _{DD} = Max., $\overline{CS1} = 0.2V$	Com.	10		mA
		$\overline{WE} = V_{DD} - 0.2V$ f = 1MHz	Ind.	10		
I _{SB1}	TTL Standby Current (TTL Inputs)	V _{DD} = Max., V _{IN} = V _{IH} or V _{IL} $\overline{CS1} = V_{IH}$, f = 1 MHz	Com. Ind.	0.35 0.35		mA
	ULB Control	V _{DD} = Max., V _{IN} = V _{IH} or V _{IL} $\overline{CS1} = V_{IL}$, f = 0, $\overline{UB} = V_{IH}$, $\overline{LB} = V_{IH}$				
I _{SB2}	CMOS Standby Current (CMOS Inputs)	V _{DD} = Max., $\overline{CS1} \geq V_{DD} - 0.2V$, V _{IN} ≥ V _{DD} - 0.2V, or V _{IN} ≤ 0.2V, f = 0	Com. Ind.	15 15		μA
	ULB Control	V _{DD} = Max., $\overline{CS1} = V_{IL}$, V _{IN} ≤ 0.2V, f = 0; $\overline{UB} / \overline{LB} = V_{DD} - 0.2V$				

IS62WV25616BLL, POWER SUPPLY CHARACTERISTICS⁽¹⁾ (Over Operating Range)

Symbol	Parameter	Test Conditions		Max.		Unit
				55	70	
I _{CC}	V _{DD} Dynamic Operating Supply Current	V _{DD} = Max.,	Com.	40	35	mA
		I _{OUT} = 0 mA, f = f _{MAX}	Ind.	45	40	
I _{CC1}	Operating Supply Current	V _{DD} = Max., $\overline{CS1} = 0.2V$	Com.	15	15	mA
		$\overline{WE} = V_{DD} - 0.2V$ f = 1MHz	Ind.	15	15	
I _{SB1}	TTL Standby Current (TTL Inputs)	V _{DD} = Max., V _{IN} = V _{IH} or V _{IL} $\overline{CS1} = V_{IH}$, f = 1 MHz	Com. Ind.	0.35 0.35	0.35 0.35	mA
	ULB Control	V _{DD} = Max., V _{IN} = V _{IH} or V _{IL} $\overline{CS1} = V_{IL}$, f = 0, $\overline{UB} = V_{IH}$, $\overline{LB} = V_{IH}$				
I _{SB2}	CMOS Standby Current (CMOS Inputs)	V _{DD} = Max., $\overline{CS1} \geq V_{DD} - 0.2V$, V _{IN} ≥ V _{DD} - 0.2V, or V _{IN} ≤ 0.2V, f = 0	Com. Ind. typ. ⁽¹⁾	15 15 3	15 15	μA
	ULB Control	V _{DD} = Max., $\overline{CS1} = V_{IL}$, V _{IN} ≤ 0.2V, f = 0; $\overline{UB} / \overline{LB} = V_{DD} - 0.2V$				

Note:

1. Typical values are measured at V_{DD} = 3.0V, T_A = 25°C. Not 100% tested.

CAPACITANCE⁽¹⁾

Symbol	Parameter	Conditions	Max.	Unit
C _{IN}	Input Capacitance	V _{IN} = 0V	8	pF
C _{OUT}	Input/Output Capacitance	V _{OUT} = 0V	10	pF

Note:

1. Tested initially and after any design or process changes that may affect these parameters.

AC TEST CONDITIONS

Parameter	IS62WV25616ALL (Unit)	IS62WV25616BLL (Unit)
Input Pulse Level	0.4V to V _{DD} -0.2V	0.4V to V _{DD} -0.3V
Input Rise and Fall Times	5 ns	5ns
Input and Output Timing and Reference Level	V _{REF}	V _{REF}
Output Load	See Figures 1 and 2	See Figures 1 and 2

	IS62WV25616ALL 1.65V-2.2V	IS62WV25616BLL 2.5V - 3.6V
R1(Ω)	3070	3070
R2(Ω)	3150	3150
V _{REF}	0.9V	1.5V
V _{TM}	1.8V	2.8V

AC TEST LOADS

Figure 1

Figure 2

READ CYCLE SWITCHING CHARACTERISTICS⁽¹⁾ (Over Operating Range)

Symbol	Parameter	55 ns		70 ns		Unit
		Min.	Max.	Min.	Max.	
t _{RC}	Read Cycle Time	55	—	70	—	ns
t _{AA}	Address Access Time	—	55	—	70	ns
t _{OHA}	Output Hold Time	10	—	10	—	ns
t _{ACS1}	$\overline{CS1}$ Access Time	—	55	—	70	ns
t _{DOE}	\overline{OE} Access Time	—	25	—	35	ns
t _{HZOE⁽²⁾}	\overline{OE} to High-Z Output	—	20	—	25	ns
t _{LZOE⁽²⁾}	\overline{OE} to Low-Z Output	5	—	5	—	ns
t _{HZCS1}	$\overline{CS1}$ to High-Z Output	0	20	0	25	ns
t _{LZCS1}	$\overline{CS1}$ to Low-Z Output	10	—	10	—	ns
t _{BA}	\overline{LB} , \overline{UB} Access Time	—	55	—	70	ns
t _{HZB}	\overline{LB} , \overline{UB} to High-Z Output	0	20	0	25	ns
t _{LZB}	\overline{LB} , \overline{UB} to Low-Z Output	0	—	0	—	ns

Notes:

1. Test conditions assume signal transition times of 5 ns or less, timing reference levels of 0.9V/1.5V, input pulse levels of 0.4 to V_{DD}-0.2V/V_{DD}-0.3V and output loading specified in Figure 1.
2. Tested with the load in Figure 2. Transition is measured ±500 mV from steady-state voltage. Not 100% tested.

AC WAVEFORMS
READ CYCLE NO. 1^(1,2) (Address Controlled) ($\overline{CS1} = \overline{OE} = V_{IL}$, $\overline{WE} = V_{IH}$, \overline{UB} or $\overline{LB} = V_{IL}$)

READ CYCLE NO. 2^(1,3) ($\overline{CS1}$, \overline{OE} , AND $\overline{UB}/\overline{LB}$ Controlled)

Notes:

1. \overline{WE} is HIGH for a Read Cycle.
2. The device is continuously selected. \overline{OE} , $\overline{CS1}$, \overline{UB} , or $\overline{LB} = V_{IL}$. $\overline{WE} = V_{IH}$.
3. Address is valid prior to or coincident with $\overline{CS1}$ LOW transition.

WRITE CYCLE SWITCHING CHARACTERISTICS^(1,2) (Over Operating Range)

Symbol	Parameter	55 ns		70 ns		Unit
		Min.	Max.	Min.	Max.	
t _{wc}	Write Cycle Time	55	—	70	—	ns
t _{sCS1}	$\overline{\text{CS1}}$ to Write End	45	—	60	—	ns
t _{aw}	Address Setup Time to Write End	45	—	60	—	ns
t _{ha}	Address Hold from Write End	0	—	0	—	ns
t _{sa}	Address Setup Time	0	—	0	—	ns
t _{pWB}	$\overline{\text{LB}}$, $\overline{\text{UB}}$ Valid to End of Write	45	—	60	—	ns
t _{pWE}	$\overline{\text{WE}}$ Pulse Width	40	—	50	—	ns
t _{sd}	Data Setup to Write End	25	—	30	—	ns
t _{hd}	Data Hold from Write End	0	—	0	—	ns
t _{hzWE⁽³⁾}	$\overline{\text{WE}}$ LOW to High-Z Output	—	20	—	20	ns
t _{lzWE⁽³⁾}	$\overline{\text{WE}}$ HIGH to Low-Z Output	5	—	5	—	ns

Notes:

1. Test conditions assume signal transition times of 5 ns or less, timing reference levels of 0.9V/1.5V, input pulse levels of 0.4V to V_{DD}-0.2V/V_{DD}-0.3V and output loading specified in Figure 1.
2. The internal write time is defined by the overlap of $\overline{\text{CS1}}$ LOW and $\overline{\text{UB}}$ or $\overline{\text{LB}}$, and $\overline{\text{WE}}$ LOW. All signals must be in valid states to initiate a Write, but any one can go inactive to terminate the Write. The Data Input Setup and Hold timing are referenced to the rising or falling edge of the signal that terminates the write.
3. Tested with the load in Figure 2. Transition is measured ± 500 mV from steady-state voltage. Not 100% tested.

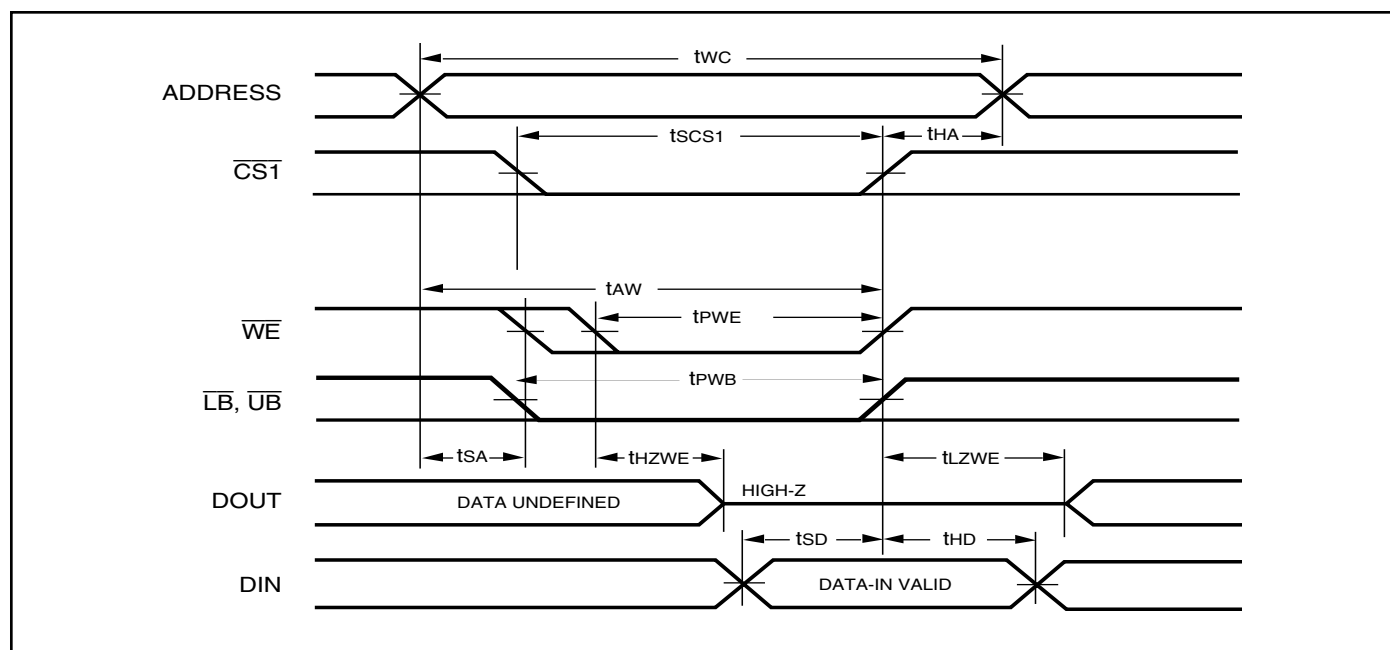
AC WAVEFORMS
WRITE CYCLE NO. 1^(1,2) ($\overline{CS1}$ Controlled, \overline{OE} = HIGH or LOW)

Notes:

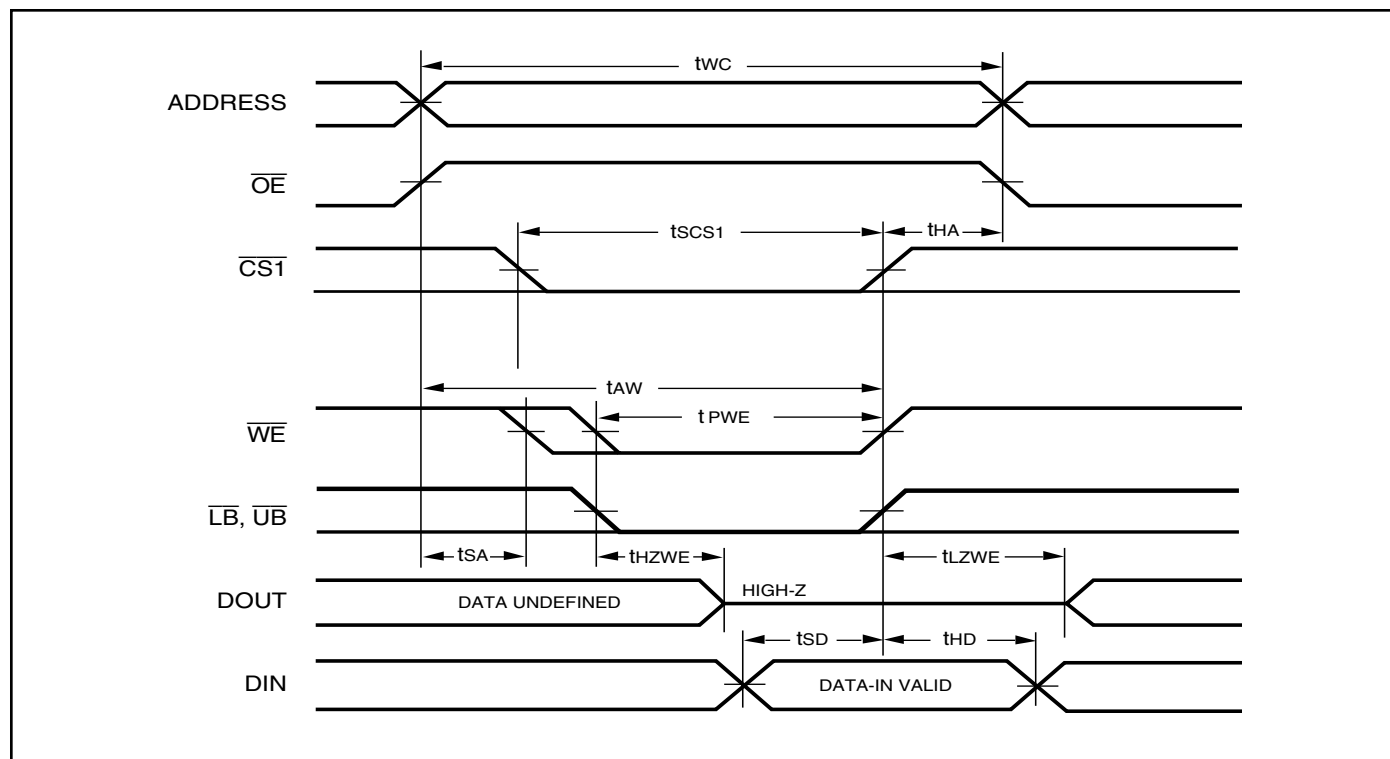
1. WRITE is an internally generated signal asserted during an overlap of the LOW states on the $\overline{CS1}$ and \overline{WE} inputs and at least one of the \overline{LB} and \overline{UB} inputs being in the LOW state.
2. $WRITE = (\overline{CS1}) [(\overline{LB}) = (\overline{UB})] (\overline{WE})$.

WRITE CYCLE NO. 2 (\overline{WE} Controlled: \overline{OE} is HIGH During Write Cycle)

WRITE CYCLE NO. 3 (\overline{OE} Controlled: \overline{OE} is LOW During Write Cycle)



WRITE CYCLE NO. 4 ($\overline{UB}/\overline{LB}$ Controlled)



UB_CSWR4.eps

DATA RETENTION SWITCHING CHARACTERISTICS

Symbol	Parameter	Test Condition	Min.	Max.	Unit
V _{DR}	V _{DD} for Data Retention	See Data Retention Waveform	1.2	3.6	V
I _{DR}	Data Retention Current	V _{DD} = 1.2V, $\overline{CS1} \geq V_{DD} - 0.2V$	—	15	μA
t _{SDR}	Data Retention Setup Time	See Data Retention Waveform	0	—	ns
t _{RDR}	Recovery Time	See Data Retention Waveform	t _{RC}	—	ns

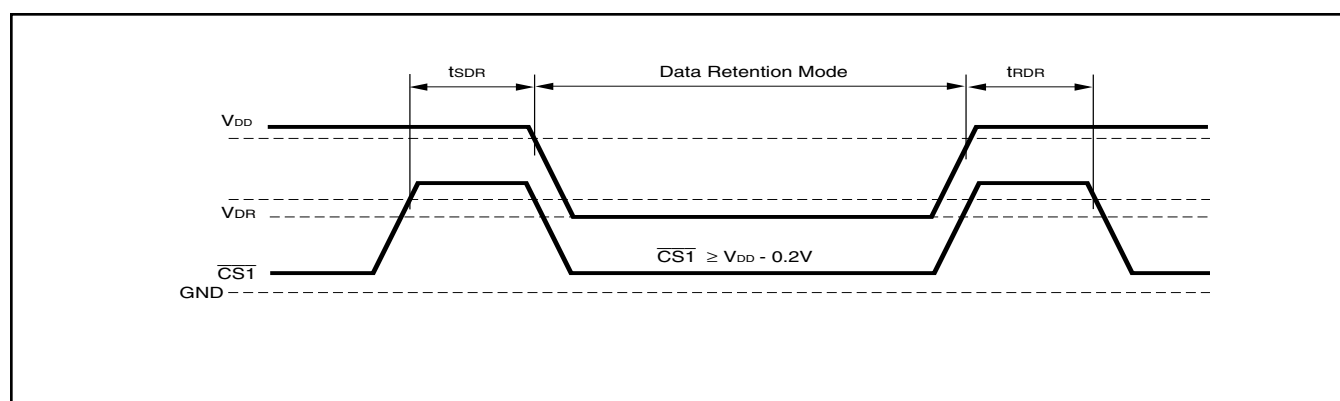
DATA RETENTION WAVEFORM ($\overline{CS1}$ Controlled)

IS62WV25616ALL, IS62WV25616BLL

ORDERING INFORMATION

IS62WV25616ALL (1.65V-2.2V)

Commercial Range: 0°C to +70°C

Speed (ns)	Order Part No.	Package
70	IS62WV25616ALL-70T	TSOP

Industrial Range: -40°C to +85°C

Speed (ns)	Order Part No.	Package
70	IS62WV25616ALL-70TI	TSOP
70	IS62WV25616ALL-70BI	mini BGA (6mmx8mm)

IS62WV25616BLL (2.5V - 3.6V)

Commercial Range: 0°C to +70°C

Speed (ns)	Order Part No.	Package
55	IS62WV25616BLL-55T	TSOP
70	IS62WV25616BLL-70T	TSOP

Industrial Range: -40°C to +85°C

Speed (ns)	Order Part No.	Package
55	IS62WV25616BLL-55TI	TSOP
55	IS62WV25616BLL-55TLI	TSOP, Lead-free
55	IS62WV25616BLL-55BI	mini BGA (6mmx8mm)
55	IS62WV25616BLL-55BLI	mini BGA (6mmx8mm), Lead-free



	TITLE	44L 400mil TSOP-2 Package Outline	REV.	F	DATE	06/04/2008
--	--------------	---	-------------	----------	-------------	------------

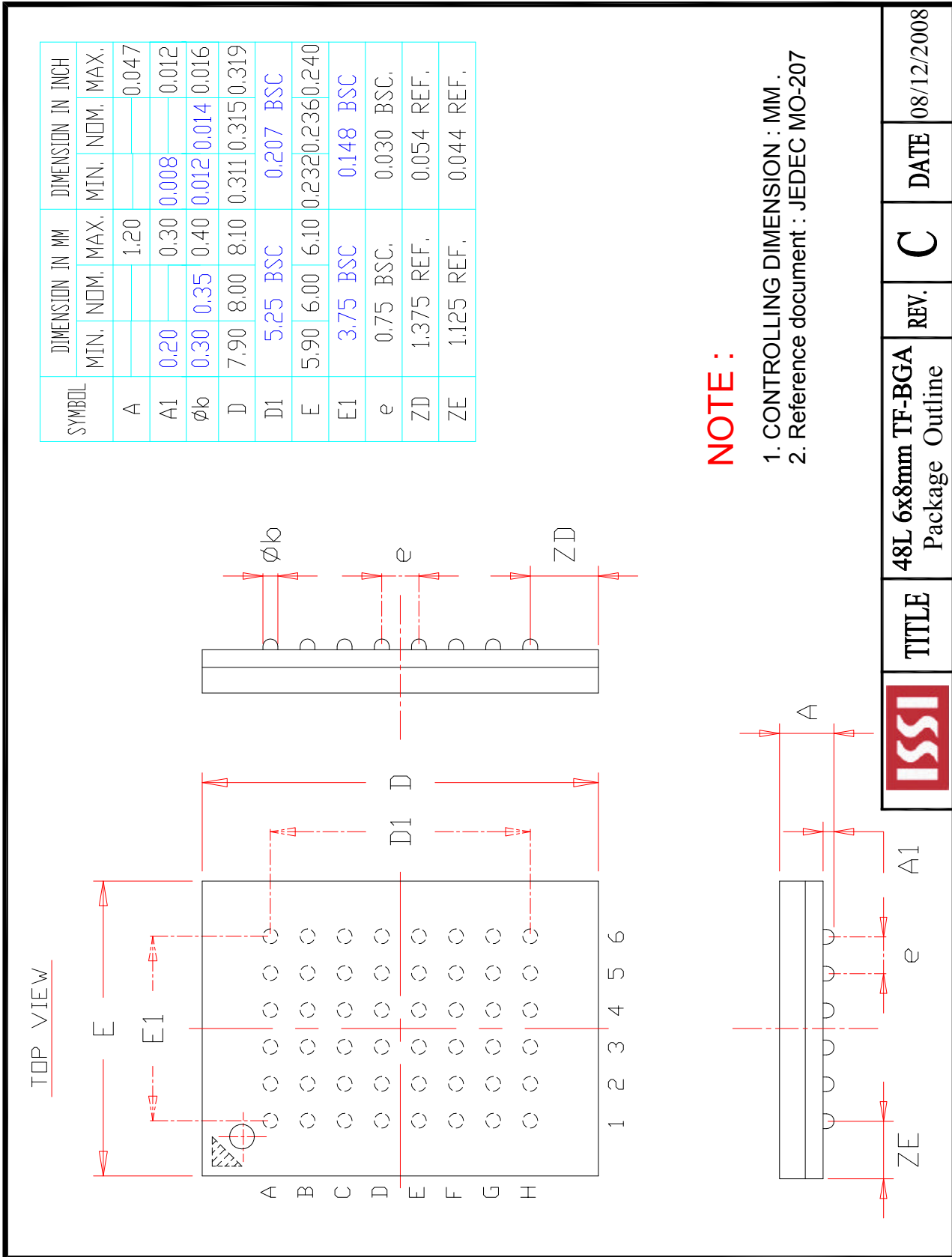

	TITLE	48L 6x8mm TF-BGA Package Outline	REV.	C	DATE	08/12/2008
--	-------	----------------------------------	------	---	------	------------



Компания «ЭлектроПласт» предлагает заключение долгосрочных отношений при поставках импортных электронных компонентов на взаимовыгодных условиях!

Наши преимущества:

- Оперативные поставки широкого спектра электронных компонентов отечественного и импортного производства напрямую от производителей и с крупнейших мировых складов;
- Поставка более 17-ти миллионов наименований электронных компонентов;
- Поставка сложных, дефицитных, либо снятых с производства позиций;
- Оперативные сроки поставки под заказ (от 5 рабочих дней);
- Экспресс доставка в любую точку России;
- Техническая поддержка проекта, помощь в подборе аналогов, поставка прототипов;
- Система менеджмента качества сертифицирована по Международному стандарту ISO 9001;
- Лицензия ФСБ на осуществление работ с использованием сведений, составляющих государственную тайну;
- Поставка специализированных компонентов (Xilinx, Altera, Analog Devices, Intersil, Interpoint, Microsemi, Aeroflex, Peregrine, Syfer, Eurofarad, Texas Instrument, Miteq, Cobham, E2V, MA-COM, Hittite, Mini-Circuits, General Dynamics и др.);

Помимо этого, одним из направлений компании «ЭлектроПласт» является направление «Источники питания». Мы предлагаем Вам помощь Конструкторского отдела:

- Подбор оптимального решения, техническое обоснование при выборе компонента;
- Подбор аналогов;
- Консультации по применению компонента;
- Поставка образцов и прототипов;
- Техническая поддержка проекта;
- Защита от снятия компонента с производства.



Как с нами связаться

Телефон: 8 (812) 309 58 32 (многоканальный)

Факс: 8 (812) 320-02-42

Электронная почта: org@eplast1.ru

Адрес: 198099, г. Санкт-Петербург, ул. Калинина, дом 2, корпус 4, литера А.