

LB11867RV

Variable Speed Single-phase Full-wave Pre-driver for Fan Motor

Monolithic Digital IC

Overview

LB11867RV is a single-phase bipolar driving motor pre-driver with the variable speed function compatible with external PWM signal. With a few external parts, a highly-efficient and highly-silent variable drive fan motor with low power consumption can be achieved. This product is best suited for driving of the server requiring large air flow and large current and the fan motor of consumer appliances.

Features

- Single-phase Full-wave Driving Pre-driver
 - ⇒ Low-saturation Drive Using External PMOS–NMOS Enables High-efficiency Low Power-consumption Drive
- Variable Speed Control Possible with External PWM Input
 - ⇒ Separately-excited Upper Direct PWM (f =30 kHz) Control Method Ensures Highly Silent Speed Control
- Current Limiting Circuit Incorporated
 - ⇒ Chopper Type Current Limiting Made at Startup and during Lock
- Reactive Current Cut Circuit Incorporated
 - ⇒ Reactive Current before Phase Changeover is Cut, Ensuring Highly Silent and Low Power-consumption Drive
- Minimum Speed Setting Pin
 - ⇒ Minimum Speed can be Set by Setting the Resistance
- Soft Start Setting Pin
- Lock Protection and Automatic Reset Circuits Incorporated
- RD (Lock Detection) Output
- Thermal Shutdown Circuit Incorporated

Typical Applications

- Computing & Peripherals
- Industrial
- Server
- Vending Machine



ON Semiconductor®

www.onsemi.com

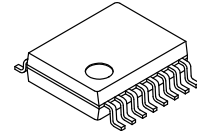

SSOP16
CASE 565AM

MARKING DIAGRAM

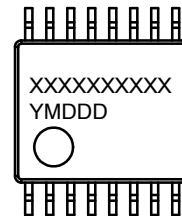

XXXX = Specific Device Code
Y = Year
M = Month
DDD = Additional Traceability Data

PIN ASSIGNMENT

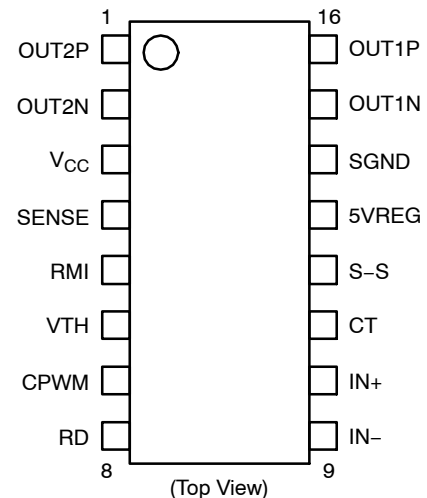

ORDERING INFORMATION

See detailed ordering and shipping information on page 9 of this data sheet.

LB11867RV

SPECIFICATIONS

ABSOLUTE MAXIMUM RATINGS (T_A = 25°C)

Symbol	Parameter	Conditions	Ratings	Unit
V _{CC} max	V _{CC} Pin Maximum Supply Voltage		18	V
I _{OUTN} max	OUTN Pin Maximum Output Current		20	mA
I _{OUTP} max	OUTP Pin Maximum Sink Current		20	mA
V _{OUT} max	OUT Pin Output Withstand Voltage		18	V
V _{VTH, VRMI} max	V _{VTH} , RMI Pins Withstand Voltage		7	V
V _{S-S} max	S-S Pin Withstand Voltage		7	V
V _{RD} max	RD Output Pin Withstand Voltage		19	V
I _{RD} max	RD Pin Maximum Output Current		10	mA
I _{5VREG} max	5VREG Pin Maximum Output Current		20	mA
P _d max	Allowable Power Dissipation	With specified substrate (Note 1)	800	mW
T _{opr}	Operating Temperature	(Note 2)	-30 to 95	°C
T _{stg}	Storage Temperature		-55 to 150	°C

Stresses exceeding those listed in the Maximum Ratings table may damage the device. If any of these limits are exceeded, device functionality should not be assumed, damage may occur and reliability may be affected.

1. Specified substrate: 114.3 mm × 76.1 mm × 1.6 mm, glass epoxy board.
2. T_j max = 150°C must not be exceeded.

RECOMMENDED OPERATING CONDITIONS (T_A = 25°C)

Symbol	Parameter	Conditions	Ratings	Unit
V _{CC}	V _{CC} Supply Voltage		5.5 to 16	V
V _{VTH, RMI}	V _{VTH} , RMI Input Voltage Range		0 to 5	V
V _{ICM}	Hall Input Common-phase Input Voltage Range		0.2 to 3	V

Functional operation above the stresses listed in the Recommended Operating Ranges is not implied. Extended exposure to stresses beyond the Recommended Operating Ranges limits may affect device reliability.

ELECTRICAL CHARACTERISTICS (T_A = 25°C, V_{CC} = 12 V)

Symbol	Parameter	Conditions	Min	Typ	Max	Unit
I _{CC1}	Circuit Current	During drive	5.5	7.5	9.5	mA
I _{CC2}		During lock protection	5.5	7.5	9.5	mA
V _{5VREG}	5VREG Voltage	I _{5VREG} = 5 mA	4.80	4.95	5.10	V
V _{LIM}	Current Limiting Voltage		185	200	215	mV
V _{CPWMH}	CPWM Pin "H" Level Voltage		2.8	3.0	3.2	V
V _{CPWML}	CPWM Pin "L" Level Voltage		0.9	1.1	1.3	V
I _{CPWM1}	CPWM Pin Charge Current	V _{CPWM} = 0.5 V	24	30	36	μA
I _{CPWM2}	CPWM Pin Discharge Current	V _{CPWM} = 3.5 V	21	27	33	μA
FPWM	CPWM Oscillation Frequency	C = 220 pF	-	30	-	kHz
V _{CTH}	CT Pin "H" Level Voltage		2.8	3.0	3.2	V
V _{CTL}	CT Pin "L" Level Voltage		0.9	1.1	1.3	V
I _{CT1}	CT Pin Charge Current	V _{CT} = 0.5 V	1.6	2.0	2.5	μA
I _{CT2}	CT Pin Discharge Current	V _{CT} = 3.5 V	0.16	0.20	0.25	μA
R _{CT}	CT Pin Charge/Discharge Ratio	I _{CT1} /I _{CT2}	8	10	12	times
I _{S-S}	S-S Pin Discharge Current	V _{S-S} = 1 V	0.4	0.5	0.6	μA

LB11867RV

ELECTRICAL CHARACTERISTICS ($T_A = 25^\circ\text{C}$, $V_{CC} = 12\text{ V}$) (continued)

Symbol	Parameter	Conditions	Min	Typ	Max	Unit
V_{ONH}	OUTN Output H-level Voltage	$I_O = 10\text{ mA}$	-	$V_{CC}-0.85$	$V_{CC}-1.00$	V
V_{ONL}	OUTN Output L-level Voltage	$I_O = 10\text{ mA}$	-	0.9	1.00	V
V_{OPL}	OUTP Output L-level Voltage	$I_O = 10\text{ mA}$	-	0.5	0.65	V
VHN	Hall Input Sensitivity	I_{N^+} , I_{N^-} differential voltage (including offset and hysteresis)	-	± 10	± 20	mV
$V_{RD L}$	RD Output L-level Voltage	$I_{RD} = 5\text{ mA}$	-	0.15	0.30	V
$I_{RD L}$	RD Pin Leakage Current	$V_{RD} = 19\text{ V}$	-	-	20	μA
IVTH/IRMI	VTH/RMI Pin Bias Current	CPWM = VTH/RMI = 2 V	-	-	0.1	μA

Product parametric performance is indicated in the Electrical Characteristics for the listed test conditions, unless otherwise noted. Product performance may not be indicated by the Electrical Characteristics if operated under different conditions.

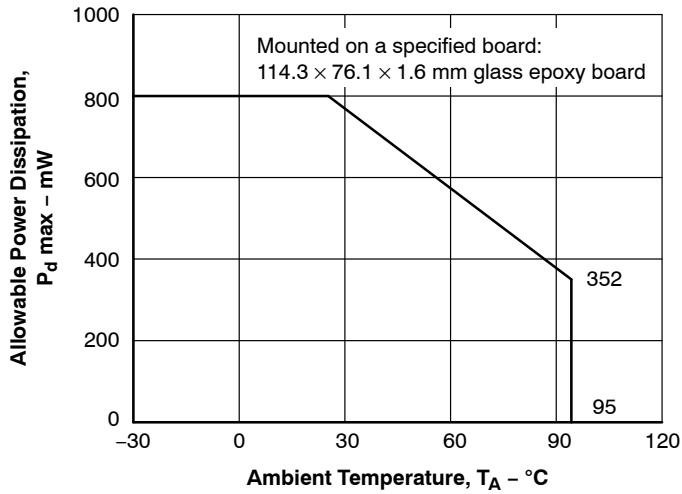

Figure 1. $P_d \text{ max} - T_A$

LB11867RV

BLOCK DIAGRAM

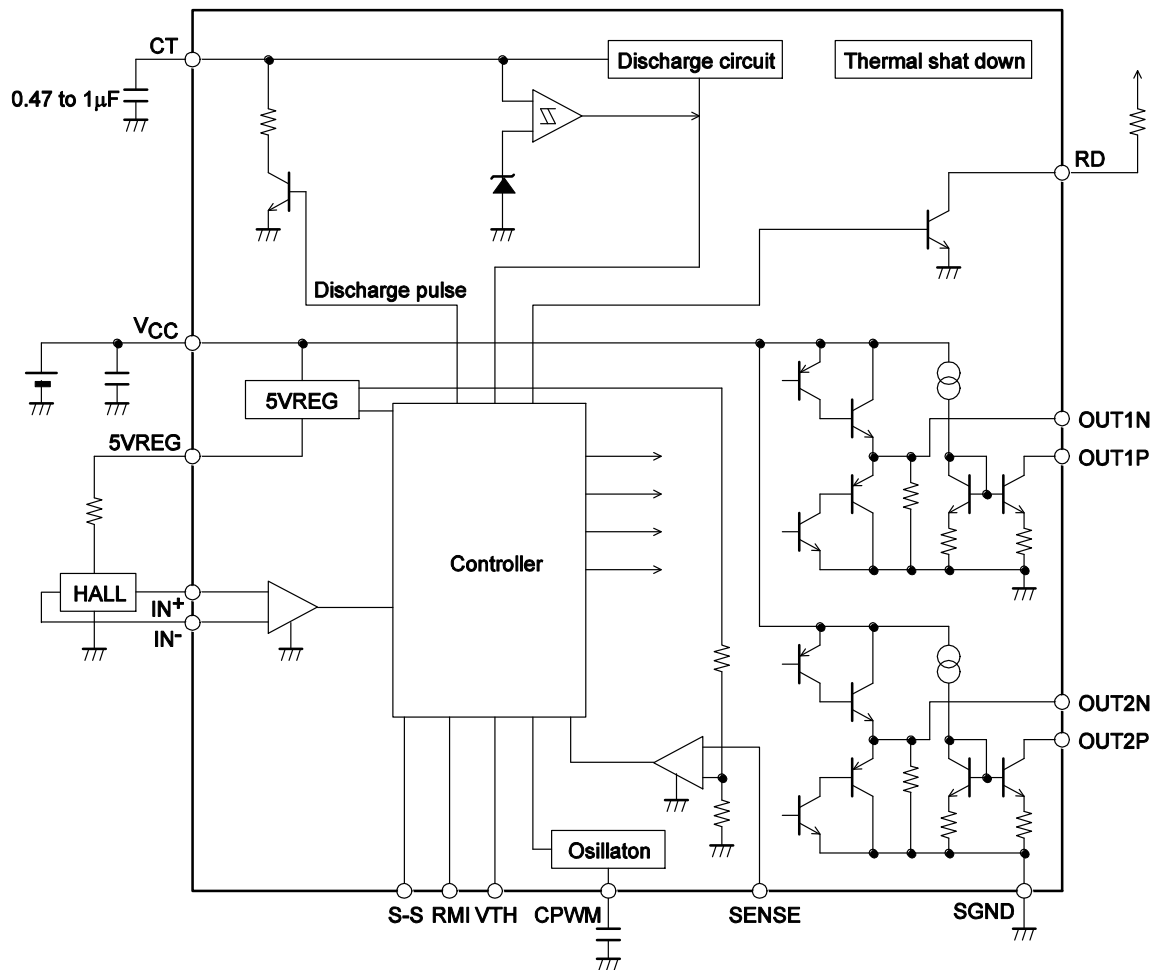

Figure 2. Block Diagram

TRUTH TABLE - DRIVE LOCK CPWM = H VTH, RMI, S-S = L

IN-	IN+	CT	OUT1P	OUT1N	OUT2P	OUT2N	FG	Mode
H	L	L	L	L	OFF	H	L	OUT1 → 2 drive
L	H		OFF	H	L	L	L	OUT2 → 1 drive
H	L	H	OFF	L	OFF	H	OFF	Lock protection
L	H		OFF	H	OFF	L	OFF	

TRUTH TABLE - SPEED CONTROL CT, S-S = L

VTH, RMI	CPWM	IN-	IN+	OUT1P	OUT1N	OUT2P	OUT2N	Mode
L	H	H	L	L	L	OFF	H	OUT1 → 2 drive
		L	H	OFF	H	L	L	OUT2 → 1 drive
H	L	H	L	OFF	L	OFF	H	Regeneration mode
		L	H	OFF	H	OFF	L	

NOTE: For VTH, RMI, and S-S pins, refer to the timing chart.

APPLICATION CIRCUIT

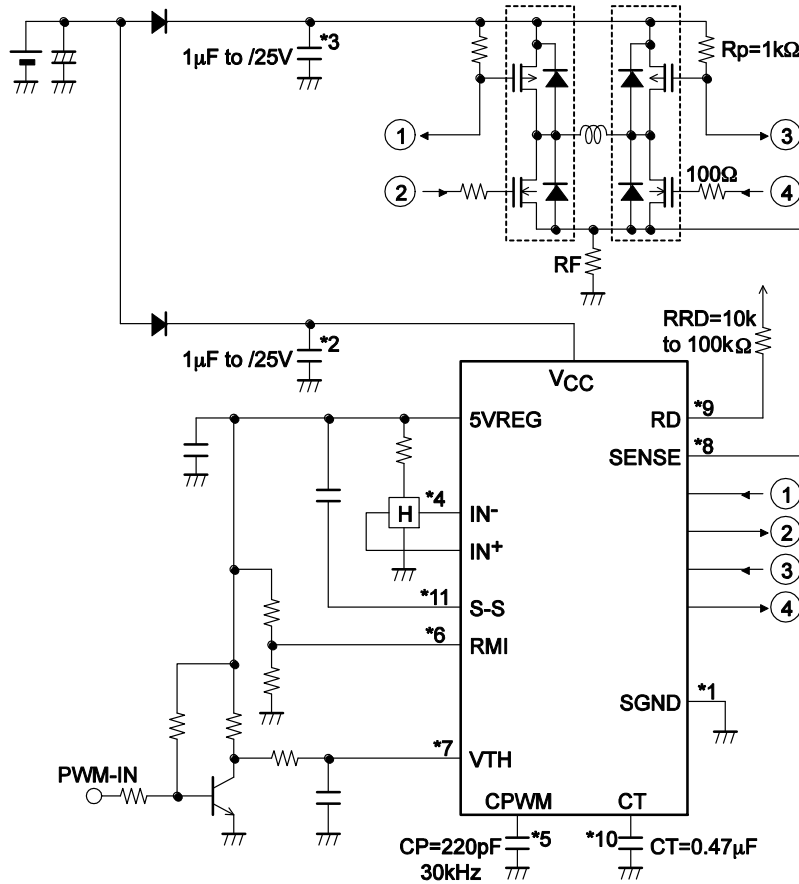

Figure 3. Application Circuit Example (12 V)

*1: Power-GND Wiring

SGND is connected to the control circuit power supply system.

*2: Power Stabilization Capacitor

For the power stabilization capacitor on the signal side, use the capacitance of 1 µF or more. Connect V_{CC} and GND with a thick and shortest pattern.

*3: Power Stabilization Capacitor on the Power Side

For the power stabilization capacitor on the power side, use the capacitance of 1 µF or more. Connect the power supply on the power side and GND with a thick and shortest pattern.

*4: IN⁺, IN⁻ Pins

Hall signal input pin.

Wiring should be short to prevent carrying of noise.

If noise is carried, insert the capacitor between IN⁺ and IN⁻ pins.

The Hall input circuit functions as a comparator with hysteresis (15 mV).

This also has a soft switch section with ±30 mV (input signal differential voltage).

It is also recommended that the Hall input level is minimum 100 mV(p-p).

*5: CPWM Pin

Pin to connect the capacitor for generation of the PWM basic frequency

The use of CP = 220 pF causes oscillation at f = 30 kHz, which is the basic frequency of PWM. As this is used also for the current limiting canceling signal, be sure to connect the capacitor even when the speed control is not made.

*6: RMI Pin

Minimum speed setting pin.

Perform pull-up with 5VREG when this pin is not to be used.

If the IC power supply is likely to be turned OFF first when the pin is used with external power supply, be sure to insert the current limiting resistor to prevent inflow of large current. (The same applies to the VTH pin.)

LB11867RV

*7: VTH Pin

Speed control pin.

Connect this pin to GND when it is not used (at full speed).

For the control method, refer to the timing chart.

For control with pulse input, insert the current limiting resistor and use the pin with the frequency of 20 kHz to 100 kHz (20 kHz to 50 kHz recommended).

*8: SENSE Pin

Current limiting detection pin.

When the pin voltage exceeds 0.2 V, the current is limited and the operation enters the lower regeneration mode.

Connect this pin to GND when it is not to be used.

*9: RD Pin

Lock detection pin.

In open collector output, L upon rotation and H when locked (using pull-up resistance).

Keep this pin open when it is not to be used.

*10: CT Pin

Pin to connect the lock detection capacitor.

The constant-current charge and discharge circuits incorporated cause locking when the pin voltage becomes 3.0 V and unlocking when it is 1.1 V.

Connect the pin to GND when it is not to be used (locking not necessary).

*11: S-S Pin

Pin to connect the soft-start setting capacitor.

Connect the capacitor between 5VREG and S-S pin.

This pin enables setting of the soft start time according to the capacity of the capacitor.

See the timing char.

Connect the pin to GND when it is not to be used.

CONTROL TIMING CHART (SPEED CONTROL)

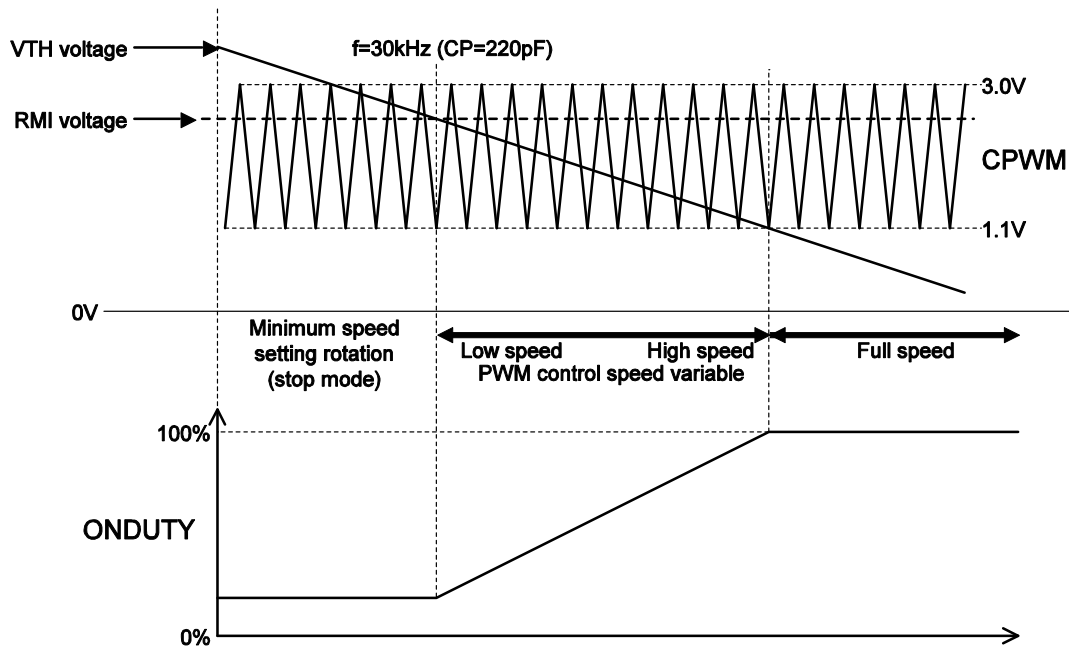

Figure 4. Control Timing Chart – Speed Control

1. Minimum Speed Setting (Stop) Mode
The low-speed fan rotation occurs at the minimum speed set with the RMI pin. When the minimum speed is not set (RMI pin pulled up to 5VREG), the motor stops.
2. Low Speed \leftrightarrow High Speed
PMW control is made by comparing the CPWM oscillation voltage (1.1 V \leftrightarrow 3.0 V) and VTH voltage.
Both upper and lower output TRs are turned ON

- when the VTH voltage is low. The upper output TR is turned OFF when the VTH voltage is high, regenerating the coil current in the lower TR. Therefore, as the VTH voltage decreases, the output ON-DUTY increases, causing increase in the coil current, raising the motor rotation speed.
3. Full Speed Mode
The full speed mode becomes effective when the VTH voltage is 1.1 V or less. (Set VTH = GND when the speed control is not to be made.)

CONTROL TIMING CHART (SOFT START)

1. At $V_{TH} < RMI$ Voltage

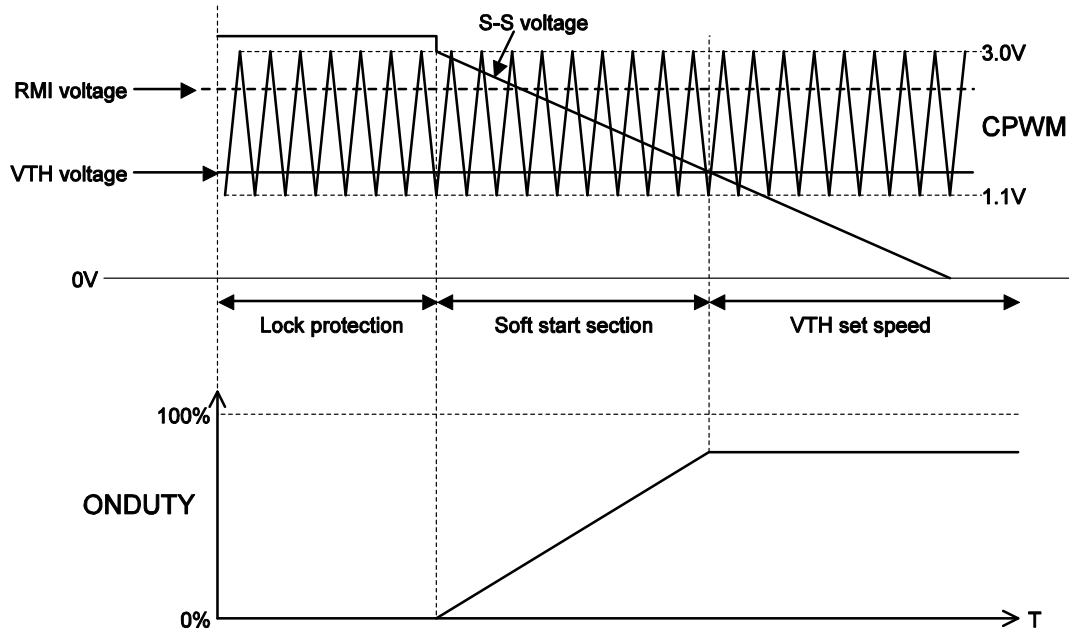

Figure 5. At $V_{TH} < RMI$ Voltage

2. At $V_{TH} > RMI$ Voltage

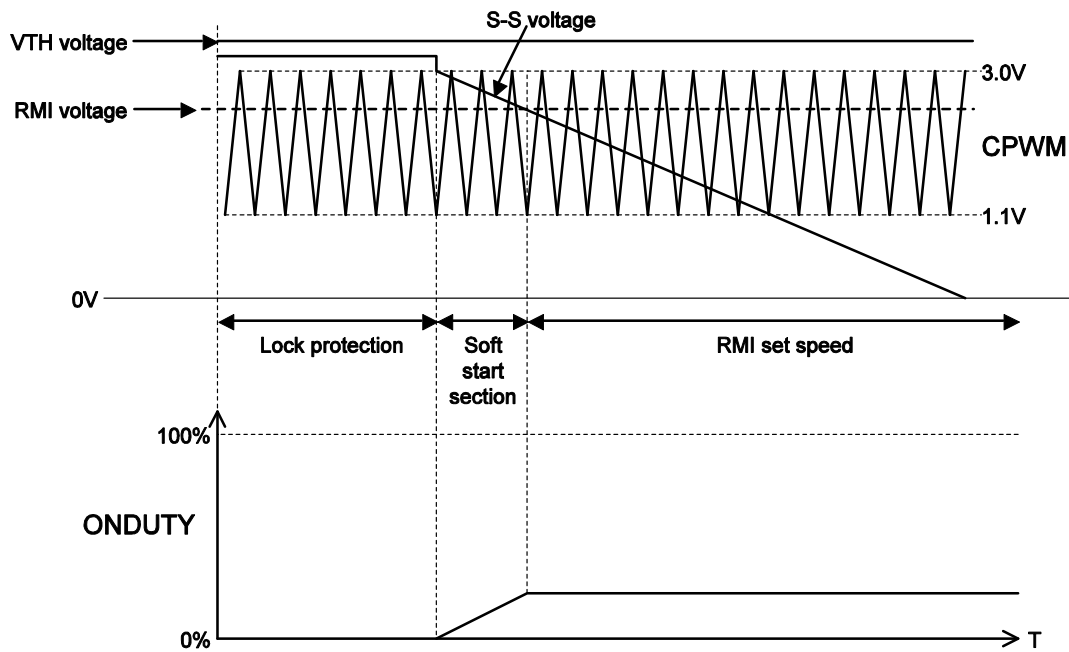

Figure 6. At $V_{TH} > RMI$ Voltage

Adjust the S-S pin voltage gradient by means of the capacitance of the capacitor between the S-S pin and 5VREG. Recommended capacitor: 0.1 μ F to 1 μ F

LB11867RV

ORDERING INFORMATION

Device	Package	Wire Bond	Shipping† (Qty / Packing)
LB11867RV-MPB-H	SSOP16 (225mil) (Pb-Free / Halogen Free)	Au-wire	90 / Fan-Fold
LB11867RV-TLM-E	SSOP16 (225mil) (Pb-Free)	Au-wire	2,000 / Tape & Reel
LB11867RV-TLM-H	SSOP16 (225mil) (Pb-Free / Halogen Free)	Au-wire	2,000 / Tape & Reel
LB11867RV-W-AH	SSOP16 (225mil) (Pb-Free / Halogen Free)	Cu-wire	2,000 / Tape & Reel

†For information on tape and reel specifications, including part orientation and tape sizes, please refer to our Tape and Reel Packaging Specifications Brochure, [BRD8011/D](#).

MECHANICAL CASE OUTLINE

PACKAGE DIMENSIONS

ON Semiconductor®

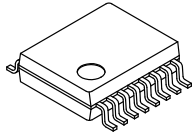

SSOP16 (225mil) CASE 565AM ISSUE A

DATE 23 OCT 2013

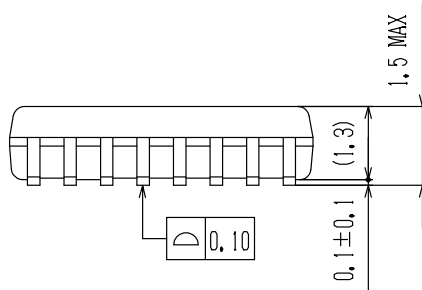
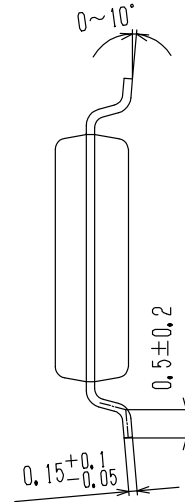
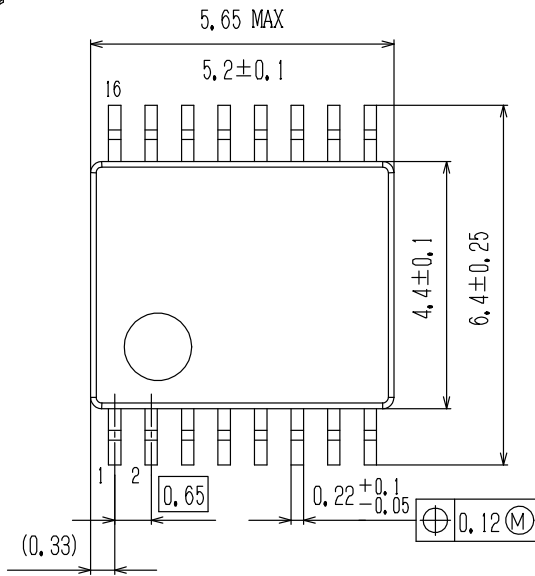

SOLDERING FOOTPRINT*

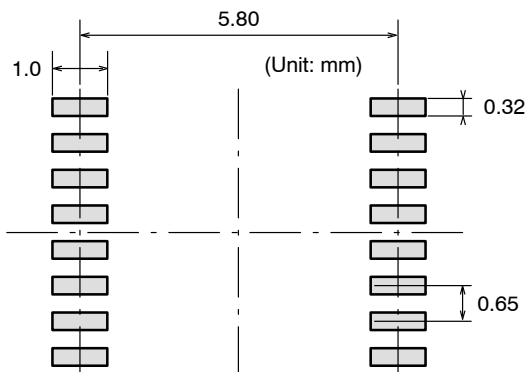

NOTE: The measurements are not to guarantee but for reference only.

*For additional information on our Pb-Free strategy and soldering details, please download the ON Semiconductor Soldering and Mounting Techniques Reference Manual, SOLDERRM/D.

GENERIC MARKING DIAGRAM*

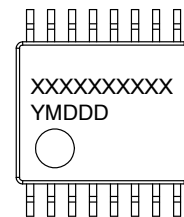

XXXXX = Specific Device Code
Y = Year
M = Month
DDD = Additional Traceability Data

*This information is generic. Please refer to device data sheet for actual part marking. Pb-Free indicator, "G" or microdot "▪", may or may not be present.

DOCUMENT NUMBER:	98AON66065E	Electronic versions are uncontrolled except when accessed directly from the Document Repository. Printed versions are uncontrolled except when stamped "CONTROLLED COPY" in red.
STATUS:	ON SEMICONDUCTOR STANDARD	
NEW STANDARD:		
DESCRIPTION:	SSOP16 (225MIL)	PAGE 1 OF 2



ISSUE	REVISION	DATE
O	RELEASED FOR PRODUCTION FROM SANYO ENACT# S-010 TO ON SEMICONDUCTOR. REQ. BY D. TRUHITTE.	30 JAN 2012
A	ADDED MARKING AND SOLDER FOOTPRINT INFORMATION. REQ. BY D. TRUHITTE.	23 OCT 2013

ON Semiconductor and ON are registered trademarks of Semiconductor Components Industries, LLC (SCILLC). SCILLC reserves the right to make changes without further notice to any products herein. SCILLC makes no warranty, representation or guarantee regarding the suitability of its products for any particular purpose, nor does SCILLC assume any liability arising out of the application or use of any product or circuit, and specifically disclaims any and all liability, including without limitation special, consequential or incidental damages. "Typical" parameters which may be provided in SCILLC data sheets and/or specifications can and do vary in different applications and actual performance may vary over time. All operating parameters, including "Typicals" must be validated for each customer application by customer's technical experts. SCILLC does not convey any license under its patent rights nor the rights of others. SCILLC products are not designed, intended, or authorized for use as components in systems intended for surgical implant into the body, or other applications intended to support or sustain life, or for any other application in which the failure of the SCILLC product could create a situation where personal injury or death may occur. Should Buyer purchase or use SCILLC products for any such unintended or unauthorized application, Buyer shall indemnify and hold SCILLC and its officers, employees, subsidiaries, affiliates, and distributors harmless against all claims, costs, damages, and expenses, and reasonable attorney fees arising out of, directly or indirectly, any claim of personal injury or death associated with such unintended or unauthorized use, even if such claim alleges that SCILLC was negligent regarding the design or manufacture of the part. SCILLC is an Equal Opportunity/Affirmative Action Employer. This literature is subject to all applicable copyright laws and is not for resale in any manner.

ON Semiconductor and  are trademarks of Semiconductor Components Industries, LLC dba ON Semiconductor or its subsidiaries in the United States and/or other countries. ON Semiconductor owns the rights to a number of patents, trademarks, copyrights, trade secrets, and other intellectual property. A listing of ON Semiconductor's product/patent coverage may be accessed at www.onsemi.com/site/pdf/Patent-Marking.pdf. ON Semiconductor reserves the right to make changes without further notice to any products herein. ON Semiconductor makes no warranty, representation or guarantee regarding the suitability of its products for any particular purpose, nor does ON Semiconductor assume any liability arising out of the application or use of any product or circuit, and specifically disclaims any and all liability, including without limitation special, consequential or incidental damages. Buyer is responsible for its products and applications using ON Semiconductor products, including compliance with all laws, regulations and safety requirements or standards, regardless of any support or applications information provided by ON Semiconductor. "Typical" parameters which may be provided in ON Semiconductor data sheets and/or specifications can and do vary in different applications and actual performance may vary over time. All operating parameters, including "Typicals" must be validated for each customer application by customer's technical experts. ON Semiconductor does not convey any license under its patent rights nor the rights of others. ON Semiconductor products are not designed, intended, or authorized for use as a critical component in life support systems or any FDA Class 3 medical devices or medical devices with a same or similar classification in a foreign jurisdiction or any devices intended for implantation in the human body. Should Buyer purchase or use ON Semiconductor products for any such unintended or unauthorized application, Buyer shall indemnify and hold ON Semiconductor and its officers, employees, subsidiaries, affiliates, and distributors harmless against all claims, costs, damages, and expenses, and reasonable attorney fees arising out of, directly or indirectly, any claim of personal injury or death associated with such unintended or unauthorized use, even if such claim alleges that ON Semiconductor was negligent regarding the design or manufacture of the part. ON Semiconductor is an Equal Opportunity/Affirmative Action Employer. This literature is subject to all applicable copyright laws and is not for resale in any manner.

PUBLICATION ORDERING INFORMATION

LITERATURE FULFILLMENT:

Literature Distribution Center for ON Semiconductor
19521 E. 32nd Pkwy, Aurora, Colorado 80011 USA
Phone: 303-675-2175 or 800-344-3860 Toll Free USA/Canada
Fax: 303-675-2176 or 800-344-3867 Toll Free USA/Canada
Email: orderlit@onsemi.com

N. American Technical Support: 800-282-9855 Toll Free
USA/Canada
Europe, Middle East and Africa Technical Support:
Phone: 421 33 790 2910

ON Semiconductor Website: www.onsemi.com

Order Literature: <http://www.onsemi.com/orderlit>

For additional information, please contact your local
Sales Representative



Компания «ЭлектроПласт» предлагает заключение долгосрочных отношений при поставках импортных электронных компонентов на взаимовыгодных условиях!

Наши преимущества:

- Оперативные поставки широкого спектра электронных компонентов отечественного и импортного производства напрямую от производителей и с крупнейших мировых складов;
- Поставка более 17-ти миллионов наименований электронных компонентов;
- Поставка сложных, дефицитных, либо снятых с производства позиций;
- Оперативные сроки поставки под заказ (от 5 рабочих дней);
- Экспресс доставка в любую точку России;
- Техническая поддержка проекта, помощь в подборе аналогов, поставка прототипов;
- Система менеджмента качества сертифицирована по Международному стандарту ISO 9001;
- Лицензия ФСБ на осуществление работ с использованием сведений, составляющих государственную тайну;
- Поставка специализированных компонентов (Xilinx, Altera, Analog Devices, Intersil, Interpoint, Microsemi, Aeroflex, Peregrine, Syfer, Eurofarad, Texas Instrument, Miteq, Cobham, E2V, MA-COM, Hittite, Mini-Circuits, General Dynamics и др.);

Помимо этого, одним из направлений компании «ЭлектроПласт» является направление «Источники питания». Мы предлагаем Вам помощь Конструкторского отдела:

- Подбор оптимального решения, техническое обоснование при выборе компонента;
- Подбор аналогов;
- Консультации по применению компонента;
- Поставка образцов и прототипов;
- Техническая поддержка проекта;
- Защита от снятия компонента с производства.



Как с нами связаться

Телефон: 8 (812) 309 58 32 (многоканальный)

Факс: 8 (812) 320-02-42

Электронная почта: org@eplast1.ru

Адрес: 198099, г. Санкт-Петербург, ул. Калинина, дом 2, корпус 4, литера А.