

- **Controlled Baseline**
  - One Assembly/Test Site, One Fabrication Site
- **Extended Temperature Performance of –55°C to 125°C**
- **Enhanced Diminishing Manufacturing Sources (DMS) Support**
- **Enhanced Product Change Notification**
- **Qualification Pedigree†**
- **ESD Protection Exceeds 2000 V Per MIL-STD-883, Method 3015; Exceeds 200 V Using Machine Model (C = 200 pF, R = 0)**
- **Triple Supervisory Circuits for DSP and Processor-Based Systems**
- **Power-On Reset Generator With Fixed Delay Time of 200 ms, No External Capacitor Needed**
- **Temperature-Compensated Voltage Reference**
- **Maximum Supply Current of 40 μA**
- **Supply Voltage Range . . . 2 V to 6 V**
- **Defined  $\overline{\text{RESET}}$  Output from  $V_{\text{DD}} \geq 1.1 \text{ V}$**
- **SO-8 and MSOP-8 Packages**

† Component qualification in accordance with JEDEC and industry standards to ensure reliable operation over an extended temperature range. This includes, but is not limited to, Highly Accelerated Stress Test (HAST) or biased 85/85, temperature cycle, autoclave or unbiased HAST, electromigration, bond intermetallic life, and mold compound life. Such qualification testing should not be viewed as justifying use of this component beyond specified performance and environmental limits.

D or DGN PACKAGE  
(TOP VIEW)

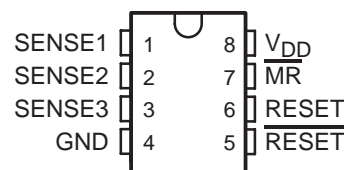

## typical applications

Figure 1 lists some of the typical applications for the TPS3307 family, and a schematic diagram for a processor-based system application. This application uses Texas Instruments part numbers TPS3307-18 and SMJ320C6201B.

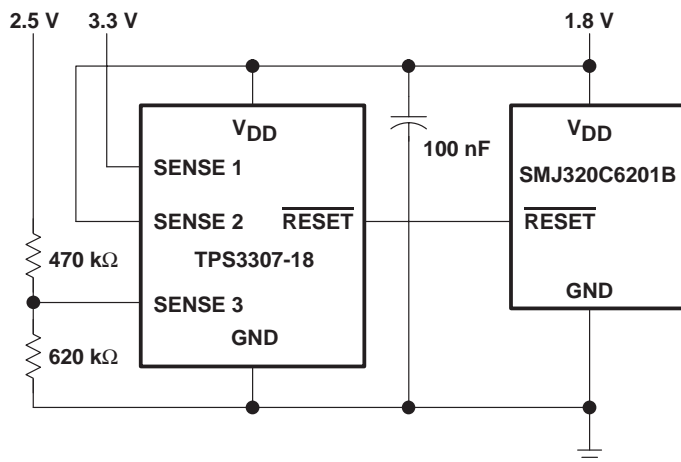

- **Military applications using DSPs, Microcontrollers or Microprocessors**
- **Industrial Equipment**
- **Programmable Controls**
- **Military Systems**

Figure 1. Applications Using the TPS3307-18

## description

The TPS3307-xx family is a series of micropower supply voltage supervisors designed for circuit initialization primarily in DSP and processor-based systems which require more than one supply voltage.

The TPS3307-18 and TPS3307-33 are designed for monitoring three independent supply voltages: 3.3 V/1.8 V/adj and 5V/3.3V/adj, respectively. The adjustable SENSE input allows the monitoring of any supply voltage >1.25 V.



Please be aware that an important notice concerning availability, standard warranty, and use in critical applications of Texas Instruments semiconductor products and disclaimers thereto appears at the end of this data sheet.

PRODUCTION DATA information is current as of publication date. Products conform to specifications per the terms of Texas Instruments standard warranty. Production processing does not necessarily include testing of all parameters.

**TEXAS  
INSTRUMENTS**

POST OFFICE BOX 655303 • DALLAS, TEXAS 75265

Copyright © 2005, Texas Instruments Incorporated

# TPS3307-18-EP, TPS3307-33-EP TRIPLE PROCESSOR SUPERVISORS

SGLS140A – NOVEMBER 2002 – REVISED AUGUST 2005

## description (continued)

The various supply voltage supervisors are designed to monitor the nominal supply voltage as shown in the following supply voltage monitoring table.

**SUPPLY VOLTAGE MONITORING**

DEVICE	NOMINAL SUPERVISED VOLTAGE			THRESHOLD VOLTAGE (TYP)		
	SENSE1	SENSE2	SENSE3	SENSE1	SENSE2	SENSE3
TPS3307-18	3.3 V	1.8 V	User defined	2.93 V	1.68 V	1.25 V†
TPS3307-33	5 V	3.3 V	User defined	4.55 V	2.93 V	1.25 V†

† The actual sense voltage has to be adjusted by an external resistor divider according to the application requirements.

During power-on,  $\overline{\text{RESET}}$  is asserted when the supply voltage  $V_{DD}$  becomes higher than 1.1 V. Thereafter, the supply voltage supervisor monitors the SENSEn inputs and keeps  $\overline{\text{RESET}}$  active as long as SENSEn remain below the threshold voltage  $V_{IT+}$ .

An internal timer delays the return of the  $\overline{\text{RESET}}$  output to the inactive state (high) to ensure proper system reset. The delay time,  $t_{dtyp} = 200$  ms, starts after all SENSEn inputs have risen above the threshold voltage  $V_{IT+}$ . When the voltage at any SENSE input drops below the threshold voltage  $V_{IT-}$ , the  $\overline{\text{RESET}}$  output becomes active (low) again.

The TPS3307-xx family of devices incorporates a manual reset input,  $\overline{\text{MR}}$ . A low level at  $\overline{\text{MR}}$  causes  $\overline{\text{RESET}}$  to become active. In addition to the active-low  $\overline{\text{RESET}}$  output, the TPS3307-xx family includes an active-high RESET output.

The devices are available in either 8-pin MSOP or a standard 8-pin SO packages and are characterized for operation over a temperature range of  $-55^{\circ}\text{C}$  to  $125^{\circ}\text{C}$ .

## ORDERING INFORMATION

T <sub>A</sub>	PACKAGE‡		ORDERABLE PART NUMBER	TOP-SIDE MARKING
$-55^{\circ}\text{C}$ to $125^{\circ}\text{C}$	Small Outline (D)	Tape and Reel	TPS3307-18MDREP	30718E
	PowerPad $\mu$ -Small Outline (DGN)	Tape and Reel	TPS3307-33MDGNREP	BNP

‡ Package drawings, standard packing quantities, thermal data, symbolization, and PCB design guidelines are available at [www.ti.com/sc/package](http://www.ti.com/sc/package).

## FUNCTION/TRUTH TABLES

$\overline{\text{MR}}$	SENSE1 > $V_{IT1}$	SENSE2 > $V_{IT2}$	SENSE3 > $V_{IT3}$	$\overline{\text{RESET}}$	RESET
L	X	X	X	L	H
H	0	0	0	L	H
H	0	0	1	L	H
H	0	1	0	L	H
H	0	1	1	L	H
H	1	0	0	L	H
H	1	0	1	L	H
H	1	1	0	L	H
H	1	1	1	H	L

X = Don't care



functional block diagram

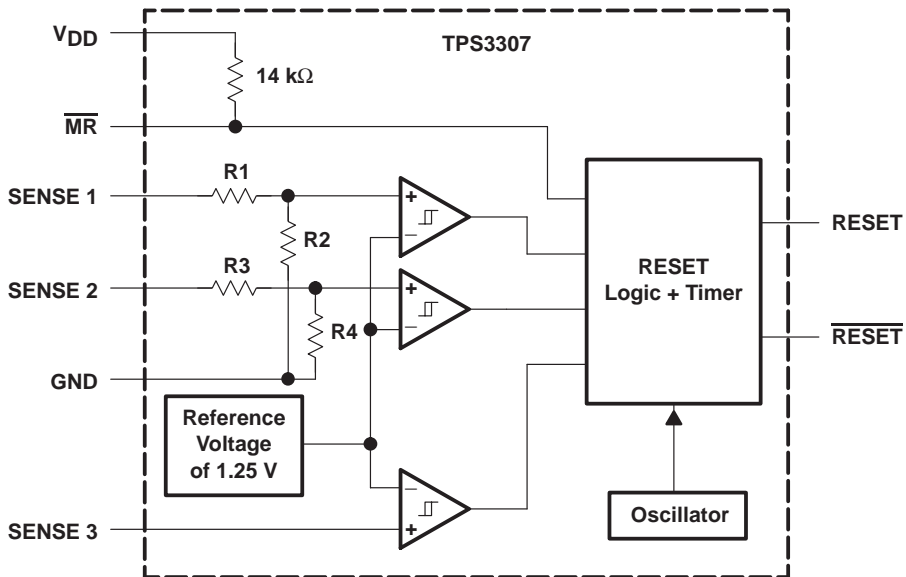

timing diagram

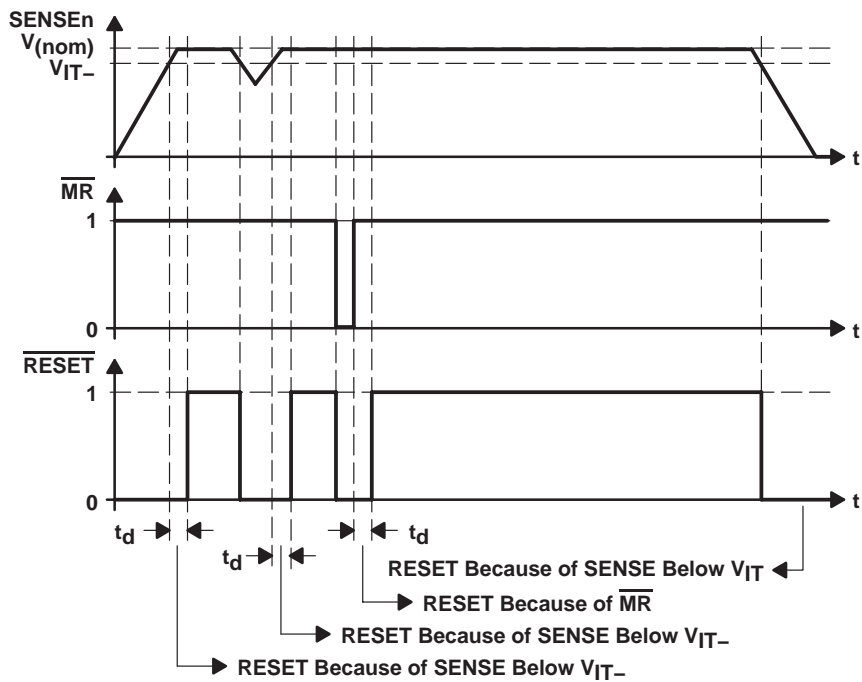

# TPS3307-18-EP, TPS3307-33-EP TRIPLE PROCESSOR SUPERVISORS

SGLS140A – NOVEMBER 2002 – REVISED AUGUST 2005

## absolute maximum ratings over operating free-air temperature range (unless otherwise noted)†

Supply voltage, $V_{DD}$ (see Note 1)	7 V
All other pins (see Note 1)	-0.3 V to 7 V
Maximum low output current, $I_{OL}$	5 mA
Maximum high output current, $I_{OH}$	-5 mA
Input clamp current, $I_{IK}$ ( $V_I < 0$ or $V_I > V_{DD}$ )	$\pm 20$ mA
Output clamp current, $I_{OK}$ ( $V_O < 0$ or $V_O > V_{DD}$ )	$\pm 20$ mA
Maximum junction temperature, $T_J$	150°C
Package thermal impedance, $\theta_{JA}$ (see Note 2) D package	126°C/W
DGN package	58.4°C/W
Operating free-air temperature range, $T_A$	-55°C to 125°C
Storage temperature range, $T_{stg}$ (see Note 3)	-65°C to 150°C
Soldering temperature	260°C

† Stresses beyond those listed under “absolute maximum ratings” may cause permanent damage to the device. These are stress ratings only, and functional operation of the device at these or any other conditions beyond those indicated under “recommended operating conditions” is not implied. Exposure to absolute-maximum-rated conditions for extended periods may affect device reliability.

NOTE 1: All voltage values are with respect to GND. For reliable operation the device must not be operated at 7 V for more than  $t = 1000$  h continuously.

NOTE 2: The thermal impedance,  $\theta_{JA}$ , for the D package is determined for JEDEC high-K PCB (JESD51-7). The thermal impedance value for the DGN package is determined for Texas Instruments recommended assembly for PowerPAD packages. See Texas Instruments technical briefs SLMA002 and SLMA004 for more information about utilizing the PowerPAD thermally enhanced package. Thermal impedance,  $\theta_{JA}$ , values for the D and DGN packages using JEDEC low-K PCB (JESD51-3) are 215°C/W and 296°C/W, respectively.

NOTE 3: Long-term, high-temperature storage and/or extended use at maximum recommended operating conditions may result in a reduction of overall device life. See <http://www.ti.com/sc/ep> for more information.

## recommended operating conditions at specified temperature range

	MIN	MAX	UNIT
Supply voltage, $V_{DD}$	2	6	V
Input voltage at $\overline{MR}$ and SENSE3, $V_I$	0	$V_{DD}+0.3$	V
Input voltage at SENSE1 and SENSE2, $V_I$	0	$(V_{DD}+0.3)V_{IT}/1.25$ V	V
High-level input voltage at $\overline{MR}$ , $V_{IH}$	$0.7 \times V_{DD}$		V
Low-level input voltage at $\overline{MR}$ , $V_{IL}$	$0.3 \times V_{DD}$		V
Input transition rise and fall rate at $\overline{MR}$ , $\Delta t/\Delta V$	50		ns/V
Operating free-air temperature range, $T_A$	-55	125	°C



# TPS3307-18-EP, TPS3307-33-EP TRIPLE PROCESSOR SUPERVISORS

SGLS140A – NOVEMBER 2002 – REVISED AUGUST 2005

**electrical characteristics over recommended operating free-air temperature range (unless otherwise noted)**

PARAMETER		TEST CONDITIONS	MIN	TYP	MAX	UNIT		
V <sub>OH</sub>	High-level output voltage	V <sub>DD</sub> = 2 V to 6 V, I <sub>OH</sub> = -20 μA	V <sub>DD</sub> - 0.2 V			V		
		V <sub>DD</sub> = 3.3 V, I <sub>OH</sub> = -2 mA	V <sub>DD</sub> - 0.4 V					
		V <sub>DD</sub> = 6 V, I <sub>OH</sub> = -3 mA	V <sub>DD</sub> - 0.4 V					
V <sub>OL</sub>	Low-level output voltage	V <sub>DD</sub> = 2 V to 6 V, I <sub>OL</sub> = 20 μA	0.2			V		
		V <sub>DD</sub> = 3.3 V, I <sub>OL</sub> = 2 mA	0.4					
		V <sub>DD</sub> = 6 V, I <sub>OL</sub> = 3 mA	0.4					
Power-up reset voltage (see Note 4)		V <sub>DD</sub> ≥ 1.1 V, I <sub>OL</sub> = 20 μA	0.4			V		
V <sub>IT-</sub>	Negative-going input threshold voltage (see Note 5)	V <sub>DD</sub> = 2 V to 6 V	SENSE3	1.2	1.25	1.29	V	
			SENSE1, SENSE2	VSENSE = 1.8 V	1.6	1.68		1.73
				VSENSE = 3.3 V	2.8	2.93		3.02
				VSENSE = 5 V	4.4	4.55		4.67
V <sub>hys</sub>	Hysteresis at VSENSE <sub>n</sub> input	V <sub>IT-</sub> = 1.25 V	2	10	30	mV		
		V <sub>IT-</sub> = 1.68 V	2	15	40			
		V <sub>IT-</sub> = 2.93 V	3	30	60			
		V <sub>IT-</sub> = 4.55 V	3	40	80			
I <sub>H</sub>	High-level input current	$\overline{\text{MR}}$	$\overline{\text{MR}} = 0.7 \times V_{\text{DD}}$ , V <sub>DD</sub> = 6 V	-130	-180	μA		
		SENSE1	VSENSE1 = V <sub>DD</sub> = 6 V	5	8			
		SENSE2	VSENSE2 = V <sub>DD</sub> = 6 V	6	9			
		SENSE3	VSENSE3 = V <sub>DD</sub>	-1	1			
I <sub>L</sub>	Low-level input current	$\overline{\text{MR}}$	$\overline{\text{MR}} = 0$ V, V <sub>DD</sub> = 6 V	-430	-600	μA		
		SENSE <sub>n</sub>	VSENSE1,2,3 = 0 V	-1	1			
I <sub>DD</sub>	Supply current				40	μA		
C <sub>i</sub>	Input capacitance	V <sub>I</sub> = 0 V to V <sub>DD</sub>		10		pF		

NOTES: 4. The lowest supply voltage at which  $\overline{\text{RESET}}$  becomes active.  $t_r$ , V<sub>DD</sub> ≥ 15 μs/V  
5. To ensure best stability of the threshold voltage, a bypass capacitor (ceramic 0.1 μF) should be placed close to the supply terminals.



# TPS3307-18-EP, TPS3307-33-EP TRIPLE PROCESSOR SUPERVISORS

SGLS140A – NOVEMBER 2002 – REVISED AUGUST 2005

timing requirements at  $V_{DD} = 2\text{ V to }6\text{ V}$ ,  $R_L = 1\text{ M}\Omega$ ,  $C_L = 50\text{ pF}$ ,  $T_A = 25^\circ\text{C}$

PARAMETER		TEST CONDITIONS	MIN	TYP	MAX	UNIT
$t_w$	Pulse width	$V_{SENSEnL} = V_{IT-} - 0.2\text{ V}$ , $V_{SENSEnH} = V_{IT+} + 0.2\text{ V}$	6			$\mu\text{s}$
		$V_{IH} = 0.7 \times V_{DD}$ , $V_{IL} = 0.3 \times V_{DD}$	100			ns

switching characteristics at  $V_{DD} = 2\text{ V to }6\text{ V}$ ,  $R_L = 1\text{ M}\Omega$ ,  $C_L = 50\text{ pF}$ ,  $T_A = 25^\circ\text{C}$

PARAMETER		TEST CONDITIONS	MIN	TYP	MAX	UNIT
$t_d$	Delay time	$V_I(\text{SENSEn}) \geq V_{IT+} + 0.2\text{ V}$ , $\overline{\text{MR}} \geq 0.7 \times V_{DD}$ , See timing diagram	140	200	280	ms
$t_{PHL}$	Propagation (delay) time, high-to-low level output	$\overline{\text{MR}}$ to $\overline{\text{RESET}}$		200	600	ns
$t_{PLH}$	Propagation (delay) time, low-to-high level output	$\overline{\text{MR}}$ to RESET				
$t_{PHL}$	Propagation (delay) time, high-to-low level output	SENSEn to $\overline{\text{RESET}}$				
$t_{PLH}$	Propagation (delay) time, low-to-high level output	SENSEn to RESET		1	5	$\mu\text{s}$



TYPICAL CHARACTERISTICS

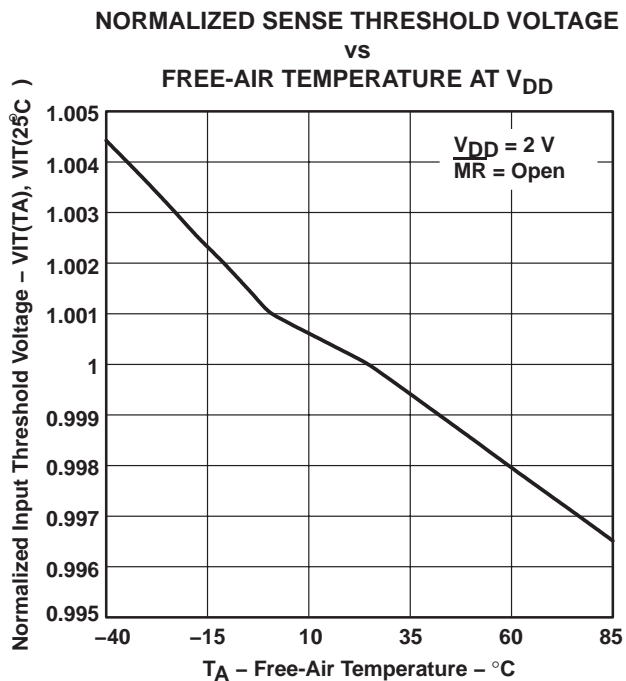

Figure 2

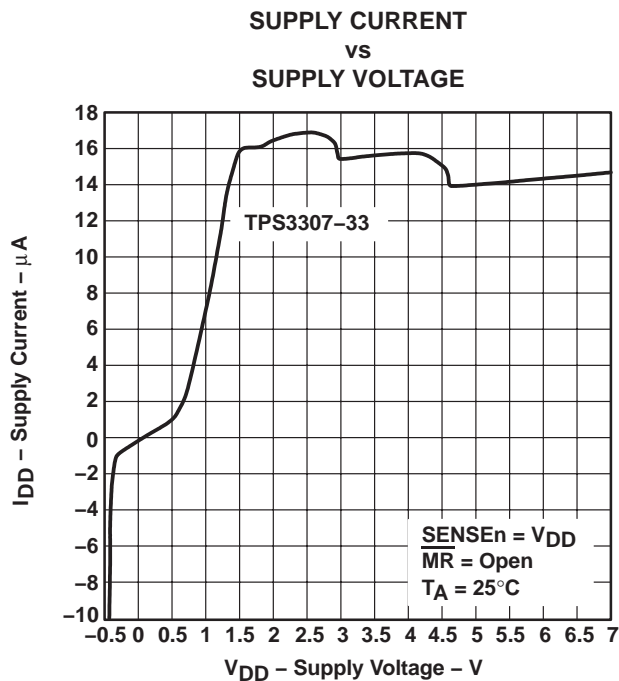

Figure 3

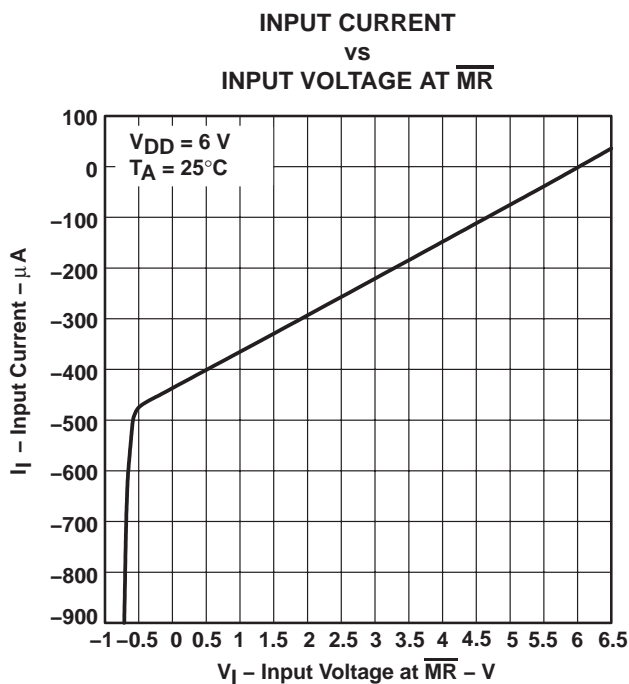

Figure 4

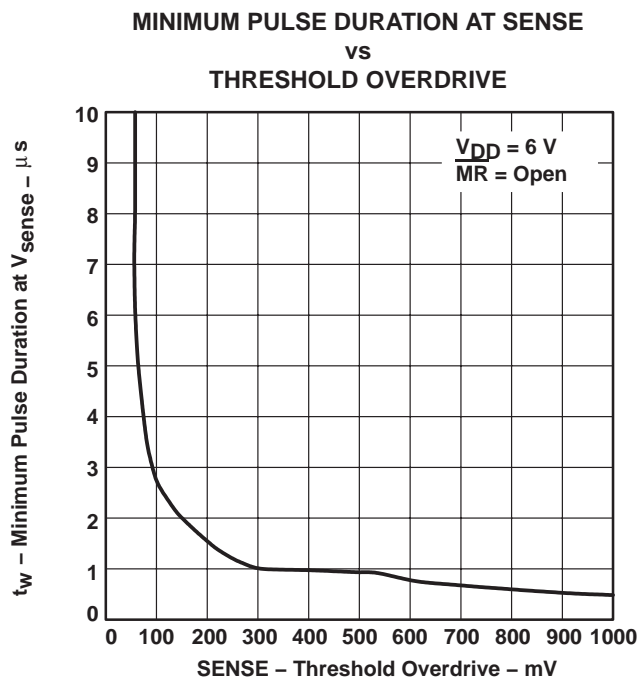
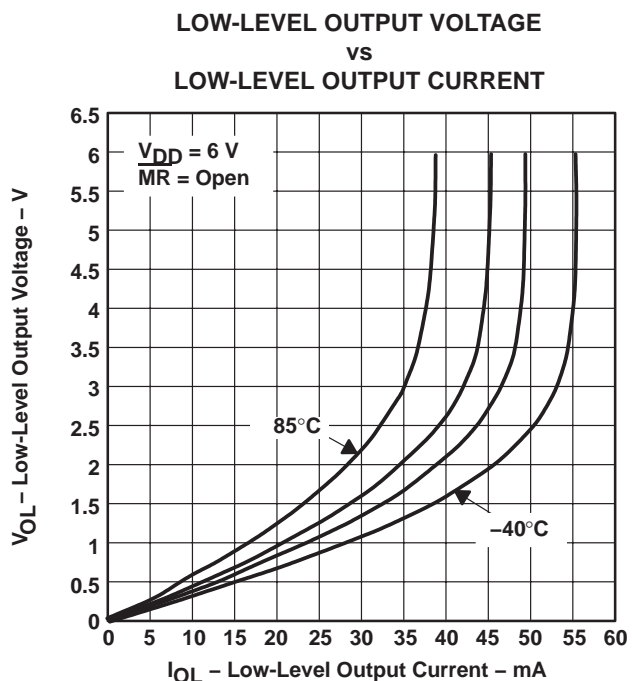
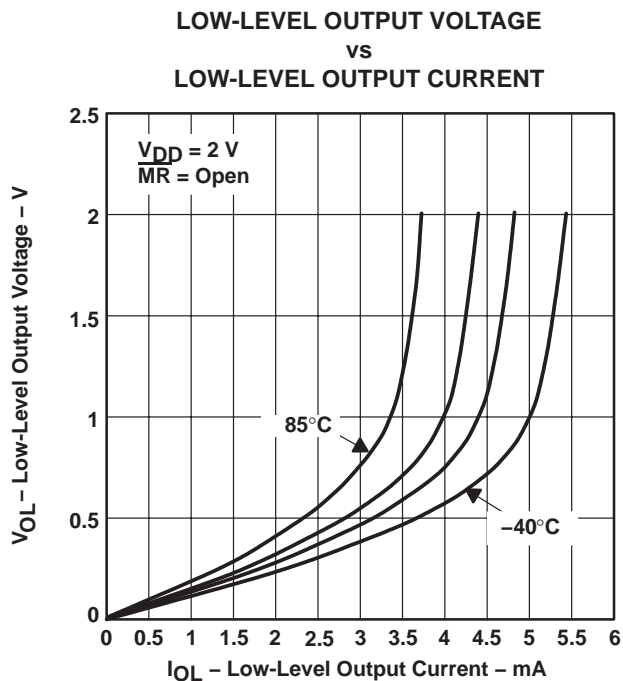
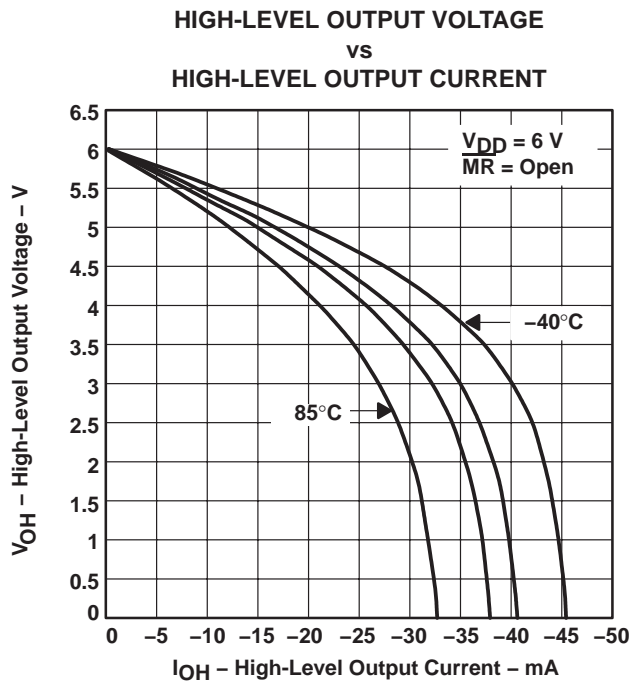
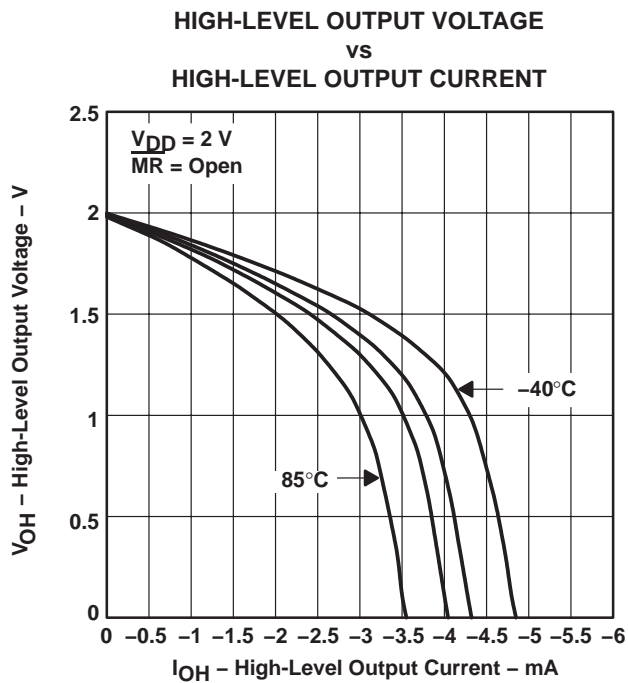

Figure 5

**TYPICAL CHARACTERISTICS**





## PACKAGING INFORMATION

Orderable Device	Status (1)	Package Type	Package Drawing	Pins	Package Qty	Eco Plan (2)	Lead/Ball Finish	MSL Peak Temp (3)	Op Temp (°C)	Top-Side Markings (4)	Samples
TPS3307-18MDREP	ACTIVE	SOIC	D	8	2500	Green (RoHS & no Sb/Br)	CU NIPDAU	Level-1-260C-UNLIM	-55 to 125	30718E	<a href="#">Samples</a>
TPS3307-18MDREPG4	ACTIVE	SOIC	D	8	2500	Green (RoHS & no Sb/Br)	CU NIPDAU	Level-1-260C-UNLIM	-55 to 125	30718E	<a href="#">Samples</a>
TPS3307-33MDGNREP	ACTIVE	MSOP- PowerPAD	DGN	8	2500	Green (RoHS & no Sb/Br)	CU NIPDAUAG	Level-1-260C-UNLIM	-55 to 125	BNP	<a href="#">Samples</a>
V62/03629-01XE	ACTIVE	SOIC	D	8	2500	Green (RoHS & no Sb/Br)	CU NIPDAU	Level-1-260C-UNLIM	-55 to 125	30718E	<a href="#">Samples</a>
V62/03629-02YE	ACTIVE	MSOP- PowerPAD	DGN	8	2500	Green (RoHS & no Sb/Br)	CU NIPDAUAG	Level-1-260C-UNLIM	-55 to 125	BNP	<a href="#">Samples</a>

(1) The marketing status values are defined as follows:

**ACTIVE:** Product device recommended for new designs.

**LIFEBUY:** TI has announced that the device will be discontinued, and a lifetime-buy period is in effect.

**NRND:** Not recommended for new designs. Device is in production to support existing customers, but TI does not recommend using this part in a new design.

**PREVIEW:** Device has been announced but is not in production. Samples may or may not be available.

**OBSOLETE:** TI has discontinued the production of the device.

(2) Eco Plan - The planned eco-friendly classification: Pb-Free (RoHS), Pb-Free (RoHS Exempt), or Green (RoHS & no Sb/Br) - please check <http://www.ti.com/productcontent> for the latest availability information and additional product content details.

**TBD:** The Pb-Free/Green conversion plan has not been defined.

**Pb-Free (RoHS):** TI's terms "Lead-Free" or "Pb-Free" mean semiconductor products that are compatible with the current RoHS requirements for all 6 substances, including the requirement that lead not exceed 0.1% by weight in homogeneous materials. Where designed to be soldered at high temperatures, TI Pb-Free products are suitable for use in specified lead-free processes.

**Pb-Free (RoHS Exempt):** This component has a RoHS exemption for either 1) lead-based flip-chip solder bumps used between the die and package, or 2) lead-based die adhesive used between the die and leadframe. The component is otherwise considered Pb-Free (RoHS compatible) as defined above.

**Green (RoHS & no Sb/Br):** TI defines "Green" to mean Pb-Free (RoHS compatible), and free of Bromine (Br) and Antimony (Sb) based flame retardants (Br or Sb do not exceed 0.1% by weight in homogeneous material)

(3) MSL, Peak Temp. -- The Moisture Sensitivity Level rating according to the JEDEC industry standard classifications, and peak solder temperature.

(4) Only one of markings shown within the brackets will appear on the physical device.

**Important Information and Disclaimer:** The information provided on this page represents TI's knowledge and belief as of the date that it is provided. TI bases its knowledge and belief on information provided by third parties, and makes no representation or warranty as to the accuracy of such information. Efforts are underway to better integrate information from third parties. TI has taken and continues to take reasonable steps to provide representative and accurate information but may not have conducted destructive testing or chemical analysis on incoming materials and chemicals. TI and TI suppliers consider certain information to be proprietary, and thus CAS numbers and other limited information may not be available for release.

In no event shall TI's liability arising out of such information exceed the total purchase price of the TI part(s) at issue in this document sold by TI to Customer on an annual basis.

**OTHER QUALIFIED VERSIONS OF TPS3307-18-EP, TPS3307-33-EP :**

- Catalog: [TPS3307-18](#), [TPS3307-33](#)
- Automotive: [TPS3307-18-Q1](#)
- Military: [TPS3307-18M](#)

NOTE: Qualified Version Definitions:

- Catalog - TI's standard catalog product
- Automotive - Q100 devices qualified for high-reliability automotive applications targeting zero defects
- Military - QML certified for Military and Defense Applications

**TAPE AND REEL INFORMATION**
**REEL DIMENSIONS**

**TAPE DIMENSIONS**

A0	Dimension designed to accommodate the component width
B0	Dimension designed to accommodate the component length
K0	Dimension designed to accommodate the component thickness
W	Overall width of the carrier tape
P1	Pitch between successive cavity centers

**TAPE AND REEL INFORMATION**

\*All dimensions are nominal

Device	Package Type	Package Drawing	Pins	SPQ	Reel Diameter (mm)	Reel Width W1 (mm)	A0 (mm)	B0 (mm)	K0 (mm)	P1 (mm)	W (mm)	Pin1 Quadrant
TPS3307-18MDREP	SOIC	D	8	2500	330.0	12.4	6.4	5.2	2.1	8.0	12.0	Q1
TPS3307-33MDGNREP	MSOP- Power PAD	DGN	8	2500	330.0	12.4	5.3	3.4	1.4	8.0	12.0	Q1

**TAPE AND REEL BOX DIMENSIONS**



\*All dimensions are nominal

Device	Package Type	Package Drawing	Pins	SPQ	Length (mm)	Width (mm)	Height (mm)
TPS3307-18MDREP	SOIC	D	8	2500	367.0	367.0	35.0
TPS3307-33MDGNREP	MSOP-PowerPAD	DGN	8	2500	358.0	335.0	35.0

DGN (S-PDSO-G8)

PowerPAD™ PLASTIC SMALL OUTLINE

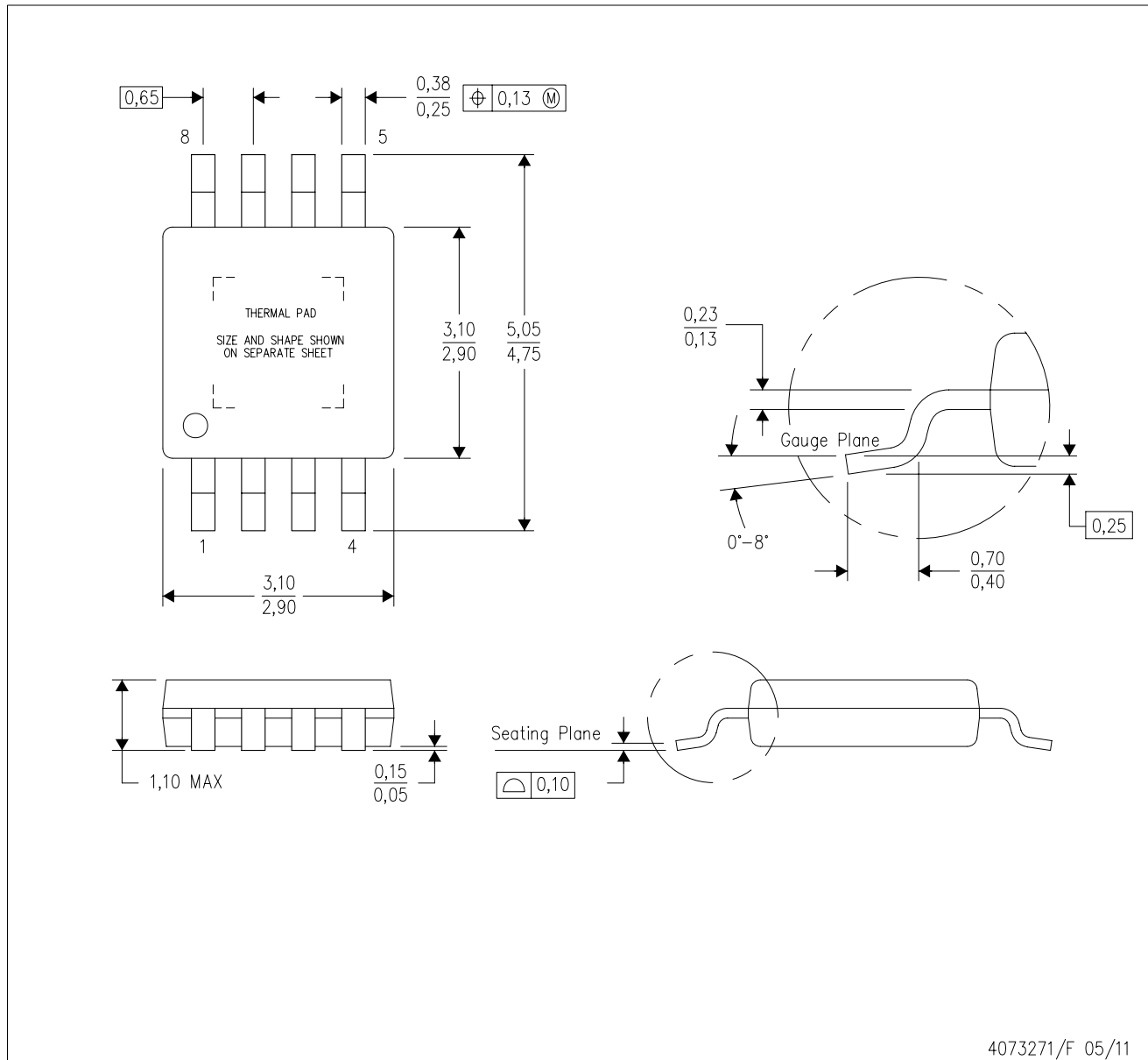

- NOTES:
- All linear dimensions are in millimeters.
  - This drawing is subject to change without notice.
  - Body dimensions do not include mold flash or protrusion.
  - This package is designed to be soldered to a thermal pad on the board. Refer to Technical Brief, PowerPad Thermally Enhanced Package, Texas Instruments Literature No. SLMA002 for information regarding recommended board layout. This document is available at [www.ti.com](http://www.ti.com) <<http://www.ti.com>>.
  - See the additional figure in the Product Data Sheet for details regarding the exposed thermal pad features and dimensions.
  - Falls within JEDEC MO-187 variation AA-T

PowerPAD is a trademark of Texas Instruments.

DGN (S-PDSO-G8)

PowerPAD™ PLASTIC SMALL OUTLINE

## THERMAL INFORMATION

This PowerPAD™ package incorporates an exposed thermal pad that is designed to be attached to a printed circuit board (PCB). The thermal pad must be soldered directly to the PCB. After soldering, the PCB can be used as a heatsink. In addition, through the use of thermal vias, the thermal pad can be attached directly to the appropriate copper plane shown in the electrical schematic for the device, or alternatively, can be attached to a special heatsink structure designed into the PCB. This design optimizes the heat transfer from the integrated circuit (IC).

For additional information on the PowerPAD package and how to take advantage of its heat dissipating abilities, refer to Technical Brief, PowerPAD Thermally Enhanced Package, Texas Instruments Literature No. SLMA002 and Application Brief, PowerPAD Made Easy, Texas Instruments Literature No. SLMA004. Both documents are available at [www.ti.com](http://www.ti.com).

The exposed thermal pad dimensions for this package are shown in the following illustration.

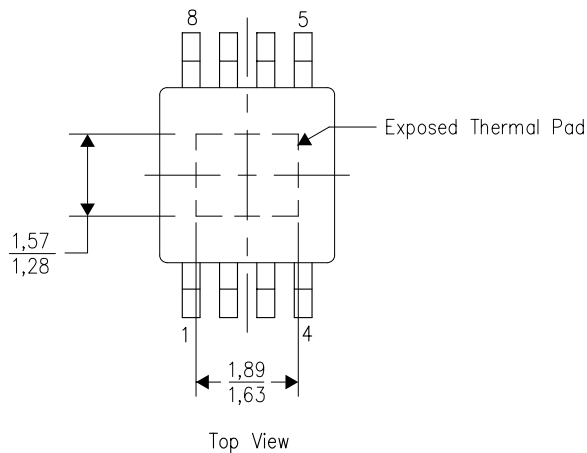

Exposed Thermal Pad Dimensions

4206323-2/1 12/11

NOTE: All linear dimensions are in millimeters

PowerPAD is a trademark of Texas Instruments

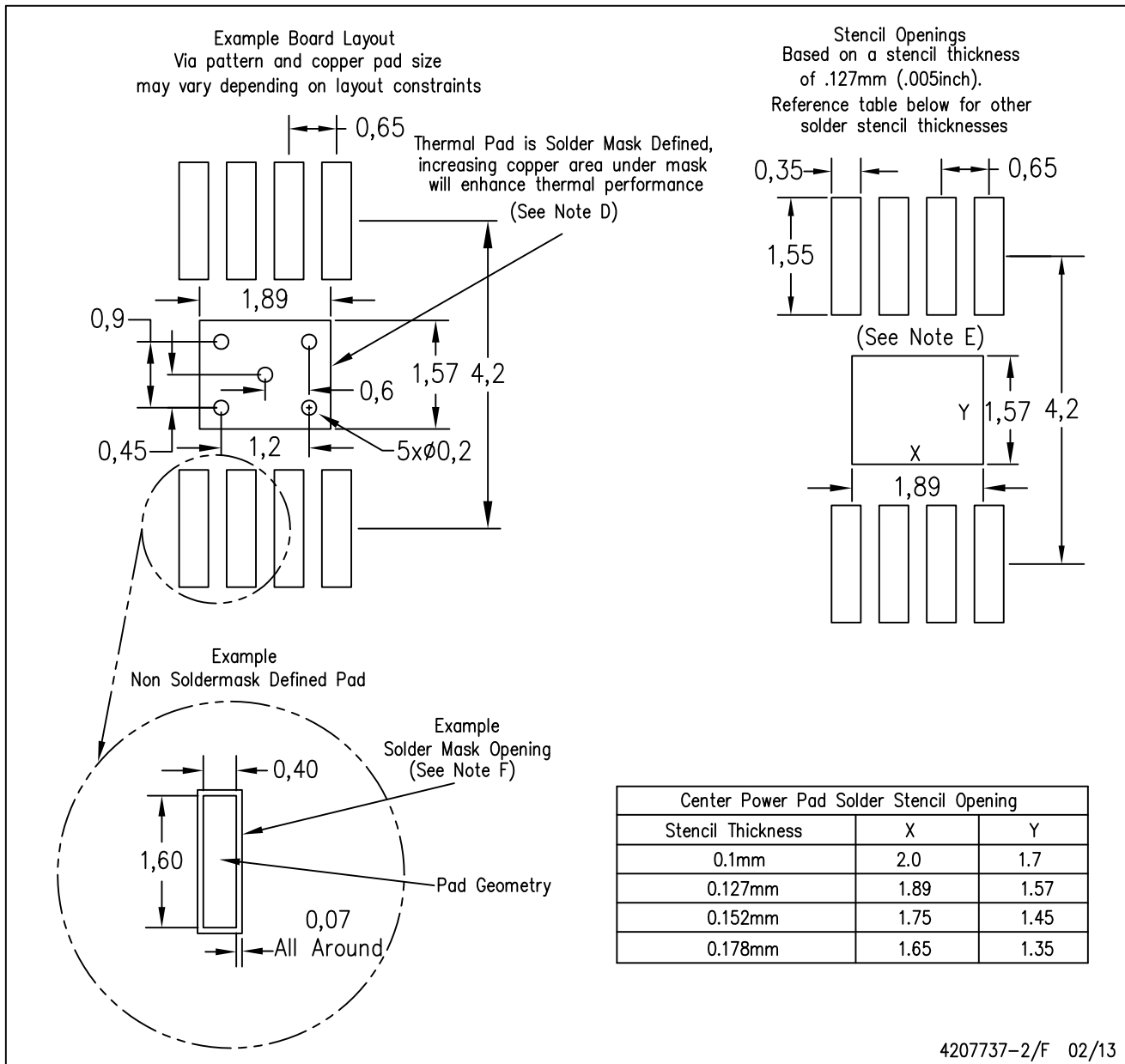

4207737-2/F 02/13

- NOTES:
- A. All linear dimensions are in millimeters.
  - B. This drawing is subject to change without notice.
  - C. Customers should place a note on the circuit board fabrication drawing not to alter the center solder mask defined pad.
  - D. This package is designed to be soldered to a thermal pad on the board. Refer to Technical Brief, PowerPad Thermally Enhanced Package, Texas Instruments Literature No. SLMA002, SLMA004, and also the Product Data Sheets for specific thermal information, via requirements, and recommended board layout. These documents are available at [www.ti.com](http://www.ti.com) <<http://www.ti.com>>.
  - E. Laser cutting apertures with trapezoidal walls and also rounding corners will offer better paste release. Customers should contact their board assembly site for stencil design recommendations. Example stencil design based on a 50% volumetric metal load solder paste. Refer to IPC-7525 for other stencil recommendations.
  - F. Customers should contact their board fabrication site for solder mask tolerances between and around signal pads.

PowerPAD is a trademark of Texas Instruments

D (R-PDSO-G8)

PLASTIC SMALL OUTLINE

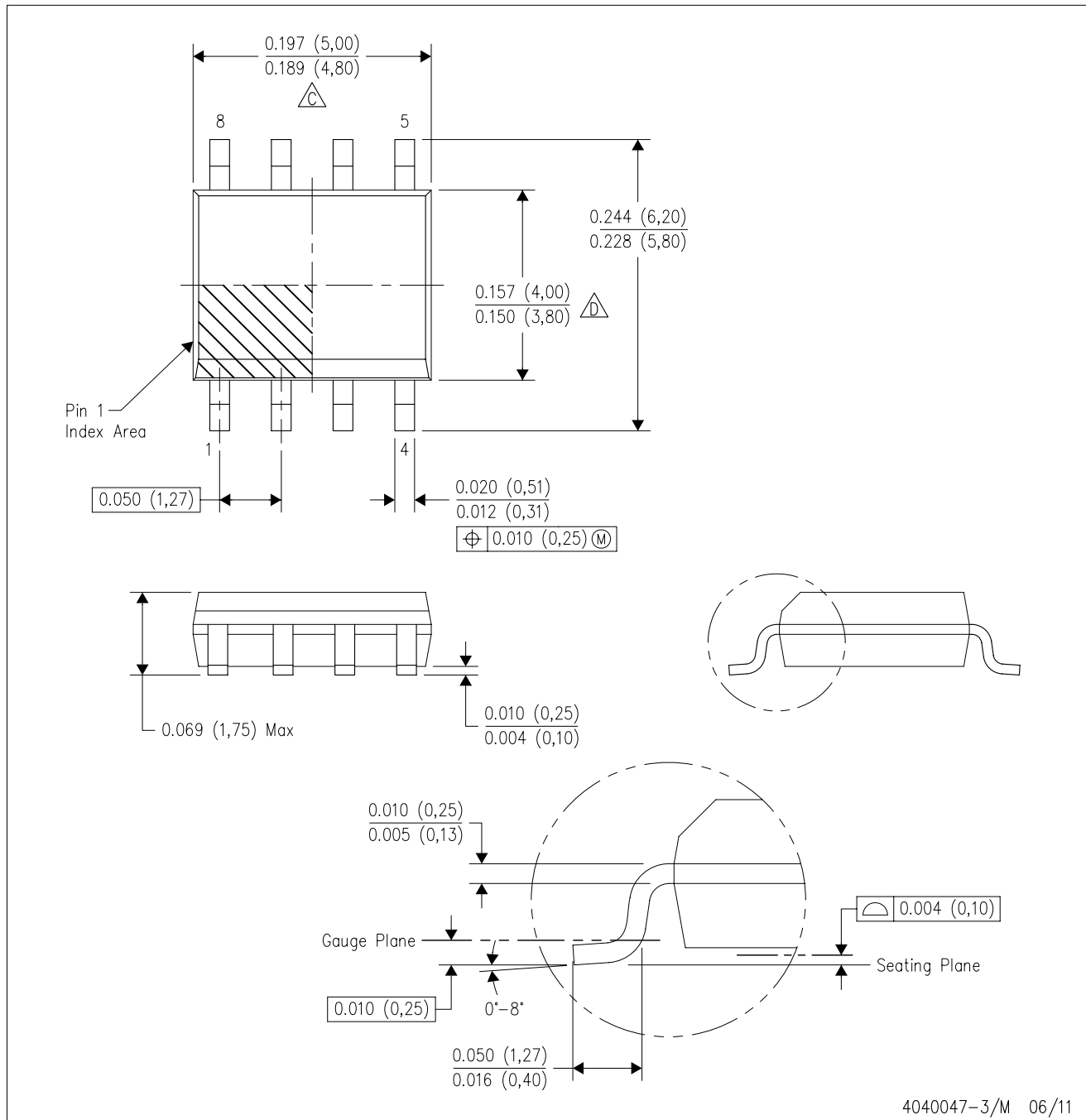

- NOTES:
- A. All linear dimensions are in inches (millimeters).
  - B. This drawing is subject to change without notice.
  - C. Body length does not include mold flash, protrusions, or gate burrs. Mold flash, protrusions, or gate burrs shall not exceed 0.006 (0,15) each side.
  - D. Body width does not include interlead flash. Interlead flash shall not exceed 0.017 (0,43) each side.
  - E. Reference JEDEC MS-012 variation AA.



D (R-PDSO-G8)

PLASTIC SMALL OUTLINE

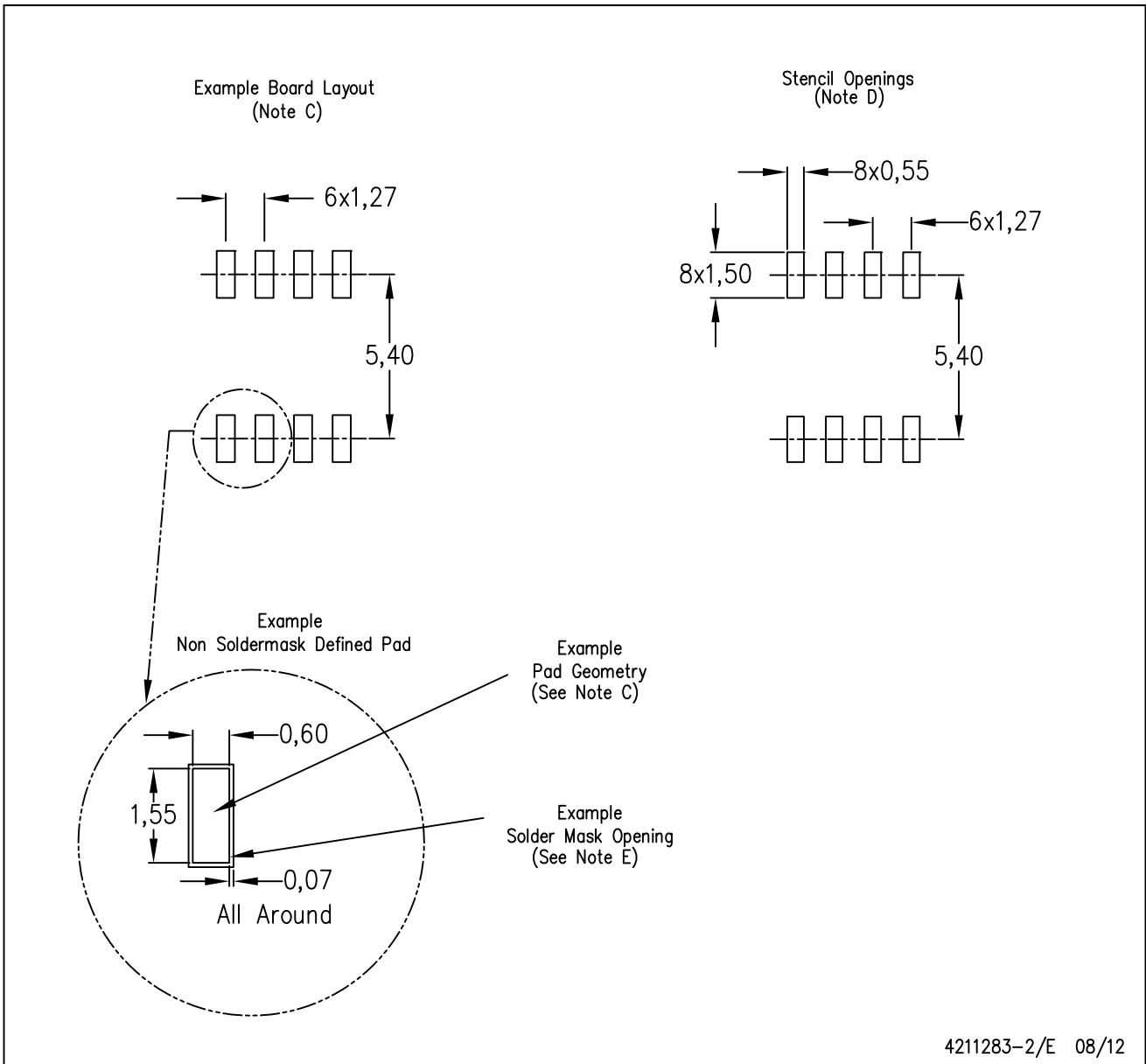

4211283-2/E 08/12

- NOTES:
- A. All linear dimensions are in millimeters.
  - B. This drawing is subject to change without notice.
  - C. Publication IPC-7351 is recommended for alternate designs.
  - D. Laser cutting apertures with trapezoidal walls and also rounding corners will offer better paste release. Customers should contact their board assembly site for stencil design recommendations. Refer to IPC-7525 for other stencil recommendations.
  - E. Customers should contact their board fabrication site for solder mask tolerances between and around signal pads.

## IMPORTANT NOTICE

Texas Instruments Incorporated and its subsidiaries (TI) reserve the right to make corrections, enhancements, improvements and other changes to its semiconductor products and services per JESD46, latest issue, and to discontinue any product or service per JESD48, latest issue. Buyers should obtain the latest relevant information before placing orders and should verify that such information is current and complete. All semiconductor products (also referred to herein as "components") are sold subject to TI's terms and conditions of sale supplied at the time of order acknowledgment.

TI warrants performance of its components to the specifications applicable at the time of sale, in accordance with the warranty in TI's terms and conditions of sale of semiconductor products. Testing and other quality control techniques are used to the extent TI deems necessary to support this warranty. Except where mandated by applicable law, testing of all parameters of each component is not necessarily performed.

TI assumes no liability for applications assistance or the design of Buyers' products. Buyers are responsible for their products and applications using TI components. To minimize the risks associated with Buyers' products and applications, Buyers should provide adequate design and operating safeguards.

TI does not warrant or represent that any license, either express or implied, is granted under any patent right, copyright, mask work right, or other intellectual property right relating to any combination, machine, or process in which TI components or services are used. Information published by TI regarding third-party products or services does not constitute a license to use such products or services or a warranty or endorsement thereof. Use of such information may require a license from a third party under the patents or other intellectual property of the third party, or a license from TI under the patents or other intellectual property of TI.

Reproduction of significant portions of TI information in TI data books or data sheets is permissible only if reproduction is without alteration and is accompanied by all associated warranties, conditions, limitations, and notices. TI is not responsible or liable for such altered documentation. Information of third parties may be subject to additional restrictions.

Resale of TI components or services with statements different from or beyond the parameters stated by TI for that component or service voids all express and any implied warranties for the associated TI component or service and is an unfair and deceptive business practice. TI is not responsible or liable for any such statements.

Buyer acknowledges and agrees that it is solely responsible for compliance with all legal, regulatory and safety-related requirements concerning its products, and any use of TI components in its applications, notwithstanding any applications-related information or support that may be provided by TI. Buyer represents and agrees that it has all the necessary expertise to create and implement safeguards which anticipate dangerous consequences of failures, monitor failures and their consequences, lessen the likelihood of failures that might cause harm and take appropriate remedial actions. Buyer will fully indemnify TI and its representatives against any damages arising out of the use of any TI components in safety-critical applications.

In some cases, TI components may be promoted specifically to facilitate safety-related applications. With such components, TI's goal is to help enable customers to design and create their own end-product solutions that meet applicable functional safety standards and requirements. Nonetheless, such components are subject to these terms.

No TI components are authorized for use in FDA Class III (or similar life-critical medical equipment) unless authorized officers of the parties have executed a special agreement specifically governing such use.

Only those TI components which TI has specifically designated as military grade or "enhanced plastic" are designed and intended for use in military/aerospace applications or environments. Buyer acknowledges and agrees that any military or aerospace use of TI components which have **not** been so designated is solely at the Buyer's risk, and that Buyer is solely responsible for compliance with all legal and regulatory requirements in connection with such use.

TI has specifically designated certain components as meeting ISO/TS16949 requirements, mainly for automotive use. In any case of use of non-designated products, TI will not be responsible for any failure to meet ISO/TS16949.

### Products

Audio	<a href="http://www.ti.com/audio">www.ti.com/audio</a>
Amplifiers	<a href="http://amplifier.ti.com">amplifier.ti.com</a>
Data Converters	<a href="http://dataconverter.ti.com">dataconverter.ti.com</a>
DLP® Products	<a href="http://www.dlp.com">www.dlp.com</a>
DSP	<a href="http://dsp.ti.com">dsp.ti.com</a>
Clocks and Timers	<a href="http://www.ti.com/clocks">www.ti.com/clocks</a>
Interface	<a href="http://interface.ti.com">interface.ti.com</a>
Logic	<a href="http://logic.ti.com">logic.ti.com</a>
Power Mgmt	<a href="http://power.ti.com">power.ti.com</a>
Microcontrollers	<a href="http://microcontroller.ti.com">microcontroller.ti.com</a>
RFID	<a href="http://www.ti-rfid.com">www.ti-rfid.com</a>
OMAP Applications Processors	<a href="http://www.ti.com/omap">www.ti.com/omap</a>
Wireless Connectivity	<a href="http://www.ti.com/wirelessconnectivity">www.ti.com/wirelessconnectivity</a>

### Applications

Automotive and Transportation	<a href="http://www.ti.com/automotive">www.ti.com/automotive</a>
Communications and Telecom	<a href="http://www.ti.com/communications">www.ti.com/communications</a>
Computers and Peripherals	<a href="http://www.ti.com/computers">www.ti.com/computers</a>
Consumer Electronics	<a href="http://www.ti.com/consumer-apps">www.ti.com/consumer-apps</a>
Energy and Lighting	<a href="http://www.ti.com/energy">www.ti.com/energy</a>
Industrial	<a href="http://www.ti.com/industrial">www.ti.com/industrial</a>
Medical	<a href="http://www.ti.com/medical">www.ti.com/medical</a>
Security	<a href="http://www.ti.com/security">www.ti.com/security</a>
Space, Avionics and Defense	<a href="http://www.ti.com/space-avionics-defense">www.ti.com/space-avionics-defense</a>
Video and Imaging	<a href="http://www.ti.com/video">www.ti.com/video</a>

### TI E2E Community

[e2e.ti.com](http://e2e.ti.com)



Компания «ЭлектроПласт» предлагает заключение долгосрочных отношений при поставках импортных электронных компонентов на взаимовыгодных условиях!

Наши преимущества:

- Оперативные поставки широкого спектра электронных компонентов отечественного и импортного производства напрямую от производителей и с крупнейших мировых складов;
- Поставка более 17-ти миллионов наименований электронных компонентов;
- Поставка сложных, дефицитных, либо снятых с производства позиций;
- Оперативные сроки поставки под заказ (от 5 рабочих дней);
- Экспресс доставка в любую точку России;
- Техническая поддержка проекта, помощь в подборе аналогов, поставка прототипов;
- Система менеджмента качества сертифицирована по Международному стандарту ISO 9001;
- Лицензия ФСБ на осуществление работ с использованием сведений, составляющих государственную тайну;
- Поставка специализированных компонентов (Xilinx, Altera, Analog Devices, Intersil, Interpoint, Microsemi, Aeroflex, Peregrine, Syfer, Eurofarad, Texas Instrument, Miteq, Cobham, E2V, MA-COM, Hittite, Mini-Circuits, General Dynamics и др.);

Помимо этого, одним из направлений компании «ЭлектроПласт» является направление «Источники питания». Мы предлагаем Вам помощь Конструкторского отдела:

- Подбор оптимального решения, техническое обоснование при выборе компонента;
- Подбор аналогов;
- Консультации по применению компонента;
- Поставка образцов и прототипов;
- Техническая поддержка проекта;
- Защита от снятия компонента с производства.



#### Как с нами связаться

**Телефон:** 8 (812) 309 58 32 (многоканальный)

**Факс:** 8 (812) 320-02-42

**Электронная почта:** [org@eplast1.ru](mailto:org@eplast1.ru)

**Адрес:** 198099, г. Санкт-Петербург, ул. Калинина, дом 2, корпус 4, литера А.