

## Description



- A GPS disciplined OCXO incorporating sync to a 1pps input and 1pps output with 1.5µs holdover stability achieved by using an adaptive algorithm. Current internal parameters of the algorithm are available to the user via Tx and Rx commands.
- Model IQCM-200
- Model Issue number 1
- Application Information (Reference Drawing):  
Connect the 1PPS output of your GPS system to the IQCM-200. A MCU can be used to monitor the working state of the IQCM-200.
- Working States (Reference Drawing):  
Run1: Fast track. Adjust the OCXO 10MHz output frequency quickly to track the 1PPS to 10MHz with 1PPS reference.  
Run2: Slow track. Adjust the OCXO 10MHz output frequency slowly when phase error is in the defined range.  
Holdover: No 1PPS input present; an algorithm enables adaptive modelling of the frequency stability of an OCXO with reference to the GPS timing signal.  
Free Run: Clock module powered up with no 1PPS input.
- Note1: The IQCM-200 should be left powered and running for 7 days minimum before operation to allow for the OCXO's internal drift to stabilise.  
Note2: The adaptive module algorithm can be built after two days operation with good GPS signal, however this data will be lost at power down.  
Note3: When State input (Pin 8) is set low the IQCM-200 will operate in Holdover mode regardless of the 1PPS signal condition.
- Output Data Word Example:  
\$PDP,00,0,F,Q,-3095,32768.0000,32768.0000,000,000,00000.  
0000,00000.0000,00000.0000,00000.0000,3-23,+000.0000,-00  
00,www.iqdfp.com,1,1,2011-05-16\*55

(See table for full description)



## Outline (mm)

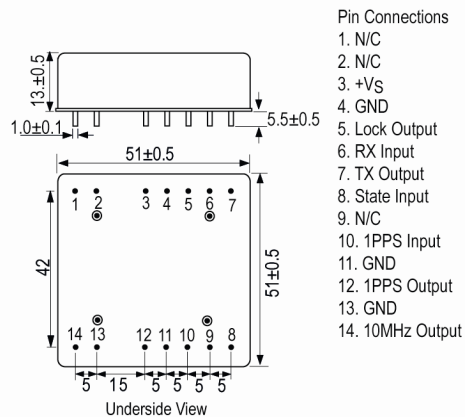

## Frequency Parameters

- Frequency 10.0MHz
  - Operating Temperature Range -10.00 to 70.00°C
  - 10MHz RF Output Details, Pin 14:  
HCMOS Compatible, 15pF load  
(Sinewave 50Ω option available)  
VoH: 2.7V min  
VoL: 0.4V max  
Rise and Fall time: 8ns max  
Duty Cycle: 45/55% max  
Accuracy (24-hour averaging when locked to 1PPS): ±1E-12  
Short Term Stability (tested after power for 1hr ref to 25°C, 1s, using PN9000 test equipment): 2E-11 max  
Ageing (Vs and temperature constant, reference to T=25°C, Vs = 5.0V and after 30 days operation): ±0.2ppb per day, ±10ppb per year
  - 24Hrs Holdover Capability  
Reference 7 days powered on, 2 days GPS lock  
Temperature varied <1°C/min within operating temperature range
- Total temperature change    Holdover capability  
ΔT<±2°C                            ±1.5µs

Note: Other options available on request

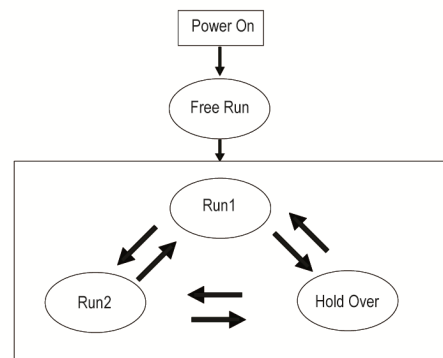

## Sales Office Contact Details:

UK: +44 (0)1460 270200  
Germany: 0800 1808 443

France: 0800 901 383  
USA: +1.760.318.2824

Email: [info@iqdfrequencyproducts.com](mailto:info@iqdfrequencyproducts.com)  
Web: [www.iqdfrequencyproducts.com](http://www.iqdfrequencyproducts.com)

**Electrical Parameters**

- Supply Voltage 5.0V ±5%
- 1PPS Reference Input, Pin 10 (15pF test condition):  
Waveform: HCMOS  
ViH: 2.7V min  
ViL: 0.4V max  
Pulse Width: 10us min
- State Input, Pin 8 (<5mA load):  
Lock: 2.7V min  
Unlock: 0.5V max
- Power Supply Details, Pin 3:  
Supply Voltage: 5.0V ±5%  
Current Consumption: 1.4A during warm up, 600mA steady state @25°C  
AC Ripple: 50mV pk-pk max, 10Hz to 1MHz

**Output Details**

- Output Compatability HCMOS
- 1PPS Reference Output, Pin 12 (50Ω test condition):  
Waveform: HCMOS  
VoH: 2.7V min  
VoL: 0.4V max  
Pulse Width: 10μs min
- Lock Status Indicator, Pin 5:  
Module Locked: 2.7V min  
Module Holdover: 0.4V max  
Module Locked means Working State is = Run2
- Serial interface (pin6 and pin7)  
UART  
VoL and ViL: 0.4V max  
VoH and ViH: 2.7V min  
Baud rate: 9600  
Bits: 8  
Paraty: N  
Stop Bit: 1

**Noise Parameters**

- Phase Noise on 10MHz RF output signal (dBm/Hz)

Offset	Typical	Max
10Hz	-118	-113
100Hz	-138	-133
1kHz	-148	-143
10kHz	-150	-145
100kHz	-150	-145
1MHz	-150	-150

**Environmental Parameters**

- Operating Temperature Range: -10 to 70°C
- Storage Conditions:  
Temperature: -55 to 105°C  
Humidity: 30 to 80%
- Shock: IEC68-2-27 Test Ea, severity 50A, 50G 11ms half sinewave, 3 times in three mutually perpendicular axes
- Vibration: IEC 68-2-06 Test Fc, 10G, 0.75mm acceleration, 10Hz to 500Hz, 3 times in three mutually perpendicular axes

**Manufacturing Details**

- ESD Level:  
ANSI/ESDA/JEDEC JS-001-2010; HBM Class 2; 2kV to 4kV  
ANSI/ESDA/JEDEC JS-001-2010; Machine Model Class B  
200V to 400V

**Sales Office Contact Details:**

UK: +44 (0)1460 270200  
Germany: 0800 1808 443

France: 0800 901 383  
USA: +1.760.318.2824

Email: [info@iqdfrequencyproducts.com](mailto:info@iqdfrequencyproducts.com)  
Web: [www.iqdfrequencyproducts.com](http://www.iqdfrequencyproducts.com)

## Compliance

- RoHS Status (2011/65/EU)      Compliant
- REACH Status                      Compliant
- MSL Rating (JDEC-STD-033):    Not Applicable

## Packaging Details

- Pack Style: Bulk      Loose in bulk pack  
Pack Size: 1
- *Alternative packing option available*

## Technical Notes

- *Holdover stability 1.5µs in 24hrs ref ±2°C*

## Functional Block Diagram

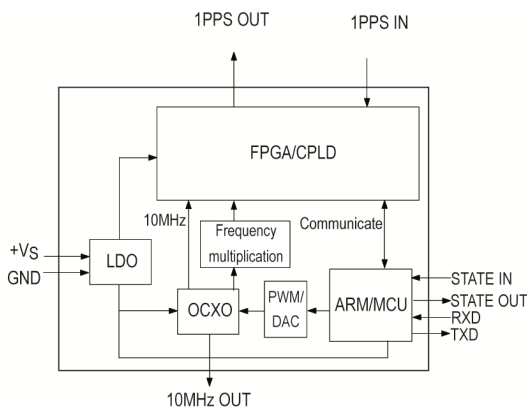

## Application Information

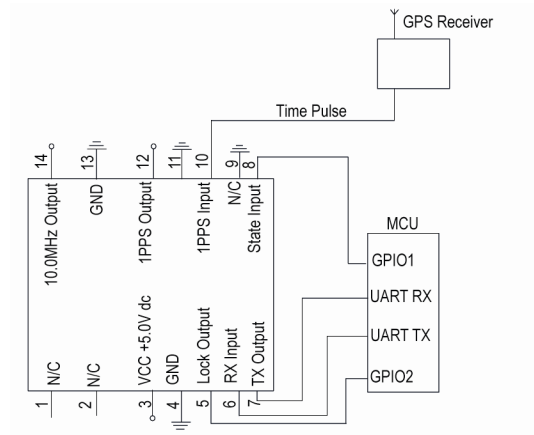

## Sales Office Contact Details:

UK: +44 (0)1460 270200  
Germany: 0800 1808 443

France: 0800 901 383  
USA: +1.760.318.2824

Email: [info@iqdfrequencyproducts.com](mailto:info@iqdfrequencyproducts.com)  
Web: [www.iqdfrequencyproducts.com](http://www.iqdfrequencyproducts.com)

**Output Data Word (Format Key: c=Character, d=Numerical Digit, s=Sign)**

Field NO.	Name	Format	Description	Length	
0	\$PDP	\$ccc	Message ID, Protocol Header	4	
1	No	dd	Message No	2	
2	TxRxFlag	d	Transmit and Receive Flag (0=upper computer transmit, 1=upper computer receive)	1	
3	CStatus	c	Current Status (F=warm up, L=lock, H=holdover)	1	
4	TrackStatus	d	Track status (Q= fast track, S = slow track)	1	
5	cPHDiff	sdddd	Current phase difference, 1 unit = 6.25ns	5	
6	cPWM1	dddd.dddd	Current PWM1 (Voltage control value1)	10	
7	cPWM2	dddd.dddd	Current PWM2 (Voltage Controlled Value 2), not used, default value =32769.000000	10	
8	SYNCNT	ddd	The synchronous times	3	
9	HCNT	ddd	Power on hours count	3	
10	HPAVG	dddd.dddd	The average of the PWM in the last half hour	10	
11	VCH1	dddd.dddd	Voltage Controlled compensation value every half hour	10	
12	HPMOD	dddd.dddd	The Module PWM Value	10	
13	VCM10	dddd.dddd	Voltage controlled compensation value every 10mins	10	
14	POS	d-dd	The position of the product. (Layer-No), just for the inner test.	4	
15	inT	sdddd.ddd	NA	9	
16	TcPHDiff	sdddd	The product current phase difference	5	
17	Website		www.IQDFP.com	13	
18	Version	d.d	version	3	
19	Date	ddd-dd-dd	Date	10	
20		dd	55	2	
21	END		<CR><LF>	2	

**Sales Office Contact Details:**

UK: +44 (0)1460 270200  
Germany: 0800 1808 443

France: 0800 901 383  
USA: +1.760.318.2824

Email: [info@iqdfrequencyproducts.com](mailto:info@iqdfrequencyproducts.com)  
Web: [www.iqdfrequencyproducts.com](http://www.iqdfrequencyproducts.com)



Компания «ЭлектроПласт» предлагает заключение долгосрочных отношений при поставках импортных электронных компонентов на взаимовыгодных условиях!

Наши преимущества:

- Оперативные поставки широкого спектра электронных компонентов отечественного и импортного производства напрямую от производителей и с крупнейших мировых складов;
- Поставка более 17-ти миллионов наименований электронных компонентов;
- Поставка сложных, дефицитных, либо снятых с производства позиций;
- Оперативные сроки поставки под заказ (от 5 рабочих дней);
- Экспресс доставка в любую точку России;
- Техническая поддержка проекта, помощь в подборе аналогов, поставка прототипов;
- Система менеджмента качества сертифицирована по Международному стандарту ISO 9001;
- Лицензия ФСБ на осуществление работ с использованием сведений, составляющих государственную тайну;
- Поставка специализированных компонентов (Xilinx, Altera, Analog Devices, Intersil, Interpoint, Microsemi, Aeroflex, Peregrine, Syfer, Eurofarad, Texas Instrument, Miteq, Cobham, E2V, MA-COM, Hittite, Mini-Circuits, General Dynamics и др.);

Помимо этого, одним из направлений компании «ЭлектроПласт» является направление «Источники питания». Мы предлагаем Вам помощь Конструкторского отдела:

- Подбор оптимального решения, техническое обоснование при выборе компонента;
- Подбор аналогов;
- Консультации по применению компонента;
- Поставка образцов и прототипов;
- Техническая поддержка проекта;
- Защита от снятия компонента с производства.



#### Как с нами связаться

**Телефон:** 8 (812) 309 58 32 (многоканальный)

**Факс:** 8 (812) 320-02-42

**Электронная почта:** [org@eplast1.ru](mailto:org@eplast1.ru)

**Адрес:** 198099, г. Санкт-Петербург, ул. Калинина, дом 2, корпус 4, литера А.